



## **Section 1. Main points**

1. Yak-52. General Information.
2. Aircraft Main Technical Data.
3. Engine Main Technical Data.
4. Aircraft Performance.
5. Operation limitations.
6. Some Practical Aerodynamic Data of Yak-52.
7. Manoeuvrability of Yak-52.
8. Emergency Recommendations
9. Data and Recommendations for Forced Unpowered Landing
10. Ground Safety.
11. Flight Safety.

## **Section 2. Flight Preparation**

1. Visual Inspection of the Aircraft.
2. Pilot's Actions before Entering the Aircraft.
3. Pilot's Actions after Entering the Aircraft.
4. Engine Starting. Warming up and Testing on the Ground.
5. Attitude Indicator. Switching on and Checking.
6. Radio Station Switching on and Checking.
7. Rear Cockpit Preparation for Solo Flight.

## **Section 3. Pattern Flight**

1. Preparation for taxiing
2. Taxiing
3. Take off run
4. Lift-off
5. Initial climb
6. Climb
7. Crosswind take off and climb
8. Typical mistakes in the course of the take off
9. Upwind leg
10. First turn
11. Crosswind
12. Second turn
14. Third turn
15. Base leg
16. Fourth turn
17. Final Approach
18. Touchdown
19. Afterlanding Roll
20. Taxiing after landing
21. Engine shutdown
22. Climbing flight
23. Straight and level flight

## SECTION1. MAIN POINTS

### 1.YAK-52. GENERAL INFORMATION

Yak-52 with M 14P 360 hp engine installed is a cantilever low-wing monoplane with a nose wheel retractable landing gear. The airplane's purpose is flight training for take off/landing, high performance manoeuvre flight with G limits from +7 to-5, navigation and instrumental flights in day time. Yak-52 allows to perform all figures from Aresti catalogue, including inverted flight.

The equipping of the plane with a radio-station, intercommunication system, navigation-piloting apparatus, of the split flaps and of retractable undercarriage offers a pilot-student the possibility to master the skills necessary to the use of the apparatus the modern airplanes are equipped with.

- 1) Propeller V-530 TA-D35
- 2) Engine M-14P
- 3) Retractable landing gear
- 4) Oil tank
- 5) Fuel tanks
- 6) Battery
- 7) Radio
- 8) Front cockpit
- 9) Rear (instructor's) cockpit

Yak-52 is designed to operate from ground airfields with ground toughness over 3.5 kg/cm<sup>2</sup>, and from snow airfields with skis installed.

#### GENERAL DATA

Wing area, m <sup>2</sup>	15.00
Dry weight, kg	1000
Take-off weight, kg	1290
Wing loading, kg/m <sup>2</sup>	86
Power loading, kg/hp	3.58
Never exceed air speed, knots (km/h)	230 (420)
Power plant thrust at zero air speed, kg	550
Rate of climb at sea level, m/s	10
Take off run, m	170
Landing run, m	200
Range, km	500

## FRONT COCKPIT

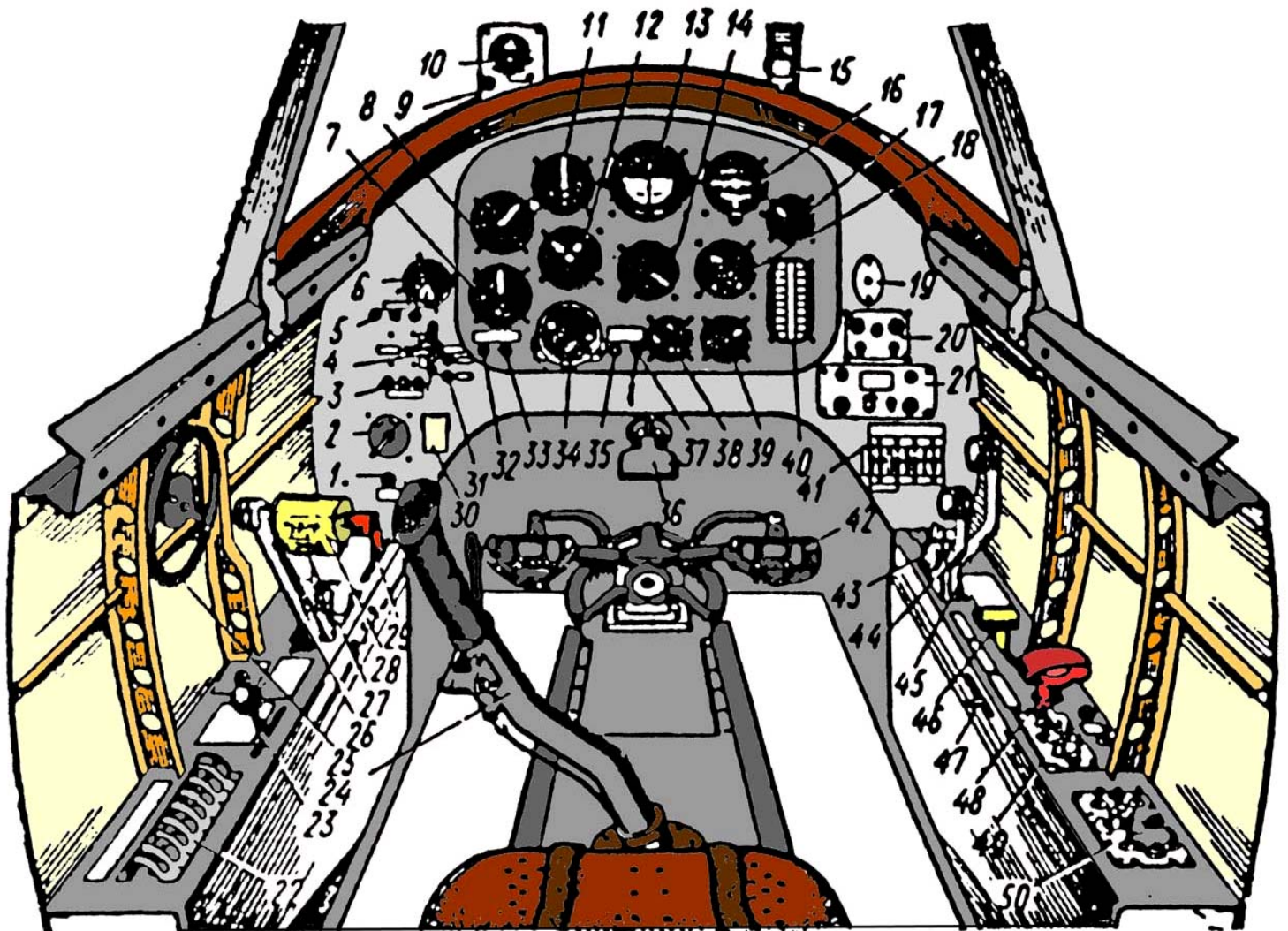

1. Lamps check button; 2. Magneto switch; 3. "Landing gear extended" warning lamps (green); 4. Landing gear control; 5. "Landing gear retracted" warning lamps (red); 6. Main and emergency air system pressure gauge; 7. Manifold pressure gauge; 8. Tachometer; 9. Maximum "G" indicator lamp (red); 10. Accelerometer ("G"-meter); 11. Speed indicator; 12. Altimeter; 13. Attitude indicator; 14. Heading indicator; 15. Magnetic compass; 16. Turn and slip indicator; 17. Voltammeter; 18. Three arrow indicator (Oil and fuel pressure, oil temperature); 19. Primer; 20. Intercom system control panel; 21. Radio station control panel; 22. "Radio" | "Intercom" | "Attitude indicator" | "Landing gear Warning" | "Direct to alternate current transformer" | "Radio-compass" | "Gyro-magnetic compass" switches; 23. Landing flaps control lever; 24. Control Stick; 25. Elevator Trim Tab Control wheel; 26. Propeller Pitch Control Lever; 27. Friction Lever; 28. Throttle Lever With Radio/Intercom PTT (press to talk) Buttons; 29. Fire Cut-off Valve; 30. Engine Start Button; 31. "Landing flaps extended/retracted" Warning Lights (green/yellow); 32. "Generator failure" signal lamp (red); 33. "Shaving in oil" signal lamp (yellow); 34. Clock; 35. "Pitot tube heater on" signal lamp (green); 36. Cockpit ventilation nozzle; 37. "Do not use gyro-magnetic compass" signal lamp (yellow); 38. Inlet mixture temperature gauge; 39. Cylinder head temperature gauge; 40. Fuel quantity indicator; 41. "Battery" | "Generator" | "Ignition" | "Pitot tube heater" switches; 42. Rudder pedals; 43. Catch; 44. Oil-cooling system valve control jack; 45. Engine cowl flaps; 46. Air-fuel mixture heater valve control; 47. Ventilation control; 48. Landing gear emergency extension cock; 49. Radio-compass panel; 50. Gyro-magnetic compass system panel.

## 2. THE MAIN AIRCRAFT TECHNICAL DATA

### 2.1. GEOMETRICAL DATA WEIGHT DATA

Overall length, m	7.676
Wingspan, m	9.500
Height, m	2.700
Wing area, m <sup>2</sup>	15.00
Wing lateral V, degrees	2.0
Wing incidence angle, degrees	2.0

Dry weight, kg	1000+1
Fuel weight, kg	90
Oil weight, kg	10
Parachute weight, kg	15
Take off weight, kg	1290

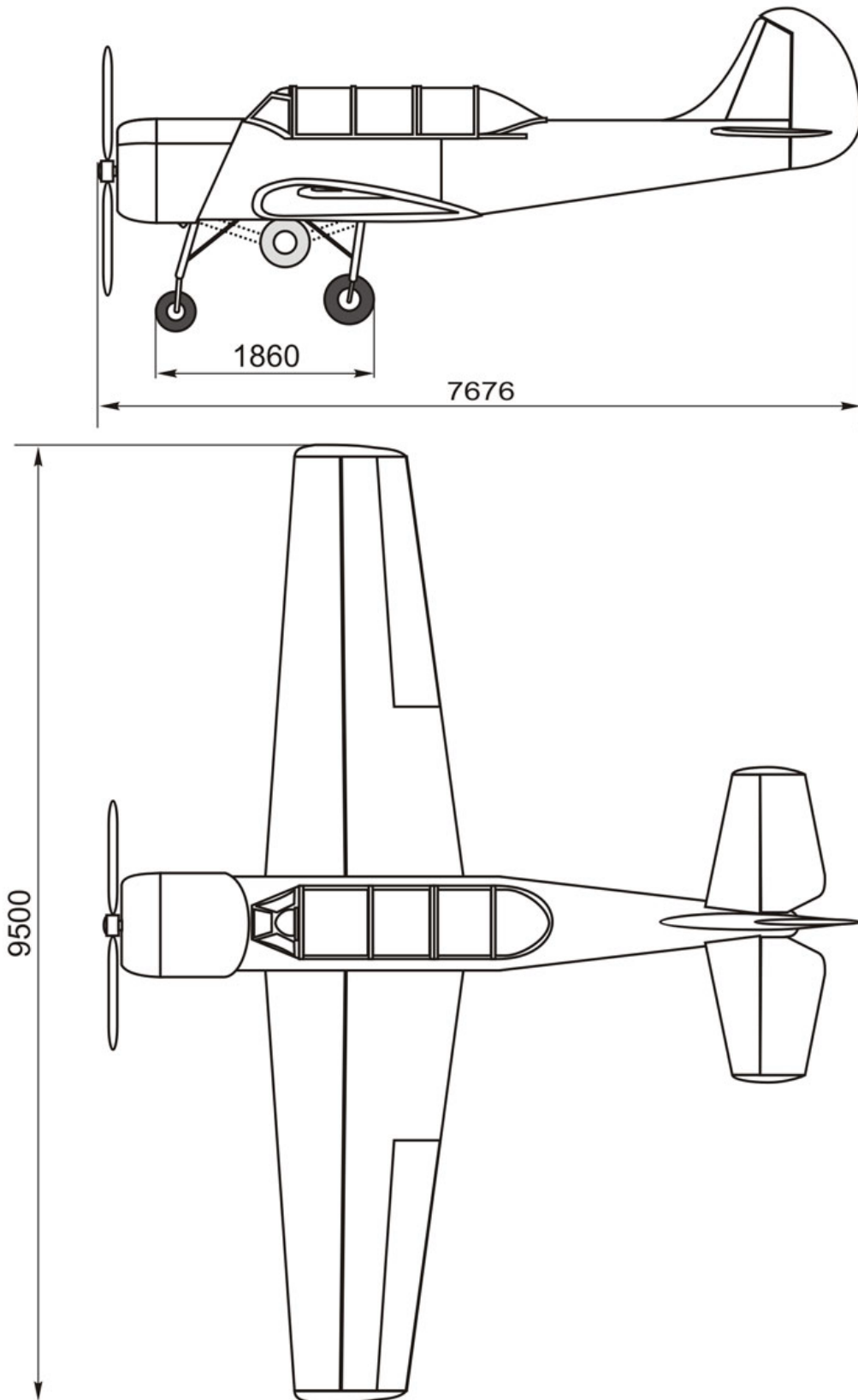

### 3. ENGINE MAIN TECHNICAL DATA

#### 3.1 MAIN FEATURES

Cooling system	air
Type and Number of Cylinders	radial, one row, 9
Engine Gear Box Ratio	0.658
Supercharger drive gear ratio	8.16
Altitude tolerance	sea-level engine
Mixture compression ratio	10.6
Fuel type	91/115
Octane Number, not less	78
Carburettor type	pressure
Oil grade	MK-22 or MS-20
Dry weight, kg	214

#### 3.3 POWER SETTINGS

Power setting	Output, hp	RPM	Fuel consumption grams/hp·hour	Manifold pressure, mms Mercury
take off	360-2%	2900±1% (99±1%)	285-315*	125±15 (excessive)
nominal 1	290-2%	2400±1% (82±1%)	280-310	95±15 (excessive)
nominal 2	240-2%	2050±1% (70±1%)	265-300	75±15 (excessive)
cruise 1	180-2%	1860±1% (64±%)	210-230	735±15 (absolute)
cruise 2	144-2%	1730±1% (59±%)	215-235	670±15 (absolute)
idle		not more than 700 (26%)	-	-

#### 4. AIRCRAFT PERFORMANCE

Maximum level air speed (H=500 m), kmph	300
Range (V=190 kmph, take off weight 1290 kg, H=500 m, flight endurance 2hrs 45 min, 10% fuel remainder)	510
Stall speed with engine idling, kmph:	
level flight	110
inverted flight	140
with landing flaps extended	100
Take off run, m	180
Landing roll, m	300

## 5. OPERATION LIMITATIONS

### 5.1 AIRCRAFT

Never exceed air speed, kmph	420
Maximum Aerobatics Speed, kmph	360
G limits	+ 7/-5
Maximum air speed with landing gear extended, kmph	200
Minimum level flight speed, kmph:	130
inverted flight	170
Maximum permanent inverted flight time, min	2

Maintain level flight at least 3 minutes after 2 min of inverted flight to cool on oil.

Maximum flight altitude without oxygen equipment 4000m.

Minimum fuel quantity for aerobatic flight 20l.

### 5.2 ENGINE

#### Maximum permanent operation time

1) at	take off power setting	5 min
2) at	maximum rpm	1 min
3) at	all other power settings	without limitation
4) in	inverted flight	2 min
	maximum allowed rpm	2950 (101%)
	minimum allowed rpm	700 (24%)
	Engine acceleration response from idling to maximum power, not more	3 seconds

## 6. SOME PRACTICAL AERODYNAMIC DATA OF YAK-52

Engine rotation moment, kg·m	170
Climb angle at maximum power setting (H=500m, speed=140 kmph),	12 7
Descent L/D ratio (landing gear and flaps retracted)	550
Power plant thrust at zero air speed, kg	140
Roll rate, degrees per second	

## 7. YAK-52 MANOEUVRABILITY

Acrobatic flights in our country are qualified to the following three stages:

1. Elementary: horizontal circle, horizontal eight, spiraldescending and climbing at angle up to 45 degrees, candle;
2. Advanced: half-cuban eight, .immelman, cuban, slow roll and spin roll, inverted half cuban eight, inverted cuban eight;
3. Unlimited: figures from Aresti catalogue.

Yak-52 allows to perform almost all figures from Aresti catalogue, including inverted flight figures.

## **8. EMERGENCY RECOMMENDATIONS**

### **8.1 ENGINE FAILURE**

#### **AFTER TAKE-OFF AND BEFORE THE FIRST TURN:**

- 1.set descent attitude of airplane;
- 2.retract landing gear;
- 3.close fuel cut-off valve;
- 4.switch off magneto, battery and ignition;
- 5.open cockpit;

Do land straight before you turn aside if straight direction is dangerous for pilot's life.  
If it occurs AFTER THE FIRST TURN OR, for example, IN AEROBATIC ZONE, follow the airfield flight instruction (ask your instructor for it).

#### **If it occurs IN INVERTED FLIGHT OPERATION:**

1. perform half-roll;
2. set 170..180 kmph descent air speed;
3. fix throttle in one-third of full range position;
4. turn primer 45 degrees left and build up 0.1..0.2 kg/cm<sup>2</sup> fuel pressure;

Additional in-cylinder fuel injection is recommended (primer to the right)

Engine restart after inverted position flight engine failure leads to 300..350 m altitude loss!  
At the moment of engine restart, give full throttle for 1..2 seconds; then set desired engine power setting.

### **8.2 OIL PRESSURE DROP**

1. check oil temperature, if oil temperature grows up, then land immediately to airfield or suitable site;
2. otherwise thoroughly monitor temperature and return to airfield for landing as soon as possible.

### **8.3 EMERGENCY LANDING ONTO GROUND**

should be carried out with landing gear retracted.

### **8.4 FUEL PRESSURE DROP**

1. turn primer 45 degrees left and pump on fuel to fuel system;
2. perform quick landing.

### **8.5 ENGINE SHAKING**

1. in all cases (except fuel pressure drop) minimize RPM and set airplane to descent angle;
2. if shaking ceased, carefully move throttle forward enough to maintain level flight;  
if engine continues shaking after varying engine power setting, increase engine RPM to 72% to burn spark plugs;  
if engine still continues shaking, find a proper power setting with minimum shaking and land as soon as possible.

### **8.6 PROPELLER OVERSPEEDING**

Symptoms:

Shallow engine vibration, rpm rise, leap of sound of running engine

If it occurs DURING TAKE-OFF:

during take off run – cancel take off, taxi to the parking site, ascertain the reason;

After lift-off – by slightly pulling backwards propeller pitch control lever set increase pitch, continue take off without changing manifold pressure, retract undercarriage at 15-20 m [50-65 ft] altitude, carry out usual circling flight and land at the airfield.

## 8.7 FIRE IN FLIGHT

1. Close fuel cut-off valve;
2. Set airplane to descent attitude;
3. If necessary, perform slip to choke flame;
4. Perform emergency landing.

If it is impossible to extinguish fire and emergency landing appears dangerous- leave aircraft with parachute.

Do not increase speed- it can lead to considerable fire intensity!

## 8.8 EMERGENCY EXTENSION OF LANDING GEAR

If it is impossible to extend the landing gear by common way use emergency extension with following sequence of actions is recommended:

check an emergency air system pressure (normal air pressure is 40..50 kg/cm<sup>2</sup>, if air pressure is at least 20 kg/cm<sup>2</sup>, one could try to extend the landing gear);

close main air system cock to prevent compressed air loss in case non-return valve fails;

set the landing gear controls to neutral position in both cockpits;

decrease air speed to minimum;

open an emergency landing gear extension cock on the right board of cockpit;

check landing gear extension by means of green warning lamps;

close the emergency system after engine shutdown;

It is not recommended to extend landing gear by landing gear controls from neutral position because it leads to damages to landing gear fittings.

Do not remove landing gear in flight after emergency extension!

## 8.9 LANDING WITH RETRACTED LANDING FLAPS

Descending air speed at final approach should be increased up to 160..170 kmph; landing with retracted landing flaps presents no considerable difference as compared with usual landing;

It should be kept in mind that all landing distances and airspeed will be somewhat bigger than during usual landing.

## 8.10 RADIO COMMUNICATION FAILURE

In all cases of sudden radio communication failure first check :

1. headphones connection;
2. "YKB" (VHF) switch is in on position;
3. if volume knob is in "maximum" position;
4. correct setting of radio station frequency;

If one fails to resume radio communication, it is necessary to show this by flying over landing runway at altitude of 200 m [660 ft] with landing gear extended. Before landing look carefully at landing signs and flares (green or red).

## 8.11 LEAVING AIRCRAFT WITH PARACHUTE

It is complicated task to leave aircraft at air speed, higher than 200 kmph.

Instructor gives a preliminary command "PREPARE TO JUMP" and executive command "JUMP" to leave the controllable aircraft, or only "JUMP" if aircraft is out of control.

Leaving aircraft at the altitude less than 150 m [500 ft] is dangerous.

The most reliable way of leaving aircraft is from inverted position at low air speed.

To leave an aircraft one should:

1. open cockpit canopy;
2. increase flight altitude and slow air speed (if possible);
3. set inverted level flight (if altitude allows);
4. pull your legs to the seat;

For leaving aircraft **IN INVERTED POSITION**:

5. bunch your body;
6. open seat belts lock and push stick forward immediately;



For leaving aircraft **IN LEVEL FLIGHT**:

5. open seat belts lock;
6. lift and pull your parachute out of the seat;
7. in stooped position stand up with feet into the chair seat place;
8. turn body to the side of jump;
9. put hands at back side of cockpit canopy and to the canopy reel;
10. put knees onto the canopy reel;
11. push out of the cockpit and leave the aircraft with head down;

Front cockpit should be left first.

After leaving the aircraft open parachute.

If aircraft is in fire, wait 3..5 seconds before opening the parachute 1 if possible- close fuel cut-off valve, switch off magneto, ignition, battery, generator.

## **9. DATA AND RECOMMENDATIONS FOR FORCED LANDING WITHOUT POWER**

Lift to drag ratio of Yak-52 airplane is  $K=7$  with retracted landing gear and  $K=5.5$  with extended. So the descent distance could be calculated as:  $L = K \cdot H$

Where  $H$  is airplane's altitude. Recommended descending speed to obtain maximum descent distance is 160 kmph without wind, 150 kmph with 5 m/s downwind and 170 kmph with 5 m/s headwind.

Headwind 5 m/s decreases descent distance by about 10%.

The most favourable turns are performed at 45 degree bank at 170 kmph air speed, the altitude loss is about 110 m within 12.. 15 seconds for such 180 degree turn.

## **10. GROUND SAFETY**

A high percentage of accidents in aviation occur during ground operations of aircraft and equipment. Failure to observe rules of safety is certain to cause problems. Pilots should be familiar with safety measures relative to fire and contamination hazards during fuel servicing, taxiing and parking aircraft, entering and leaving aircraft, pre- and post flight procedures, such as positioning of switches and controls, the proper installation of fuel and oil tank filler caps, etc.

## **11. FLIGHT SAFETY**

When operating in the seemingly unlimited space of the sky it is easy to forget that many other aircraft are flying in the area. The pilot must maintain a continuous vigilance for other aircraft around, above and below.

## SECTION 2. PREPARATION FOR FLIGHT

Prior performing aircraft visual inspection, pilot should accept the mechanic's report concerning the aircraft readiness for the flight. Check presence of chocks under main gear wheels and fire extinguishing aids near the aircraft.

### 1. VISUAL INSPECTION OF THE AIRCRAFT

To a pilot, the airworthiness of the aircraft is both a legal obligation and a direct responsibility. Careful personal attention to pre-flight procedures is the mark of a safe pilot and will be repaid not only in safety, but in lower aircraft maintenance costs.

As the pilot approaches the aircraft, external visual inspection should be started by looking for hazardous obstructions in the parking area, and for oil and fuel leaks under the aircraft. All tie-downs, control locks should be removed and the general appearance of the aircraft checked for signs of damages such as cracks or scratches. Then, the pre-flight inspection, should be performed in the following order:

1. Check the absence of incidental stuff under the engine which can damage propeller at engine starting;
2. Check propeller and spinner for defects or nicks;
3. Check propeller blade installation according to the incidence marks;
4. Check engine cowl flaps for defects or deformations;
5. Chock engine cowl for deformations, for fuel leaks. Locks must be properly closed;
6. Check if oil cooler plug is removed, inspect oil cooler condition and check it for absence oil leaks;
7. Check gear wheels for proper pressure in tires;
8. Check the amount of shock absorber rod extension (main struts- 120 mm, nose strut- 131 mm);
9. Check shock absorbers for oil leaking;
10. Check right wing skin, aileron and landing flaps for damage and deformations. Check if control surface locks are removed and ailerons can be deflected easily;
11. Inspect fuselage from below for skin damage, fuel leaks;
12. Inspect fuselage right side for skin damage;
13. Check the aerial wire fastening and its condition;
14. Check empennage for surface damage and deformation, check condition of elevator and rudder hinge connections. Check if control surface locks are removed and controls can be deflected to their full range;
15. Check fuselage left side for skin damage, locks of inspection hatches must be closed;
16. Check left wing casing and hatches for damage. Check if control surface locks are removed and ailerons can be deflected easily. Check landing flaps for surface damage and deformations;
17. Check Pitot tube condition. Make sure cover is removed;
18. Check if stall sensor DS-1 cover is removed;
19. Check fuel amount in tanks (visually). When tanks are full (121 litre), fuel level must be below tank neck for 30 mm [1.2"]. Check fuel level indicator readings in the aircraft cockpit. Check oil level using ruler gauge. Maximum oil capacity is 16 litres for non-aerobatic flights; 10 litres for aerobatic flights, minimum- 8 litres. Secure the tank caps.

## 2. PILOT'S ACTIONS BEFORE ENTERING THE AIRCRAFT

Before entering the aircraft cockpit (front) check windshield and cabin canopy for cleanliness.

1. Check the cockpit for the absence of loose articles;
2. Check the seat for reliable fastening and for absence of damage;
3. Check the seat belts for attachment reliability;
4. Check if magneto switch is set to "0" position;
5. Check if engine starting button is covered with protective cap;
6. Check that all switches are turned off;
7. Check if landing gear operation control jack is in "Landing gear extended" position and locked by gear control latch. Check if landing flaps control is in neutral position;
8. Set brakes on. Then you should adjust the parachute belts, put down the parachute into the seat and fasten the parachute instrument rope carbine to the seat brace.

Before entering rear cockpit you should check additionally:

if "Ignition" switch is set to "First cockpit" position;

if gear control is set to neutral position and closed by the latch;

if landing flaps control is set to neutral position.

## 3. PILOT'S ACTIONS AFTER ENTERING THE AIRCRAFT

### In front cockpit:

1. Adjust pedals in accordance with leg length. They should be adjusted so that you have full pedal travel whenever necessary;
2. Check belt lock operability. It is very important to have reliable locks, especially for aerobatic flights;
3. Fasten your seat belts and stiffen waist-belts and middle belt first, then shoulder-belts, check the seat belts lock for reliable closing;
4. Connect headset cord holder and on-board connector of the aircraft intercom;
5. Check if cockpit movable part can be closed and opened easily, if cockpit locks are reliable in opening and closing;
6. Check flight controls for freedom of movement;
7. Check elevator trimmer tab wheel for freedom of movement and set it to "Back" position;
8. Check surface condition of flight and engine instruments;
9. Check magnetic compass KI-13 readings. Compass must indicate parking course of the aircraft;
10. Set altimeter pointers to "0", indicator scale pressure readings must coincide with actual pressure value (ground pressure). 1.5 mm mercury deviation is allowed;  
Warning: In cases, when deviation between indicator pressure readings and actual ground pressure value (meteorological station data) is more than 1.5 mm mercury column, flight is forbidden.
11. Set G-meter pointers to initial position;
12. Check board clock readings, wind it up if necessary, and set exact time;
13. On radio station control panel set squelch to "OFF" position (down), volume knob- to maximum volume position.

### In rear cockpit:

14. Check every switch position on "Instrument Failures Simulator" panel- they must be in "OFF" (down) position;
15. Check if "GENERATOR" switch is set to "FIRST COCKPIT" position;
16. Check if braking lever retainer is free. Check if parking brakes are released;

### In front cockpit:

17. Open air system cock and check air pressure in main and emergency air systems: it must be not less than 50 kg/cm<sup>2</sup>;

Air tightness of braking system. When parking lever is fully depressed, pedals are neutral, you would not hear hissing of leaking air; wheels braking-off system work, to check it you need to brake-off wheels from rear cockpit, when braking lever in front cockpit is depressed.

18. Check the throttle, propeller pitch control, fuel cut-off valve for free movement. Set fuel cut-off valve to-"Open" position (fully forward);

Check throttle lever movement when fuel cut-off valve is closed.

19. Check engine cowl flaps, oil cooler flaps and air heating gate at carburettor inlet for free movement.

## 4. ENGINE STARTING, WARMING-UP AND GROUND TEST RUN

When ready to start the engine, pilot should look around in all directions to be sure that nothing is or will be in the vicinity of the propeller and that nearby persons and aircraft will not be struck by the propeller blast or the debris it might pick up from the ground. Then pilot should carry out the following;

1. Ensure that propeller control is set in "FINE PITCH" position;
2. Set throttle to the position, corresponding to 1/3 of its full travel (28-38%);
3. Set fuel cut-off valve to "OPEN" position (full forward);
4. Set carburettor heat control to "WARM-UP" position (full back), if outside temperature is below freezing;
5. Ensure that magneto switch is turned off (in "0" position);
6. Ensure that "AIRFIELD SUPPLY-OFF-BATTERY" switch is in "OFF" position, "IGNITION" switch is turned off (down position);

Give command "Crank the propeller". In the process of cranking prime the engine (5-6 times in summer and 8-12 times in winter). Then set the primer to "MANIFOLD PRIMING" position and build up fuel pressure at carburettor inlet 0.2–0.5 kg/cm<sup>2</sup>.

Warning: 1. Hand cranking is necessary when the engine is cold. When it is warm, hand cranking is forbidden.

Warning: 2. It is dangerous to prime fuel more than 5-6 times in summer and 8-12 times in winter, because it fuel may wash oil from cylinder walls, that will result in piston sticking up, or fuel can be accumulated in lower cylinders, that can result in hydraulic shock.

One can start the engine using battery or ground electric power supply.

1. Set wheel brakes;
2. Give command "CLEAR PROPELLER", after receiving mechanic's answer "PROPELLER'S CLEAR", switch on "BATTERY", "IGNITION", "GENERATOR", "UC WARNING" and "ENGINE INSTRUMENTS" switches;
3. Open the button "ENGINE STARTING" cap and press the button for 3-5 seconds;
4. When propeller starts rotating (makes 3-5 revolutions), switch magneto ON (set magneto switch to "1+2" position);

Note: 1. For better engine starting it is recommended to prime the engine few more times.

5. It is allowed to help the engine to work steady by moving the throttle forward and back (in RPM range 28-60%)

If engine won't started during 30 seconds, turn off "MAGNETO" switch and crank propeller for 8-10 revolutions in its rotation direction. Then repeat starting procedure.

Note: While activating the engine starting button one hand should be kept on the throttle, to be ready to advance the throttle if the engine falters while starting or to prevent excessive RPM just after it starts.

6. When engine runs steadily, release starting button and set throttle to position, corresponding to RPM 38-41%. Watch the oil pressure. If it doesn't rise to 1 kg/cm<sup>2</sup> in about 15-20 seconds after engine start, it is necessary to shutdown the engine and find out the reason.

7. After you've started the engine, lock primer in its vertical position, cover the starting button by the cap.

8. Engine warming-up. You should warm-up the engine at RPM 41-44% until the engine inlet oil temperature starts rising. After this you should increase RPM up to 44-48% (in winter- 51%) and warm-up the engine until cylinder heads temperature (CHT) is 120°C and the engine inlet oil temperature is 40°C. In winter engine cowl flaps must be closed (and oil cooler flap as well).

9. The engine is considered warm when the CHT is not less than 120°C, engine inlet oil temperature is not less than 40°C.

10. After engine is warmed, warm up the propeller by moving twice a propeller pitch control lever from "FINE PITCH" position to "COURSE PITCH" position and back.

### 11. ENGINE TEST RUN

Open engine cowl and oil cooler flaps.

12. Test run the engine at the second nominal power setting. Open the throttle completely and smoothly, then set RPM 70% using propeller pitch control.

Instrument readings must be as follows:

RPM	70%
Manifold pressure	75+15 (excessive)
Fuel pressure	0.2 – 0.5 kg/cm <sup>2</sup>
Oil pressure	4-6 kg/cm <sup>2</sup>
Cylinder head temperature	120- 220°C
Carburettor inlet air temperature	+10- +45°C
Engine inlet oil temperature	40- 75°C

Engine should run smoothly.

To avoid engine overheating due to insufficient ventilation, the prolonged engine run at the second nominal power setting is not recommended.

13. Check each magneto and spark plugs for operation:

Set the propeller control to "FINE PITCH" position. Set RPM 64-70% using throttle.

Turn the second magneto OFF for 15-20 seconds and memorize RPM drop.

Turn both magnetos ON.

RPM drop when running on one magneto must not exceed 3%.

14. Check generator operation.

Set RPM 57-58% using throttle, when pressing voltammeter button, the voltage must be 27-29V.

When generator is ON, "GENERATOR FAILURE" red signal lamp must go OFF.

15. Check propeller and propeller governor operation.

Ensure that propeller pitch control lever is set to "FINE PITCH" position.

Set RPM 70% using throttle lever. Move the propeller control to "COURSE PITCH" position (full back), RPM must drop to 53%.

Move the propeller pitch control lever to "FINE PITCH" position (full forward), RPM must increase up to 70%. Short oil pressure drop at the engine inlet up to 2 kg/cm<sup>2</sup> is permitted with subsequent recovery within 8-11 second.

16. Check the propeller and propeller governor at balance RPM.

Propeller control lever is in "FINE PITCH" position. Set RPM 70% using throttle.

Set RPM 64% using propeller control lever.

Moving the throttle smoothly forward and backward (not to extreme positions), check that RPM remain constant.

If you move the throttle forward and backward too sharp, the engine speed may increase or decrease for 2-4% respectively, but it will restore in 2-3 seconds.

17. Check engine run at 1-st nominal (82%) power setting during 20-30 seconds (propeller control lever is in "FINE PITCH" position).

Instrument readings must be as follows:

RPM	99+1%
Manifold pressure	125+15 (excessive)
Fuel pressure	0.2 – 0.5 kg/cm <sup>2</sup>
Oil pressure	4-6 kg/cm <sup>2</sup>
Cylinder head temperature	120- 220°C
Carburettor inlet air temperature	+10- +45°C
Engine inlet oil temperature	40- 75°C

18. Check the engine run at minimum RPM (propeller control is in "FINE PITCH" position, throttle is in "IDLE" position). The engine must work smoothly. Instrument readings must be as follows:

RPM	26%
Fuel pressure	not less than 0.15 kg/cm <sup>2</sup>
Oil pressure	not less than 1.0 kg/cm <sup>2</sup>
Cylinder head temperature	120- 220°C
Carburettor inlet air temperature	+10- +45°C
Engine inlet oil temperature	40- 75°C

To avoid spark plugs oiling, run engine at minimum RPM not longer than 5 minutes.

19. Check the engine acceleration response to maximum RPM. It must not exceed 3 seconds.

Note: When idling the throttle, the short revolutions drop is permitted.

## **5. ATTITUDE INDICATOR AGI-1. SWITCHING ON AND CHECKING**

Before switching attitude indicator press against stop "Press before start" button and then release it.

Switch on AGI circuit breaker, located on electrical panel and watch its readings. Approximately 1 minute after been powered attitude indicator should show aircraft attitude regarding the horizon.

## **6. RADIO STATION SWITCHING ON AND CHECKING**

1. Turn "VHF" and "INTERCOM" switches ON. In 2 minutes the radio station is ready for operation.

2. Check the required communication frequency on the radio station control panel.

3. Check the radio station operation by establishing communication with the ground radio station or by self-listening during transmission.

## **7. PREPARATION OF REAR COCKPIT BEFORE SOLO FLIGHT**

Solo flights are carried out from front cockpit only.

One should check rear cockpit:

for absence of loose articles;

if "IGNITION" switch is in "1 COCKPIT" position;

if magneto switch is in "1+2" position;

if landing gear control is in neutral position and locked by the latch;

if "BRAKING-OFF" switch is in "OFF" position;

if landing flaps control is in neutral position;

if all switches on "INSTRUMENT FAILURE SIMULATION" panel are in "OFF" position;

if "GENERATOR" switch is in "1 COCKPIT" position;

if the parachute is taken out of the cockpit;

seat-belts must be fastened firmly;

movable part of the canopy must be locked.

## **8. ENGINE SHUTDOWN**

1. Set the parking brakes ON;

2. Set the throttle to IDLE or 40% RPM;

3. Turn "VHF"), "ADF", "AGI-1K" switches OFF. If necessary, cool down the engine, until CHT is 140-150°C. It is not recommended to shut down the engine if the CHT exceeds 140-150°C limit. Before the engine shutdown you should avoid the prolonged engine run at minimum RPM;

4. Increase RPM up to 65-68% (using throttle) for 20-30 seconds to burn sparking plugs;

5. Decrease RPM to 28-34% (using throttle);

6. Set magneto switch to "0" position;

7. After the engine shutdown set the throttle to IDLE position and close the fuel cut-off valve;

8. Turn all other control panel switches OFF;

Warning: You are forbidden to shutdown the engine:

a) after the engine run at cruise power settings;

b) by closing the fuel cut-off valve and fuel working out of the carburettor (to avoid back flash and fire).

9. Close the air system cock;

10. Shut the engine cowl flaps;

11. Shut the oil cooler flaps;

12. Close the cockpit cover;

13. Put chocks under wheels.

## **SECTION 3. PATTERN FLIGHT**

### **1. PREPARATION FOR TAXIING**

An awareness of other aircraft which are taking off, landing or taxiing and consideration for the right-of-way of others is essential to safety. To observe the entire area pilot's eyes must cover almost a complete circle. So, after you've convinced of normal engine run, instrument panel and radio communication good operation, you should look around: left-back: if there are any obstacles or people near the aircraft tail; left: if there are any other aircraft taxiing; left-ahead: if there are any obstacles and people in front of your aircraft. Then you should look around in right direction while taxiing, the pilot must be sure the aircraft wings will clear other aircraft. Then you are to ask the controller for the permission to taxi. After getting it, idle the throttle, check up the tightness of your seat-belts give command "PULL CHOCKS" with your hands motion to the sides. Then the brakes should be tested for proper operation: release the fixative of the parking brakes; set the rudder pedals and the stick to neutral position; put on the brakes and open the throttle, the aircraft must keep it's place at RPM up to 75X (depending on the ground surface condition). If braking action is unsatisfactory, the engine should be shutdown immediately. After brakes' test close the throttle again, ask for the mechanic's permission to taxi by your left hand lifting, close the cockpit's canopy and check its lock reliability (press down the left lock handle and pull both handles backwards). Then open the throttle to begin taxiing in the initial direction. If you begin taxiing smoothly, the aircraft doesn't change the direction.

### **2. TAXIING**

It is difficult to set any rule for a safe taxiing speed. The primary requirement of safe taxiing is the ability to stop or turn where and when desired. Normally, the speed should be at the rate where movement of the aircraft is dependent on the throttle, that is, slow enough be when the throttle is closed the aircraft can be stopped promptly. Use the brakes very smoothly. There's an insignificant tendency to turn to the right during taxiing, it can be easily counteracted by the left rudder pedal pressure and the brakes' use'. To achieve the normal engine run you should preserve RPM 40% during taxiing. Note: The prolonged engine run with the idle throttle is not recommended because of sparking plugs covering with oil wrap. Except while taxiing very slowly, it is best to slow down before attempting a turn. Otherwise, the turn may have too great radius or could result in an uncontrollable swerve or a ground loop. Very sharp turns or attempting to turn at too great speed must be avoided. The rudder pedals and brake lever on the stick are directional controls while taxiing. To turn the aircraft on the ground, the pilot should apply rudder in the desired direction of the turn and use whatever power or brake that is necessary to control the taxi speed. The rudder should be held in the direction of the turn until just short of the point where the turn is to be stopped, then the rudder released or alight opposite pressure applied as needed. After you reach a holding position you should make the pre-take off check. It is a last minute check of the engine, controls, systems, instruments and radio before flight. Taxiing to that position usually allows sufficient time for the engine to warm up to at least minimum operating temperatures and ensures adequate lubrication of the internal moving parts of the engine before being operated at high power settings.

The following are some of the major items that should be checked or set before moving onto the take off runway:

1. Check flight controls for free and proper operation;
2. Set trim tabs for take off ("BACK" position);
3. Adjust altimeter to reported altimeter setting or airfield pressure;
4. Set propeller control to FINE PITCH;
5. Check engine temperature;
6. Check engine instruments for normal readings;
7. Obtain take off runway clearance;
8. Check canopy locked;
9. Check runway and final approach for aircraft.

•While taxiing onto the runway, the pilot can select ground reference points that are aligned with the runway direction as aids to maintaining directional control during the take off. These may be distant trees, towers, buildings, etc., after taxiing onto the runway, the aircraft should be carefully aligned with the intended take off direction, and the nose wheel positioned straight or centred. Then you should idle the throttle and stop the aircraft. Set the take off course according to the heading indicator (KAU-4), check the attitude indicator readings .

Ensure that the landing flaps are retracted. Keeping the stick and pedals in neutral position, holding the brakes on, open the throttle up to RPM 54-57% and obtain the controller's clearance for the take off. After that. turn on the clock, burn through the sparking plugs (RPM = 70%). Engine gauge readings must be the following:

cylinder head temperature	120- 220°C
oil pressure	4-6 kg/cm2
oil temperature	40- 75°C
fuel pressure	0.2 - 0.5

If engine gauge readings don't meet these requirements, the take off is prohibited. If everything is OK, you may start the take off roll.

### 3. TAKE OFF ROLL

Note: An abrupt application of power may cause the aircraft to yaw sharply to the right because of the torque effects of the engine and propeller. So, with this in mind, the throttle should be always advanced smoothly and continuously to prevent any sudden swerving. The engine gauges should be monitored during the take off so as to note immediately any malfunction or indication of insufficient power. The stick must be in neutral position. There is an insignificant tendency of the aircraft to turn to the right at the beginning of the take off roll. You should compensate this tendency by the left pedal pressure applying. The take off roll is short, speed is picked up quickly. As speed is gained, the stick will tend to assume a neutral position if the aircraft is correctly trimmed. At the same time, directional control should be maintained with 'smooth, prompt rudder corrections throughout the take off roll. So, attention distribution during the take off roll:

- to the directional control;
- to the throttle smooth advancement;
- to the engine run monitoring by ear and engine instrument indications;
- to the determination of the nose wheel lifting moment.

As the speed continues to increase, all the flight controls will gradually become effective enough to operate the aircraft.

### 4. LIFT-OFF

When you reach speed 90 kmph (it is determined by the passing glance to the airspeed indicator), lift the nose wheel to attain the take off attitude. A good take off depends on the proper take off attitude, as it is important to know how it is attained. At speed 90 kmph, when all the flight controls become effective, back elevator pressure should be gradually applied to raise the nose wheel slightly off the runway, thus establishing the take off or lift-off attitude. The position of the nose in relation to the horizon should be noted, then



elevator pressure applied as necessary to hold this attitude. The wings must be kept level by applying aileron pressure as necessary. The aircraft must be allowed to fly off the ground in this normal take off attitude. Forcing it into the air by applying excessive back pressure would only result in an excessively COURSE PITCH attitude and may delay the take off. Excessive and rapid changes in pitch attitude result in making the aircraft more difficult to control. If the aircraft is forced to leave the ground by using too much back pressure before adequate flying speed is attained, the wing angle of attack may be excessive, causing the aircraft to settle back on to the runway or even to stall. On the other hand, if sufficient back elevator pressure is not held to maintain the proper take off attitude after becoming airborne, or the nose is allowed to lower, the aircraft may settle back on to the runway. It is important, then, to hold the attitude constant after lift-off.

Attention distribution during the take off roll in lift-off attitude!

to the take off attitude maintenance;

to the directional control;

to the engine run check by ear;

to the determination of lift-off moment. YAK-52 lift-off speed is 120 kmph.

## **5. INITIAL CLIMB**

After lift-off, the aircraft should be flying at approximately the attitude which will allow it to accelerate to speed 160 kmph. The aircraft picks up speed rapidly after it becomes airborne. Since the power during the initial climb is fixed at the take off power setting, the airspeed must be controlled by making slight pitch adjustments using the stick (elevator). However, you shouldn't stare at the airspeed indicator when making these slight pitch changes, but should watch the attitude of the aircraft in relation to the horizon. When the correct pitch attitude has been attained, it should be held constant while cross-checking "speed-attitude" against the horizon and other visual references. After the aircraft lift-off you should shift your eyes to the ground- to the left from the aircraft longitudinal axis for 25-300 and ahead for 25-30 m- and watch the altitude and attitude.

Attention distribution during the initial climb:

to the directional control;

to the absence of banks, skips, slips, drift.

The drift can be determined by the look to the ground surface: if you have the right drift, the ground "comes out" from under the aircraft (moves left-backward), if you have the left drift, the ground "goes" under the aircraft.

The initial climb speed is 170 kmph.

When you gain speed 170 kmph, move on to the climb and simultaneously shift your gaze ahead along the cowl, having the ground reference in the field of vision to maintain the take off direction.

Climbing speed is 170 kmph.

## **6. CLIMB**

After the recommended climbing airspeed has been well established and altitude 20 m has been reached, the landing gear should be retracted.

1. Draw the gear control catch aside;

2. Move on the gear control from "EXTENDED" position to "RETRACTED" position, passing neutral position;

3. Check the landing gear retraction (red signal lamps and mechanical indicators). When the gear is retracted, green signal lamps must burn;

4. Trim the aircraft to relieve the control pressures. This will make it much easier to hold constant attitude and airspeed.

Then the power should be adjusted to the recommended climb setting. It is the first nominal power setting of the engine run. You should close the throttle for 25-30 mm of mercury column and then smoothly decrease RPM to 82% by the propeller control. Note: It is not recommended to decrease RPM without preliminary throttle closing. To move on to the operation at higher power settings you should increase RPM up to the assigned value by the propeller control first, then open the throttle.

## **7. CROSSWIND TAKE OFF AND CLIMB**

While it is usually preferable to take off directly into the wind whenever possible, there are many instances when circumstances indicate otherwise. Consequently, the pilot must be

familiar with the principles and techniques involved in crosswind take offs as well as those for normal take offs. The technique used during the initial take off roll in a crosswind is generally the same as used in normal take off, except that the aileron must be held INTO the crosswind. While keeping the wings level with the aileron control, the take off path must be held straight with the rudder. Normally, this will require applying downwind rudder pressure since on the ground the aircraft will tend to weathervane into the wind. As the forward speed of the aircraft increases and the crosswind becomes more and more of a relative headwind, the aileron holding into the wind should be reduced, because the ailerons are becoming more effective. It is important to hold sufficient aileron into the wind not only to keep the upwind wing from rising but to hold that wing down so that the aircraft will, immediately after lift-off, be slipping into the wind enough to counteract drift, but be careful; the aircraft must take off from two main wheels, not one. To avoid the drift after the lift-off you should hold the aileron into the wind and apply the rudder pedal pressure to counteract the tendency to turn (opposite to the bank). This slipping should be continued until the aircraft has climbed well above the ground. At that time the aircraft should be headed toward the wind to establish just enough "crab" to counteract the wind and then the wings rolled level. The climb while in this "crab", should be continued so as to follow a ground track aligned with the runway direction. In other respects the take off techniques and attention distribution are the same as for the typical take off with the head wind.

## 8. TYPICAL MISTAKES IN THE COURSE OF THE TAKE OFF

### 1. During the take off roll:

if you don't use maximum allowable power (not a full throttle), the length of the aircraft take off roll increases;

an abrupt application of power may cause the aircraft to yaw sharply;

the aircraft is not kept from the turn to the right?

unnecessary precaution from the turn to the right makes aircraft turning to the left;

creating of the aircraft take off attitude when the speed is more than 90 kmph leads to the three wheels lift-off;

the stick pulling back at speed less than 90 kmph leads to the lift-off at low speed;

the take off attitude is excessively high, this leads to the lift-off at low speed, stall is possible.

### 2. During the initial climb:

if sufficient back elevator pressure is not held to maintain the correct take off attitude after becoming airborne or the nose is allowed to lower excessively, the aircraft may settle back to the runway or blow the nose wheel over the ground;

banks during the initial climb can lead to the drift;

the initial climb speed (170 kmph) is more than required, that's why you can move on to the climb with the increased speed.

## 9. UPWIND LEG

After the landing gear is retracted and you have the climb power setting (the first nominal power setting), check up instrument readings:

cylinder head temperature	140-190°C
inlet engine oil temperature	50-65°C
fuel pressure	0.2-0.5 kg/cm <sup>2</sup>
oil pressure	4-6 kg/cm <sup>2</sup>

Then set speed 170 kmph, look around, if there are any other aircraft, which can be on our way in the following sequence: left-ahead, left-side (up and down), right-ahead, right-inspection (up and down). In the course of the climb watch your speed, altitude and attitude. The pilot should cross-check the airspeed indicator, attitude indicator and the position of the aircraft nose in relation to the horizon. Watch the absence of banks. At the same time a constant heading should be held. (Nose-up elevator trim should be used to make the aircraft more controllable.).

## 10. THE FIRST TURN

Before performing the first turn (H=130-150 m) you should look around, (to the turn direction- down, back, up, ahead) if there are no aircraft which can be in your way during the turn carrying-out. Look for emergency landing grounds.

Performing the climbing turns, the following factors should be considered:

1. With a constant power setting the same pitch attitude and airspeed can not be maintained in a bank as in a straight climb due to the decrease in effective lift and airspeed during a turn.
2. The degree of bank should be neither too steep nor too shallow. The bank in the course of the turns must be 30 (for YAK-52);
3. The coordination of all controls is a primary factor to be stressed.

Then you should choose a ground reference for the aircraft rollout. When wind velocity is less than 5m/sec, the ground reference must be situated at an angle of 90° to flight direction, when wind velocity is more than cm/sec- this angle must be less than 90°. In any case, the aircraft flight path after the first turn must be perpendicular to the line of the landing Tee. When you reach 150 m altitude, ensure that your speed is 170 kmph. To maintain this speed before starting the turn you should push slightly the stick forward. Then, by applying smooth and coordinate pressure stick and rudder pedal you should roll into the turn. Attention distribution during turn starting:

to the gradual bank increase to the bank angle maintenance (it must be permanent);

to the indicator readings (speed, "ball" position in slip indicator, heading, bank magnitude according to attitude indicator).

Bank angle should not exceed 30°.

When you reach bank 30°, keep it permanent by slight coordinated aileron and rudder pressures to the side, opposite to the bank. You should maintain the speed and the bank, keep the "ball" in centre. Attention distribution during the turn:

to the bank sustentation;

to the indicator readings (speed, "ball" position, bank magnitude, heading);

look in the turn direction, if there are any other aircraft not far from yours.

20-25° before the ground reference (or assigned magnetic heading), the rollout to a desired heading must be started. To do it, coordinated aileron and rudder pressures should be applied to roll the wings level and stop the turn. Speed must be 170 kmph.

Attention distribution during the rollout:

to the simultaneous bank and the aircraft angular velocity decrease;

to the indicator readings.

### ***TYPICAL MISTAKES DURING THE FIRST TURN***

#### 1. Starting the turn:

low speed at the turn starting, this can result in the turn carrying-out at greater angles of attack than it is necessary to obtain best climb;

vertical rudder pressure is applied in the direction of the turn (especially during the right turn)- you start the turn with the skidding ("ball" deviates to external side);

you are late with rudder pedal pressure at the turn starting in respect to the bank making- this can result in the sliding ("ball" deviates to internal inspection).

#### 2. In the course of the turn:

the assigned speed is not maintained, vertical rudder deflection is excessive- this leads to the quick aircraft turn with the tail drift ("ball" deviates to external side);

vertical rudder deflection is insufficient, aircraft turns sluggishly ("ball" deviates to internal side).

#### 3. During the rollout:

uncoordinated aileron and rudder pressures (the aircraft hasn't finished the rotation yet, rudder pedals have not been set to neutral position but the wings has rolled level) can lead to the aircraft rollout with the tail skidding;

the turn is performed for more or less than 90°, this results in the unpunctual rollout.

## 11. CROSSWIND

After you have rolled the wings level and stopped the turn, check your speed, it must be 170 kmph, check the rollout direction in respect to the landing Tee line (ground references and heading indicator), make necessary corrections and look around:

left-ahead, left-side, left-down and left-up- to check the accuracy of the heading, to see, if there are any other aircraft which can be in your way;

left-back- if there are any other aircraft, taking a short cut;

right-ahead, right-side, right-down and right-up- to check the heading accuracy, to see if there are any aircraft, which can be in your way;

right-back- if there are any aircraft, passing you. Carrying on the climb, you should determine the moment of the second turn starting and keep your eye on altitude. If you've gained altitude 300 m before the second turn, you should set level flight from a climbing attitude. It is necessary to start the level-off approximately 20-30 m below the desired altitude. The nose must be lowered gradually, because loss of altitude will result if the pitch attitude is decreased to the level flight position without allowing the airspeed to increase accordingly. After the aircraft is in a level attitude, climb power should be changed to desired cruise power:

the throttle setting and the propeller control should be reduced to appropriate cruise power settings RPM=70%, speed=180 kmph. The aircraft should be re-trimmed.

## 12. THE SECOND TURN

Before the second turn carrying-out you should determine the distance between your aircraft and the aircraft in front of you- the distance between the aircraft must be not less than 1,5 km. You are allowed to come off the aircraft in front of you by late performing of the first and the second turns. You should start the second turn, when the angle between the longitudinal axis of your aircraft and glance line direction to the landing Tee is 45°. The airspeed must be 170 kmph in climbing and 180 kmph in level flight.

To maintain the speed before the turn starting in straight- and- level flight you should open the throttle (a little bit), after the aircraft rollout you should close the throttle (a little bit). Attention distribution is the same as in the course of the first turn carrying-out. The aircraft rollout onto the downwind leg should be performed in the direction, which is parallel to the landing Tee line. The compass heading must be equal to the reverse landing heading.

## 13. DOWNWIND

After turning onto the downwind you should check your speed. It must be 180 kmph. Engine throttle must be 470-490 mm of mercury column, RPM- 70%. The sequence of actions and attention distribution are the same as for the crosswind.

The pilot must know every minute, if there are any aircraft in the air not far from his aircraft, that's why you are recommended to make small smooth turns to the left and to the right for 10-15 to see the space around you. You should check the accuracy of your flight path, pattern width and that it is parallel to the landing Tee line.

The pattern width is defined by the landing Tee line projection in respect to the aircraft wing. If your pattern is correct, wing tip must pass along the landing Tee line, but it mustn't cover it. When you reach the landing Tee traverse, you should convince that the aircraft in front of you is not in your way to the third turn, that your path is parallel to the landing Tee line, you should check your altitude, airspeed, engine run, instrument reading. Then you should extend the landing gear.

It is recommended to open the throttle (insignificantly), move the gear control from "RETRACTED" position to "EXTENDED" position (passing neutral position). Check up, that the landing gear is extended with the help of mechanical indicators on the wing and signal lamps (three green lamps). Then lock the gear control catch. The aircraft should be re-trimmed. Then the pilot should call for the landing clearance from the tower (controller).

## 14. THE THIRD TURN

It is very important to make it in a proper place because the placement of the base leg is one of the most important judgments to be made by the pilot in any landing approach.

The pilot must accurately judge the altitude and distance from which a gradual descent will result in landing at the landing Tee. The distance depends on the altitude of the base leg, the effect of wind. When there is a strong wind on final approach, the base leg must be positioned closer to the approach end of the runway than would be required with a light wind. If your pattern is accurate (wind velocity 5-6 m/sec), you should start the third turn when the angle between the aircraft longitudinal axis and glance line direction to the landing Tee is  $45^\circ$ .

If the aircraft, which is flying in front of you, performs the third turn far from the landing Tee line or if the distance between your aircraft and the aircraft in front, of you is less than 1,5 km, you must perform the third turn in good time and go around, keeping the other aircraft under observation and maintaining your altitude.

The pilot must inform the controller of the situation.

The sequence of actions during the third turn is the same as during the first and the second turns.

## 15. BASE LEG

After turning onto the base leg, you should convince, that your speed is 180 kmph, then look around, count the aircraft on front of you and keep them under observation until they land and vacate the landing runway. Then check the engine temperature power setting (cylinder head temperature is not less than  $140^\circ\text{C}$ , oil temperature is no less than  $40^\circ\text{C}$ ) and, keeping the landing Tee line approaching under your observation, you should determine the moment of descent starting (with reduced power). You should idle the throttle, set the propeller control to "FINE PITCH" position then set descent speed 170 kmph. The aircraft vertical velocity must not exceed 4-5 m/sec. At the moment of throttling down the landing Tee line must be projected at an angle  $30^\circ$  (angle between the aircraft lateral axis and glance line direction to the landing Tee). Then look around:

left-ahead: to check up the accuracy of flight path direction and the presence of any other aircraft, gliding for the landing;

left-side (up and down); to check up the aircraft position in respect to the landing Tee line and to convince that there are no other aircraft;

left-back: if there are any other aircraft, taking a short out;

right-ahead: to check up the accuracy of flight path direction and to see if there are any aircraft, performing direct landing;

right-inspection (up and down): if there are any aircraft, joining the pattern;

right-back: if there are any aircraft, passing you.

To make your landing approach more accurate you are allowed to turn the aircraft, closer to the airfield (not more than  $20^\circ$  however), the bank must not exceed  $30^\circ$ .

Since the final approach and landing are normally to be made into the wind, there will be somewhat of a crosswind during the base leg. This requires that the aircraft should be angled (crabbed) into the wind to prevent drifting far away from, the landing Tee. If your landing approach is accurate, the altitude loss from the moment of descent starting to the fourth turn starting must be 50-100 m. The aircraft vertical velocity should be regulated using throttle closing and opening.

The base leg should be continued to the point where a medium-banked ( $30^\circ$ ) turn will align the aircraft path directly with the centre line of the landing runway.

## 16. THE FOURTH TURN

Before the turn carrying-out you should examine thoroughly the air space: if there are any aircraft not far from you; you should convince that you haven't taken a short cut for any other aircraft and there are no other aircraft gliding. You should start the base-to-final turn when the visual distance between the front part of the wing and the landing Tee line is 0.5 m, the angle between the landing Tee line and glance line direction to the landing Tee is  $15-18^\circ$ . The turn must be performed at speed 170 kmph.

It is recommended that the angle of bank doesn't exceed a medium bank, because the steeper the angle of bank, the higher is airspeed at which the aircraft stalls. Since the base-to-final turn is made at a relatively low altitude, it is vitally important that a stall not occur at this point. If an extremely steep bank is needed to prevent overshooting the proper final approach path, it is advisable to discontinue the approach, go around and plan to start the turn earlier on the next approach rather than risk a hazardous situation. The rollout should be started at approximately 20-25°, before reaching the final approach path (which must be aligned with the centre line of the landing runway). The altitude of the base-to-final turn rollout must be 200-150 m. The main attention in the course of this turn-to-final carrying-out should be given

## 17. FINAL APPROACH

Immediately after the base-to-final turn is completed, the longitudinal axis of the aircraft should be aligned with the centre line of the runway, so that drift (if any) will be recognized immediately. On a normal approach, with no wind drift, the longitudinal axis should be kept aligned with the runway centre line throughout the approach and landing. Set the gliding angle, corresponding to speed 160 kmph (regulate the speed using throttle). Then check if your final approach is accurate, if the landing gear is retracted, if the landing runway is vacant and there are no signs, forbidding the landing, if there are any other aircraft which can be in your way for the landing.

You are not recommended to close the throttle completely because in case of going around, (especially if your altitude is low) the aircraft gains speed very slowly when you open the throttle (because of the insufficient engine time gap)

Warning: You are forbidden to glide close to the aircraft in front of you (especially in its tail) with the hope that there's enough time for it to vacate the landing runway.

If something prevents your landing, you must execute a go-around, affirming the controller of your decision. If you are sure that nothing can prevent your landing, extend the landing flaps. To do it you should put the control of the landing flaps down. Check up that the flaps are down-signal lamp must burn (green). Then you should maintain speed 160 kmph. Slight adjustments in pitch and power may be necessary to maintain the descent attitude and the desired approach airspeed.

When the pitch attitude and airspeed have been stabilized, the aircraft should be re-trimmed to relieve the pressures held on the controls. The wind plays a prominent part in the gliding distance over the ground, the pilot may correct for its effect on the aircraft descent by appropriate pitch and power adjustments.

If your final approach is accurate, landing Tee projection must be in the middle of the front windshield, gliding path must be directed to the round-out point (100-120 m before the landing Tee).

If you have constant descent pitch attitude (speed 160 kmph), the landing Tee projection doesn't move up or down. It means that your approach is accurate. If the landing Tee projection is moving up- you are short, if the landing Tee projection is moving down- you are long. The gliding speed depends upon wind velocity:

when headwind velocity is not more than 10 m/sec- gliding speed is 160 kmph;

when headwind velocity is more than 10 m/sec (up to 15 m/sec)- gliding speed is 170 kmph.

Crosswind velocity must not exceed 6 m/sec, headwind velocity - 15 m/sec.

If your speed is less than 160 kmph:

-  $H < 50$  m- you should increase RPM and set the desired speed;

-  $H > 50$  m- you should press the stick forward, decrease the angle of attack,

increase RPM and set the desired speed.

If the pitch attitude is raised too high without an increase of power, the aircraft will touch down short of the desired spot. For this reason, never try to stretch a glide by applying back elevator pressure alone (without power change). It is dangerous and it will shorten the gliding distance, if power is not added simultaneously.

### FAULTY APPROACHES. APPROACH CORRECTIONS

#### 1. LOW FINAL APPROACH

When the base leg is too low, insufficient power is used or the velocity of the wind is misjudged, sufficient altitude may be lost to cause the aircraft to be well below the proper final approach path. Corrective actions: power must be applied immediately to maintain the airspeed while the pitch attitude is raised to increase lift and stop the descent. When the proper approach path has been intercepted, the correct attitude should be re-established and the power reduced again. DO NOT increase the pitch attitude without

increasing the power, since the aircraft will decelerate rapidly and may approach the critical angle of attack and stall. If there is any doubt about the approach being safely completed, it is advisable to execute an immediate go-around.

## 2. SLOW FINAL APPROACH

When the aircraft is flown at too slow an airspeed on the final approach, the pilot's judgment of the rate of sink (descent) and the height of round-out may be defective. During an excessively slow approach, the wing is operating near the critical angle of attack and, depending on the pitch attitude changes and control usage, the aircraft may stall or sink rapidly, contacting the ground with a hard impact. Whenever a slow-speed approach is noted, the pilot should apply power to accelerate the aircraft and increase the lift to reduce the sink rate, re-establish energy and to prevent a stall. This should be done while still at a high enough altitude to re-establish the correct approach airspeed and attitude.

If too slow and too low it is best to execute a go-around. Final Approach when you undershoot. Your low or slow final approach may result in the aircraft touchdown short of the desired spot. If your mistake is insignificant, you can correct it by power adding, and the pitch attitude raising, your airspeed must be 160 kmph. If your mistake is significant, you may correct it by the aircraft pulling into the level, your airspeed must be 160 kmph (Your altitude must be not less than 5-6 m- the altitude of the round-out starting). Final approach when you overshoot. Corrective actions; by the stick (elevator) forward pressure (insignificant) lower the pitch attitude and close the throttle (may be even idle) . Your speed must be 160 kmph. Descent with the throttle retarded should be completed at altitude 50 m, then you should raise the pitch attitude because during the descent with the landing flaps retracted and the throttle closed the aircraft vertical velocity is 6-7 m/sec, the descent angle is 10-12 and that makes the landing difficult. You are not recommended to make the approach more accurate by the slip because the high vertical velocity during the descent with the throttle closed is enough to correct the approach. If it is necessary, you may make your landing approach more accurate by the slip until you reach altitude 50 m (speed is not more than 160 kmph, bank is not more than 30°). You should lower the right wing (right slip) or the left wing (left slip), the aircraft will tend to turn in that direction, so, it is necessary to apply sufficient opposite rudder pressure simultaneously to keep the aircraft longitudinal axis aligned with the landing runway. If you couldn't make your landing approach move accurate and your altitude is less than 50 m, you should execute a go-around, giving the controller information of your decision.

## REJECTED LANDING (GO-AROUND)

Occasionally it is advisable for safety reasons to discontinue the landing approach and make another approach under more favourable conditions.

It is recommended to execute a go-around when your altitude is not less than 50 m, although the need to discontinue a landing may arise at any point in the landing process. The most critical go-around will usually be started when very close to the ground.

Nevertheless, it is safer to make a go-around than to touch down while drifting or while in a crab or to make a hard drop-in landing from a high round-out or bounced landing.

Regardless of the height above the ground at which it is begun, a safe go-around may be accomplished if an early decision is made and the procedure is performed properly. The earlier a dangerous situation is recognized and the sooner the landing is rejected and the go-around started, the safer the procedure will be.

When the decision is made to discontinue an approach and perform a go-around, take off power should be applied immediately and the aircraft pitch attitude changed so as to slow or stop the descent. It is necessary to hold considerable pressure on the controls to maintain straight flight and a safe climb attitude. Since the aircraft has been trimmed for the approach, the nose will tend to rise sharply and to turn to the right.

Forward stick pressure must be applied to hold the nose in a safe climbing attitude; left rudder pressure must be increased to counteract torque-factor and to keep the nose straight. While holding the aircraft in a safe climbing attitude (speed 160 kmph), the pilot should re-trim the aircraft to relieve control pressures. When you gain altitude 70-80m, you should set speed 170 kmph and retract landing flaps. To do this you should set the flaps control to "RETRACTED" position. The flaps are being retracted very smoothly, the altitude loss is not more than 10 m. Then you should retract the landing gear. It is advisable to retract the landing gear only after the initial or rough trim has been accomplished. From this point on, the procedure is identical with that for a normal climb after take off. The first turn should be carried out at altitude 50 m.

If the reason of your go-around is faulty approach, take into account your misjudgement (mistake) during the repeated approach.

## TYPICAL MISTAKES DURING FINAL APPROACH AND GO-AROUND

1. Unpunctual idling the engine (early or late) at the moment of descent starting during the base leg. That results in the turn-to-final carrying-out at the lesser or greater altitude, so, you may be short or long.
2. setting is more or less than it is required. That results in the base-to-final turn carrying-out at the lesser or greater altitude, so, you may be short or long.
3. Unpunctual carrying-out of the base-to-final turn may result in overshooting or undershooting the proper final approach path.
4. During the crosswind descent you don't compensate the drift, it may lead to the landing outside the landing runway.
5. Mistakes during your corrective actions in the course of the approach:  
applying stick back pressure to correct your undershooting, you've forgotten to open the throttle or you are late with it.  
This can lead to the low gliding speed, incipient stall is possible;  
the descent angle is preserved, the throttle is advanced, this can result in too high descent speed;  
at the end of pulling you idle the engine at first, then you make the gliding angle, as a result the aircraft loses the speed (slows down).
6. Mistakes during your corrective actions in the course of the approach by the slip:  
the bank is too steep or the vertical rudder deflection (opposite to the slip) is too insignificant, as a result the aircraft turns to the side of the bank;  
excessive stick back or forward pressure can result in non-maintenance of the assigned speed.
7. Mistakes in the course of the go-around (rejected landing)  
at first the descent angle is changed then the throttle is opened, this can lead to the speed loss;  
when advancing the throttle the aircraft tendency to turn to the right is counteracted insufficiently, as a result the aircraft turns to the right and its flight path is not parallel to the landing Tee line;  
the throttle is not advanced completely or the propeller is not set to "FINE PITCH" position, it can result in low speed which is not enough for the climb, the altitude is gained slowly;  
during the go-around the gaze from the ground is distracted (low altitude), this can lead to the wheels' blow over the ground.

## ROUND-OUT

The round-out is a slow, smooth transition from a normal approach attitude to a landing attitude. When the aircraft, in a normal descent, approaches within what appears to be about 30 m above the ground, the round-out should be started, and once started should be a continuous process until the aircraft touches down on the ground.

You should convince that the landing runway is vacant, check your speed and shift your eyes to the ground to the point of the round-out starting. Don't take away your gaze from the ground, maintain the descent angle (if your approach is accurate), control your gliding direction, absence of banks and drift. As the aircraft reaches height 5-6 m above the ground, where a timely change can be made into the proper landing attitude, back elevator pressure should be gradually applied to slowly increase the pitch attitude and angle of attack. This will cause the aircraft nose to gradually rise toward the desired landing attitude.

The height of landing attitude making must be 0,75-1,0 m. Simultaneously with the round-out starting you should close the throttle so that at this altitude it should be closed completely. The faster the ground is approaching, the more vigorous stick applying must be.

In the course of the round-out your attention should be fixed on the determination of the aircraft height above the ground and the distance to the ground. Your glance direction must be for 20-25 to the left from the aircraft longitudinal axis and 25-30 m ahead.

During the round-out one shouldn't follow the ground with your eyes (ground, runway under the aircraft), your glance should rove over the ground, trying to define the distance to the ground precisely.

At the same time you should see the whole ground surface, don't gaze into any separate point on the ground surface.

Attention distribution in the course of the round-out:

- to the height above the ground determination and the aircraft vertical velocity;
- to the gradual throttle closing;



to the banks and drift discovery;  
to directional control of the aircraft path.

The rate at which the round-out is executed depends on the aircraft height above the ground, the rate of descent and the pitch attitude. A round-out started excessively high must be executed more slowly than one from a lower height to allow the aircraft to descend to the ground while the proper landing attitude is being established.

Once the actual process of rounding out is started, the elevator control (stick) should not be pushed forward. If too much back pressure has been exerted, this pressure should be either slightly relaxed or held constant, depending on the degree of the error. In some cases it may be necessary to advance the throttle slightly to prevent an excessive rate of sink or a stall, all of which would result in a hard drop-in landing. It is recommended to keep one hand on the throttle throughout the approach and landing, because sudden and unexpected hazardous situation can require an immediate application of power. When you reach the height above the ground approximately 0,75-1,0 m you should slow down preserving the aircraft landing attitude. Take into consideration, that the speed reduces very quickly (if the throttle is closed), so you have a short time.

In the course of the round-out you shouldn't bend your head on one side because in this case you get a wrong idea of the aircraft position in respect to the ground. This can result in involuntary bank making and direction loss. You should set straight with your head turned slightly to the left. You should remember that because of the wing transverse-V wrong impression of the right bank presence arises. If you don't take it into consideration this can cause the pilot's wish to counteract the non-existing right bank and in fact it can be the reason of the left bank making. The appearing banks should be eliminated with the help of ailerons.

to the accurate and coordinated aileron, elevator and rudder operation, to the speed maintenance and to the accurate approach. It is very dangerous to apply excessive back elevator (control stick) pressure while making turn, because it can result in the speed loss and stall.

## 18. TOUCHDOWN

The touchdown is the gentle settling of the aircraft onto the landing surface. The round-out and touchdown should be made with the engine idling and the aircraft at minimum controllable airspeed, so that the aircraft will touch down on the main gear at approximately stalling speed and from the height 0,15-0,25 m above the ground.

The landing speed is 115-120 kmph.

As the aircraft settles, the proper landing attitude must be attained by application of back elevator pressure. During the after landing roll you should keep the aircraft in the landing attitude until it decelerates and lowers the nose wheel. YAK-52 is a nose wheel-type aircraft should contact the ground in a tail-low attitude, with the main wheels touching down first so that little or no weight is on the nose wheel.

It is extremely important that the touchdown should occur with the aircraft longitudinal axis exactly parallel to the direction in which the aircraft is moving along the runway. Failure to accomplish this not only imposes severe side loads on the landing gear but imparts ground looping tendencies. To avoid these side stresses, the pilot must never allow the airplane to touch down while in a crab or while drifting.

If the aircraft settles on the three wheels, you should apply the back stick pressure very smoothly during the after landing roll to diminish the load on the nose wheel. You are not allowed to part the nose wheel from the ground. If you are carrying out the landing from the altitude more than 0,25 m, the aircraft can strike the nose wheel over the ground. To avoid this rough touch of the nose wheel over the ground you are not recommended to push the stick forward.

### CROSSWIND APPROACH AND LANDING

The same basic principles and factors involved in a normal approach and landing apply to a crosswind approach and landing. But there are some additional techniques required for correcting for wind drift. Crosswind landings are a little more difficult to perform than are crosswind take offs, mainly due to different problems involved in maintaining accurate control of the aircraft while its speed is decreasing rather than increasing as on take off.

The wind-low method of accomplishing a crosswind approach and landing will compensate for a crosswind from any angle. To use this method, the pilot aligns the aircraft heading with the centre line of the runway, notes the rate and direction of drift, then promptly applies drift correction by lowering the upwind wing.

The amount the wing must be lowered depends on the rate of drift. When the wing is lowered, the aircraft will tend to turn in that direction. It is necessary to apply sufficient opposite rudder pressure to prevent the turn and keep the aircraft longitudinal axis aligned with the runway. In other words, the drift is controlled with aileron, and the heading with rudder. The aircraft will now be side slipping into the wind just enough that both the resultant flight path and the ground track are aligned with the runway. During the round-out the airspeed decreases, the flight controls gradually become less effective, so it is necessary to gradually increase the deflection of the rudder and ailerons to maintain the proper amount of drift correction.

Do not level the wings; keep the upwind wing down throughout the round-out. If the wings are levelled, the aircraft will begin drifting and the touchdown will occur while drifting. Just before the touchdown press the upwind rudder pedal so that you could land on two main wheels with minimum side load on the wheels.

During the after-landing roll special attention must be given to maintaining directional control by use of rudder or nose wheel steering, while keeping the upwind wing from rising by use of aileron. The aircraft YAK-52 is steady during the after-landing roll.

## TYPICAL MISTAKES DURING LANDING. REASONS AND CORRECTIVE ACTIONS

### 1. HIGH ROUND-OUT

Sometimes when the aircraft appears to temporarily stop moving downward, the round-out has been made too rapidly and the aircraft flying level too high above the runway. Continuing the round-out would further reduce the airspeed, resulting in an increase in angle of attack to the critical angle and this would result in the aircraft stalling and dropping hard onto the runway.

The reasons of the high round-out can be following:

- the lack of skill of the pilot to determine exactly the height above the ground;
- incorrect glance direction in the course of "the landing (too close to the wing or fuselage);
- aspiration for the aircraft landing as early as possible, without altitude and speed consideration (landing approach when you overshoot);
- excessive carefulness (when the pilot is not sure in proper definition of the aircraft height above the ground).

#### CORRECTIVE ACTIONS:

To prevent the hazardous situation as a result of the high round-out, the pitch attitude should be held constant until the aircraft decelerates enough to start descending again. Then the round-out can be continued to establish the proper landing attitude. The aircraft height above the ground should be 0,75-1,0 m. If you've finished the round-out at height 1,5-2,0 m above the ground you should lower the aircraft by insignificant forward stick pressure. When your height above the ground is 0,75 m you should establish the proper landing attitude and perform the touchdown on two main wheels. You must remember that the aircraft after the high round-out when the throttle is closed completely approaches the ground with the increased vertical velocity, that's why you should be very careful with the stick movements.

### 2. LATE OR RAPID ROUND-OUT

Starting the round-out too late or pulling the stick back too rapidly to prevent the aircraft from touching down prematurely can impose a heavy load factor on the wing and cause an accelerated stall. Suddenly increasing the angle of attack and stalling the aircraft during the round-out is a dangerous situation since it may cause the aircraft to land extremely hard on the main landing gear and turn bounce back into the air.

Recovery from this situation requires prompt and positive application of power prior to occurrence of the stall. This may be followed by a normal landing if sufficient runway is available otherwise the pilot should execute a go-around immediately.

### 3. FLOATING DURING ROUND-OUT

If the airspeed on final approach is excessive, it will usually result in the aircraft "floating".

The reasons of the aircraft floating during the round-out can be the following:

- excessive gliding speed (usually when you overshoot);
- the throttle is not closed completely;
- you are late with your glance moving on the ground;
- incorrect glance direction (too close to the front part of the wing) ;
- glance distraction from the ground;
- late round-out, result of rapid stick back pulling.

Any time the aircraft floats, judgment of speed, height and rate of sink must be especially seen. The slightest error in judgment and timing will result in either ballooning or bouncing. The recovery from floating will depend on the amount of runway remaining. If the pilot misjudges the rate of sink during a landing and thinks the aircraft is descending faster than it should, there is a tendency to increase the pitch attitude and/ angle of attack

too rapidly. This not only stops the descent, but actually starts the aircraft climbing. This climbing during the round out is known as "ballooning".

Ballooning can be dangerous because the height above the ground is increasing and the aircraft may be rapidly approaching a stalled condition. The altitude gained in each instance will depend on the airspeed or the rapidity with which the pitch attitude is increased. When ballooning is slight (not more than 1,5 m), a constant landing attitude should be held and the aircraft allowed to decelerate gradually and settle onto the runway. When ballooning is more severe (1,5-2,0 m), you should apply slight forward stick pressure to stop the climbing, then, by smooth back stick pressure establish the landing attitude and perform the landing. You should remember that after ballooning the aircraft approaches the ground with increased vertical velocity, be back stick pressure should be applied more rapidly to have enough time to establish the landing attitude up to height 0,15-0,25 m above the ground (you should check the absence of banks). When ballooning is excessive (more than 2m), it is best to execute a go-around immediately.

#### 4. BOUNCING DURING TOUCHDOWN

When the aircraft contacts the ground with a sharp impact as the result of an improper attitude or an excessive rate of sink, it tends to "bounce" back into the air. If a bounce occurs when the aircraft makes contact with the ground before the proper touchdown attitude is attained, it is almost invariably accompanied by the application of excessive back elevator pressure. The corrective action for a bounce is the same as for ballooning and similarly depends on its severity. When it is very slight and there is no extreme change in the aircraft pitch attitude, you can smoothly adjust the pitch to the proper touchdown attitude. When a bounce is severe, the safest procedure is to execute a go-around immediately. Full power should be applied while simultaneously maintaining directional control. The go-around procedure should be continued even though the aircraft may descend and another bounce may be encountered. It would be extremely foolish to attempt a landing from a bad bounce since airspeed diminishes very rapidly in the nose-high attitude and a stall may occur before a subsequent touchdown could be made.

## 19. AFTERLANDING ROLL

The landing process must never be considered complete until the aircraft decelerates to the normal taxi speed during the landing roll or has been brought to a complete stop when clear of the landing area. The pilot must be alert for directional control difficulties immediately upon and after touchdown due to the ground friction on the wheels.

Loss of directional control may lead to an aggravated, uncontrolled turn on the ground. Rudder performs the same function on the ground as it does in the air- it controls the yawing of the aircraft. The effectiveness of the rudder is dependent on the airflow which depends on the speed of the aircraft. As the speed decreases and the nose wheel has been lowered to the ground, you may use the brakes to reduce speed and as an aid in directional control. To use brakes for the ground speed decrease you should apply slight pressures on the braking lever on the stick, rudder pedals should be held in neutral position. During the ground roll the aircraft direction of movement may be changed by carefully applying pressure on one rudder pressure and short pressures on the braking lever on the stick. After a complete stop you should look around: if there is another aircraft landing, open the throttle and clear the landing runway. Retract the landing flaps while taxiing.

## 20. TAXIING AFTER LANDING

After the aircraft has been slowed sufficiently and has been turned onto a taxiway or clear of the landing area, it should be brought to its parking place. If you see another aircraft taxiing from the landing runway, you should stop and make way for it. After your aircraft should be brought to its place, you should shutdown the engine.

## 21. ENGINE SHUTDOWN

1. Set the parking brakes ON;
2. Set the throttle to IDLE;
3. Turn the radio station, radio compass, cockpit communication system , attitude indicator OFF;
4. Cool down the engine if necessary. Cylinder head temperature should be 140..160°C. One should avoid the prolonged engine run at low RPM. ;
5. Burn through the sparking plugs (RPM up to 65..68% for 20 seconds), idle the engine;
6. Turn magneto switch OFF (0 position);
7. Turn all other switches OFF.

*Note: It is forbidden to perform engine shutdown after high power setting*

## 22. CLIMBING FLIGHT

Climb power setting

Airspeed- 170 kmph.

Cylinder's head temperature- 140-190°C. (up to 220°C).

Engine inlet oil temperature- 50-60°C

Oil pressure- 4-6 kg/cm<sup>2</sup>,

Fuel pressure- 0,2-0,5 kg/cm<sup>2</sup>

If you have different indicator readings (exceeding the desired readings), level off the aircraft, increase the airspeed and set the level flight power setting. If cylinder head temperature or oil temperature remains high, you should inform the controller and perform the landing.

Up to the height above the grounds

0- 500 m- airspeed 170 kmph 500- 2000 m- airspeed 160 kmph 2000- 4000 m- airspeed 150 kmph

## 23. STRAIGHT AND LEVEL FLIGHT

Airspeed range in level flight is 130 kmph- 300 kmph (maximum). During the pattern flight airspeed 180 kmph is recommended.