

The Airbus safety magazine

January 2016

#21

Safety first



Safety first

Safety first, #21 January, 2016. Safety first is published by Airbus S.A.S. - 1, rond point Maurice Bellonte - 31707 Blagnac Cedex/France. Publisher: Yannick Malinge, Chief Product Safety Officer, Editor: Corinne Bieder, Director Product Safety Strategy & Communication. Concept Design by Airbus Multi Media Support 20152712. Reference: GS 420.0045 Issue 21. Photos by Airbus, A. Doumenjou, H. Goussé, P. Pigeyre, A. Tchaikovski, Lindner Fotografie.

This brochure is printed on Stucco.

This paper is produced in factories that are accredited EMAS and certified ISO 9001-14001, PEFC and FSC CoC. It is produced using pulp that has been whitened without either chlorine or acid. The paper is entirely recyclable and is produced from trees grown in sustainable forest resources.

The printing inks use organic pigments or minerals. There is no use of basic dyes or dangerous metals from the cadmium, lead, mercury or hexavalent chromium group.

© Airbus S.A.S. 2016 – All rights reserved. Proprietary documents.

By taking delivery of this Brochure (hereafter "Brochure"), you accept on behalf of your company to comply with the following guidelines:

» No other intellectual property rights are granted by the delivery of this Brochure than the right to read it, for the sole purpose of information.

» This Brochure and its content shall not be modified and its illustrations and photos shall not be reproduced without prior written consent of Airbus.

» This Brochure and the materials it contains shall not, in whole or in part, be sold, rented, or licensed to any third party subject to payment.

This Brochure contains sensitive information that is correct at the time of going to press.

This information involves a number of factors that could change over time, effecting the true public representation. Airbus assumes no obligation to update any information contained in this document or with respect to the information described herein.

Airbus S.A.S. shall assume no liability for any damage in connection with the use of this Brochure and of the materials it contains, even if Airbus S.A.S. has been advised of the likelihood of such damages.

The Airbus magazine contributing to the enhancement of the safety of aircraft operations by increasing knowledge and communication on safety related topics.

Safety first is published by the Product Safety department. It is a source of specialist safety information for the use of airlines who fly and maintain Airbus aircraft. It is also distributed to other selected organizations and is available on tablets.

Material for publication is obtained from multiple sources and includes selected information from the Airbus Flight Safety Confidential Reporting System, incident and accident investigation reports, system tests and flight tests. Material is also obtained from sources within the airline industry, studies and reports from government agencies and other aviation sources.

All articles in Safety first are presented for information only and are not intended to replace ICAO guidelines, standards or recommended practices, operator-mandated requirements or technical orders. The contents do not supersede any requirements mandated by the State of Registry of the Operator's aircraft or supersede or amend any Airbus type-specific AFM, AMM, FCOM, MMEL documentation or any other approved documentation.

Articles may be reprinted without permission, except where copyright source is indicated, but with acknowledgement to Airbus. Where Airbus is not the author, the contents of the article do not necessarily reflect the views of Airbus, neither do they indicate Company policy.

Contributions, comment and feedback are welcome. Enquiries related to this publication should be addressed to:

Airbus
Product Safety department (GS)
1, rond point Maurice Bellonte
31707 Blagnac Cedex - France
Fax: +33(0)5 61 93 44 29

safetycommunication@airbus.com



editorial



YANNICK MALINGE
SVP & Chief
Product Safety Officer

At this time of the year, discussions will start on the safety of the year that just ended. Everybody will set the objective to do better than last year. And this is good. This very mindset is what allowed aviation for reaching today's safety level.

When contemplating the future, it is often valuable to look at the past. We ourselves went through this exercise and revisited how the aviation industry got there. We believe that this historical overview can be of interest to others. This is why we want to share it not only with the aviation community but also with the public. Indeed, aviation safety is relevant to everyone, whether as a passenger, crew-member, potential traveller, relative of someone flying, or citizen.

Safety can never be taken for granted. Aviation safety has a fascinating history of which we all together need to write the next pages.

I hope you will enjoy this video and find it inspiring to further enhance safety.

May I take this opportunity to wish you and your relatives a very happy and safe New Year.



The video is available on Airbus' YouTube channel (www.youtube.com/airbus), Twitter account (www.twitter.com/airbus) and Facebook page (www.facebook.com/airbus).

22nd Flight Safety Conference

Bangkok, 21-24 March 2016

SAVE THE DATE NEWS

22nd FLIGHT SAFETY CONFERENCE – 2016

Another year has nearly passed since our last Flight Safety Conference in Paris. All the Airbus people who were present enjoyed very much the opportunity to network with our customers and to share ideas and news. This was also confirmed by all the feedback we received from airlines delegates who valued this great opportunity for sharing safety information.

We are pleased to announce that the 22nd Flight Safety Conference will take place in Bangkok, Thailand, from the 21st to the 24th of March 2016.

The Flight Safety Conference provides an excellent forum for the exchange of information between Airbus and its customers.

To ensure that we can have an open dialogue to promote flight safety across the fleet, we are unable to accept outside parties.

The formal invitations with information regarding registration and logistics, as well as the preliminary agenda have been sent to our customers in January 2016.

For any information regarding invitations, please contact Mrs. Nuria Soler at nuria.soler@airbus.com

This year, the two main themes will be non-precision approaches and the evolving situation regarding skills, knowledge and experience. Our conference "journey" through these topics will take us along the route of examining related incidents and accidents, how product design and operational procedures have accommodated these aspects and what best practice looks like from an airline perspective. As usual, there will be much to share and many opportunities to learn from each other.

As always, we welcome presentations from our operators. You can participate as a speaker and share your ideas and experience for improving aviation safety.

If you have something you believe will benefit other operators and/or Airbus and if you are interested in being a speaker, please provide us with a brief abstract and a bio or resume at nuria.soler@airbus.com



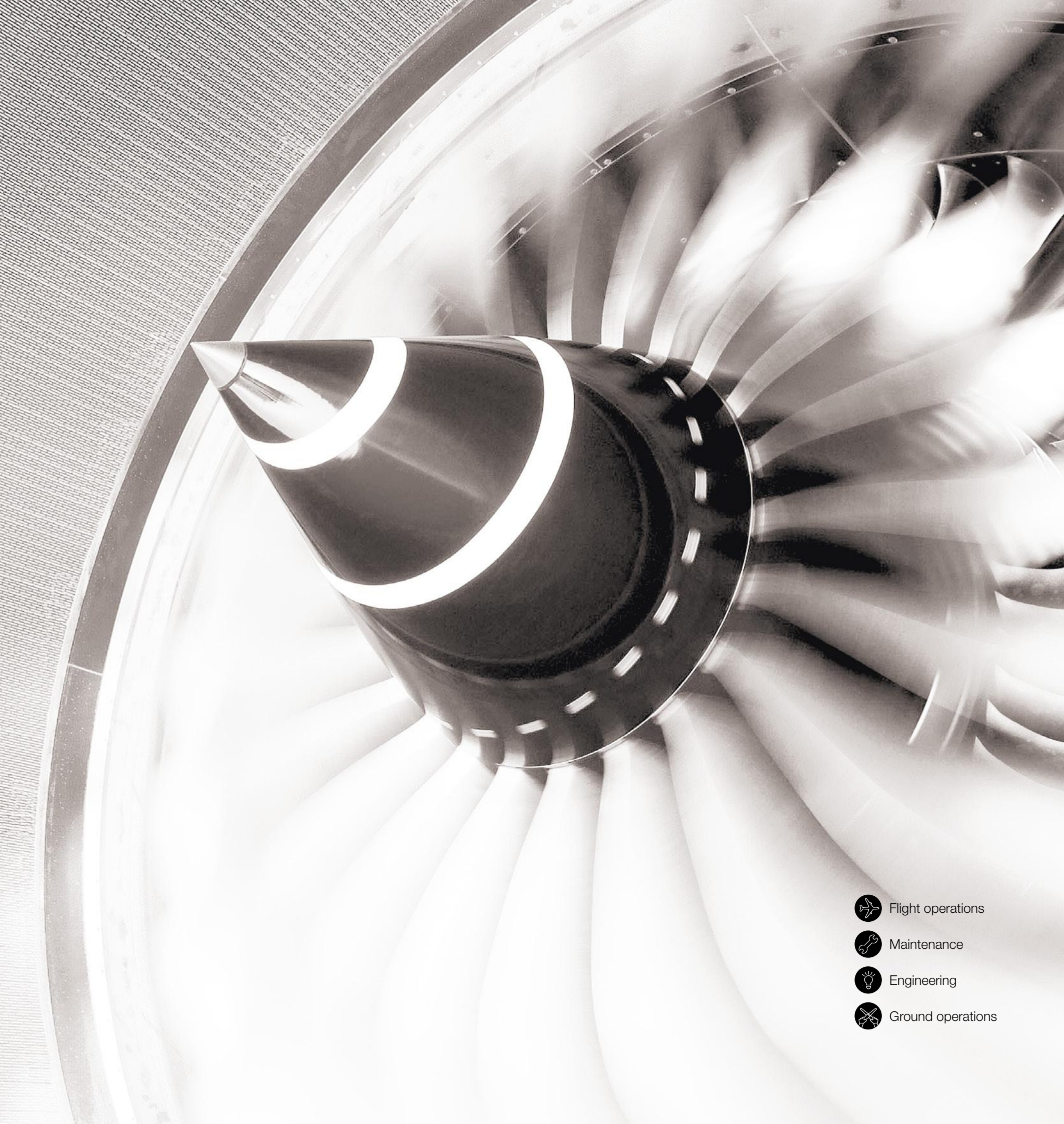

Safety first #21

-  Flight operations
-  Maintenance
-  Engineering
-  Ground operations

PROCEDURES



P06 
Control your speed... in cruise

OPERATIONS

P22    
Lithium batteries: safe to fly?

P42 
Wake Vortices

AIRCRAFT

P52   
A320 Family Aircraft configuration



Control your speed... in cruise

Third article in the “Control your speed” series started in issue #18 of this magazine, our aircraft is now flying in clean configuration, travelling in cruise. The main objective is to manage threats to the airspeed and avoid speed excursions.



LORRAINE DE BAUDUS
Flight Operations Standards and Safety management



PHILIPPE CASTAIGNS
Experimental Test Pilot

MANAGING YOUR CRUISE: UNDERSTANDING SPEEDS

Speed in cruise is often driven by performances and fuel burn considerations; however, Air Traffic or weather considerations sometimes intervene and require modifications to the optimum cruise profile. Whatever the flight crew’s decisions to best optimize their flight, one needs to be constantly aware of the applicable limits and maneuvering speeds. To safely manage the cruise phase within the aircraft certified flight envelope, some characteristic speeds are useful references for flight crews to monitor the aircraft’s actual speed. What speeds exactly should be monitored? What do these speeds mean and what happens if they are ignored?

Many speeds are used to certify and fly an aircraft operationally. For every flight, the applicable characteristic speeds are computed automatically by the aircraft Auto Flight Systems (Flight Management System (FMS), Flight Guidance (FG) and Flight Envelope (FE)) and displayed on the PFD airspeed scale. They are extremely useful as target maneuvering and limit

reference speeds to safely guide the pilots navigation decisions through the cruise phase.

Our objective is to highlight the design and operational considerations underlying all recommendations Airbus has issued to flight crews regarding the monitoring of these speeds in cruise.

Technically, cruising consists of heading changes and aircraft systems monitoring (fuel in particular), at a relatively constant airspeed and altitude. It ends as the aircraft approaches the destination where the descent commences in preparation for landing.

Speed monitoring and control are crucial during this phase of flight to guarantee that the aircraft flies within its certified flight envelope at all times, and any threats to the airspeed can be properly managed.

This article will not immerse readers into the challenge of optimizing the aircraft performances in cruise, but it will aim at shedding more light on the existing threats to the airspeed during cruise, as well as good practices to best manage them. While planning their cruise to make the right speed and flight level choices, the flight crew needs to remain vigilant to speed excursions, and be able to recover if needed.

NOTE

System descriptions and information included in this article are mainly referring to fly-by-wire aircraft. However, the recommendations for speed management remain applicable to all aircraft.

Maneuvering speed

Green Dot was presented already in the previous article dedicated to the climb phase. Nevertheless, it is important to have this speed in mind during the cruise phase as well, because it is a clearly visible reference speed on the PFD airspeed scale.

We will see hereafter why pilots should not routinely fly slower than GD in cruise.

For this reason, a recap of GD definition is provided hereafter, as well as the consequences of flying slower than GD in cruise.

Green Dot (GD): best lift-to-drag ratio speed

» Definition

GD speed is the engine-out operating speed in clean configuration. It corresponds to the speed that allows the highest climb gradient with one engine inoperative in clean configuration. In all cases (all engines operative), the GD speed gives an estimate of the speed for best lift-to-drag ratio.

It is represented by a green dot on the PFD speed scale and displayed only when the slats / flaps control lever is in the '0' (CLEAN) position and landing gears are not compressed (**fig.1**).

» How is GD determined?

GD speed is computed by the Auto Flight Systems (AFS) and is based on the aircraft weight (thanks to the Zero Fuel Weight (ZFW) inserted in the FMS during flight preparation). The GD formula has been set up so that the resulting airspeed provides the best lift-to-drag ratio for a given altitude, Mach number and aircraft weight, in clean configuration with one engine out.

In cruise:

- Above GD, the drag and thrust required to maintain speed increase with the speed
- Below GD, the drag and thrust required to maintain speed increase with speed decrease (second regime) (**fig.2**).

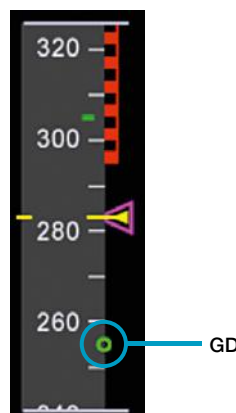

(fig.1) GD on the PFD speed scale

(fig.2) Thrust curves and speed polar

Region of reversed command (second regime)

- Given:
- altitude
 - temperature
 - weight
 - thrust

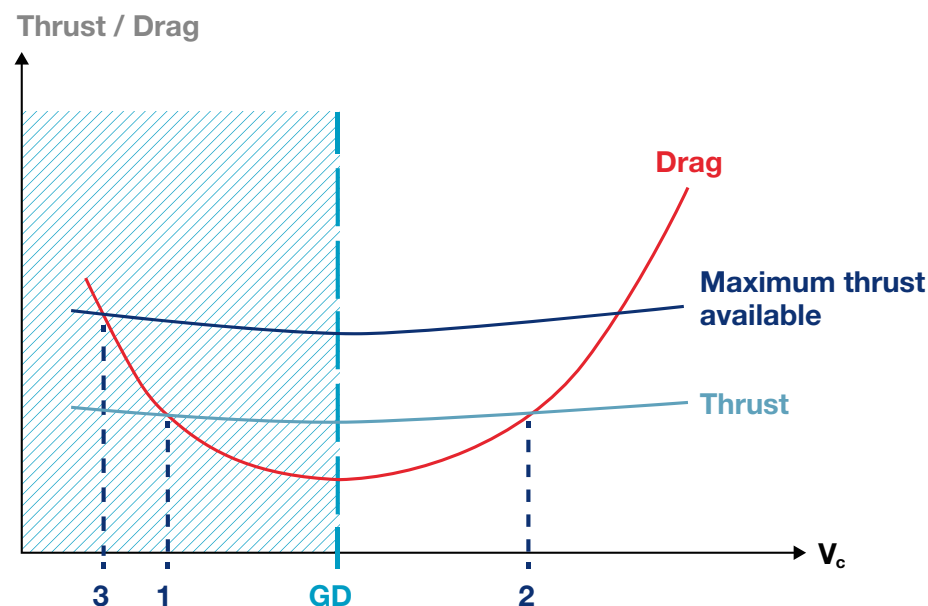

FIRST OR SECOND REGIME?

At a given altitude, temperature, weight and thrust, figure 2 shows 2 points of equilibrium where the thrust precisely compensates for the drag (thrust = drag) and stabilized level flight is possible: point 1 (where V_c is lower than GD) and point 2 (where V_c is higher than GD). Let's have a closer look at the aircraft behaviour if the speed is moving away from these speeds:

- Point 2 is a stable equilibrium: in cruise, when the aircraft flies at this point 2, the airspeed is stabilized. Small variations of airspeed will naturally be compensated for and the aircraft will return to point 2. At point 2, the aircraft flies in the **first regime**.
 - If a disturbance increases the aircraft's speed above point 2, then the drag increases. Consequently, the aircraft will decelerate back to the equilibrium point 2.
 - If a disturbance reduces the aircraft's speed below point 2, then the drag decreases. This generates acceleration and the aircraft's speed will naturally increase back to the equilibrium point 2.
- Point 1 is an unstable equilibrium: at this point, the aircraft flies in the **second regime**.
 - If a disturbance increases the aircraft's speed above point 1, the drag reduces; therefore the aircraft will continue to accelerate until point 2.
 - If a disturbance reduces the aircraft's speed below point 1, then the drag becomes increasingly higher. If no action is taken, the aircraft will be naturally induced into a continuous deceleration. To stop the deceleration and be able to accelerate again, two scenarios are possible:
 - » When speed reduces below point 1 and remains higher than point 3: if maximum thrust available is applied, then the aircraft can accelerate.
 - » When speed reduces below point 3: there is no thrust margin available to accelerate while maintaining a stabilized level flight. Then the only way to stop the deceleration is to lose altitude in order to accelerate beyond point 3.

To sum up:

- Faster than GD, the aircraft flies in the first regime: it is stable with regards to speed.
- Slower than GD, the aircraft flies in the second regime: it is unstable with regards to speed.

» What are the operational implications of flying below GD?

Point 3 is not displayed on the PFD airspeed scale. Only GD is shown.

point 3 and eventually in a continuous deceleration.

The higher the aircraft, the lower the maximum thrust available. This means that at high altitude, close to REC MAX (RECOMMENDED MAXIMUM altitude), point 3 and GD are close to each other because the thrust margin is small. Therefore flying below GD in level flight could easily drive the aircraft slower than

Consequently, in clean configuration in cruise, the crew should not fly below GD.

Exceptionally, if flight slightly below GD is required for some reason, then vigilant monitoring is necessary to ensure that further uncommanded speed reductions are immediately checked and recovered from.

GD IN A NUTSHELL
Do not fly below GD in cruise.

HOW IS THE REC MAX (RECOMMENDED MAXIMUM ALTITUDE) COMPUTED?

Looking more closely at the exact conditions limiting the altitude where a subsonic aircraft can safely fly at, these can range from aerodynamic limitations to propulsion and certification limitations.

REC MAX is the upper cruise limit:

REC MAX = Min [Service ceiling; Aerodynamic ceiling; Max certified ceiling]

The schematic below applies to a heavy aircraft, which has a ceiling lower than the maximum certified one.

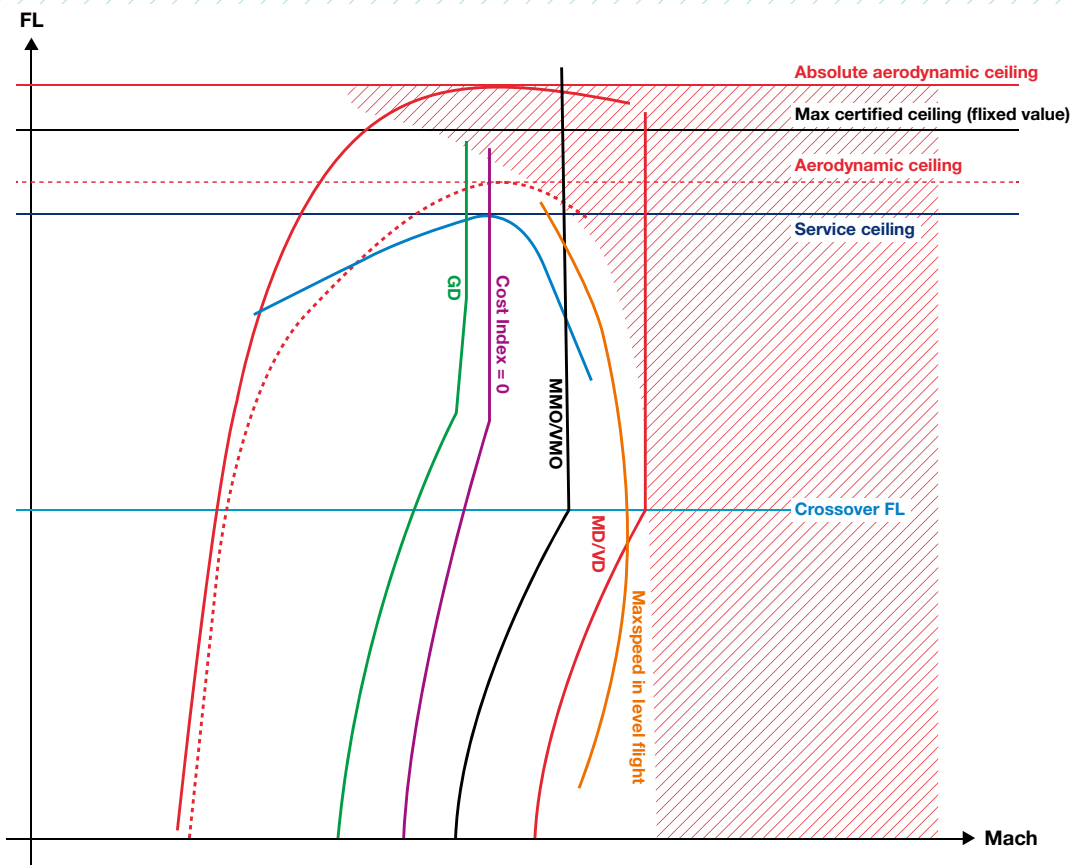

- Stall limit (V_{S1g}): this speed curve lowers with a weight increase.
- - - This curve provides a safety maneuver margin against the Stall limit curve. At low Mach, it starts at $1.23 \times V_{S1g}$. At higher Mach, it corresponds to buffet onset of 1.3g (corresponding to 40° of bank angle in level flight). This curve lowers with weight increase.
- - - Aerodynamic ceiling (increases with weight decrease).
- Service curve, corresponding to the propulsion capacity of the aircraft's engines to maintain + 300ft/minute at a constant Mach. This curve increases with weight decrease and with static temperature decrease.
- Service ceiling (increases with weight decrease or temperature decrease).
- Maximum speed in level flight (in stable weather conditions with maximum thrust available in use)
- /// Inaccessible domain (drag exceeds thrust), except if the aircraft is being subject to extreme weather conditions or enters a steep dive with maximum thrust.

On Airbus aircraft, the REC MAX is always limited by the service ceiling or the certified ceiling; with the exception of A319 CJ aircraft and some versions of A340-500/600 aircraft at heavy weights. The following graph gives an illustrative example of the above theoretical curves for an A320. This graph is used by the FMS to determine REC MAX.

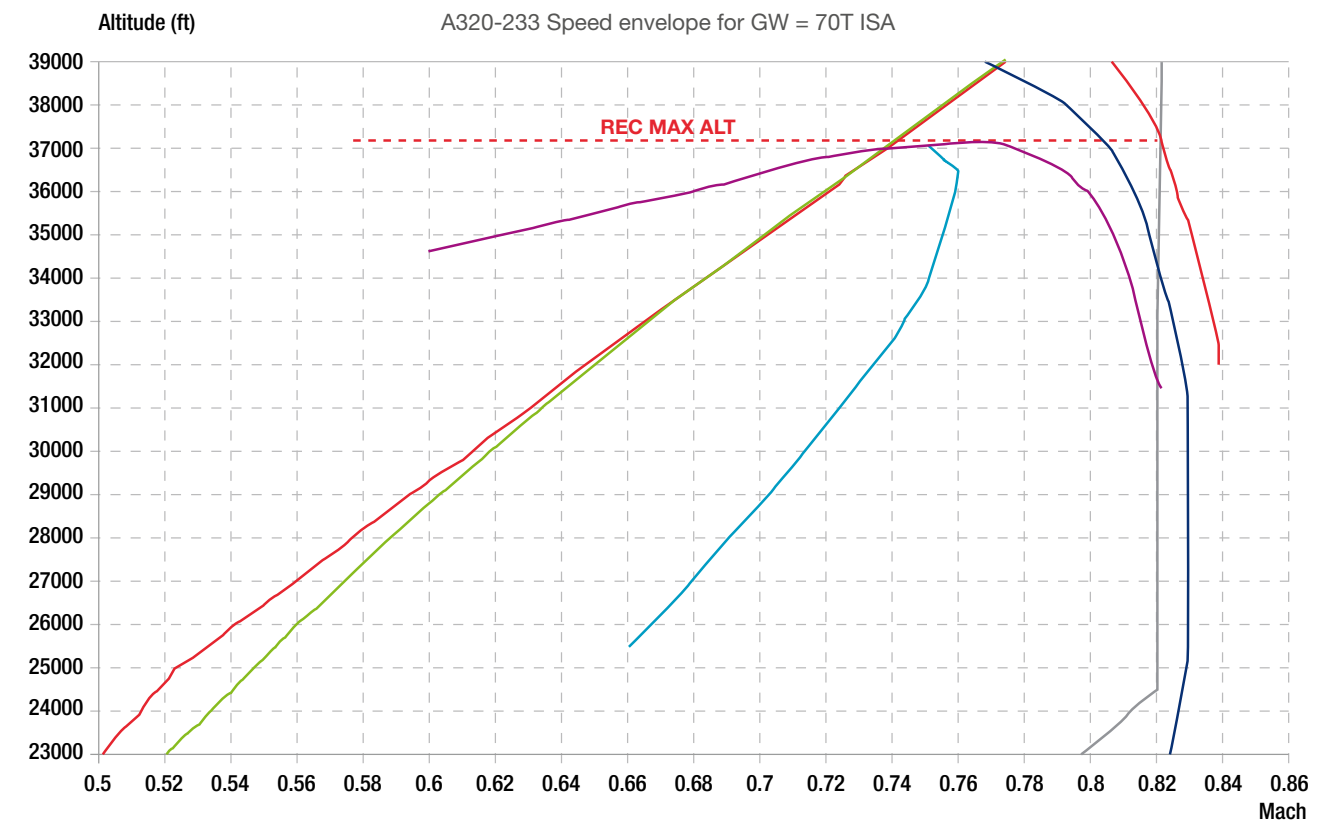

- Green Dot
- Buffet (1,3g)
- $V_z 300$ ft/min
- V_{MO}/M_{MO}
- V_{MAX} level at Max CLB
- Econ speed CI = 0

CI = 0 (Cost Index 0) is the point that gives the maximum rate of climb at a steady Mach.

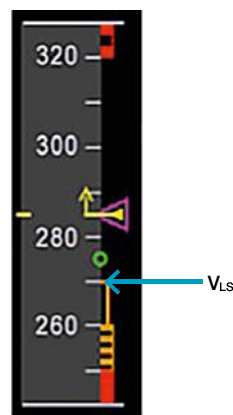

(fig.3) V_{LS} on the PFD speed scale

“GD and V_{LS} both depend on the aircraft weight, therefore these speeds will be wrong if the ZFW entered in the FMS is wrong.”

Limit speeds

For a given weight, each aircraft has a minimum selectable speed (V_{LS}) and maximum speed (V_{MAX}) at a particular altitude. At the cruise altitude, there

needs to be a safe margin in relation to these lowest and highest speeds, before the flight envelope protections activate.

V_{LS}: Lowest Selectable speed

» Definition

V_{LS} is the lowest selectable speed with A/THR engaged. Even if the target speed is below V_{LS}, the A/THR will continue to target V_{LS}.

V_{LS} is indicated by the top of the amber line on the PFD speed scale (fig.3).

» How is V_{LS} determined?

V_{LS} is a characteristic speed computed by the AFS as a function of the aircraft weight (dependent on the Zero Fuel

Weight (ZFW) inserted in the FMS during flight preparation).

$$V_{LS} = 1.23 V_{S1g} \text{ when in clean configuration}$$

Where:

V_{S1g} is the stall speed demonstrated by flight tests.

Note: the 1.23 factor is applicable to fly-by-wire aircraft (1.3 for the others).

This formula means that V_{LS} is higher since speed brakes extension when the speed brakes are extended,

since speed brakes extension increases V_{S1g}.

» What are the operational implications of not respecting V_{LS}?

Deliberately flying below V_{LS} could either lead to an activation of the Angle-Of-Attack protection on a protected

aircraft, or expose the aircraft to a stall if it is not protected, i.e. flying in a degraded law.

V_{LS} IN A NUTSHELL.

V_{LS} is the slowest speed the AFS lets you fly in normal law.

V_{MO}/M_{MO}: Maximum Operating speed/Mach number

» Definition

In cruise, in clean configuration, V_{MO}/M_{MO} is the higher limit of the aircraft speed envelope.

It is indicated by the lower end of the red and black strip along the PFD speed scale (fig.4).

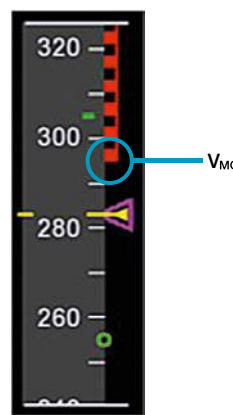

(fig.4) V_{MO} on the PFD speed scale

THE CROSSOVER ALTITUDE

Aircraft normally fly at an optimal IAS until they reach their optimal climb/cruise Mach. This transition between airspeed and Mach occurs at a point called the “crossover altitude” (usually between FL250 and FL300 depending on the aircraft type).

When the aircraft climbs to the crossover altitude at a constant IAS, Mach increases. The opposite happens when in descent to the crossover altitude, at a constant Mach. Then the IAS increases.

At altitudes above the crossover altitude, pilots will fly a Mach number instead of an IAS because it then becomes the most meaningful parameter.

Different phenomena exist according to the speed or Mach the aircraft flies at. The aerodynamic world can therefore be split into two areas: low and high Mach numbers.

- At high Mach number, when accelerating beyond M_{MO}, slight vibrations may appear. These are vibrations due to unsteady early

onset shock waves developing on the wings upper surface. These shock waves significantly worsen the drag and can alter the aircraft’s controllability. But this phenomenon has nothing to do with buffet announcing lack of lift to come or an approaching stall. Airbus airplanes operated up to VD/MD are not exposed to the so-called high speed buffet.

- At high Indicated AirSpeed (IAS), the main threat to the aircraft structural integrity lies in the dynamic pressure exerted by air on the structure. Aircraft controllability remains optimum as long as the Mach number is not too high.

In practice, the aircraft is designed to be safe up to Mach/speeds well above V_{MO}/M_{MO}. Indeed, according to certification requirements the aircraft must be safe to fly up to the design limit speed/Mach number VD/MD. In other words, up to VD/MD, the aircraft remains controllable and free of any flutter.

» How is V_{MO}/M_{MO} determined?

V_{MO}/M_{MO} is established with regards to the aircraft’s structural limits and it provides a margin to the design limit speed/Mach number VD/MD. VD/MD must be sufficiently above V_{MO}/M_{MO} to make it highly improbable that VD/MD will be inadvertently exceeded in commercial operations. Several certification criteria exist. As a result,

on Airbus aircraft, MD is usually equal to M_{MO} + 0.07 and VD approximately equal to V_{MO} + 35 kt.

The applicable V_{MO}/M_{MO} are indicated in each Aircraft Flight Manual. For example, V_{MO}/M_{MO} and VD/MD are given in the following table.

Aircraft type	V _{MO} (kt)	M _{MO}	VD (kt)	MD
A350	340	0.89	375	0.96
A380	340	0.89	375	0.96
A330/A340	330	0.86	365	0.93
A320 Family	350	0.82	381	0.89
A300-600	335	0.82	395	0.89
A310	360	0.84	420	0.90

“ At low altitudes, the threat of exceeding V_{MO} by a significant amount is real and it can dramatically affect the integrity of the aircraft’s structure. ”

These concepts involve understanding the maximum structural speed and Mach of the aircraft **VD/MD**.

VD is a Calibrated Air Speed (CAS). During test flights, VD/MD are reached by test pilots with the objective to demonstrate that the aircraft structural integrity is not put at stake at these speeds, and that the aircraft remains safely recoverable at all times. The article “High-altitude manual flying” that was published in the 20th issue of this magazine provides a good explanation

of the maneuver performed by test pilots to determine these speed and Mach.

- Key points to remember are:
- Reaching VD is much easier than reaching MD,
 - At high altitude, reaching the aircraft’s structural limit is almost impossible,
 - At lower altitudes (i.e. below the crossover altitude), reaching VD is possible because the available thrust is higher, and drag due to Mach is lower.

» **What are the operational implications of not respecting V_{MO}/M_{MO} ?**

The JAR / FAR 25 rule dictates that V_{MO} or M_{MO} may not be deliberately exceeded in any regime of flight. The parameter V_{MO}/M_{MO} basically sets upper boundaries to the aircraft speed envelope.

- Crews should keep in mind that
- At high altitude, whilst it is important to always respect MMO, a slight and temporary Mach increase above that value will not lead the aircraft into an immediate hasardous situation.

- At lower altitudes, exceeding V_{MO} by a significant amount is a real threat and can dramatically affect the integrity of the aircraft’s structure.

Although intentional V_{MO}/M_{MO} exceedance cases are rare, this limit speed can typically be overshot when the aircraft is subject to unusual wind and/or temperature gradient. Prevention is therefore essential.

V_{MO}/M_{MO} IN A NUTSHELL
 V_{MO}/M_{MO} is the “never to exceed” speed.

Flight envelope protection speeds: $V_{\alpha\text{PROT}}$ and $V_{\alpha\text{MAX}}$

» **Definition**

$V_{\alpha\text{PROT}}$ is the speed corresponding to the maximum Angle-Of-Attack (AOA) at which Alpha Protection becomes active. **It is only displayed in normal law** and corresponds to the top of the black and amber strip along the PFD speed scale **(fig.5)**.

In practice, the AOA value of the Alpha Protection decreases as the Mach number increases. When the AOA value of the Alpha Protection decreases, the Alpha Protection strip on the PFD moves upward.

$V_{\alpha\text{MAX}}$ is the maximum Angle-Of-Attack speed. It is the speed corresponding to the maximum Angle-Of-Attack the aircraft can fly at in **normal law**. It corresponds to the top of the solid red strip along the PFD speed scale **(fig.5)**.

α_{MAX} is a function of the Mach number: it decreases when the Mach increases **(fig.6)**.

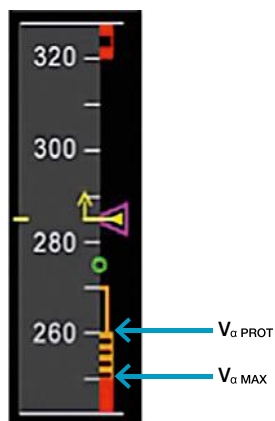

(fig.5)
 $V_{\alpha\text{PROT}}$ and $V_{\alpha\text{MAX}}$ on the PFD speed scale

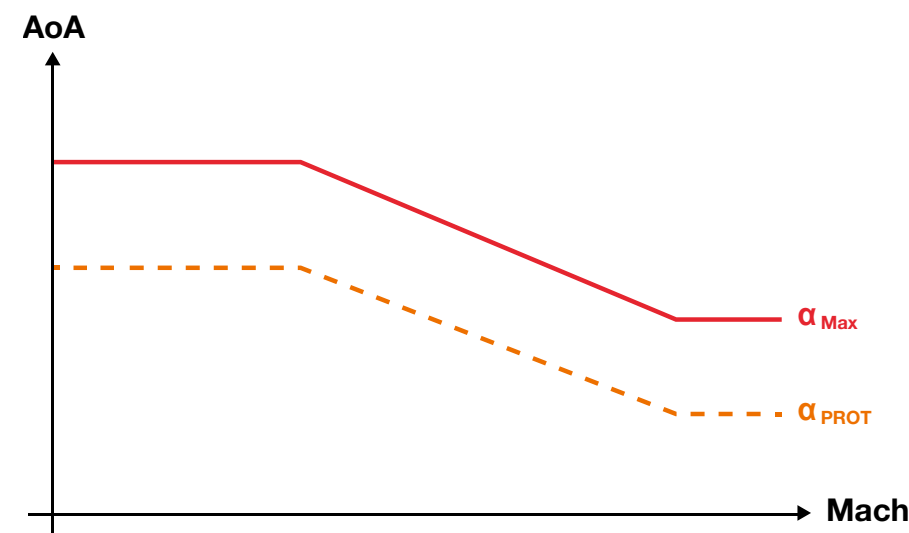

(fig.6)
 Evolution with the Mach number of the AOA value triggering the α Protection and α Maximum, in clean configuration

» **How are $V_{\alpha\text{PROT}}$ and $V_{\alpha\text{MAX}}$ determined?**

Contrary to GD and VLS, $V_{\alpha\text{PROT}}$ and $V_{\alpha\text{MAX}}$ are not based on the aircraft weight, as inserted in the FMS during flight preparation through the ZFW.

$V_{\alpha\text{PROT}}$ (resp. $V_{\alpha\text{MAX}}$) as displayed on the PFD is a prediction of what the

aircraft speed would be if it flew at an Angle-Of-Attack (AOA) equal to α_{PROT} (resp. α_{MAX}). In fact, both speeds are calculated on the basis of the aircraft longitudinal equilibrium equation, along with the actual aircraft speed and AOA.

$$V_{\alpha\text{MAX}} = V_C \times \sqrt{(\alpha - \alpha_0) / (\alpha_{\text{MAX}} - \alpha_0)}$$

$$V_{\alpha\text{PROT}} = V_C \times \sqrt{(\alpha - \alpha_0) / (\alpha_{\text{PROT}} - \alpha_0)}$$

Where:

α_0 is the AOA for a Lift Coefficient (C_L) equal to 0.

V_C is the calibrated airspeed (CAS)

α is current AOA

On the A320 Family, $V_{\alpha\text{PROT}}$ and $V_{\alpha\text{MAX}}$ can have different numerical values on both PFDs because V_C comes from different sources for left and right PFDs.

On A330/A340, A350 and A380 Families, $V_{\alpha\text{PROT}}$ and $V_{\alpha\text{MAX}}$ have the same numerical values on both PFDs.

Data source	A320 Family	A330/A340, A350 and A380 Families
V_C	Left PFD: FAC 1, or FAC 2 if not available in FAC 1. Right PFD: FAC 2, or FAC 1 if not available in FAC 2.	Same value as the one used by the flight controls.
AOA	Same value used for PFD display as the one used by the flight controls.	

“ $V_{\alpha\text{PROT}}$ and $V_{\alpha\text{MAX}}$ are not based on the aircraft weight. ”

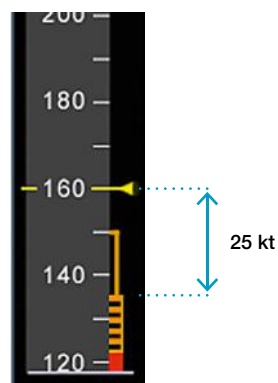

(fig.7)
PFD display of the available speed margin against α_{PROT} and α_{MAX}

In order to avoid a fluctuating $V_{\alpha PROT}$ and $V_{\alpha MAX}$ display, AOA and V_C values are filtered so that fast AOA variations (for example during turbulence) do not pollute the PFD speed scale.

» **What are the operational implications of flying below $V_{\alpha PROT}$?**

At any time during cruise, the actual AOA is compared to α_{PROT} (or α_{MAX}) in real time. The difference of AOA is then converted to speed and applied on each PFD: the delta between current speed and $V_{\alpha PROT}$ (or $V_{\alpha MAX}$) represents the actual margin against α_{PROT} (or α_{MAX}) **(fig.7)**.

In normal law, on a protected aircraft, exceeding the AOA value of the α_{PROT}

As a result of this filtering, a little delay can be observed; therefore during a dynamic maneuver, the aircraft may enter into a protection law with the IAS not yet below the displayed $V_{\alpha PROT}$.

threshold would immediately trigger the high AOA protection, thus resulting in a nose down pitch rate ordered by the flight control laws. Further increasing the AOA by maintaining full back stick would eventually result in reaching the α_{MAX} threshold.

When flying in a degraded law, increasing the AOA would directly expose the aircraft to stall. ■

“ When flying in a degraded law, increasing the AOA would directly expose the aircraft to stall, like on any conventional aircraft. ”

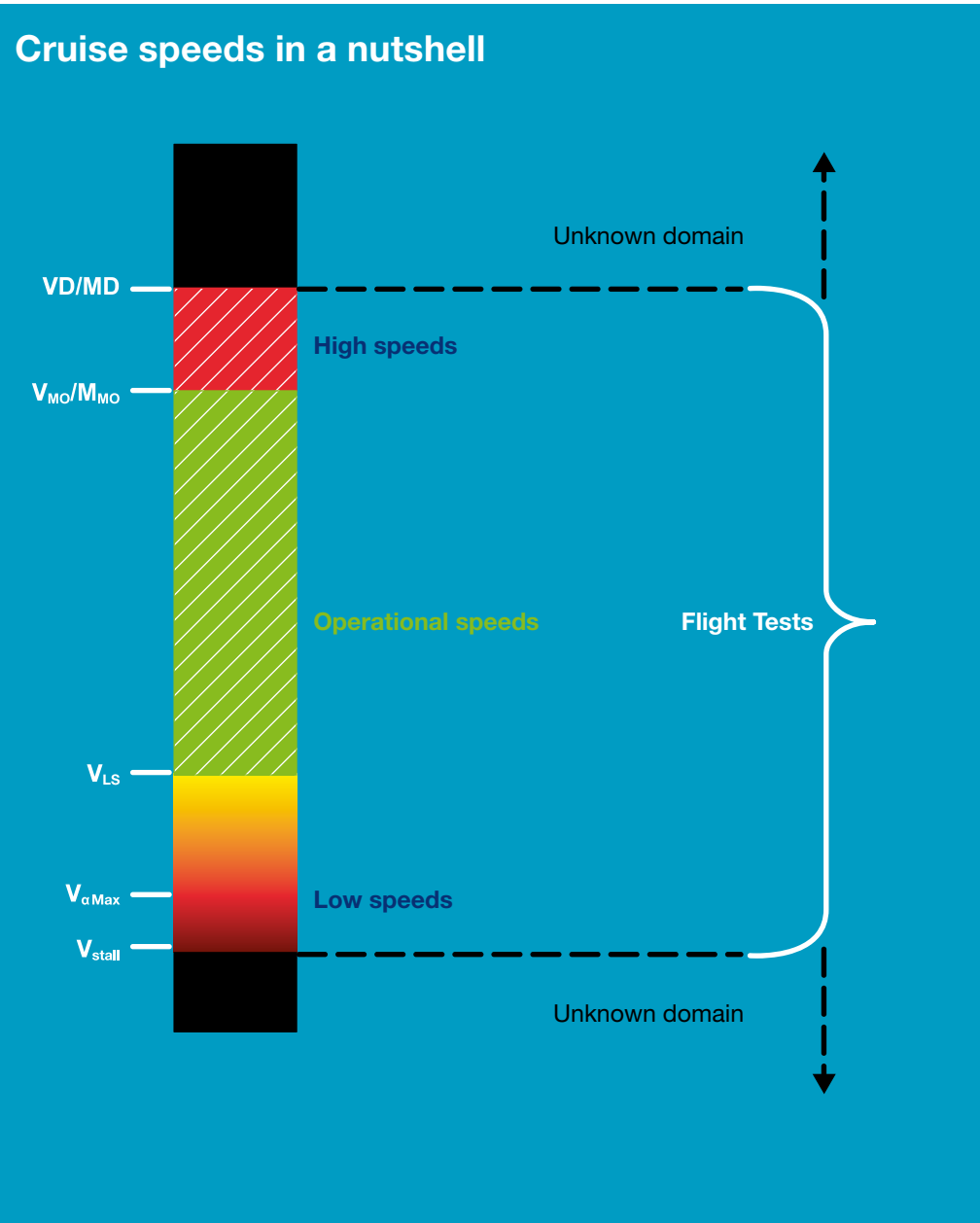

MANAGING YOUR CRUISE: SPEED EXCURSIONS OPERATIONAL RECOMMENDATIONS

Understanding how the aircraft's speed envelope is defined is essential to speed excursion avoidance. Knowing the threats to airspeed and the tools at the crew's disposal to tackle them is another part of that goal. This includes knowing exactly which information should be looked at and how, with the aim to acquire the best possible situational awareness and be able to avoid an overspeed (i.e. V_{MO}/M_{MO} exceedance) or a speed decay (i.e. reaching below V_{LS}), and react wisely in case of an actual encounter.

Reading the first section of this article and understanding how V_{MO}/M_{MO} and VD/MD are determined highlighted that:

At high altitude, reaching the aircraft's structural limit Mach number is almost impossible (except in a steep dive with maximum thrust); therefore at high altitude, flying at high Mach number should not be viewed as the biggest threat to the safety of flight. Conversely, flying too slow (below Green Dot) at high altitude can lead to progressive reductions in speed until the protections are triggered. Should this speed reduction take place in a degraded law, it could lead to a loss of control due to stall. At and near the performance altitude limit of the aircraft, the range of available speeds between Green Dot and M_{MO} will be small. Speed decay at high altitude must be avoided as a result.

- **At lower altitudes** (i.e. below the crossover altitude), too large a speed decay can similarly lead a non protected aircraft (i.e. flying in a degraded law) to enter a stall. Nevertheless, at low altitude, the available envelope is greater and the thrust margin is much higher, thus providing flight crews a greater ability to safely control the airspeed and recover from a speed decay. On the other hand, at low altitude, reaching V_{MO} and VD is possible; therefore high speed should be viewed indeed as a significant threat to the safety of flight.

This chapter offers pilots background knowledge of available prevention means in order to properly manage the main threats to the airspeed, and eventually prevent an overspeed or a speed decay thanks to anticipation and use of dedicated procedures.

How to anticipate a speed excursion

Clearly flight crews are expected to be able to rapidly scan the essential and relevant parameters, in every situation, in every flight phase, including dynamic

ones. In most cases, speed excursion situations are due to rapid wind and temperature variations/evolutions.

“ The biggest threat to the safety of flight both at high and low altitude relates to speed decay. ”

Gaining a good awareness of weather

Weather is an important factor that influences aircraft performances. Be it a local flight or a long haul flight, decisions based on weather can dramatically affect the safety of the flight. As it turns out, the first external threat to airspeed comes from weather disturbances, such as turbulent areas that can lead to significant speed changes. Common sense generally makes pilots avoid those areas; however, they sometimes end up in a situation where some solid turbulence is encountered, when dodging thunderstorms for example. At this point, the airspeed begins to fluctuate, thus making speed exceedance or speed decay more likely. Such situations need to be planned ahead and as far as possible, avoided through regular scanning of weather conditions and flight path adaptation.

The first key to preventing speed excursion events is gaining awareness of the available weather predictions along the forecasted route. Before take-off, the weather briefing has to be as complete as possible. Pilots should check weather reports at alternate and destination airports and, depending on the weather context, this information needs to be updated in flight as often as necessary. Weather information can be communicated either by the Air Traffic Controllers or by the other crews flying in the area. Once airborne, the weather radar is one powerful tool to help the crew make sound weather related decisions to avoid adverse weather and turbulence areas.

Altitude and wind gradients: the main contributing factors

On aircraft with no failure, and the A/THR engaged or the MAX CLB thrust applied in manual mode, a continuous speed decay during cruise phase may be due to:

- A large and continuous increase in tailwind or decrease in headwind, in addition to an increase in the Outside Air Temperature (OAT), that results in a decrease of the REC MAX FL, or
- A large or prolonged downdraft, when the flight crew flies (parallel and) downwind in a mountainous area, due to orographic waves. The downdraft may have a negative vertical speed of more than 500 ft/min. Therefore, if the aircraft is in a downdraft, the aircraft must climb in

order to maintain altitude, and the pitch angle and the thrust values increase. Without sufficient thrust margin, the flight crew may notice that aircraft speed decays, but the REC MAX FL is not modified.

The flight crew must be aware that at high altitude, the thrust margin (difference between the thrust in use and the maximum available thrust) is limited. The maximum available thrust decreases when there is an increase in altitude and/or outside temperature. The REC MAX FL indicated in the FMS decreases when the OAT increases. The nearer the aircraft is to the REC MAX FL, the smaller the thrust margin.

Preventing a speed decay: detecting the phenomenon

At any altitude, decreasing the speed too much will certainly lower the aircraft's level of energy and decrease margins for maneuvering, thus potentially leading to a loss of control due to stall with an aircraft flying in a degraded law. It is important to understand and detect

signs of a significant speed decay in order to be able to recover. When speed decreases, pilots should be attentive to their speed trend vector as displayed on the PFD and take action if an unfavourable speed trend develops in order to remain above GD.

If the speed decreases further, then the Angle-Of-Attack (AOA) must be increased in order to increase the lift coefficient C_L , which keeps the forces balanced. However, it is not possible to indefinitely increase the AOA.

As per basic aerodynamic rules, the lift coefficient C_L increases linearly with the AOA up to a point where the airflow separates from the upper wing surface. If the AOA continues to increase, the point of airflow separation is unstable and rapidly fluctuates back and forth. Consequently, the pressure distribution along the wing profile changes constantly and also changes the lift's position and magnitude. This effect is called **buffeting** and is evidenced by

vibrations. Buffet is a clear sign of an approaching stall or even of the stall itself depending on its severity: it is created by airflow separation and is a function of AOA (**fig.8**).

- At buffet initiation, the pilot starts to feel airflow separation on wings upper surface.
- The buffet onset corresponds by definition to 1.3g (corresponding to 40° of bank angle in level flight).
- The "deterrent buffet" is so strong that any pilot will feel he/she needs to leave these buffet conditions. It corresponds to one of the definitions of stall.

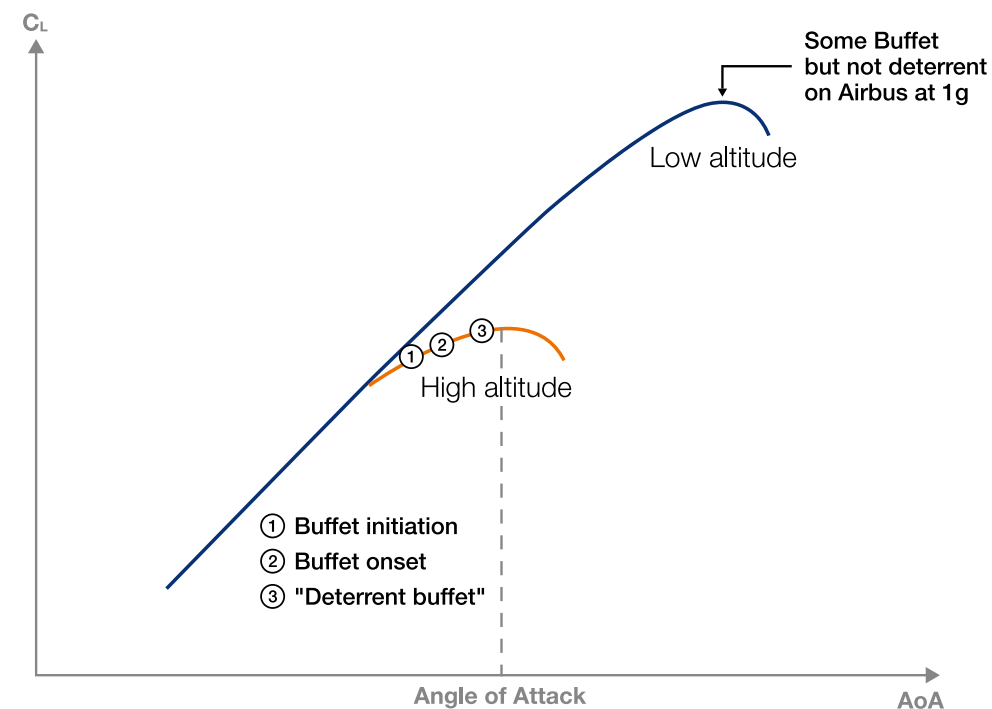

(fig.8)
AOA effect on lift

When the AOA reaches a maximum value, the separation point moves further forward on the wing upper surface and almost total flow separation of the upper surface of the wing is achieved: this phenomenon leads to a significant loss of lift, referred to as a stall. Incidentally, stall is not a pitch issue and can happen at any pitch value.

These conditions should be avoided thanks to anticipation and regular scanning of both the weather conditions along the flown route, and of the speed trend on the PFD. Nevertheless, these conditions might be approached unintentionally. As soon as any stall indication is recognized – be it the aural warning "STALL + CRICKET" or buffet – the aircraft's trajectory becomes difficult to control and the "Stall recovery" procedure must be applied immediately.

“ The nearer the aircraft is to the REC MAX FL, the smaller the thrust margin. ”

“ Stall is not a pitch issue and can happen at any pitch. Stalling is only an AOA issue. ”



NOTE

A video illustrating buffet is presented in the tablet application of Safety first for this issue.

Approach to stall

- **Indications**
 - Artificial stall warnings
 - Some natural stall warning indications may be present
- **Progressive airflow separation**
- **Trajectory controllable with decreasing margin for maneuvering**

Stall

- **Indications**
 - Artificial stall warnings
 - Natural stall warnings
 - Buffeting
 - Lack of pitch authority
 - Lack of roll control
 - Inability to arrest descent
- **Airflow separated from wing**
- **Trajectory no longer controllable**

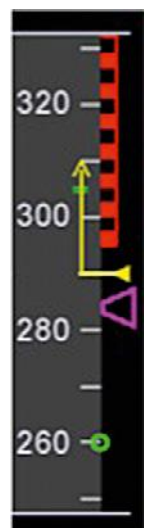

Preventing and recovering from a V_{MO}/M_{MO} exceedance: dedicated procedures

Using dedicated procedures

As soon as an unfavourable speed trend develops, pilots must take action and prevent a speed exceedance, following the operating techniques and recommendations detailed in the OVERSPEED PREVENTION procedure.



DID YOU KNOW

On the A320 Family, speed brakes extension and retraction rates at high Mach/Vc are roughly twice as slower Auto Pilot (AP) engaged compared with AP disengaged. As a consequence, if used to avoid a V_{MO}/M_{MO} exceedance, crew should keep this in mind to retract them timely in order to avoid reducing their speed below GD. This is particularly true when flying close to REC MAX.

In most cases, the use of this OVERSPEED PREVENTION procedure will effectively prevent exceeding V_{MO}/M_{MO} . Nevertheless, due to system design and limited authority, this may not be sufficient. For this reason, a OVERSPEED RECOVERY procedure was developed as well and implemented in the FCOM /QRH.

The OVERSPEED warning is triggered when the speed exceeds $V_{MO} + 4$ kt or $M_{MO} + 0.006$, and lasts until the speed is below V_{MO}/M_{MO} . In this case, the flight crew must apply the OVERSPEED RECOVERY procedure.

Maintaining the aircraft after a V_{MO}/M_{MO} exceedance

The flight crew must report any type of overspeed event (i.e. if the OVERSPEED warning is triggered). Indeed, in case of an overspeed, an inspection of the aircraft structure may be required. Indeed, when an overspeed event occurs, the aircraft may experience a high load factor. Only an analysis of

flight data allows to tell whether or not an inspection is required.

This supports the crucial need for flight crews experiencing an overspeed to report it! Then maintenance and engineering teams will judge whether or not further inspection is needed. ■



“ Any type of overspeed must be reported by the flight crew. Only an analysis of flight data allows to tell whether or not an inspection is required. ”

In cruise, the aircraft airspeed might not be the desired one at all times. The aircraft may encounter adverse weather and turbulences, or even winds, which all have a direct impact on the airspeed. For this reason, flight crews must remain vigilant at all times and anticipate the main threats to the airspeed by planning ahead and communicating.

In practice, once the aircraft is airborne, pilots must be fully cognisant of the airspeed as well as the speed trends at all times in flight. In case of need, the FCOM/QRH and FCTM provide procedures and adequate guidelines to prevent and to recover from a speed excursion, and react wisely to any variation of airspeed. They are worth being thoroughly read and understood in advance.



DID YOU KNOW

To know more about speeds, read our brochure “Getting to grips with aircraft performance”, available on AirbusWorld.



Lithium batteries: safe to fly?

Today, Lithium batteries play a barely visible, yet essential role in both our daily life and aviation alike. Manufactured and handled correctly, Lithium batteries are safe. But production failures, mishandling, or not being aware of their specific characteristics can have serious repercussions.



CHRISTINE BEZARD
Head of Human Factors & Ergonomics in design - Safety advisor



IAN GOODWIN
Director Flight Safety - Safety Enhancement



PEIMANN TOFIGHI-NIAKI
Flight Safety Enhancement - Flight Operations and Training Support



PAUL ROHRBACH
Fire Protection - Project leader Lithium batteries as cargo

Lithium batteries are today's power source of choice. As we become ever more reliant on Portable Electronic Devices (PEDs) to provide at your fingertips information, entertainment and communication, then so increases the demand for more powerful, yet lighter, sources of power.

Hundreds of millions of Lithium batteries or equipment with Lithium batteries are carried on aircraft annually. These can be as part of passengers carry-on items, as aircraft (e.g. Portable IFE, defibrillators) or aircrew equipment (such as Electronic Flight Bags). They can be shipped as cargo in battery form or within other purchased items to support the demand for "just in time deliveries", or indeed as power supply for aircraft equipment. Lithium batteries are becoming continually more common place in the aircraft environment.

But the introduction of Lithium batteries included some highly visible cases of cell phones or laptops self-igniting and burning. Likewise, several events have occurred on aircraft, ranging from localized and limited fires to large, uncontrolled in-flight fires resulting in hull losses and fatalities.

The air industry has become more aware of the specific characteristics of Lithium batteries and the associated risks can now be mitigated. Procedures have been developed to address the risks for Lithium batteries being part of the aircraft design, those belonging to passengers or crews carry-on items, or indeed procedures linked to the shipping of Lithium batteries as cargo.

LITHIUM BATTERIES: A POWERFUL AND VERSATILE TECHNOLOGY, ASSOCIATED WITH A COMMON RISK

Lithium is the metal with the lowest density, but with the greatest electrochemical potential and energy-to-weight ratio, meaning that it has excellent energy storage capacity. These large energy density and low weight characteristics make it an ideal material to act as a power source for any application where weight is an issue, aircraft applications being a natural candidate.

While the technology used and the

intrinsic risk is the same for all applications, different solutions and procedures exist to mitigate this common risk depending on where and how the Lithium battery is used (i.e. part of the aircraft design, transported as cargo or in passengers and crews luggage and PED). This section will highlight the benefits of this new technology irrespective of its use in applications, and describe the associated risk of "thermal runaway".

Lithium: an increasing use

Experimentation with Lithium batteries began in 1912 and the first Lithium batteries were sold in the 1970's. In the nineties, Lithium battery technology began to be widely used by a number of industries that were looking for light,

powerful and durable batteries. As it turns out, Lithium use in batteries has been one of the major drivers of Lithium demand since the rechargeable Lithium-ion battery was invented in the early nineties **(fig.1)**.

(fig.1)
Forecast Lithium demand by application (Source: TRU Group)

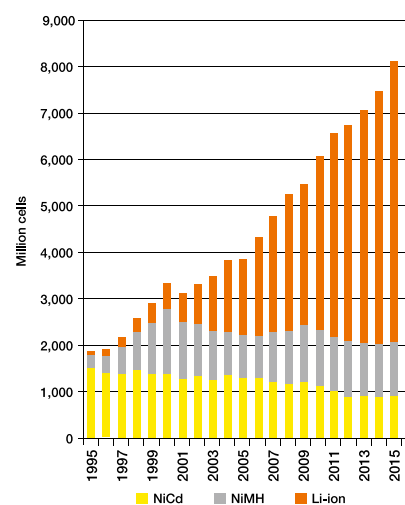
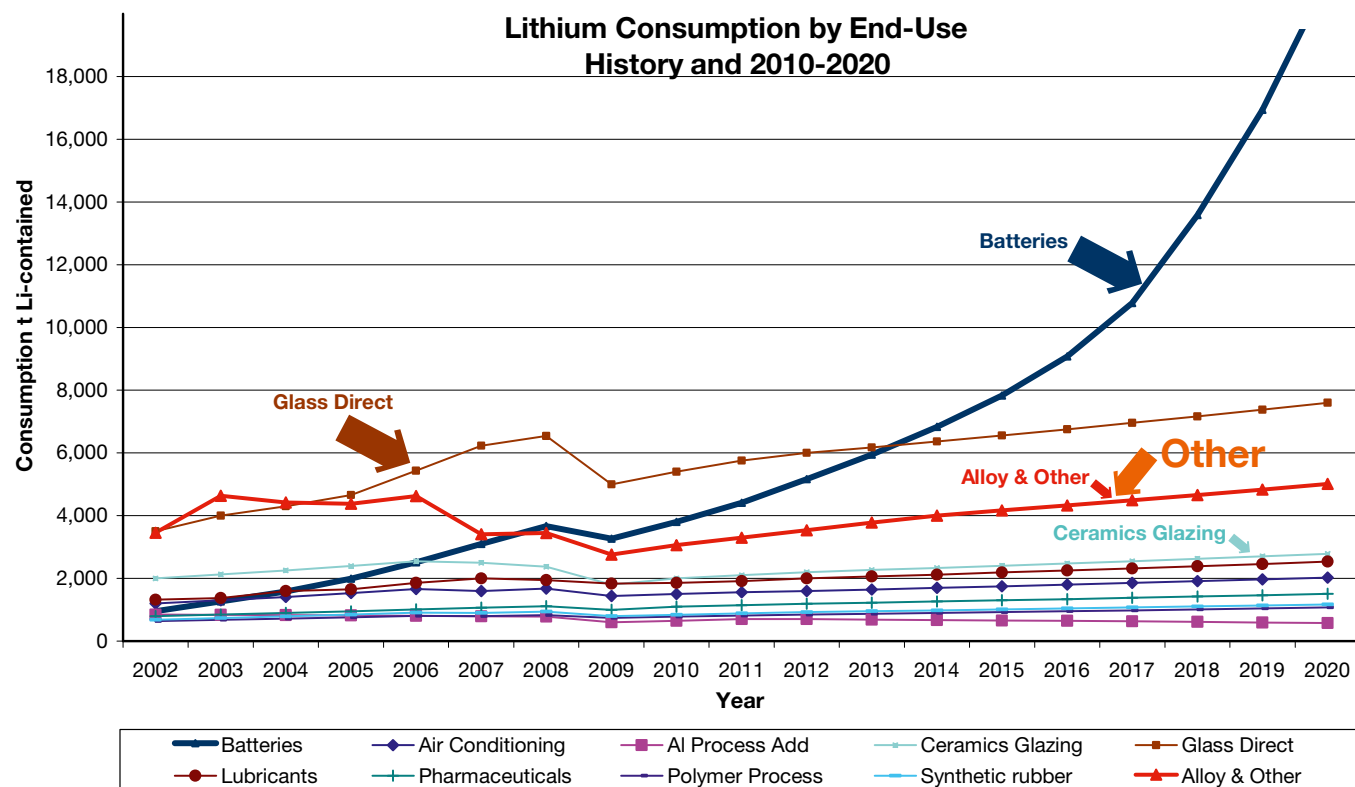

Today, Lithium batteries are progressively replacing previous technology batteries – e.g. Nickel-Cadmium, Lead-acid – and can be found in most of electronic and autonomous electric systems or equipment. Development and applications are evolving with latest uses including ultrathin (down to 0.5 mm) and flexible technologies.

The Lithium battery market is extremely dynamic and expanding fast, with a growing application as the power source for a wide range of electric vehicles. In fact, no level off is foreseen in the coming years. In 2014, 5.5 billion Lithium-ion batteries were produced **(fig.2)**.

(fig.2)
Worldwide batteries production (Source: Christophe PILLOT, Avicenne Energy)

Different types of Lithium batteries, different applications

Different types

Lithium batteries can take many forms. They can be as tiny as single cell button batteries – for example used as power supply for watches – or multi cells

(usually rechargeable) batteries that can act as high power energy sources for electric vehicles, or indeed as back-up power supply on-board aircraft **(fig.3)**.

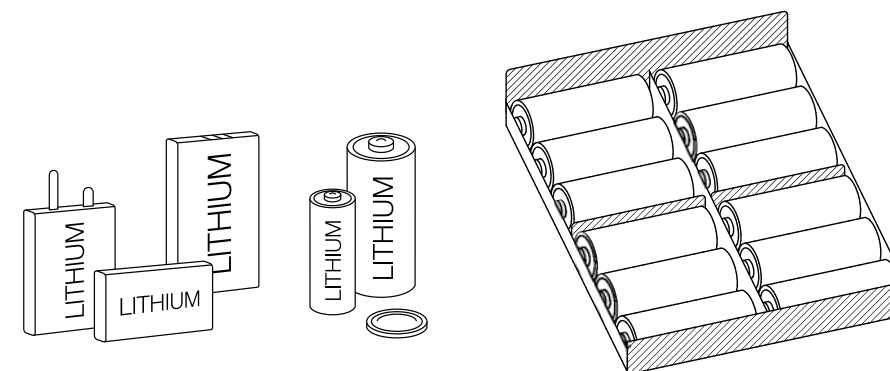

(fig.3)
Types of Lithium batteries: single/multi cells

Different technologies

The term “Lithium battery” actually refers to a family of batteries that can be divided into two categories:

» **Primary: Lithium-metal, non-rechargeable batteries**

These include coin or cylindrical batteries used in calculators, digital cameras and emergency (back-up) applications for example **(fig.4)**.

Lithium-metal batteries have a higher specific energy compared to all other batteries, as well as low weight and a long shelf and operating life.

(fig.4)
Lithium-metal batteries

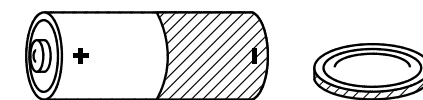

» **Secondary: Lithium-ion / Lithium-polymer rechargeable batteries**

Key current applications for this type of batteries are in powering cell phones, laptops or other hand held electronic devices, as well as electric/hybrid cars and power stores **(fig.5)**.

The advantages of the Lithium-ion or Lithium-polymer battery are its ability to be recharged in addition to its higher energy density and lighter weight compared to nickel-cadmium and nickel-metal hybrid batteries.

(fig.5)
Lithium-ion / Lithium-polymer batteries

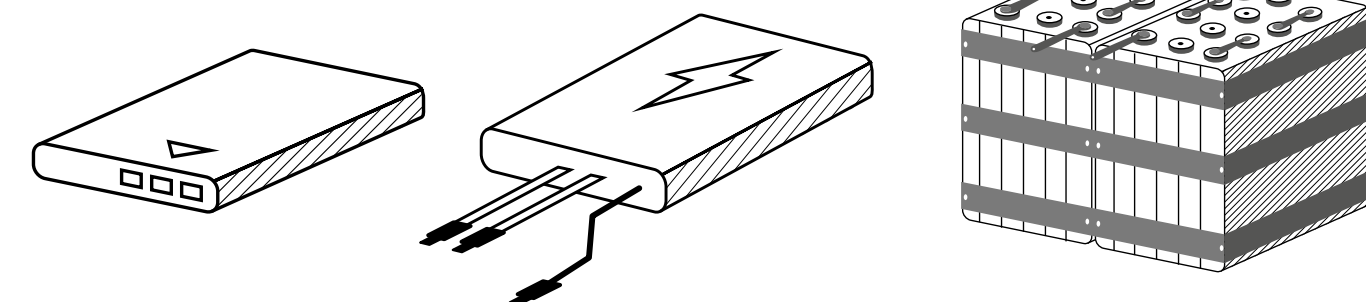

“ Lithium batteries can be both a source of fire through self-ignition and thermal runaway, and a cause of fire by igniting surrounding flammable material. ”

One main intrinsic risk to tackle: the thermal runaway

As with every new technology, Lithium batteries offer a number of advantages, but they also come with limitations. Although previous batteries technologies were not risk-free, Lithium based batteries have a larger electrochemical potential; therefore if damaged, mishandled or

poorly manufactured, they can suffer stability issues and be subject to what is called a “thermal runaway”. This phenomenon is well recognized now, and it can be mitigated providing awareness and prevention actions are taken.

A self-ignited and highly propagative phenomenon

In case of internal degradation or damage, a battery cell rapidly releases its stored energy (potential and chemical) through a very energetic venting reaction, which in turn can generate smoke, flammable gas, heat (up to 600°C and 1000°C locally), fire, explosion, or a spray of flammable electrolyte. The amount of energy released is directly related to the electrochemical energy stored and the type of battery (chemic and design).

Both the primary and secondary types of batteries are capable of self-ignition and thermal runaway. And once this process is initiated, it easily can propagate because it generates sufficient heat to induce adjacent batteries into the same thermal runaway state. Lithium batteries can be both a source of fire through self-ignition and thermal runaway, and a cause of fire by igniting surrounding flammable material.

INSIGHT INTO THE THERMAL RUNAWAY PHENOMENON

A thermal runaway consists in an uncontrolled energy release. It refers to a situation where an increase in temperature changes the conditions in a way that causes a further increase in temperature, often leading to a destructive result.

In multi-cell batteries, the thermal runaway can then propagate to the remaining cells, potentially resulting in meltdown of the cell or a build-up of internal battery pressure resulting in an explosion or uncontrolled fire of the battery.

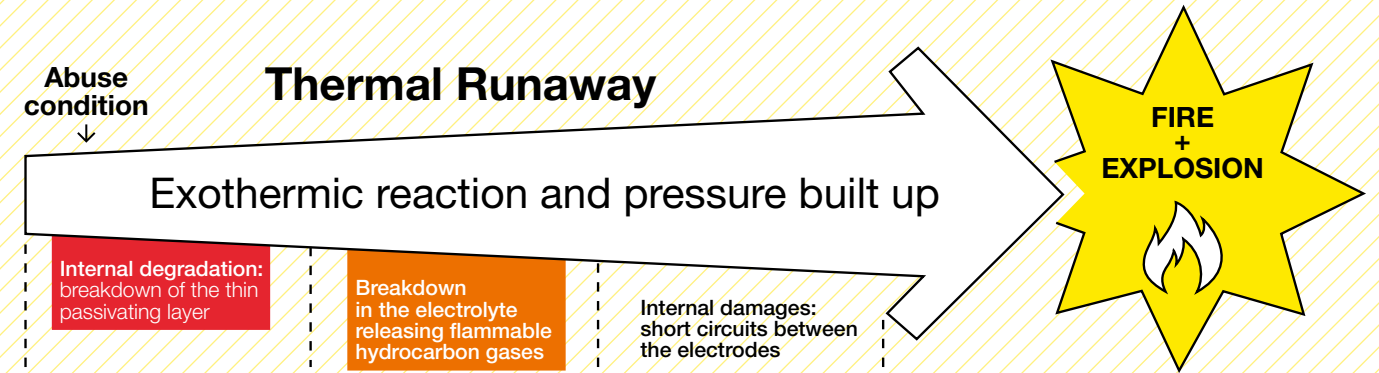
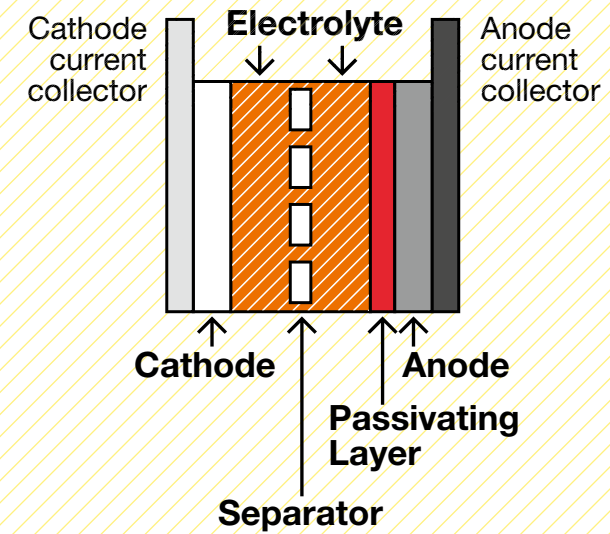
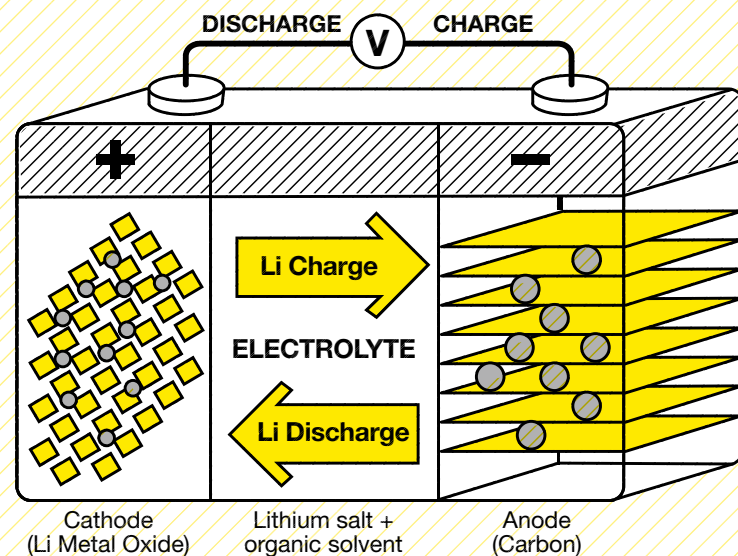

The main factors contributing to a thermal runaway are:

- Poor design or poor integration
- Poor cell or battery manufacturing quality
- Poor safety monitoring or protection
- Poor handling / storage / packing conditions

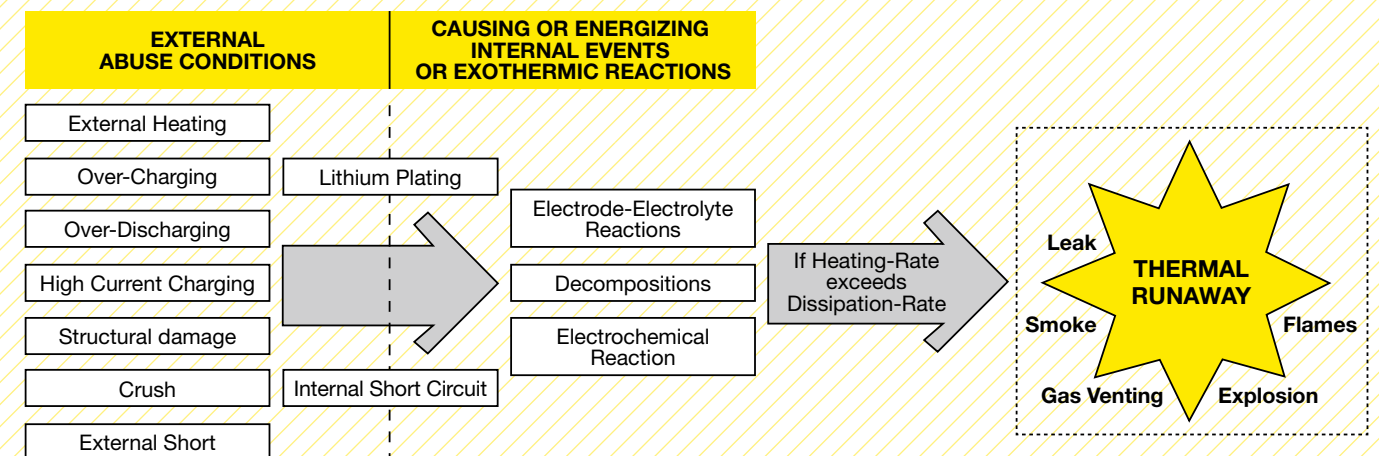

In-service experience

By their nature and properties, large numbers of Lithium batteries can be found in many places on-board an aircraft **(fig.6)**:

○ In the cabin among the personal effects of crews and passengers

● In the cockpit as part of tablets used for flight data support

● In the cargo holds carried as cargo or in passengers baggage

● In the aircraft design.

(fig.6)
Lithium batteries on-board an aircraft

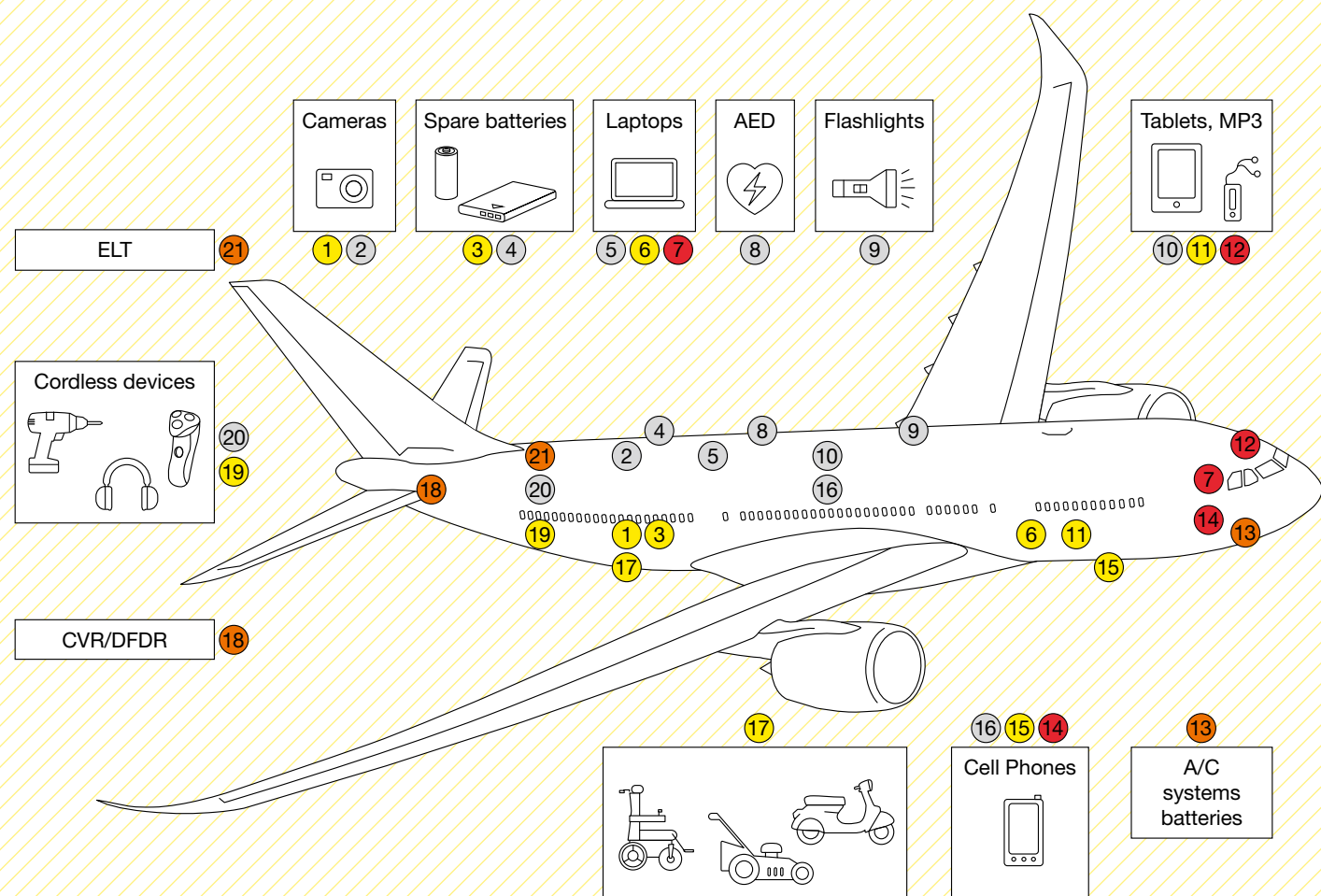

FAA tests show that even a small number of overheating batteries emit gases that can cause explosions and fires that cannot be prevented by traditional fire suppression systems. In view of the possible consequences, Lithium batteries are classified as

hazardous materials, therefore particular care and consideration must be taken to ensure safe operations in relation to use and transport of Lithium batteries (or devices containing Lithium batteries) when in an aircraft environment. ■

“ Lithium batteries are classified as hazardous materials. ”



Damage to cabin overhead compartment video camera

Hull loss

Battery fire

(fig.7)
Consequences of Lithium batteries thermal runaway

Since March 20th, 1991, the FAA has recorded 158 incidents involving batteries carried as cargo or baggage according to their report on “Batteries & Battery-Power Devices – Aviation Cargo and Passenger Incidents Involving Smoke, Fire, Extreme Heat or Explosion” dated 30 June 2015. 81 of these events related to Lithium batteries.

The phenomenon of thermal runaway in an aircraft environment can be catastrophic. At the least it can range from limited degradation of personal equipment, or minor damage to the overhead storage compartment. In the case worst situation, thermal runaway in high density package of Lithium batteries can result - and has been implicated - in hull losses **(fig.7)**.

HOW TO MITIGATE THE RISKS POSED BY LITHIUM BATTERIES

Although investigation into reported events highlighted that some Lithium batteries fires were due to internal short circuits relating to design, manufacturing or integration shortcomings, many – if not most – fires were caused by abuse by the user. This may be deliberate or negligent abuse or physical damage due to mishandling, but

quite often it is unconscious abuse. Also, while strict regulations for transporting Lithium batteries as cargo exist, several incidents have been related to Lithium batteries being in the cabin. For this reason, a good awareness on risks posed by Lithium batteries of both airlines personnel and their passengers is crucial.

“ The Lithium batteries embedded in the aircraft design are subject to strict development and integration requirements, complying with the highest safety standards. ”

Permanently installed batteries

Mitigating the risks posed by Lithium batteries and preventing a thermal runaway or a fire starts with securing the batteries that form part of the aircraft design. In this respect, the Lithium batteries embedded in the aircraft design are subject to strict development and integration requirements, complying with the highest safety standards. The intrinsic risk of this new generation of Lithium based batteries is acknowledged at all levels of the aircraft design phase, as early as from the inception of the product and its systems. It is then mitigated thanks to acceptability justification based on each battery location, and a thorough review of installation, ensuring that no heat source and hazardous material or fluids are in the vicinity.

During an aircraft’s service life, this risk can be mitigated by adhering to common sense precautions, such as using only the Original Equipment Manufacturer (OEM) parts. The use of counterfeit or non-authorized parts increases the risk of fire and explosion. Consequently, complying with the Airbus Parts Catalogue and exclusively using Airbus or OEM catalogue references for spare batteries is key. Similarly, before installing spare batteries in Buyer Furnished Equipment (BFE) or in aircraft, operators should ensure the parts are genuine spare parts, that they have been stored and handled appropriately and present no mark of overheat or damage.

? DID YOU KNOW

More information about the consequences on use of non-approved batteries can be found in OIT 999.0032/03 Rev 01, OIT 999.0035/04 and OIT 999.0145/14.

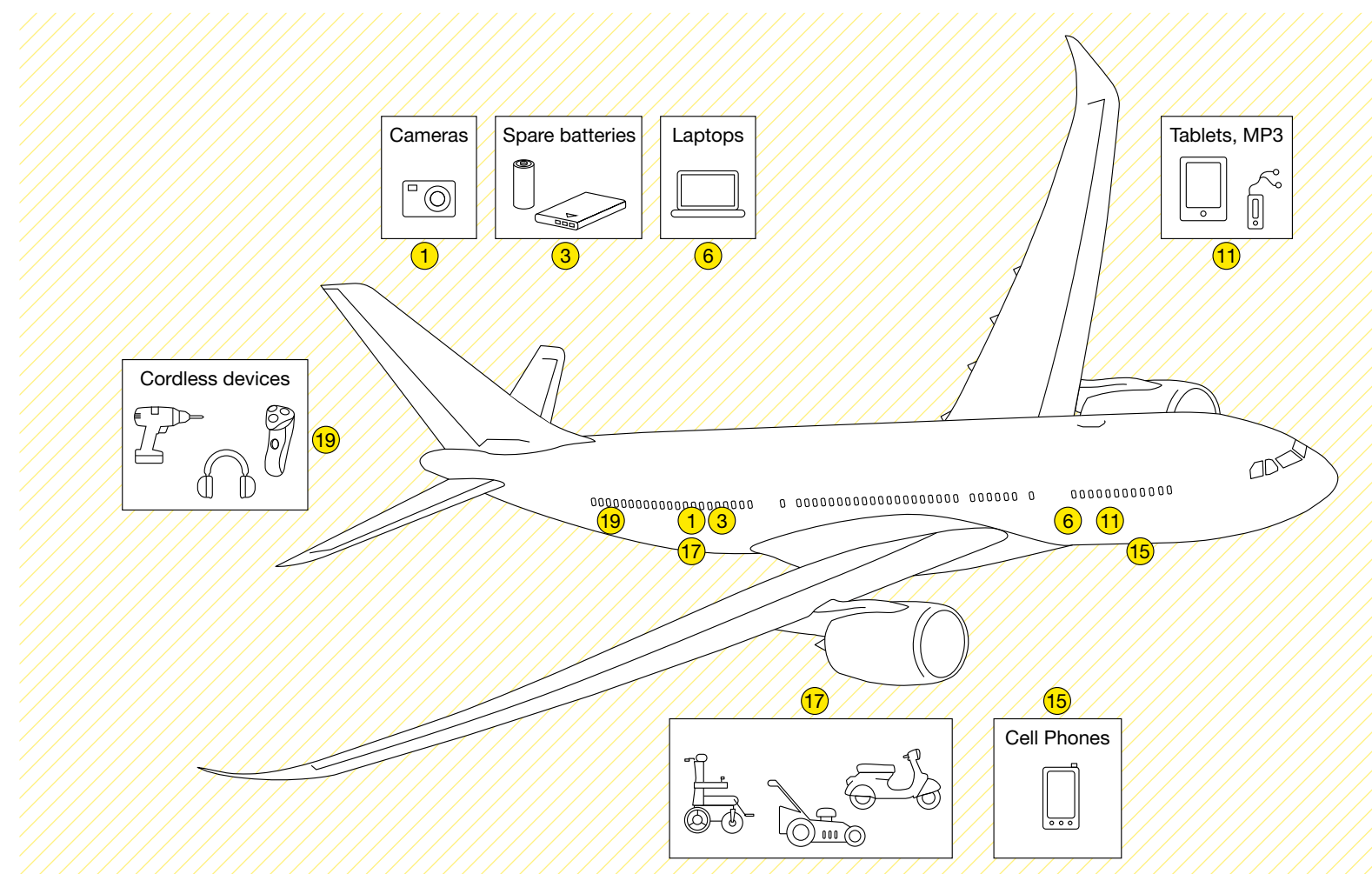
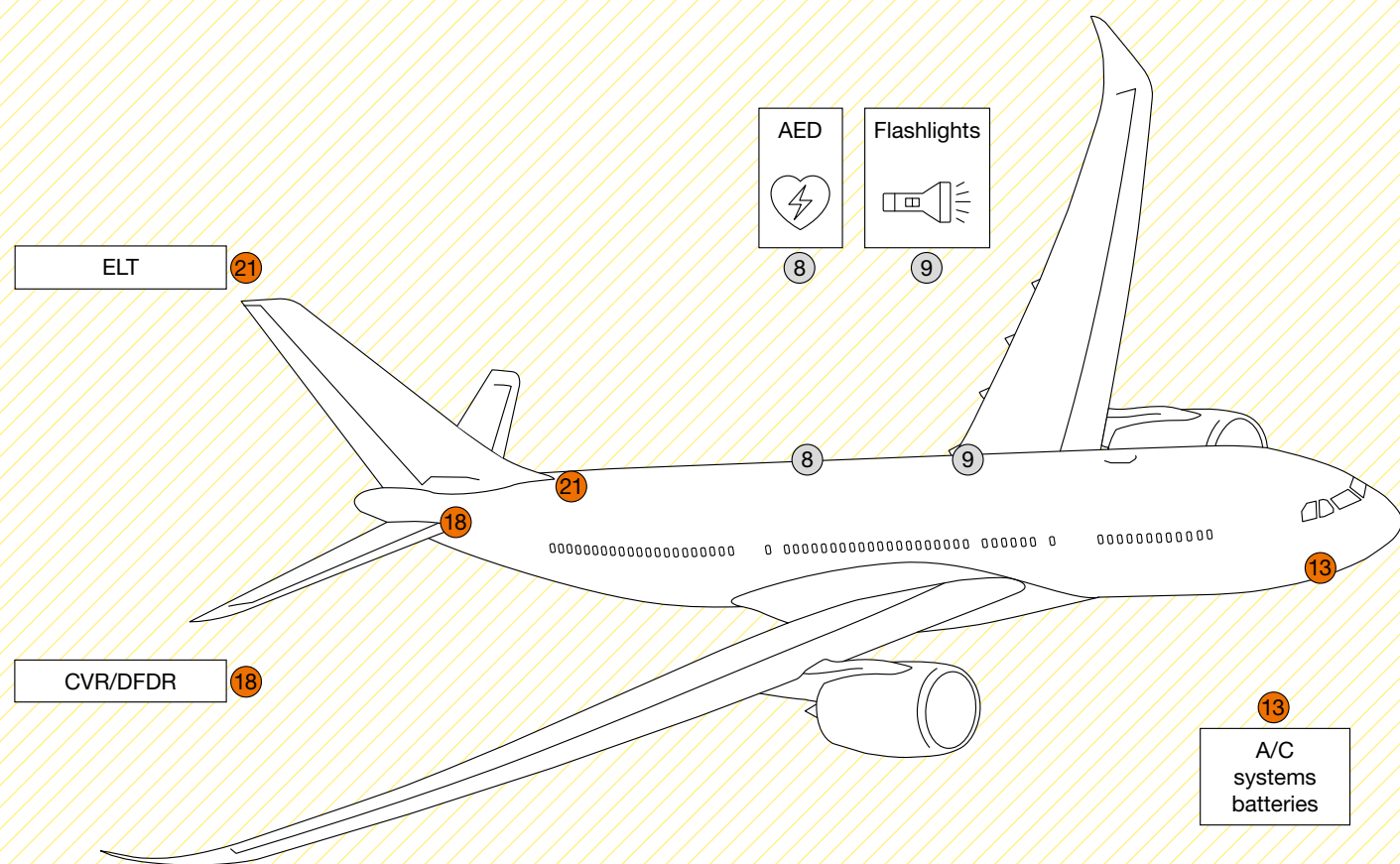

Carriage of Lithium batteries as air cargo

Increased usage of Lithium batteries as the power supply of choice has, not surprisingly, led to an increase in the shipping of Lithium batteries as air cargo. Today, one of the main risks posed by Lithium batteries is related to the shipping as freight. The existing ICAO regulations do not regulate the quantity of Lithium

batteries that can be shipped as cargo on any single aircraft as a cargo load. The only limitations are associated to what can be loaded into each individual package. It is also worth understanding that these same regulations are not intended to control or contain a fire within that packaging.

What protection can the existing cargo compartment fire protection provide in the event of a Lithium battery fire?

Today’s cargo fire protection of an aircraft is addressed by:

- Passive protection (cargo hold linings or protection of essential systems)
- Detection
- Suppression (use of Halon) or oxygen starvation
- Preventing hazardous smoke / extinguishing agents into occupied compartments.

Investigations have shown that the cargo compartment fire protection standards described in CS/FAR25 are not sufficient to protect the aircraft from fires involving high density shipments of Lithium batteries. “High density” describes a quantity of Lithium batteries that has the potential to overwhelm the cargo compartment fire protection system. In fact, the

“ Today’s cargo compartments do not demonstrate resistance to a fire involving Lithium-metal and Lithium-ion batteries. ”

impact of different characteristics of the batteries (e.g. chemistry, state of charge, size), cargo compartments types and loading configurations make it very difficult to define a quantity limitation that could be recommended at aircraft level, for all operational situations. Tests have demonstrated that some configurations, involving only one item of the regulated packaging size, has the potential to lead to significant damage of an aircraft.

Irrespective of the size of the shipment, research into the impact of both Lithium-metal and Lithium-ion batteries fire has demonstrated that the existing cargo compartment fire suppression systems – namely Halon 1301 (class C) or oxygen starvation (class E) – are unable to stop a thermal runaway and prevent propagation to adjacent cells. If a thermal runaway is initiated, heat and flammable gases coming from the degradation of the hydrocarbon electrolyte will be emitted. The existing fire protection cargo sys-

tems are not capable of containing these accumulated gases.

The passive protection standards are designed to withstand heat sources for up to 5 minutes and are not resistant against the characteristics of a Lithium battery fire. The temperature, duration and intensity of such a fire will quickly overwhelm the passive protections. In addition, the quantity and continuing production of smoke produced is likely to overwhelm the passive and active smoke barriers that protect the occupied compartments.

With these findings, the aviation industry came to the conclusion that today’s cargo compartments, which are certified to US CFR Part 25.857 and EASA CS 25.857, do not demonstrate resistance to a fire involving Lithium-metal and Lithium-ion batteries. For this reason, the inability to contain a Lithium battery fire for sufficient time to secure safe flight and landing of the aircraft, is an identified risk to the air transport industry.

What the regulations say

In the light of the risks identified, in January 2015, the ICAO Dangerous Goods Panel took the position to ban the carriage of Lithium-metal batteries of all types, as cargo on passenger aircraft.

However, whilst this was an important development, Lithium-metal batteries only account for a small proportion of all Lithium batteries carried annually as air cargo. Consequently, research into the impact of a Lithium-ion batteries fire has continued. As already noted, this research has demonstrated that Lithium-ion batteries themselves represent a significant threat due to the fact that the existing cargo compartment fire suppression functions are ineffective against a Lithium-ion battery fire.

As a result, regulatory authorities are now heading towards a larger ban on Lithium battery shipments as cargo on passenger planes that would include

non-rechargeable and rechargeable batteries alike. At time of publication of this article, these discussions are on-going. At their last meeting in October 2015, the ICAO Dangerous Goods Panel (DGP) proposed a 30% State of Charge (SoC) limit as an interim measure aiming to reduce the risk of fire propagation to adjacent batteries and thereby improve aviation safety.

At the same time, discussions in ICAO are focussing on establishing appropriate packaging and shipping requirements to ensure safer shipment of Lithium-ion batteries. Airbus is also involved in the Civil Aviation Safety Team (CAST) investigating overall approaches from the battery itself to a combination of packaging / container and the aircraft itself.

The importance of correct transport and shipping of Lithium batteries therefore becomes key, and the involvement of the shipper and operator is crucial.

“ Primary (non-rechargeable) Lithium-metal batteries are forbidden for transportation aboard passenger-carrying aircraft. ”

CATEGORIZATION OF CARGO COMPARTMENTS

Cargo compartments of the Airbus fleet are certified as class C and class E compartments according to CS 25.857. Additionally, some aircraft in service still have class D cargo compartments, but this classification was eliminated for new production in 1998.

- Class C compartments are required for passenger aircraft compartments not accessible during flight (lower deck) or if a fire could not be controlled from the entrance point, without entering the compartment. A class C compartment needs to be equipped with:
 - Smoke/fire detection system
 - Ventilation control
 - Built-in fire suppression system
 - Fire resistant linings (passive protection)
 - It needs to be demonstrated that no hazardous quantity of smoke, flames or fire extinguishing agents are able to enter occupied areas.

- Class D compartments need to be equipped with:
 - Ventilation control
 - Fire resistant linings (passive protection)
 - It needs to be demonstrated that no hazardous quantity of smoke or flames are able to enter occupied areas.
- Class E compartments are only allowed for freighter aircraft. They need to be equipped with:
 - Smoke/fire detection system
 - Ventilation control
 - Only critical systems need to be protected from fire
 - It needs to be demonstrated that no hazardous quantity of smoke, flames or noxious gases are able to enter occupied areas.



What shippers and operators can do: risk assessment and best practices

1. Check the latest industry available information and guidance

Air transport of Lithium batteries is controlled by international and local regulations. If transporting Lithium batteries, operators need to first check the latest instructions for the safe transport of dangerous goods by air, be they provided through Airworthiness Authorities or local regulations, and/or the ICAO.

2. Perform a risk assessment

In the end, the responsibility for the safe carriage of dangerous goods (including Lithium batteries) lies with the shipper and operator. It is recommended that if carriage of dangerous goods is pursued, then a safety risk assessment of cargo operations should be performed to determine if battery shipments can be handled safely.

With respect to Lithium batteries, guidelines for the assessment should consider factors such as:

- The quantity and density of Lithium battery shipment
- The type of Lithium batteries to be shipped
- Who the supplier/shipper of Lithium batteries is and their quality control
- The identification and notification of all shipments of Lithium batteries (also Section II Lithium batteries)
- Accepting only Lithium battery shipments that comply with appli-

cable regulations (ICAO and/or local regulations)

- Overall capability of the aircraft and its systems
- Segregation possibilities of Lithium batteries from other flammable/explosive dangerous goods.

3. Ensure safe packaging and shipping

Local and/or international regulations provide the applicable set of rules that need to be complied with when transporting Lithium batteries. Attention should be given to:

- Training and awareness of employees regarding:
 - The aircraft limitations against a Lithium battery fire and existing mitigation means.
 - Regulations, handling procedures, the dangers of mishandling, and methods to identify Lithium battery shipments.
- Packaging:
 - Clearly identify shipments of Lithium batteries by information on airway bills and other documents.
 - Make sure that the packaging is correctly labelled and identified as dangerous goods according to ICAO technical instructions.
 - Do not ship damaged packages.
- Cargo loading: segregate any Lithium battery shipments from other dangerous goods that present a fire hazard (flammable and explosive goods).

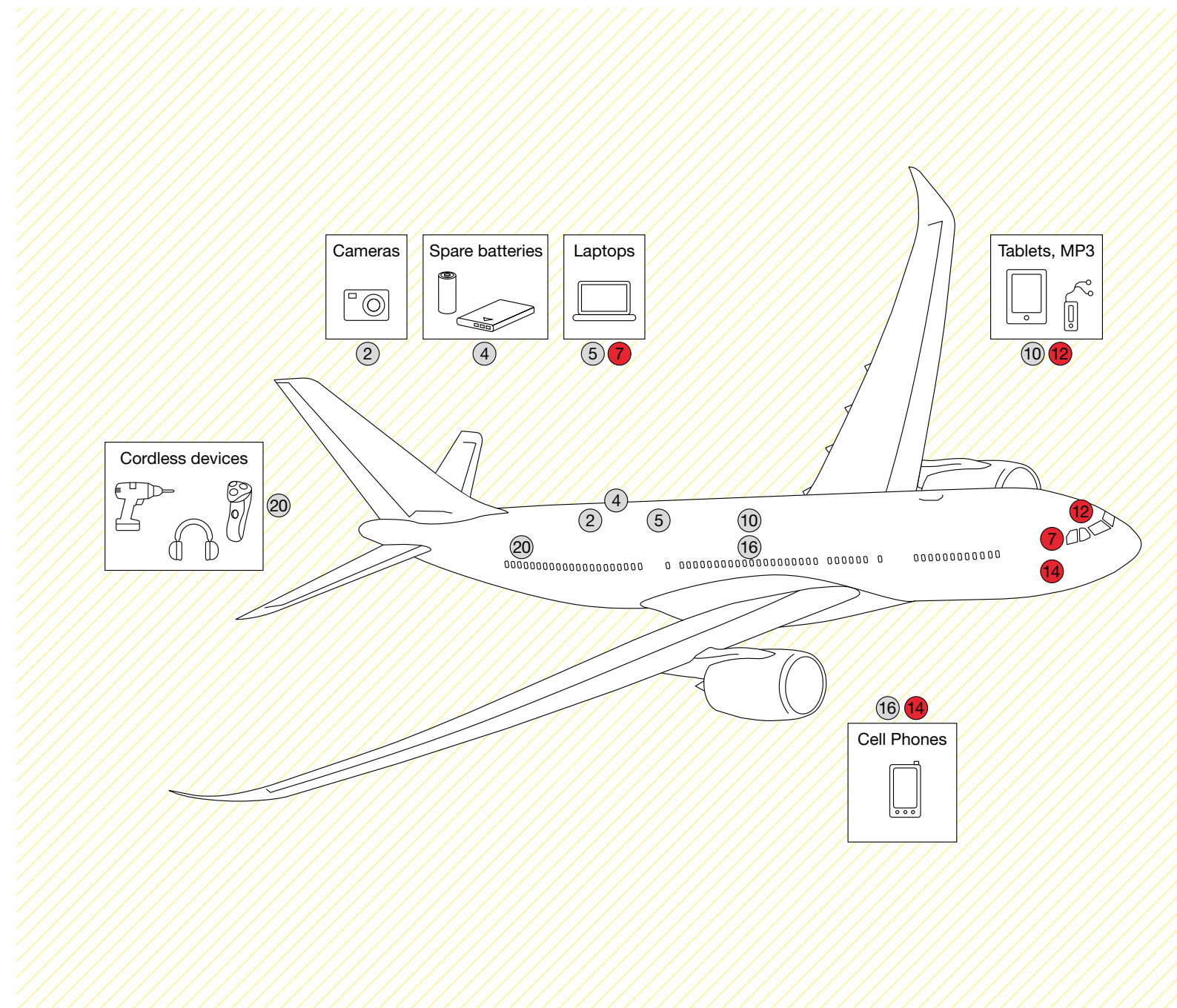

? DID YOU KNOW

More information on the carriage of Lithium-ion batteries is provided in Airbus ISI 00.00.00182 dated 24 July 2015. Industry Guidance, such as the IATA “Lithium Batteries Risk Mitigation Guidance for Operators” also provides useful information for mitigating the risk on the carriage of Lithium batteries.

Carriage of Lithium batteries in the cabin

Whilst recent discussions have shifted the focus towards the carriage of large quantities of Lithium batteries as cargo, due to their proliferation and use in many applications, operators need to also be aware of the risk of carrying Lithium batteries in passenger baggage – both checked in, off loaded cabin baggage and also carry-on cabin baggage.

The widespread use of Lithium batteries means that hundreds of Portable Electronic Devices (PED) are likely to be carried on a large aircraft, either in hold baggage or as carry on. Prevention is therefore essential to raise passengers’ awareness of the risks associated to carrying Lithium batteries.

Raising passengers awareness before boarding

Recommendations have been developed with respect to what can or cannot be carried in passenger baggage. ICAO and IATA regulated and recommended general requirements with regards to carrying and managing what is carried in passenger baggage is that:

- Batteries carried should have been appropriately tested (e.g. should be manufactured by the original manufacturer).
- PEDs containing Lithium batteries should be carried in carry-on baggage.
- Spare batteries (i.e. those not contained in a PED), regardless of size, MUST be in carry-on baggage. They are forbidden in checked baggage and should be appropriately protected against short circuit, e.g. by leaving the batteries in its original retail packaging.

- Consider the quantity carried by individuals. Whilst there is no limit on the number of PEDs or spare batteries, below a specified size (normally 100 Watt-hour) that a passenger or crew member may carry, but they must be for personal use.

The key however is making both the customer facing representatives and the passenger themselves aware of the risks presented by the incorrect carriage of Lithium batteries, and making sure that they know the regulations. To increase the awareness to the travelling public, posters and Lithium battery pamphlets can be a useful option and are widely used by air carriers and authorities around the world alike. As an example, FAA have issued Safety Alerts for Operators (SAFO) number 15010, which deals with "Carriage of Spare Lithium Batteries in Carry-on and Checked Baggage".

Raising passengers awareness on-board

A key aspect to mitigating the risk is making the owner, namely the passenger, aware of the risks inherent to Lithium batteries being used in an aircraft environment. Make sure passengers are aware of what is allowed in the terms of Lithium batteries in carry-on baggage, and the requirement for correct storage, but also impact of a PED getting trapped in the movable seat mechanism.

Due to their small size, PEDs can easily be trapped in seat mechanisms. The

subsequent crushing of PEDs during adjustment of the seat can lead to overheat and thermal runaway. Making passengers aware of this inherent risk can help reduce this scenario. For example, including a note in the pre-flight briefing to ensure that in case a PED is lost, then the seat is not moved until the component is retrieved is an option. Likewise, making cabin and flight crew aware of this potential failure mode is key to quick and efficient action when addressing a fire caused by a PED.

i INFORMATION

IATA has issued more information on the risk mitigations for operators on carriage of Lithium batteries. Visit their website (<http://www.iata.org/whatwedo/cargo/dgr/Pages/lithium-batteries.aspx>) for more information and guidance on different situations, making sure the last approved versions are used.

Mitigating the risks posed by Lithium batteries: summary

Lithium battery thermal runaways can be caused by design / manufacturing quality / integration shortcomings or by inadequate compliance with a number of basic rules. The following principles should be adhered to in order to minimize the risk of Lithium battery fires and explosions:

- Ensure that Lithium cells/batteries shipped comply to international standards.

- Ensure that loads conform with ICAO / IATA labelling, packaging and handling recommendations.

- Ensure compliance to the Airbus Parts Catalogue when replacing batteries.

- Ensure that ground, flight and cabin crews are trained and passengers are aware of Lithium batteries specificities. ■

HOW TO MANAGE THE CONSEQUENCES OF A LITHIUM BATTERY FIRE

As detailed previously, proactive action by making passengers and airline personnel aware of the risks posed by Lithium batteries is preferable than reacting to a fire caused by a Lithium battery. Therefore knowing what to do in the unlikely event of a Lithium battery

fire is essential. The key principles to safely and efficiently tackling a Lithium battery fire, whether it is in the cabin of flight deck, being:

- Keep people away from the fire
- Minimize risks of fire propagation
- Apply specific firefighting principles.

Apply specific firefighting principles

Classical firefighting procedures and fire extinguishing means are not efficient to stop a lithium battery fire.

Halon can suppress open flames, but it is ineffective in addressing the source of fire. Use of water is the best option to allow cooling and limit the propagation to adjacent cells.



Fight the flames



Fight the heat

Once a lithium battery cell has ignited then the effort must concentrate on cooling the surrounding cells by use of water (or other non-alcoholic liquid) and preventing deterioration of the situation to avoid any fire propagation to the adjacent battery cells.

To this extent specific procedures that provide guidance on managing Lithium battery fires have recently been included for both cabin crew (in the CCOM) and flight crew (in the FCOM/QRH/FCTM).

“ Halon can suppress open flames, but it is ineffective in addressing the source of fire. Use of water is the best option to allow cooling and limit the propagation to adjacent cells. ”

“ In the cabin, do not try to pick up and attempt to move a burning device or a device that is emitting smoke. ”

(fig.8) Lithium battery fire CCOM procedure

Cabin crew procedures

Isolate the source of fire

Reacting to a Lithium battery fire in the cabin starts with isolating the source of fire. Indeed, a smoking battery may explode at any time, due to the highly exothermic thermal runaway. In the cabin, do not try to pick up and attempt to move a burning device or

a device that is emitting smoke. Prevent propagation by ensuring that no flammable material (fluids, gas, devices) are near the smoking battery. Also relocate passengers away from the burning or heating device.

Fight the fire according to specific procedures

Once the burning / heating device has been isolated, the fire itself needs to be addressed. To this end, three specific cabin crew procedures to

deal with Lithium batteries fires have been developed based on the FAA recommendations.

» Lithium battery fire procedure

This procedure (fig.8) proposes the use of Halon to extinguish open flames, and water (or a non-alcoholic liquid) to cool the device down. The recommendation is then to im-

merse the device in a suitable container (such as a waste bin, or standard galley container) to secure against thermal runaway (refer to the third step below).

LITHIUM BATTERY FIRE

Ident.: 09-020-00015205.0001001 / 28 JAN 14
Criteria: LR
Applicable to: ALL

The roles of the firefighter, assistant firefighter and communicator must be distributed according to the basic firefighting procedure.

In the case of PED or spare lithium battery fire in the cabin or when notified by the flight crew:

- **If there are flames:**
 FIREFIGHTING EQUIPMENT..... TAKE
Consider the use of a PBE and fire gloves.
 HALON EXTINGUISHER.....DISCHARGE
Halon extinguisher must be discharged to suppress the flames prior to cool down the PED or the Spare lithium battery.
- **When the flames are suppressed or If there are no flames:**
 ON PED or spare lithium battery.....POUR WATER OR NON-ALCOHOLIC LIQUID
The PED or Spare lithium batteries must be cooled down by pouring water or non-alcoholic Liquids
 STORAGE PROCEDURE AFTER A LITHIUM BATTERY FIRE APPLY

WARNING

- Do not attempt to pick up and move a smoking or burning device
- Do not cover the device or use ice to cool down the device. Ice or other materials insulate the device increasing the likelihood that additional battery cells will ignite.
- Do not use fire resistant burn bags to isolate burning lithium type batteries. Transferring a burning appliance into a burn bag may be extremely hazardous.

END OF PROC

» Overhead bin smoke/fire procedure

Lithium battery fires may sometimes not easily be identified, and considering the specific cases when fires have actually

occurred in service, the procedure for fire in the overhead compartment (fig.9) now considers as a base that

a Lithium battery powered device may be at the origin of the fire. Therefore the overhead bin smoke/ fire procedure now covers the use

of Halon and liquid to tackle the fire, and makes reference to the other two cabin crew procedures to address a Lithium battery fire.

(fig.9) Overhead bin smoke/ fire CCOM procedure

OVERHEAD BIN SMOKE/FIRE PROCEDURE

Ident.: 09-020-00004671.0001001 / 28 JAN 14
Criteria: LR
Applicable to: ALL

Smoke/fire in overhead bins may be caused by the contents i.e. electronic device, spare lithium battery) or electrical malfunction in the Passenger Service Unit (PSU). The firefighter, the assistant firefighter, the communicator and the support crewmembers must conduct their tasks simultaneously.

- **When smoke is coming from an overhead bin:**
 FIREFIGHTER AND ASSISTANT FIREFIGHTER DON
 PBE.....
 FIREFIGHTER
 FIRE EXTINGUISHER..... TAKE
Note: Consider the use of fire gloves.
 ASSISTANT FIREFIGHTER
 WATER OR NON-ALCOHOLIC LIQUID..... TAKE
Note: Water or non-alcoholic liquid is required if the fire involves lithium battery.
 SUPPORT CREWMEMBERS
 PASSENGERS..... RELOCATE
 COMMUNICATOR
 FLIGHT CREW..... NOTIFY IMMEDIATELY VIA INTERPHONE
 FIREFIGHTER
 OVERHEAD BIN..... CHECK FOR HEAT
Using the back of the hand, feel the overhead bin to determine the temperature and presence of fire.
 (*)OVERHEAD BIN..... OPEN SLIGHTLY
Enough to pass the nozzle of the fire extinguisher.

CAUTION Opening the overhead bin more than necessary can cause contamination of the cabin with smoke, and can result in smoke inhalation.

 (*)FIRE EXTINGUISHER DISCHARGE
Note: The fire extinguisher must be discharged into the overhead bin, away from the seat, to prevent debris from contaminating the cabin.
 (*)OVERHEAD BIN CLOSE AND LATCH
Continued on the following page

OVERHEAD BIN SMOKE/FIRE PROCEDURE (Cont'd)

FIREFIGHTING..... REPEAT AS NECESSARY
 (*)Repeat last three steps of the procedure, as necessary.

- **When the flames are suppressed:**
 FIREFIGHTER
 OVERHEAD BIN..... CHECK THE SOURCE OF FIRE
Note: The assistant firefighter must support the firefighter in the case of re-ignition by using fire extinguisher.
- **If source of smoke/fire is coming from a visible PED and/or Spare batteries:**
 FIREFIGHTER
 ON PED OR SPARE LITHIUM BATTERIES.....
 POUR WATER OR NON-ALCOHOLIC LIQUID
The PED or Spare lithium batteries must be cooled down by pouring water or non-alcoholic liquids.
- **If the source of smoke/fire is coming from an identified item:**
 FIREFIGHTER
 IDENTIFIED ITEM..... TAKE OUT
 ON IDENTIFIED ITEM..... POUR WATER OR NON-ALCOHOLIC LIQUID
The identified item must be cooled down by pouring water or non-alcoholic liquids.
- **If the source of smoke/fire is coming from a non-identified item:**
 FIREFIGHTER
 OVERHEAD BIN..... EMPTY WITH CAUTION
Note: Empty the overhead bin until the source of smoke/fire is identified.
 ON IDENTIFIED ITEM..... POUR WATER OR NON-ALCOHOLIC LIQUID
The identified item must be cooled down by pouring water or non-alcoholic liquids.
 STORAGE PROCEDURE AFTER A LITHIUM BATTERY FIRE APPLY
 END OF PROC

(fig.10)
Storage after a Lithium battery fire CCOM procedure

» **Storage procedure after a Lithium battery fire**

As referenced in the first step above, this procedure **(fig.10)** is called at the end of the two previous procedures. Once the fire has been contained and the device can be safely moved, this procedure recommends to place receptacle where the burning/heating device was immersed in a lavatory and

subject it to regular monitoring. The lavatory is proposed as it contains a means of smoke detection, but is also a location that can secure the device away from the passengers and provides waterproof floor designed to receive water in case of turbulent conditions.

STORAGE PROCEDURE AFTER A LITHIUM BATTERY FIRE	
Ident.: 09-020-00015206.0001001 / 28 JAN 14	
Criteria: LR	
Applicable to: ALL	
<ul style="list-style-type: none"> ● When the PED or the spare battery can be safely moved: 	
FIRE GLOVES.....	PUT ON
RECEPTACLE.....	TAKE
<i>Consider the use of any suitable empty receptacle (e.g. standard unit or lavatory waste bin ...)</i>	
RECEPTACLE.....	FILL WITH WATER OR NON-ALCOHOLIC LIQUID
PED OR SPARE BATTERY.....	IMMERSE
<i>Total immersion of the PED or the spare battery will prevent fire re-ignition.</i>	
RECEPTACLE.....	STORE INTO THE NEAREST LAVATORY
LAVATORY.....	SET AS INOPERATIVE
AFFECTED LAVATORY.....	MONITOR
<i>The affected lavatory must be regularly monitored for the remainder of the flight to ensure that the device remains immersed.</i>	
END OF PROC	

Flight crew procedure

More and more flying crews are taking advantage of the capabilities offered by Electronic Flight Bags (EFBs), the majority of which use Lithium batteries as a primary power source. But Lithium batteries may also enter a cockpit in the form of a flashlight, laptop, tablet, camera, mobile phone,... i.e. any Portable Electronic Devices (PEDs). With the aim to preventing a Lithium battery fire, the key is to ensure that the EFBs and other PEDs are not exposed to abuse conditions (i.e. dropped or damaged), and if damaged, not used until confirmed serviceable. However, if the feared situation occurs, flight crew procedures have been developed on the basis of key principles: Fly, Navigate, Communicate, with appropriate task sharing.

The philosophy of the Airbus “Smoke/Fire from Lithium battery” procedure **(fig.11)** is:

- One pilot needs to continue flying the aircraft, while the second pilot will address the detected fire. If necessary, transfer control. Usually the fire fighter is the one the closest to the fire.
- Establish communication with the cabin – a Lithium battery fire should be managed as a whole crew concern – to initiate the “Storage after a Lithium battery fire” procedure.
- Secure the safety of the flight crew: the Pilot Flying should don the oxygen mask, while the pilot that will tackle the fire should don the Portable Breathing Equipment (PBE).
- Use Halon to extinguish any open flames.

“ Flight crew procedures have been developed on the basis of key principles: Fly, Navigate, Communicate, with appropriate task sharing. ”

- Once there are no more open flames:
 - If it is not possible to remove the burning/heating device from flight deck, pour water or non-alcoholic liquid on the device to cool it down. Be aware of possible explosion. Tests completed by Airbus have confirmed that a small quantity of water aimed at the device is sufficient to cool it and mitigate the consequences of the thermal runaway.
 - If it is possible to move the device: transfer it to the cabin and use the Cabin Crew Lithium battery procedures to secure it, by immersion in water or non-alcoholic liquid. ■

SMOKE/FIRE FROM LITHIUM BATTERY	
If necessary, transfer control to the flight crew member seated on the opposite side of the fire	
CKPT/CAB COM.....	ESTABLISH STORAGE AFTER Li BAT FIRE cabin procedure.....
..... REQUEST INITIATION	
● If there are flames:	
CREW OXY MASK (PF).....	USE
SMOKE HOOD (PM).....	USE
HALON EXTINGUISHER.....	USE
● If there are no flames or when flames are extinguished:	
■ If not possible to remove device from the cockpit:	
WATER or NON-ALCOHOLIC LIQUID.....	POUR ON DEVICE
DEVICE.....	MONITOR
■ If possible to remove device from the cockpit:	
DEVICE.....	TRANSFER TO CABIN

(fig.11)
Smoke/fire from Lithium battery QRH procedure

? DID YOU KNOW _____

To know more about Lithium battery fires management in the cabin, and cabin safety issues in general, read our brochure “Getting to grips with cabin safety”, available on Airbus World.



Lithium batteries have existed for more than 20 years now and are widely used in all daily applications. This technology is extremely efficient and its range of applications is constantly expanding. Whilst fortunately events involving Lithium batteries are rare, and even rarer when occurring in flight, the risk of fire still exists. The specificities of Lithium batteries need therefore to be considered in all aspects of aircraft applications and managed correctly – whether carried as cargo, or installed as equipment in the flight deck or cabin, or just as part of the passengers carry-on baggage.

Article contributors include Joerg KLOCKGETHER and Dieter JUST.



Wake Vortices

All aircraft generate wake vortices, also known as wake turbulence, which continue to be evident far behind the generating aircraft. Another aircraft crossing this wake may feel a sharp and brief turbulence which can be strong under some circumstances. Let's review the specific characteristics of wake vortices' and how pilots should react in case of an encounter to ensure the safety of the flight.



CLAUDE LELAIE
Former Head
of Flight Test

Where do Wake Vortices come from?

All aircraft generate wake vortices, also known as wake turbulence. When an aircraft is flying, there is an increase in pressure below the wing and a depression on the top of the aerofoil. Therefore, at the tip of the wing, there is a differential pressure that triggers the roll up of the airflow aft of the wing.

Limited swirls exist also for the same reason at the tips of the flaps. Behind the aircraft all these small vortices mix together and roll up into two main vortices turning in opposite directions, clockwise behind the left wing (seen from behind) and anti-clockwise behind the right one **(fig.1)**.

(fig.1)
Development of wingtip vortices

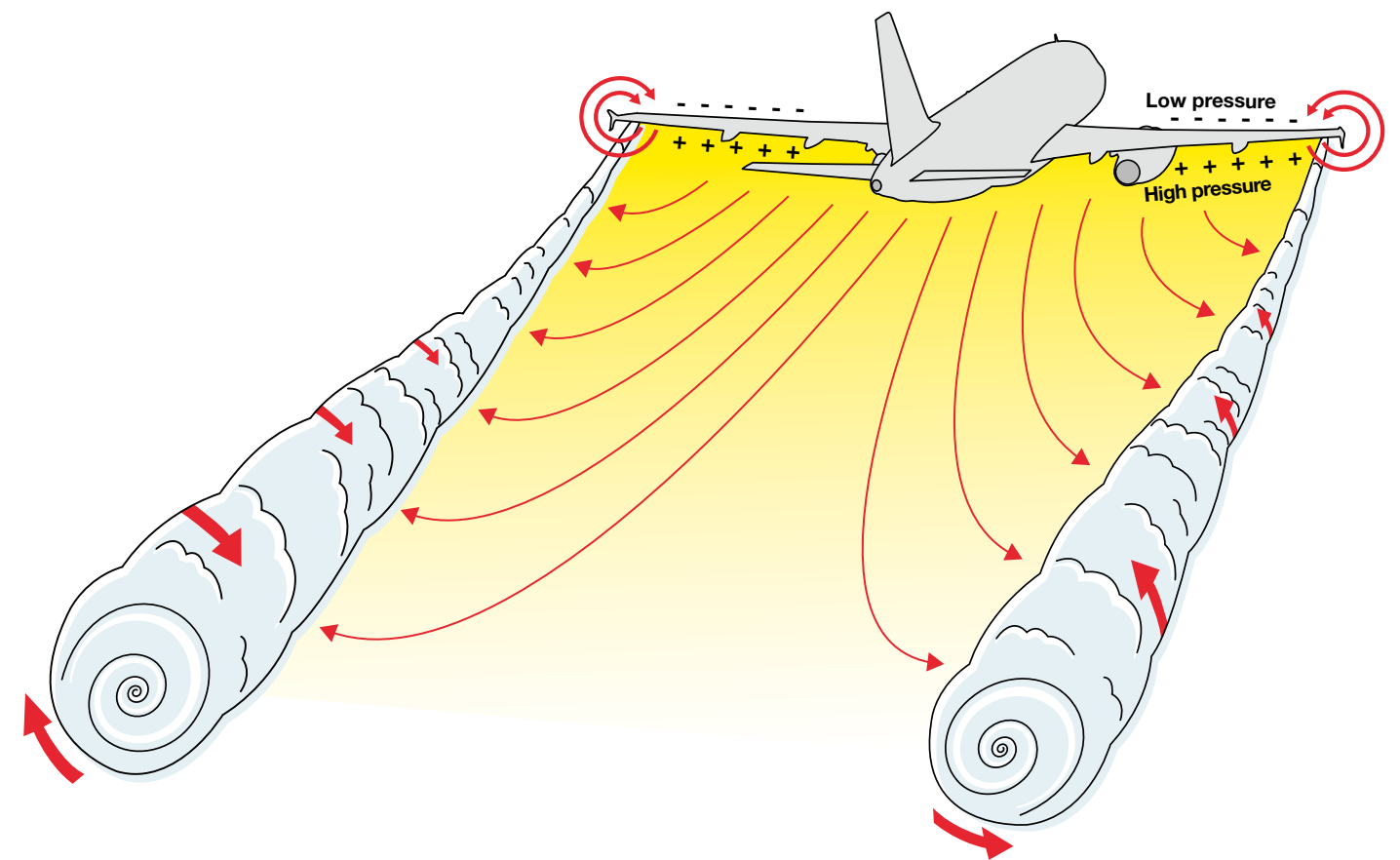

What are the characteristics of wake vortices?

Size: The active part of a vortex has a very small radius, not more than a few meters. However, there is a lot of energy due to the high rotation speed of the air.

Descent rate: In calm air, a wake vortex descends slowly. As an order of

magnitude, in cruise, it could be 1000 ft below and behind the generating aircraft at a range of around 15 NM. Then, when far away from the generator, the rate of descent becomes very small. In approach, the descent is usually limited to around 700 ft.

“ The decay is much faster in ground effect. ”

However, depending on weather conditions the descent rate may vary significantly and may even be very small. One of the key factors affecting this descent is the variation of the temperature with the altitude. A temperature inversion limits the rate of descent.

Decay rate: One important parameter of a wake vortex is the decay of its strength with time. The decay rate varies slightly from one aircraft type to another. Unfortunately, in calm air, due to low external interference, it is rather low and this is why the separation

Parameters affecting the wake vortex

Aircraft weight: Wake vortex strength increases with the weight of the aircraft. This is why today the ICAO aircraft classification is based on the MTOW. However, such an approach is a simplification as other parameters also affect the strength at the separation distance.

Wing characteristics: The wing shape and the load distribution affect the wake vortex characteristics, mainly through the decay rate.

A smaller wing span increases the decay rate. Therefore, for a given “vortex generator” or “leader” aircraft weight and at the same distance, vortex encounters are less severe behind an aircraft having a smaller wingspan.

between aircraft needs to be so large.

Ground effect: When the aircraft is close to the ground, less than a wingspan, the two vortices tend to drift out from the centre line, each towards its own side, at a speed of around 2 to 3 kt. It is this phenomenon, when associated with a light crosswind component that tends to “hold” the “into wind” vortex roughly on the centreline, whilst the “downwind” vortex moves away.

Due to this phenomenon, the decay is much faster in ground effect.

It has also been demonstrated that aircraft having a high inboard loading (higher deflection of the flaps close to the fuselage as an example) have a faster decay of their vortices.

Weather conditions: The weather conditions play a major role in wake vortex development and decay. In the case of heavy turbulence, a vortex will dissipate very quickly and there is no risk for the “follower” aircraft. Strong winds are associated with turbulence and will also contribute to a rapid dissipation.

Calm weather creates the most critical situation as the strength decreases slowly and the vortex effect may be felt far behind the vortex generating aircraft. Today, in order to be safe, all separations assume that the aircraft are flying in perfectly calm conditions.

Encountering a wake vortex

DEFINITIONS

When an aircraft enters in the vortex of another aircraft, the “manoeuvre” is called an encounter. The aircraft emitting the vortex is called the generator and the one experiencing it, the follower.

How likely is an encounter?

It is not possible to implement navigation procedures such that the probability of an encounter is zero. To give an example, during the Airbus wake vortex flight tests,

in cruise, A319 vortices were identified at a range of 42 NM, thanks to the contrails. An encounter with such a vortex is obviously very weak but it exists and it

would have been a bit stronger behind a Heavy. It is also common to have, in the initial approach phase, encounters at distances well above the ICAO minimum separations. The ICAO separations have not been set to avoid all encounters but to prevent unsafe encounters. Avoiding all encounters would require very

significant separations and dramatically limit the traffic on all airports and airways without significantly improving safety. It is also to be noted that statistics show that the probability of injury to passengers and crew is about five times greater in turbulence due to weather, than with a wake vortex encounter.

How does it feel to encounter a wake vortex?

In most cases the effect of the vortex is mainly felt in roll. We will consider here the case of an aircraft entering laterally in a vortex, which is the most frequent situation. Let’s assume that a follower aircraft is entering the right vortex of the leader aircraft from its right side. Seen from behind, this vortex is rotating anti-clockwise. When the left wing of the follower first enters the vortex, there is on this wing a local angle of attack increase and therefore the lift becomes higher than on the right wing. The initial roll motion is therefore to the right. Then, when the aircraft is in the middle

of the vortex, it will be subjected to the full strength of the vortex and roll in the same direction as the vortex, to the left (fig.2). This is the main rolling motion that creates the strongest roll acceleration.

As a conclusion, the typical signature of a severe encounter is an initial small roll in one direction followed by a much more significant roll in the other sense.

When in cruise, this roll motion may be associated with significant load factor variations.

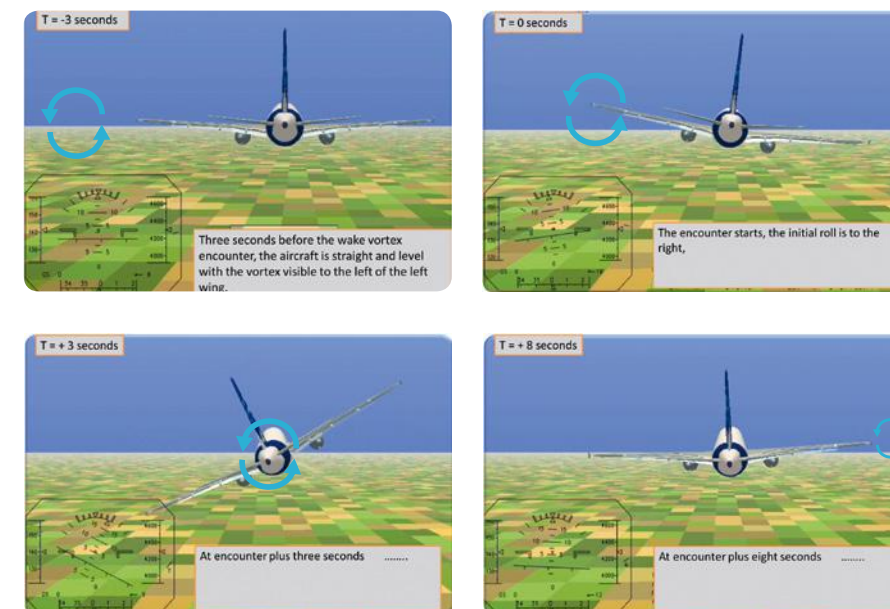

“ The ICAO separations have not been set to avoid all encounters but to prevent unsafe encounters. ”

(fig.2) Aircraft behaviour in a wake vortex encounter (The aircraft bank angle is voluntarily exaggerated on the figure)

“ The typical signature of a severe encounter is an initial small roll in one direction followed by a much more significant roll in the other sense. ”

Effect on the trajectory of the follower

To experience a severe roll encounter, it is necessary for the follower to have a trajectory with a small closing angle with the vortex. However, if this angle is too small, the aircraft will be smoothly “ejected” from the vortex (due to the initial roll in the example above).

When perpendicular, there will be no rotation, and any encounter will be a very brief but sharp turbulence effect. To experience a severe encounter, the most critical angle between the trajectory of the follower and the vortex is around 10 degrees.

“ Calm weather creates the most critical situation as the strength decreases slowly and the vortex effect may be felt far behind the vortex generating aircraft. ”

Severity of the encounters

The authorized separations are such that the severity of the encounters does not create an unsafe control situation. When the aircraft is not in ground effect, the order of magnitude of the bank angle for a severe encounter on the approach is around 20°. But

when in ground effect, as explained above, the decay is much faster and the worldwide experience during many years shows that the bank angle achieved is much lower and does not lead to a risk of touching the ground with the wingtip.

Duration of an encounter

A severe encounter, as described above, where the trajectories of both aircraft have an angle around 10 degrees, typically lasts around 4 to 6 seconds.

with the flight mechanics equations, it has been demonstrated during Airbus flight tests that the stabilization of a large aircraft inside a vortex can only be obtained by voluntarily establishing a large sideslip angle. As airliners do not and should not fly with large sideslip angles, they cannot remain in a vortex. Therefore, a vortex cannot be the cause of long duration turbulence.

It is not possible to remain for a long time in a severe vortex as the rotating airflow on the wing and on the fin, eject the aircraft from the vortex. In line

Operational procedures

General procedure increases

Considering the way the vortex is acting on the aircraft as explained previously, if the pilot reacts at the first roll motion, to the right in the example given, he will correct by rolling to the left. When in the core of the vortex, the main roll motion to the left will then be amplified by this initial piloting action. The result will be a final bank angle greater than if the pilot would not have moved the controls.

clearly show that pilot action does not improve the situation.

In addition, in-flight incidents have demonstrated that the pilot inputs may exacerbate the unusual attitude situation with rapid roll control reversals carried out in an “out of phase” manner.

In the case of a severe encounter the autopilot may disconnect automatically, but in all other cases, it will be able to counter properly the roll and pitch motions generated by the vortex.

This has also been demonstrated during the Airbus flight tests. Most of the encounters have been performed stick free, but several hundred were carried out with the pilot trying to minimize the bank angle. The results

For these reasons, the best procedure in case of encounter is:

RELEASE THE CONTROLS

Do not voluntarily disconnect the autopilot
 If the autopilot is disconnected, before any reaction, wait for a reasonable stabilization of the aircraft, then:

- Roll wings level.
- Re-establish the initial cruise level or the standard climb or descent trajectory.

Use of rudder warning

A large deflection of the rudder creates a very important lateral acceleration that may well surprise the pilot. It could lead to a reaction with a deflection to the other side. This could then give rise to very large forces on the fin that may exceed the structural resistance. An

accident has already occurred for this reason. Some recent aircraft types are protected thanks to their fly-by-wire systems, but anyway, any use of the rudder does not reduce the severity of the encounter nor does it improve the ease of recovery. Therefore:



Lateral offset

If two aircraft are flying exactly on the same track, one being 1000 ft below the other, in the same or opposite direction, and if there is no cross wind, there is a risk of encounter with a vortex for the lower aircraft. In this case, it is possible to reduce the risk by using a lateral offset.

not a guarantee that an encounter will be avoided (except if the vortices are clearly visible by contrails).

In case of cross wind, if the two aircraft are flying exactly on the same track, the wind will move the vortices out of the track of the lower aircraft whilst they are descending. In this situation, if a lateral offset is decided for other reasons than wake vortex avoidance, an offset upwind by the follower is to be preferred, since a downwind one may potentially create an encounter.

However, most of the time, it is difficult to know whether the other aircraft is flying with or without a small relative offset due to the lack of angular precision of the TCAS. Therefore, this offset is

Final approach

During the final approach, it has sometimes been suggested to maintain a trajectory slightly above the glide slope. This is not a satisfactory procedure for transport aircraft for several reasons:

is already, today, the main cause of accidents and such a technique would only increase that risk.

As a conclusion, a transport aircraft should not deviate from the standard approach slope to avoid a risk of encounter. However, for light aircraft, with low approach speed, approaching on a long runway, it is an acceptable procedure to perform a high approach and a long landing, targeting a touch down point after that of the previous aircraft.

- When established in descent on the standard approach slope, as the vortex is descending, there is little risk of encountering the vortices of the previous aircraft, except possibly when reaching the area of the ground effect. However, this possibility has not led to an unsafe situation (no accident in ground effect recorded on transport aircraft with standard separations).

It is to be noted that, when on an approach, there is no risk of encounter with the vortices of an aircraft taking-off on the same runway as a vortex will only move backward due to the wind effect. Such a vortex will have a very limited strength, and in the case of a strong headwind may even be dissipated completely. However, with crossing runways, depending on their geometry,

- If the aircraft is flown too high above the threshold to avoid a possible encounter, it will lead to a long landing and therefore significantly increase the risk of runway excursion. It is well known that runway excursion

and with inappropriate procedures, it may be possible that, very close to the ground, a landing aircraft enters the vortex of an aircraft which took-off on

Departure

During the take-off phase, other than time separation, no avoidance procedure is applicable as the manoeuvre is dictated by characteristic speeds V1, Vr, V2, determined by the weight, the weather conditions and the runway. The time separations given for some aircraft types ensure that possible encounters after take-off remain controllable. When no time separation is given by ICAO rules, the separation is decided by the ATC to

another runway. Pilots on the approach need to maintain a general vigilance and awareness, especially with calm wind conditions.

obtain a minimum radar separation, depending on the departure trajectory and long experience has demonstrated an acceptable level of safety.

For a light aircraft taking-off from a long runway behind a transport aircraft, it is recommended to choose the departure point in order to achieve a trajectory well above the preceding aircraft.

Separations

ICAO rules

Almost everywhere in the world the separations comply with the ICAO rules.

Classifications: Three categories of aircraft are defined according to the MTOW:

- Heavy (H):** above 136 tons.
- Medium (M):** between 7 and 136 tons.
- Light (L):** below 7 tons.

In addition, despite being classified as Heavy, the A380 is known as Super (S), and subjected to increased separations in approach, behind.

Cruise: In cruise, the separations are identical for all aircraft types:

- Horizontally:** 5 NM.
- Vertically:** 1000 ft.

Approach: On approach, the separations depend on the leader and the follower classification. The table below gives the separations for the various pairs on the same runway. They apply also to operations on different parallel runways if they are separated laterally by less than 760 m. To be noted that the A380 separations are not in the ICAO recommendations (PANS-ATM), but in a provisional State Letter published by ICAO in 2008.

		Follower			
		S	H	M	L
Leader	S		6 NM	7 NM	8 NM
	H		4 NM	5 NM	6 NM
	M				5 NM
	L				

Other rules: The ICAO rules are used worldwide except in two Countries, USA and UK. These two Countries apply a different classification with different weight limits and separations.

RECAT (Re-categorization).

Principles of the re-categorization: The target of the re-categorization is to reduce the separations on approach and for departure between some aircraft pairs, without degradation of the safety levels, in order to improve the landing capacity of a given runway or runway couple.

The first step is called RECAT 1. All the aircraft are placed in 6 categories

from A to F, A being the larger aircraft category. The principle is to divide the Heavies and the Medium each in 2 categories. As an example, today, the separations between Heavies are established for the worst case that is the smaller Heavy behind the bigger. However, if this bigger Heavy follows the smallest, common sense indicates that a reduction of separation is possible without any impact on the safety level (fig.3). Similarly, the separation may be reduced between two big Heavies or two small Heavies. The same principles apply to the Medium category. The target is that no situation should be worse than that which exists today with ICAO separations.

(fig.3) Toward a reduction of aircraft separation minima to aircraft categories

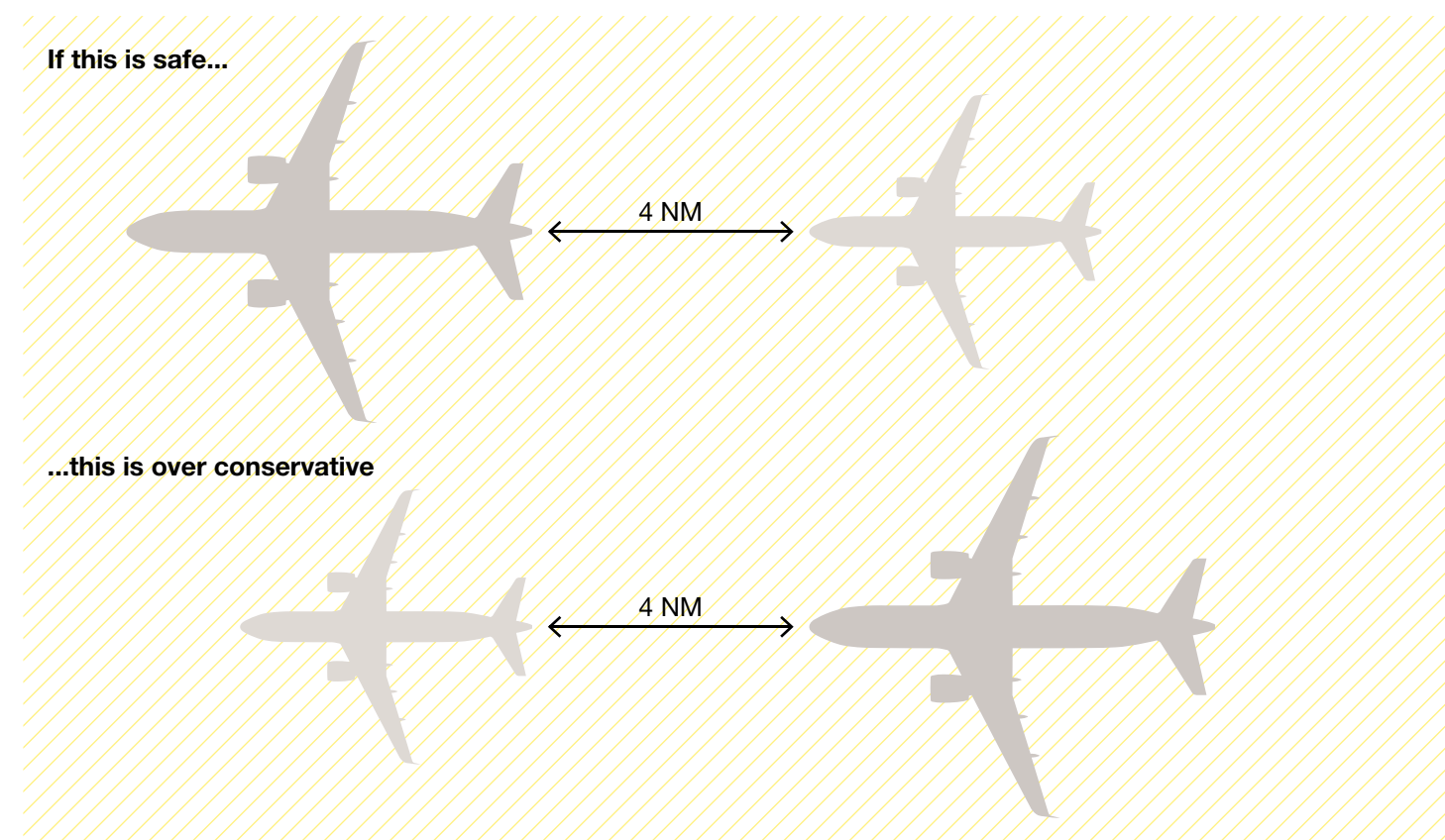

RECAT 1 FAA: The FAA decided to reclassify the aircraft by MTOW and wingspan. The RECAT FAA is implemented on several US airports.

RECAT 1 EU: It appeared that the RECAT FAA approach was giving few benefits to the European airports due to the differences in the airlines fleets on both sides of the Atlantic. A RECAT EU was therefore developed. It takes into consideration not only the strength of the wake vortex of the leader aircraft, but also the resistance of the follower. The encounter tests performed by Airbus allowed validating some models used for the computations.

The RECAT 1 EU has also 6 categories:

- A - Super Heavy:** Including A380 and An124.
- B - Upper Heavy:** MTOW above 100 tons and wingspan between 52 m and 72 m.
- C - Lower Heavy:** MTOW above 100 tons and wingspan below 52 m
- D - Upper Medium:** MTOW between 15 and 100 tons and wingspan above 32 m.
- E - Lower Medium:** MTOW between 15 and 100 tons and wing span below 32 m
- F - Light:** MTOW below 15 tons.

The separations are as follows:

		Follower					
		Super Heavy	Upper Heavy	Lower Heavy	Upper Medium	Lower Medium	Light
Leader	Super Heavy	3 NM	4 NM	5 NM	5 NM	6 NM	8 NM
	Upper Heavy		3 NM	4 NM	4 NM	5 NM	7 NM
	Lower Heavy			3 NM	3 NM	4 NM	6 NM
	Upper Medium						5 NM
	Lower Medium						4 NM
	Light						3 NM

The RECAT EU was approved by EASA end 2014. The implementation is planned at Paris-Charles-de-Gaulle airport in February 2016 and it will also be implemented in some airports worldwide.

It is to be noted that this implementation is not intended to be mandatory and only the most important European airports will use it, the other ones will keep the ICAO separations.

RECAT 2 and RECAT 3: The RECAT 2 is also called “pair-wise”, with a separation that takes into consideration the leader and the follower types, possibly by groups of aircraft. It will be implemented in the coming years. ■

The separations are not meant to avoid all encounters but to prevent unsafe ones. In very calm air, wake vortices encounters may lead to strong turbulence with significant bank angle and possibly some load factor when at high altitude.

Remember: Release the Controls and DO NOT use Rudder.





A320 Family Aircraft configuration

SOFTWARE HAVE THEIR OWN PART TOO!

With the introduction of a data loading function on A320 Family aircraft Flight Control and Auto Flight computers, managing the aircraft configuration entered a new dimension. Flying a certified aircraft now requires understanding not only hardware Part Numbers, but also less immediately visible operational software ones.



UWE EGGERLING
Senior Director Safety Engineering and Maintenance



ALEXANDRE LAGU
Flight control systems Senior engineer

FIELD LOADABLE SOFTWARE: WHAT IS IT ABOUT?

Field Loadable Software (FLS) associated with Data Loadable Units (DLU), were originally introduced to facilitate the evolution of standards and the management of spares. To do so, these computers provide an upgraded hardware that can accommodate different versions of operational software, i.e. different

standards. Updating the standard of a FLS can thus be done without removing the hardware itself from aircraft. Indeed, it simply consists in uploading the new version of the operational software from a media disk to the same hardware, either directly on-board or using a portable data loader.

Are all A320 Family aircraft concerned?

Field Loadable Software started to be introduced progressively on the A320 Family around six years ago. In practice, on the existing fleet, some aircraft have it (either from delivery or via Service Bulletin), others don't. However, even the non-equipped aircraft can accommodate a DLU

hardware without using the aircraft data loading function. In that case, the hardware needs to be fitted upstream in a repair shop, with the adequate operational software version. The DLU loaded with the relevant Field Loadable Software standard then behaves as a non-loadable computer.

In 2009, a new data loading function was introduced on A320 Family aircraft Flight Control and Auto Flight systems computers. Although the operational improvements brought by Field Loadable Software (FLS) are widely appreciated, experience gained with them highlights a potential for aircraft configuration mismanagement as a result of improper software part number uploading in the computers.

In fact, the use of data loadable computers requires to manage not only hardware Part Numbers (PN), but also software PN and their combinations. This evolution calls for a change in mind sets and practices to properly manage FLS and data loadable computers configurations and in turn, the aircraft configuration.

This article will highlight the underlying safety aspects of an incorrect use of FLS and review how to best prevent it.

“ On the existing A320 Family fleet, some aircraft have FLS, others don't. Yet, all aircraft can accommodate DLUs. ”

What does the data loading function change in practice?

If a DLU loaded with the appropriate standard behaves exactly as a non-loadable computer, whether it is installed on an aircraft with the data loading function or not, the use of this new DLU introduces a major change in terms of spares and aircraft configuration management: the emergence of

a new, intangible and not immediately visible dimension. Indeed, with the disconnection between hardware and operational software introduced by Data Loadable Units, the aircraft configuration consists of physical parts PN as well as operational software PN.

“ A quick glance at the hardware installed cannot tell everything about the FLS standard, and in turn, the actual aircraft configuration. ”

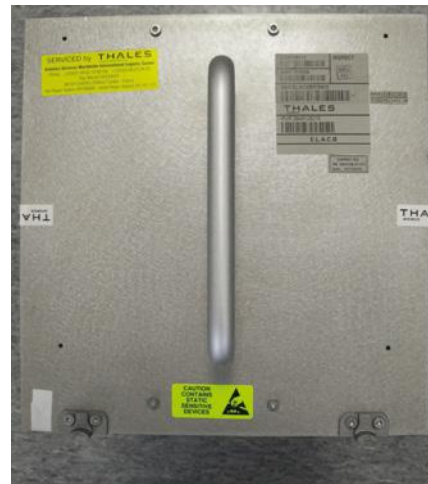

Non-DL ELAC



DL ELAC

In practice, it means that a quick glance at the hardware installed is not sufficient to identify the FLS standard, and in turn, the actual aircraft configuration. ■

WHAT IF THE AIRCRAFT FLIES WITH INAPPROPRIATE OPERATIONAL SOFTWARE? OR WHEN INAPPROPRIATE OPERATIONAL SOFTWARE CAN LEAD TO A NON-CERTIFIED AIRCRAFT CONFIGURATION...

No one would install an incorrect hardware PN on the aircraft as the aircraft would then be in a non-certified condition, with all the potential safety consequences it could have. Flying with incorrect operational software comes to the same thing!

operating such configurations, whether immediate or not, could not be studied and tested because exploring them falls de facto outside of the design studies. However, they do exist and can take on a potential significant safety dimension.

Indeed, uploading an operational software into a hardware which is not supposed to receive it, leads to a non-certified aircraft configuration. This implies that the consequences of

The cases that were observed in service are good examples to reveal that consequences are varied and may actually impair safety in very different ways.

Case 1: Excessive structural loads - unknown structural fatigue

Sharklet aircraft include a new Load Alleviation Function (LAF) that allows to limit wing loads. This function is key to ensure that wing loads remain within certification requirements. Fitting a Sharklet aircraft with a pre-Sharklet ELAC (Elevator and Aileron Computer) and/or SEC (Spoiler & Elevator Computer) standard leads to

losing this LAF function, thus exposing the wing to non-anticipated and studied loads. If the consequences cannot be detected immediately, such non-certified configuration leads to structural loads and ultimately structural fatigue that have not been studied as such, but could ultimately result in safety concerns.

Case 2: Falsely relying on a safety enhancement not implemented on the aircraft

In order to reduce the likelihood of tail strikes or hard landings, new ELAC standards were developed with an improved transition flare law to ground law. Flying with an aircraft supposed to be fitted with these new computers and actually fitted with an ELAC standard prior to these improvements leads to a situation where pilots believe they benefit from these improvements whereas they actually don't. It is like driving a car believing it is equipped

with ABS system whereas it does not have the function.

Similarly, ROPS (Runway Overrun Protection System) is only available with the latest loadable FAC (Flight Augmentation Computer) standard. Installing an older software on a ROPS-capable aircraft would lead to lose this safety enhancement function and the crew would not be aware of it.



Case 3: Improper surfaces control and unexpected aircraft behavior

On Sharklet aircraft, in case Sharklet capable and non-Sharklet capable FLS are mistakenly mixed (knowing that this is a non-allowed and non-certified configuration), the behaviour and control of the aircraft might be impaired. Depending on the type of DLU concerned, possible consequences are:

- Mix of Sharklet capable and non-Sharklet capable ELAC/SEC Spoiler, Aileron and/or Elevator Surface actuator orders and monitoring provided by each ELAC/SEC might be different from one actuator to the other (as controlled by different units).
This may result in:
 - Force fighting in case of elevator double pressurisation (might lead to structural defect and/or Aircraft unexpected behaviour)
- Left and right Aileron surfaces synchronisation not properly applied as expected (might lead to Aircraft unexpected behaviour).
- Mix of Sharklet capable and non-Sharklet capable FAC
Installing a non-Sharklet capable FAC on a Sharklet aircraft may lead to erroneous characteristic speeds computation, which, in turn, may affect safety margins against the stall speed.

These cases are not an exhaustive list of the safety related consequences that may result from an erroneous combination of a DLU hardware loaded with the undesirable operational software standard. Some of the effects described are potential effects based on a purely theoretical analysis since these configurations have never been tested. However, unexplored safety related consequences does not mean no safety consequences!

With this in mind, the key question is: how to avoid installing a Data Loadable Unit with an inadequate FLS standard? ■

? DID YOU KNOW

ISI (In-Service Information) Ref. 27.93.00001 “ELAC mixability and interchangeability matrices” details how to manage data loadable units and associated Part Numbers. This document can be found on Airbus World.

PREVENTION: HOW TO AVOID INSTALLING A DATA LOADABLE UNIT WITH AN INADEQUATE OPERATIONAL SOFTWARE STANDARD?

In view of the potential operational consequences described earlier, Operators need to be cautious with FLS and DLUs management in order to ensure their aircraft are operated in a certified

“ Unexplored safety related consequences does not mean no safety consequences. ”

configuration at all time. Prevention starts with a good awareness of the most common factors that can contribute to having a DLU loaded with an undesirable operational software.

The investigation into reported events of improper operational software uploaded into Data Loadable Units highlighted a variety of initial contributing factors. Yet, they all have in common a major step being overlooked in the computer removal/installation AMM procedure: operational software identification through a LRU IDENTIFICATION check (LRU stands for Line Replaceable Unit)!

When operating FLS, strict adherence to all of the steps detailed in the AMM removal/installation tasks, and the LRU IDENTIFICATION step in particular, is the foundation of a good aircraft configuration management.

In more detail, investigation results highlighted that installing a DLU loaded with inappropriate software often results from the combination of being convinced to have the correct computer although not having it, and not taking the time to perform the procedure correctly, especially the operational software identification

step requested in the AMM installation and uploading tasks.

Being convinced of having installed the correct FLS standard although not having it, can in turn come from different reasons, such as:

- not having realized that the DLUs consist of two distinct parts, namely a hardware one and a software one, bearing 2 distinct Part Numbers and 2 FINs (Functional Item Number),
- being excessively confident in the shop that delivers the parts to be installed (the DLU received from the shop might not be loaded with the relevant operational software, i.e. the one that matches the actual aircraft configuration),
- relying on the spot on an old habit where a quick external glance at physical parts and their labels was sufficient to tell the computer standard.

Using existing safety barriers



As explained earlier, the introduction of Field Loadable Software comes with a change in philosophy and the emergence of a new intangible dimension in aircraft

configuration management. In contrast to hardware parts, operational software are always hosted. They are the invisible ones, behind the scene.

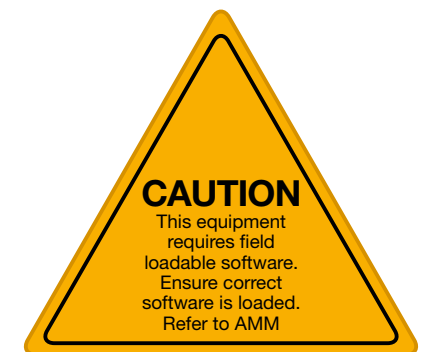

Concerning the parts managed by the shop, the disconnection between the hardware and the operational software for DLUs also implied switching from a unique computer FIN integrating both the hardware and software parts, to two distinct FINs corresponding respectively to the hardware PN and the operational software PN. In some airlines though, the spare parts supply chain management tool remained unchanged and does not accommodate two different FINs for a single FLS computer. This limitation

induces difficulties to ensure that the computer delivered is loaded with the appropriate operational software version.

In any case, an ultimate safety barrier was developed and included into the AMM to prevent the installation of improper operational software onto the aircraft: operational software identification via LRU IDENTIFICATION action and cross check of that information with the PN displayed on the media disk **(fig.1)**.

(fig.1)
Preventing the installation of an improper ELAC operational software onto the aircraft thanks to the AMM

4. Procedure
Subtask 27-93-00-280-052-A
A. Do a check of the reference of the software loaded in the ELAC

NOTE: This procedure is for the ELAC1. For the ELAC2, use the indications between the parentheses.

(1) Do the procedure to get access to the SYSTEM REPORT/TEST F/CTL page (Ref. AMM TASK 31-32-00-860-006).

ACTION	RESULT
1. Push the line key adjacent to the EFCS 1(2) indication.	The EFCS 1(2) menu page comes into view.
2. Push the line key adjacent to the LRU IDENTIFICATION indication.	The LRU IDENTIFICATION page comes into view.

(2) Make sure that the P/N of the ELAC shown on the LRU IDENTIFICATION page is the same as the P/N on the media disk.

(a) If the P/N of the ELAC shown on the LRU IDENTIFICATION page is different from the P/N on the media disk, replace the ELAC.

NOTE: If the two ELACs were not loaded with the same software, make sure that the configuration of the ELAC1/ELAC2 is a permitted configuration.

Computer removal & installation is usually performed in line maintenance. In practice, it may for example mean being under operational pressure to keep the aircraft on schedule. However, performing this check of the software reference between the one

displayed in the cockpit, on the LRU IDENTIFICATION page, against the one showed on the media disk is the only way to detect any discrepancy whatever its origin. Indeed, as mentioned earlier, a quick look at the DLU hardware can only tell part of the story.

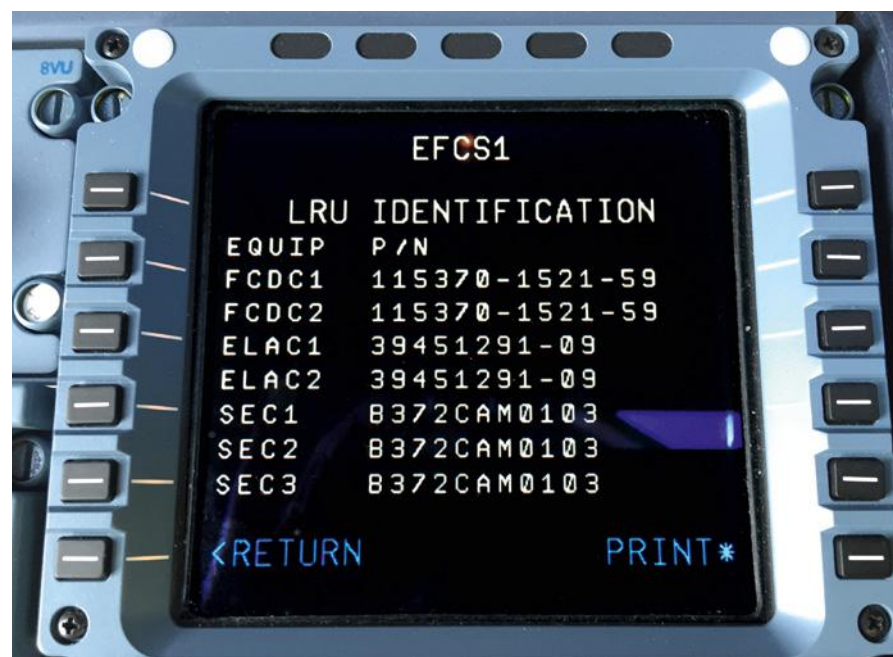

Operational software identification (LRU IDENTIFICATION) is the ultimate safety barrier to prevent inappropriate FLS and aircraft configurations.

Further enhancing prevention...

The in-depth analysis of reported events allowed for better understanding where problems originated from, and thus for devising ways forward.

As of today, the available prevention measures include:

- The improvement of the IPC to include explicit content and reinforce awareness on FLS **(fig.2)**.
- The improvement of the ISI (In-Service Information) documentation as a support for your fleet management. This document offers a good overview of existing certified configurations by explicitly explaining the hardware PN & operational software PN combination compatibility with the aircraft configuration. This advice is provided on the understanding that an ISI is not an approved instruction; therefore once a configuration is identified by this means, the IPC must be checked in order to confirm that it is a certified one indeed.
- The introduction in the Field Loadable Software training on A320 Family aircraft, of more details on the recommended uploading procedure, as well as a reminder of these DLUs specificity compared to earlier standards of computers.

03C 103	3945129100	ELAC-ELEVATOR AILERON COMPUTER ELAC B-DL HARDWARE HAS P/N 3945129100. IT IS USED FOR DATA-LOADABLE HARDWARE PART NUMBER WITHOUT ANY INFORMATION REGARDING THE OPERATION REGARDING THE OPERATIONAL SOFTWARE LOADED. DATA-LOADABLE ELAC PN 3945129100 INTERCHANGEABILITY AND MIXABILITY CONDITIONS DEPEND ON THE OPERATIONAL SOFTWARE LOADED. SEE 27-93-34-01A 001K FOR DET	2CE1, 2CE2	002
---------	------------	---	------------	-----

(fig.2)
The IPC raises awareness on FLS

Going further, Airbus aims at facilitating the visual distinction of the hardware between the ones including the data loading function and the others. To this end, work is already ongoing in order to define and develop a new label that will be placed onto each DLU. This reinforced attention getter will aim at improving the visual identification of DLUs and thus, reminding the need to check the operational software PN. ■



For those who have already experienced losing one of their favourite functionalities on their computer, smartphone or tablet because a new version of operating system had been developed and not yet updated on it, it is an unpleasant experience. When it comes to a Flight Control or Auto Flight computer loaded with a wrong operational software version, it can be far worse since it can affect safety. No doubt it is worth the very limited time and effort of a LRU IDENTIFICATION!

ARTICLES PUBLISHED IN PREVIOUS 'SAFETY FIRST' ISSUES

Issue 20

July 2015

- Control your speed... during climb
- Lateral runway excursions upon landing
- Fuel monitoring on A320 Family aircraft
- High-altitude manual flying

Issue 17

January 2014

- Airbus Brake Testing
- Hard Landing, a Case Study for Crews and Maintenance Personnel
- Aircraft Protection during Washing and Painting
- Flight Data Analysis (FDA), a Predictive Tool for Safety Management System (SMS)
- Flying a Go-Around, Managing Energy

Issue 14

July 2012

- Thrust Reverser Selection means Full-Stop
- Transient Loss of Communication due to Jammed Push-To-Talk A320 and A330/A340 Families
- **A380:** Development of the Flight Controls - Part 2
- Preventing Fan Cowling Loss
- Do not forget that you are not alone in Maintenance

Issue 19

January 2015

- Tidy cockpit for safe flight
- Landing on contaminated runways
- Understanding weight & balance
- Wind shear: an invisible enemy to pilots?

Issue 16

July 2013

- **Performance Based Navigation:** RNP and RNP AR Approaches
- **Atlantic Airways:** Introduction of RNP AR 0.1 Operations
- Flight Crews and De-Icing Personnel – Working together in Temporary Teamwork for safe Skies
- Low Speed Rejected Take-Off upon Engine Failure
- Late Changes before Departure

Issue 13

January 2012

- A320 Family / A330 Prevention and Handling of Dual Bleed Loss
- The Fuel Penalty Factor
- The Airbus TCAS Alert Prevention (TCAP)
- **A380:** Development of the Flight Controls - Part 1
- Facing the Reality of everyday Maintenance Operations

Issue 18

July 2014

- Control your speed... at take-off
- Safe operations with composite aircraft
- Learning from the evidence
- A320 Family cargo Containers/ pallets movement
- Parts Departing from Aircraft (PDA)

Issue 15

January 2013

- The Golden Rules for Pilots moving from PNF to PM
- Airbus Crosswind Development and Certification
- The SMOKE/FUMES/AVNCS SMOKE Procedure
- Post-Maintenance Foreign Objects Damage (FOD) Prevention
- **Corrosion:** A Potential Safety Issue

Issue 12

July 2011

- Airbus New Operational Landing Distances
- The Go Around Procedure
- The Circling Approach
- VMU Tests on A380
- Automatic Landings in Daily Operation

Issue 11

January 2011

- What is Stall? How a Pilot Should React in Front of a Stall Situation
- Minimum Control Speed Tests on A380
- Radio Altimeter Erroneous Values
- Automatic NAV Engagement at Go Around

Issue 8

July 2009

- The Runway Overrun Prevention System
- The Take-Off Securing Function
- **Computer Mixability:** An Important Function
- Fuel Spills During Refueling Operations

Issue 5

December 2007

- New CFIT Event During Non Precision Approach
- **A320:** Tail Strike at Take-Off?
- Unreliable Speed
- Compliance to Operational Procedures
- The Future Air Navigation System FANS B

Issue 2

September 2005

- Tailpipe or Engine Fire
- Managing Severe Turbulence
- Airbus Pilot Transition (ATP)
- Runway Excursions at Take-Off

Issue 10

August 2010

- **A380:** Flutter Tests
- **Operational Landing Distances:** A New Standard for In-flight Landing Distance Assessment
- Go Around Handling
- **A320:** Landing Gear Downlock
- Situation Awareness and Decision Making

Issue 7

February 2009

- **Airbus AP/FD TCAS Mode:** A New Step Towards Safety Improvement
- Braking System Cross Connections
- Upset Recovery Training Aid, Revision 2
- Fuel Pumps Left in OFF Position
- **A320:** Avoiding Dual Bleed Loss

Issue 4

June 2007

- Operations Engineering Bulletin Reminder Function
- Avoiding High Speed Rejected Take-Offs Due to EGT Limit Exceedance
- Do you Know your ATC/TCAS Panel?
- Managing Hailstorms
- Introducing the Maintenance Briefing Notes
- **A320:** Dual hydraulic Loss
- Terrain Awareness and Warning Systems Operations Based on GPS Data

Issue 1

January 2005

- Go Arounds in Addis-Ababa due to VOR Reception Problems
- The Importance of the Pre-flight Flight Control Check
- **A320:** In-flight Thrust Reverser Deployment
- Airbus Flight Safety Manager Handbook
- Flight Operations Briefing Notes

Issue 9

February 2010

- **A320 Family:** Evolution of Ground Spoiler Logic
- Incorrect Pitch Trim Setting at Take-Off
- Technical Flight Familiarization
- Oxygen Safety

Issue 6

July 2008

- **A320:** Runway Overrun
- FCTL Check after EFCS Reset on Ground
- **A320:** Possible Consequence of VMO/MMO Exceedance
- **A320:** Prevention of Tailstrikes
- Low Fuel Situation Awareness
- Rudder Pedal Jam
- Why do Certain AMM Tasks Require Equipment Resets?
- Slide/raft Improvement
- Cabin Attendant Falling through the Avionics Bay Access Panel in Cockpit

Issue 3

December 2006

- Dual Side Stick Inputs
- Trimmable Horizontal Stabilizer Damage
- Pitot Probes Obstruction on Ground
- **A340:** Thrust Reverser Unlocked
- Residual Cabin Pressure
- Cabin Operations Briefing Notes
- **Hypoxia:** An Invisible Enemy

