



This document is an English translation of the Final Report on the fatal accident involving the Falcon 50EX aircraft registered F-GLSA that occurred on October 20, 2014 at Vnukovo Airport, Moscow.

The translation was done as accurate as a translation may be to facilitate the understanding of the Final Report for non-Russian speaking people. The use of this translation for any purpose other than for the prevention of future accidents could lead to erroneous interpretations.

In case of any inconsistency or misunderstanding the original text in Russian shall be used as the work of reference.

INTERSTATE AVIATION COMMITTEE

AIR ACCIDENT INVESTIGATION COMMISSION

FINAL REPORT

Type of occurrence	Fatal accident
Type of aircraft	Airplane, Falcon 50EX
Registration	F-GLSA
Owner	Unijet Airline
Operator	Unijet Airline
Place of occurrence	Russia, Moscow (Vnukovo) Airdrome , coordinates: N 55°35'29,66", E 37°15'41,12"
Date and time	20.10.2014, 19:58 UTC (23:58 local time), night time

In accordance with ICAO Standards and Recommended Practices this Final Report has been published with the sole objective of aircraft accident prevention.

It is not the aim of this investigation to apportion blame or liability.

The criminal aspects of this accident are described within a separate criminal investigation.

SYNOPSIS	8
1. FACTUAL INFORMATION.....	9
1.1. HISTORY OF FLIGHT	9
1.2. INJURIES TO PERSONS	11
1.3. DAMAGE TO AIRCRAFT	11
1.4. OTHER DAMAGE	12
1.5. PERSONNEL INFORMATION.....	12
1.5.1. <i>Flight Crew Information</i>	12
1.5.2. <i>Cabin Crew Information</i>	15
1.5.3. <i>ATM Personnel</i>	16
1.5.4. <i>Airfield Service Personnel Information</i>	25
1.6. AIRCRAFT INFORMATION	27
1.6.1. <i>History of Maintenance</i>	28
1.6.2. <i>Amount and Quality of Fuel Taken before the Flight</i>	29
1.7. METEOROLOGICAL INFORMATION	30
1.8. AIDS TO NAVIGATION, LANDING AND ATC	36
1.8.1. <i>Radio Navigation Service</i>	36
1.8.1.1. <i>Navigation and Landing Aids</i>	36
1.8.2. <i>Airfield Surveillance Radar</i>	38
1.8.2.1. <i>Conflict Detection Settings of TRADIS as of 20.10.2014</i>	43
1.8.2.2. <i>Actual Conflict Detection Settings of TRADIS (A-SMGCS) at Controllers and Supervisor's Working Positions on 20.10.2014</i>	47
1.9. COMMUNICATION AND LIGHTING	58
1.9.1. <i>Basic Communication Aids</i>	58
1.9.2. <i>Standby Communication Aids</i>	59
1.9.3. <i>Communication Management During Airfield Operations</i>	59
1.9.4. <i>Runway Lights</i>	62
1.9.5. <i>Runway Lights on RWY 1 (06/24)</i>	62
1.9.6. <i>Runway Lights on RWY 2 (01/19)</i>	65
1.9.7. <i>Runway Lights Switched on RWY 1 on 20.10.2014</i>	67
1.9.8. <i>Runway Lights Switched on RWY 2 on 20.10.2014</i>	68
1.10. AIRDROME INFORMATION	69
1.11. FLIGHT RECORDERS	73
1.11.1. <i>Flight Data Recorder</i>	73
1.11.2. <i>Cockpit Voice Recorder</i>	74
1.11.3. <i>CVR and FDR Data Synchronization</i>	74
1.11.4. <i>Flight Path Calculation</i>	75
1.12. WRECKAGE INFORMATION.....	75
1.12.1. <i>Aircraft Condition</i>	77
1.12.2. <i>Damage to Snowplow</i>	93
1.13. MEDICAL AND PATHOLOGICAL INFORMATION	94
1.14. SURVIVAL ASPECTS	95
1.15. SEARCH AND RESCUE, FIRE FIGHTING OPERATIONS	95
1.16. TESTS AND RESEARCH	97
1.16.1. <i>Fuel and Oil Examination</i>	97
1.16.2. <i>Snowplow Lights Examination</i>	97
1.16.3. <i>Examination Conducted in France</i>	99
1.16.4. <i>Examination Conducted in the Netherlands</i>	102
1.16.5. <i>ELT Examination</i>	102
1.17. ORGANIZATIONAL AND MANAGEMENT INFORMATION	103
1.18. ADDITIONAL INFORMATION	103
1.18.1. <i>Aerodrome Air Traffic Control</i>	103
1.18.2. <i>On-the-Job Training Arrangements</i>	111
1.18.3. <i>Airfield Surveillance Radar System Training for Controllers</i>	115
1.18.4. <i>Aerodrome Service Vehicles</i>	115
1.18.5. <i>Safety Management System (SMS) at Vnukovo AP</i>	120
1.18.6. <i>SMS in the Air Traffic and Radio Navigation Service of Vnukovo ATC Center</i>	125
2. ANALYSIS.....	128
2.1. SEQUENCE OF EVENTS AND FLIGHT DESCRIPTION	128
2.2. ANALYSIS OF AIRCREW, ATM AND AIRDROME SERVICE STAFF ACTIONS.....	179
2.2.1. <i>Analysis of Airdrome Service Staff Actions</i>	179

2.2.2.	<i>Analysis of ATC Controllers and Shift Supervisor actions and Operation of Airfield Surveillance and Control Subsystem A3000</i>	195
2.2.3.	<i>Flight Crew Status and Actions Analysis</i>	215
3.	CONCLUSION	222
4.	SHORTCOMINGS	225
5.	SAFETY RECOMMENDATIONS	229

COURTESY ENGLISH TRANSLATION

Abbreviations

ACAS	Airborne Collision Avoidance System
AD	Airworthiness Directive
A/D	Aerodrome
ADF	Automatic Direction Finder
ADSB	Automatic Dependent Surveillance Broadcast
AFM	Airplane Flight Manual
AIP	Aeronautical Information Publication of the Russian Federation and the Commonwealth of Independent States
AMICPTC	Automated Meteorological Information Collection, Processing and Transmitting Complex
AOA	Angle of Attack
AON-92	Civil Aerodrome Operation Norms in USSR. Third edition, 1992
AP	Airport
AP-139	Aviation Rules. Part 139 "Certification of Airdromes" made effective by Order № 308 by the Ministry of Transport as of 06.11.2014 (terminated by Order № 316 by the Ministry of Transport as of 26.10.2015)
APU	Auxiliary Power Unit
ARP	Airdrome Reference Point
A-SMGCS	Advanced Surface Movement, Guidance and Control Systems
ATC	Air Traffic Control
ATM	Air Traffic Management
BEA	Aircraft Accident Investigation Bureau of France (Bureau d'Enquêtes et d'Analyse pour la sécurité de l'aviation civile)
CAA	Civil Aviation Authority
CAOM RF-94	Civil Airport Operations Manual of Russian Federation, approved by Order № ДБ-98 of Department of Air Transport as of 19.09.1994
CAT	Category
CG	Center of gravity
CVR	Cockpit Voice Recorder
DGAC	Directorate General for Civil Aviation (France)
Delivery	Flight support unit having a separate radio contact frequency to provide information on departure routes; line information on limitations, prohibitions for air passages, tracks, destination and alternate airdromes; information on modes; information on weather changes at departure

(destination, alternate, en-route) airdrome that are not consistent with rules of go decision or affect en-route traffic rules; warnings on adverse weather conditions; individual secondary surveillance radar code (if required) and other information related to flight safety.

DME	Distance Measuring Equipment
DVOR	Doppler VHF Omni Directional Radio Range
DSB	Dutch Safety Board
EASA	European Aviation Safety Agency
ELT	Emergency Locator Transmitter
FATA	Federal Air Transport Agency
FAR	Federal Aviation Rules
FAR-116	FAR "Certification of Objects of the Unified Air Traffic Management System" approved by Rosaeronavigatsiya's Order № 116 as of 26.11.2007.
FAR-128	FAR "Preparation and Conduct of Flights in Civil Aviation of the Russian Federation" approved by Order № 128 of Russian Ministry of Transport as of 31.07.2009.
FAR-216	FAR "Requirements to Air Traffic Control Officers and Parachuting Instructors" approved by Order № 216 of Russian Ministry of Transport as of 26.11.2009.
FAR-262	FAR "Requirements to Airdromes Used for Takeoff, Landing, Taxiing and Parking of Civil Aircraft" approved by Order № 262 of Russian Ministry of Transport as of 25.08.2015.
FAR-293	FAR "Air Traffic Management in the Russian Federation" approved by Order № 293 of Russian Ministry of Transport as of 25.11.2011.
FAR-362	FAR "Procedure for the Conduct of Radio Communication in the Air Space of the Russian Federation" approved by Order № 362 of Russian Ministry of Transport as of 26.09.2012.
FDR	Flight Data Recorder
FIA	Flight Information Area
FO	First Officer
GCAS	Ground Collision Avoidance System
GPS	Global Positioning System
HIRL	High Intensity Runway Lights
HQB	Highest Qualification Board

IAC	Interstate Aviation Committee
ICAO	International Civil Aviation Organization
ILS	Instrument Landing System
JAA	Joint Aviation Authorities
kt	Knots
LH	Left-hand
MAMC	Main Aviation Meteorological Center
METAR	Actual airdrome weather report
MLAT	Multilateration
MMPI	Minnesota Multiphasic Personality Inventory
MRM	Maintenance and Repair Manual
MSN	Manufacturer Serial Number
NMSCA-95	Norms for Meteorological Service in Civil Aviation, issued in 1995.
NOTAM	Notice to airmen
OJT	On-the-job Training
PIC	Pilot-in-command
PF	Pilot Flying
PM	Pilot Monitoring
PRAPI-98	Rules for Investigation of Accidents and Incidents Involving Civil Aircraft in Russian Federation, approved by Governmental Resolution № 609 as of 18.06.1998
SMS	Safety Management System
SRS	Search and Rescue Service
RH	Right-hand
Rosaeronavigatsiya	Russian Air Navigation Agency
Rosaviatsiya	Russian CAA
RTF	Radiotelephony phraseology
RVR	Runway Visual Range
RWY	Runway
SARPs	Standards and Recommended Practices
SB	Service Bulletin
SIGMET	Significant Meteorological Information
SOP	Standard Operating Procedures
QFE	Atmospheric Pressure at Aerodrome Elevation
QNH	Barometric Pressure Adjusted to Sea Level

TAF	Terminal Aerodrome Forecast
TRADIS	Traffic Display (presents the traffic situation on the airport to the controller)
TWY	Taxiway
UTC	Universal Time Coordinated
WP	Working position

COURTESY ENGLISH TRANSLATION

Synopsis

On 20.10.2014, at 19:58 UTC¹ (23:58 local time), at night, during takeoff at Moscow (Vnukovo) A/D a Falcon 50EX F-GLSA aircraft operated by Unijet crashed while conducting charter flight LEA074P from Moscow (Vnukovo) to Paris (Le Bourget).

The Air Accident Investigation Commission of the Interstate Aviation Committee was notified on the accident at 22:17 on October 20, 2014.

The investigation team was appointed by Order of the Air Accident Investigation Commission Chairman, Vice-Chairman of Interstate Aviation Committee № 40/699-p of 21.10.2014 and № 40/699-pa of 12.01.2015.

The investigation was participated by experts from Rosaviatsiya, Roshidromet, State Center of Flight Safety, as well as from airlines operating Falcon aircraft. The accident investigation authority (BEA) of the State of Design and Manufacture (France) was notified on the accident. An Accredited Representative of France and his Advisors (representatives of the BEA, aircraft designer and manufacturer and the Operator) participated in the accident investigation.

The notification on the accident was also sent to the accident investigation authority of the Netherlands (DSB). The investigation was participated by an Accredited Representative of the Netherlands and experts from the manufacturer of the airfield surveillance and control subsystem A-3000.

Investigation was started on 21.10.2014.

Investigation was completed on 24.10.2016.

Preliminary judicial inquiry was conducted by the Main Inquiry Office of the Inquiry Board of the Russian Federation.

¹ Hereinafter UTC time is provided.

1. FACTUAL INFORMATION

1.1. History of Flight

The aircrew prepared for the flight Paris - Moscow - Paris on October 19, 2014 at the flight operations department of Unijet. The Flight Ops Director of Unijet briefed the PIC. Particular attention was paid to the peculiarities of Vnukovo AP, as the crew had no experience of flying to the mentioned airdrome.

The flight from Paris to Moscow was uneventful. After landing at Vnukovo AP, at 21:30 on October 19, 2014 the crew of Falcon 50EX F-GLSA including the PIC, FO, and a flight attendant were brought to the Novotel City Hotel (2, Presnenskaya Quay, Moscow) for their after-flight rest.

At 13:52 on October 20, 2014 the crew arrived at Vnukovo AP. The crew transportation was arranged by VIPPORT LTD.

At 13:57 a VIPPORT LTD representative provided the crew with the flight plan, weather forecast, NOTAM and briefing information.

Note: *Extract from the VIPPORT LTD representative explanations as of October 28, 2014:*

"At about 17:55 (Moscow time) I printed out the preflight documents to be provided to the crew before the flight:

the flight plan – printed out from the AFTN;

Weather information – printed out from the MAMC Aviation Meteorological Database Service-Terminal;

NOTAMs – printed out from an Internet service at <https://www.notams.faa.gov>;

Briefing information - printed out from the attached file to an email sent from ops@unijet.fr (Unijet) to ops@vipport.ru (VIPPORT LTD Operational Control Center). In the mentioned email the Operator asked to provide the briefing information to the crew before the flight. The email was delivered at 12:27 Moscow time on October 20. At approximately 17:57 Moscow time I met the crew at the crew check-in desk. I handed the documents to them personally (the flight plan, the weather information, NOTAMs and the briefing information).

The crew requested refueling from the VIPPORT LTD representative.

At approximately 14:25 the crew was brought on board the Falcon 50EX F-GLSA.

Note: *Extract from the VIPPORT LTD representative explanations as of October 28, 2014:*

The crew asked to arrange refueling and call the catering. I asked if they needed deicing but the crew replied that they were not sure yet as they had to see the aircraft first.

At about 18:25 Moscow time the crew decided to get on board. I arranged transport for them to get to the aircraft stand.

At 15:15 the VIPPORT LTD representative approached the aircraft and clarified if the crew was ready for the flight. The crew confirmed they were ready but asked to order extra bread.

At 15:30 the VIPPORT LTD representative reported the crew of Falcon 50EX F-GLSA was ready for dispatch.

Note: *Extract from the VIPPORT LTD representative explanations as of October 28, 2014:*

"At about 19:15 Moscow time I came to the aircraft to check if the crew was ready for the flight. They said they just needed to order extra bread which was forwarded to the catering service and completed by about 19:20 Moscow time. Then I asked if the crew was ready for the flight, which was confirmed. At 19:30 Moscow time I reported the aircraft was ready for dispatch. Then I asked the crew to contact us if needed at VIPPORT frequency 122.875 MHz. While I was present at the Ground Handling Office the crew contacted us once to get to know if a passenger has arrived at the terminal. They did not ask for any other service."

In accordance with the flight plan the crew planned to make an unscheduled commercial flight LEA074P to transport one passenger from Moscow (Vnukovo, UUWW) to Paris (Le Bourget, LFPB). The takeoff was planned for 18:00.

The crew requested engine startup 1 hour and 49 minutes later than planned though VIPPORT LTD had not informed the ATM on the delay of the unscheduled flight LEA074P.

At 19:45 one passenger was brought on board the aircraft accompanied by a representative of Business Aviation Center LTD.

Note: *Extract from the Business Aviation Center LTD representative explanations as of October 21, 2014:*

"At 23:45 Moscow time I was supporting dispatch of aircraft F-GLSA, Flight LEA074P, departing to Paris. One passenger was checked in for the flight (passenger name). I accompanied him on Bus 93 and we went to the

aircraft stand – Stand 24. The passenger embarked."

At 19:58, during takeoff from RWY 1, Vnukovo AP, the aircraft collided with a snowplow located at the crossing of RWY 1 and RWY 2 and collapsed. The fire on the destroyed aircraft was extinguished by the airport firefighting service. The crew and passenger were killed in the accident. The snowplow driver was not injured. The snowplow was damaged.

1.2. Injuries to Persons

Injuries to Persons	Crew	Passengers	Others
Fatal	3	1	0
Serious	0	0	0
Minor/None	0/0	0/0	0/1 ²

1.3. Damage to Aircraft

The aircraft collapsed, the ground fire emerging after the collapse was extinguished by the airport firefighting service.

The collapsed aircraft is shown in Figure 1.



Figure 1. Falcon 50EX F-GLSA airplane at the accident site

² The driver of the snowplow that the airplane collided with.

1.4. Other Damage

The damage to snowplow is described in Section 1.12.2. No other objects were damaged.

1.5. Personnel Information³

1.5.1. Flight Crew Information

Captain

Sex	Male
Date of birth	14.02.1969
Pilot's license	Nº FRA.FCL.AA00045414
Date of issue, authority	04.12.2013, DGAC (France)
Date of expiry	Unlimited
License category	ATPL (A)
First issue of ATPL (A)	30.09.2009
Valid type rating	Falcon 50, Cessna C-525
Falcon 50 IFR rating	26.03.2014, valid till 26.03.2015
C-525MP IFR rating	25.10.2013, valid till 31.10.2014
C-525MPO IFR rating	09.10.2014, valid till 31.10.2015
English for radio exchange	ICAO level 5, valid till 30.09.2016
Total flight hours	6624.5 hours
including	
multi-engine aircraft	5974.5 hours
IFR	1954.5 hours
as FO	2920 hours
as Captain	3304.5 hours
Total, jet airplanes	3347.5 hours
Falcon 50	1266 hours
Over last 12 months	334.58 hours
Over last 3 days	11.23 hours
On accident day	28 seconds
Simulator training	13.05.2014
Medical examination	25.09.2014
Medical certificate	Class 1

³ Crew information was provided by the Accredited Representative for France.

Medical certificate validity	expiring on 30.09.2015
Preflight rest	At least 8 hours in a hotel
Preflight medical check	Not prescribed
Total duty time on the accident day	6 hours 06 minutes
Previous accidents or incidents	None

According to the available documents, the Captain served at the French Navy from 1993 till September 2010 as a lieutenant commander and had the following flying experience in the Navy:

- 1996 to 1999 - Captain on Nord 262 and Embraer 121 type aircraft;
- 1999 to 2000 - Captain and instructor on Falcon 10 type aircraft;
- 2000 to 2004 - Captain on Falcon 50M type aircraft;

Note: *The Captain underwent initial Falcon 50 type rating training from 29.01.2001 to 16.02.2001 at Falcon Training Center of Dassault Falcon and Flight Safety International.*

He underwent recurrent Falcon 50 training from 19.11.2001 to 20.11.2001 at Falcon Training Center of Dassault Falcon and Flight Safety International.

The Captain underwent Falcon 50 Basic Pilot Training in February 2002 at Falcon Training Center s.n.c.

- 2004 to 2006 - Captain on Falcon 200 type aircraft;

Note: *The PIC underwent Falcon 200 type rating training in June 2004 at Falcon Training Center s.n.c.*

- 2006 to 2009 - Captain and instructor on Nord 262 and Embraer 121;
- 2009 to 2010 - Captain and instructor on Falcon 10 type aircraft;

The Captain had flown in Europe, Middle East, South-Pacific, the USA, the Caribbean and French Guinea.

Note: *Nord 262 airplane is a tactical military transport middle-range airplane designed by a French company, Nord-Aviation.*

Embraer 121 is a transport general aviation aircraft meant for improving flying skills, was used as a training and liaison airplane for the French Navy and Air Forces. The airplane delivery was terminated in 1983.

Falcon 50 is one of the administrative jet family of Dassault Mystere-Falcon. The Mystere-Falcon 10 model could be equipped for aerial

photography, sanitary and liaison flights, etc. Some of such airplanes are used in the French Navy as Falcon 10MER.

Falcon 50 is a long range administrative three-engine jet aircraft. Its manufacturing was terminated in 2008.

Falcon 200 is a middle class business jet, a modification of Falcon 20, manufactured in a limited batch. It features more powerful engines and additional fuel tanks in the aft part of the fuselage. The aircraft was used in the French Air Forces.

Since 2010 the Captain worked in Unijet as a PIC of Falcon 50 and PIC of Cessna C 525.

In October 2010 he underwent Citation Cit Jet type rating training (Cessna Citation Jet CJ2 model) at the Farnborough Training Center (UK) and was granted a Flight Safety International certificate on 27.10.2010.

In October 2013 the Captain underwent recurrent Citation Cit Jet type training (Cessna Citation Jet CJ2 model) at the Farnborough Training Center (UK) and was granted a Flight Safety International certificate on 25.10.2013.

In November 2013 the Captain underwent DA-50 training (Falcon 50 type), an initial pilot training course in accordance with the JAA regulations at the Paris Training Center and was granted a Falcon Training s.n.c. certificate.

Within 2014 the Captain made regular flights on Falcon 50EX.

FO

Sex	Male
Date of birth	11.07.1986
Pilot's license	Nº FRA.FCL.CA00280871
Date of issue, authority	04.12.2013, DGAC (France)
Date of expiry	Unlimited
License category	CPL (A)
First issue of CPL (A)	24.09.2009
Valid type rating	Falcon 50, Cessna C-525
Falcon 50 IFR rating	03.08.2014, valid till 03.08.2015
C-525 IFR rating	30.08.2013, valid till 31.08.2014
C-525MPO IFR rating	03.07.2014, valid till 31.08.2015
English for radio exchange	ICAO level 4, valid till 31.03.2015
Total flight hours	1478 hours

including	
multi-engine aircraft	1372.83 hours
IFR	1433 hours
as FO	1363.42 hours
as PIC	114.58 hours
Total, jet airplanes	1372.84 hours
Falcon 50	246 hours
Cessna C-525	1129.92 hours
Over last 12 months	361.75 hours
Over last 3 days	11.23 hours
On accident day	28 seconds
Simulator training	21.11.2013
Medical examination	26.06.2014
Medical certificate	Class 1
Medical certificate validity	expiring on 30.06.2015
Preflight rest	At least 8 hours in a hotel
Preflight medical check	Not prescribed
Total duty time on the accident day	6 hours 06 minutes
Previous accidents or incidents	None

The FO was employed by Unijet as a FO since February 2011. Within 2014 he conducted regular flights on Falcon 50EX.

Within the last year the PIC and the FO were flying as fixed crew.

1.5.2. Cabin Crew Information

Flight Attendant⁴

Sex	Female
Date of birth	23.04.1975
Preflight rest	At least 8 hours in a hotel
Total duty time on the accident day	6 hours 06 minutes

⁴ As per the AFM the minimum crew composition of the Falcon 50EX can include two pilots only. The presence of a cabin attendant is not mandatory.

1.5.3. ATM Personnel

ATC Shift Supervisor

Position	ATC shift supervisor, order № 14/1-002871 of Moscow ATM Center Director, ATM State Corporation as of 15.09.2014.
Sex	Male
Year of birth	1978
Education	Graduated from Saint-Petersburg Academy of Civil Aviation in 1999, diploma ABC № 0838878.
Recurrent training	24.06.2013, Corporate Personnel Training Center - Air Navigation Institute Certificate № 003250.
Class	Air traffic controller, Class 1, HQB of Rosaeronavigatsiya's meeting minutes № 19 as of 09.12.2005.
Air Traffic Controller's License	СД № 015605, issued by Russian Federal Aviation Service as of 28.06.1999. Expiring on 10.09.2016.
Annual medical examination	Medical Flight Expert Board of Vnukovo AP medical unit, 12.12.2013 Medical Certificate № 130606. Fit to work as air traffic controller. Valid till 12.12.2015.
Authorizations ⁵ :	Departure controller, order № 116/л of Moscow ATM Center Director, ATM State Corporation as of 14.02.2000; Arrival controller, order № 571/л of Moscow ATM Center Director, ATM State Corporation as of 16.07.2001; Approach controller, order № 62 of Moscow ATM Center Director, ATM State Corporation as of 29.03.2005;

⁵ Data extracted from the air traffic controller's license.

	<ul style="list-style-type: none"> - shift supervisor, order № 175 of Moscow ATM Center Director, ATM State Corporation as of 09.06.2006; - shift supervisor at helipads 1 and 7 and helipads using Mobile Tower Control of Vnukovo ATM Center, order № 720 of Moscow ATM Center Director, ATM State Corporation as of 11.10.2007; - ATC instructor, order № 898 of Moscow ATM Center Director, ATM State Corporation as of 03.12.2009; - Approach Controller (Sector 2, joint), order № 424 of Moscow ATM Center Director, ATM State Corporation as of 29.05.2012;
Date of last skills check	11.02.2014 at airdrome shift supervisor working station, checked by the Head of Vnukovo ATC Center, Moscow ATM Center Director, ATM State Corporation. Conclusion - fit for job.
Preflight rest	At least 8 hours at home
Total duty time on the accident day before the accident	3 hours 27 minutes ⁶
Medical check before duty	Conducted by a medical assistant at Moscow ATM Center medical station of Vnukovo AP medical unit at 16:31.
Previous accidents or incidents	None
Location during accident	Airdrome shift supervisor's working station

⁶ The duty time of ATM officers was calculated from the time they passed the medical examination.

Departure Controller (out of staff instructor controller, further referred to as instructor controller)

Position	Departure Controller, order № 06/П-0477 by head of Moscow ATM Center, FATA, Russian Ministry of Transport as of 01.06.2006. In 2011 assigned the position of Approach Controller by Order № 11/П-0022/9 of Moscow ATM Center Director, ATM State Corporation as of 17.08.2011.
Sex	Male
Year of birth	1978
Education	Graduated from Riga Air Navigation Institute in 1998, diploma № 895154.
Recurrent training	Recurrent training on 20.10-16.11.2011 at Corporate Personnel Training Center – Air Navigation Institute as per the Program "Air Traffic Control Using the English Language..." Certificate № MCK № 2272.13807. 15.10.2014, Corporate Personnel Training Center - Air Navigation Institute Certificate № 004222.
Class	Class 1 Air Traffic Controller, HQB of Russian CAA meeting minutes № 19 as of 26.12.2013.
Air Traffic Controller's License	СД № 002953, issued by the Russian CAA. 29.12.2001. Expiring on 19.11.2015.
Annual medical examination	Medical Flight Expert Board of Vnukovo AP medical unit, 11.11.2013. Medical Certificate PA № 111626. Fit to work as air traffic controller. Valid till 11.11.2015.

Authorizations ⁷ :	<ul style="list-style-type: none"> - Ground Controller, order № 286/П as of 26.12.2002, stamp of Moscow ATM Center, State ATM Corporation, 30.12.2002; - Tower Controller, order № 27 as of 26.12.2003, stamp of Moscow ATM Center, State ATM Corporation, 26.12. (year not mentioned); - Approach Controller, order № 45 as of 14.04.2005, stamp of Moscow ATM Center, State ATM Corporation, 14.04.2005;- Tower Controller at Vnukovo AP, stamp of Rosaviatsiya HQB, 18.08.2006. - Approach Controller, Vnukovo Tower, stamp of Moscow ATM Center, State ATM Corporation, 11.11.2008; - out of staff ATC instructor, order № 286/П as of 26.12.2002, stamp of Moscow ATM Center, State ATM Corporation, 30.12.2002.
Date of last skills check	23.11.2013 at Tower Controller working station, checked by senior shift controller, Vnukovo ATC Center. Conclusion - can be ranked Class 1.
Date of latest simulator check	20.10.2014 checked by senior controller instructor of Vnukovo ATC Center Simulator Center. Conclusion - fit for job. The record was made after the accident.
Date of last check as instructor	11.04.2014, not recorded in the personal log book
Date of last skills check	26.12.2013, as Class 1 was granted, Rosaviatsiya HQB meeting minutes № 10 as of 26.12.2013.
Rest before duty	At least 8 hours at home
Total duty time on the accident day before the accident	3 hours 35 minutes

⁷ Data extracted from the air traffic controller's license

Medical check before duty	Conducted by a medical assistant at Moscow ATM Center medical station of Vnukovo AP medical unit at 16:23.
Previous accidents or incidents	None
Location during the accident	Departure Controller's working station

Assignment as an out of staff instructor

First Deputy Director of State ATM Corporation in his letter of 17.08.2011 № 4.1.1-08801 informed directors of subsidiary centers of State ATM Corporation on the possibility to hire out of staff air traffic controller instructors.

Note: *Out of staff ATC instructor - according to the job description - is an air traffic controller who is authorized, by an order of the employer, to train an applicant for being authorized to work at an ATC working station.*

By order № 601⁸ of Deputy Director for ATM of Moscow ATM Center, State ATM Corporation as of 01.09.2011 with reference to letter № 4.1.1-08801 as of 17.08.2011, an air traffic controller neither having a Class 1 qualification nor trained as an ATC instructor, thus demonstrating no prerequisites to be authorized as an ATC instructor, was actually authorized to work as an out of staff instructor.

There was no documented decision of an aviation authority though required by Order № 93 of the Russian Ministry of Transport.

Note: *1. FAR-216*

Para 37. To get an authorization as an air traffic controller instructor (including air traffic control simulator instructor) an Applicant shall:

1) have

- a valid license and a Class 1 Air Traffic Controller qualification;

- an air traffic controller instructor training certificate;

2. Supplement to Order № 93 of the Russian Ministry of Transport:

⁸ Order № 601 of Deputy Director for ATM of Moscow ATM Center, State ATM Corporation as of 01.09.2011 was issued with violations of requirements stated in Letter № 4.1.1-08801 of First Deputy Director of State ATM Corporation as of 17.08.2011: the order did not determine staff instructor controllers to supervise the probation.

"Para 32. A basis for getting authorization as an ATC shift supervisor, senior air traffic controller or air traffic controller instructor is the following:

- education and working experience in accordance with Federal Aviation Rules "Requirements to air traffic controllers and parachuting instructors", approved by Order № 216 of Russian Ministry of Transport as of 26.11.2009 (registered by Ministry of Justice on 15.01.2010, registry № 15996).*
- a nomination, signed by the head of an ATM center, confirmed by a stamp;*
- a training certificate for the applicable authorization;*
- a positive conclusion of the psychological and professional evaluation;*
- successful completion of on-the-job training;*
- positive results of the practical skills check for the applicable position;*
- results of knowledge check for the applicable position;*
- decision of the applicable civil aviation authority.*

Para 33. Authorization to work as ATC shift supervisor, senior air traffic controller or air traffic controller instructor is documented by an order of the employer. Pertinent decision of the civil aviation authority serves as a basis for the mentioned order (revision introduced by Order № 144 of Russian Ministry of Transport as of 14.05.2012)."

A request made by the investigation team to Russian Ministry of Transport was responded as follows: "After receiving a state authorization to work as an ATC instructor an expert can be assigned to a position of instructor controller by the Employer or conduct personnel training as a freelance instructor controller having pertinent skills, abilities and knowledge in the subject area, including both theoretical and practical aspects of induction training. ...the regulations establish unified pre-requisites to be authorized for performing functions of an ATC instructor, but not requirements for the pertinent position".

Thus, the investigation team assumes that regardless of the position in the company (staff or freelance) an ATC instructor shall undergo applicable training and demonstrate a certain set of skills, abilities and knowledge. The level of training acquired by the freelance instructor did not comply with the regulations.

It shall be noted that Para 48 of the Supplement to Order № 93 of Russian Ministry of Transport, requires that "the results of operational check and use of recording devices shall be recorded in a controller's personal log book". The investigation team was provided with instructor evaluation sheet № 2 approved by the Head of Vnukovo ATC Center on 22.04.2014, wherein the ATC instructor was checked on 11.04.2014 and was evaluated as fit for job. Meanwhile there was no record in the controller's personal log on the check.

Note: As explained by the management of Vnukovo ATC Center this record was not made as the position of ATC instructor was out of staff, while the requirements of Order № 93 are only applicable to staff instructors.

However, the Russian Ministry of Transport responded to the request from the investigation team as follows: "With regard to Para 48 of the Rules⁹, please note that in accordance with the aviation regulations working instructions are worked out in order to be applied by ATM officers at specific ATM offices (sectors) and are subject to monitoring, including recorder readout, which corresponds with Para 47 of the abovementioned Rules".

The air traffic controller's log book contains a record of training conducted on 20.10.2014 from 07:00 to 09:00 on the Synthesis SC-V simulator at the Tower Controller's working station. Training content - seasonal training, autumn 2014/winter 2015. Conclusion: "Training conducted. Fit for job" - "Senior ATC instructor, simulator center".

There is a similar record (№ 385) on simulator training conducted on 20.10.2014 (on the day of the accident) from 07:00 to 09:00 in the Log of Simulator Training on the Synthesis SC-V ATC Simulator of Vnukovo ATC Center, Moscow ATC Center subsidiary, State ATM Corporation. However, on 08.12.2014 while being interrogated the ATC instructor responded the question concerning his simulator training on 20.10.2014 in the following way: "On 20.10.2014, before starting my duty, I did not undergo any simulator training as I did not have to." Being interrogated on December 18, 2015 the ATC instructor had the following statement to add: "...before I went to work, namely until 18 h 00 min Moscow time I was at home".

Thus it seems obvious that the records in the air traffic controller's log book and the Log of Simulator Training concerning the simulator training on 20.10.2014 were made after the accident.

⁹ The term Rules in this response stands for Order № 93 of the Ministry of Transport

Trainee Controller

Position	Trainee Controller, order № 14/JI-002406 of Moscow ATM Center Director, ATM State Corporation as of 05.08.2014;
Sex	Female
Year of birth	1991
Education	Graduated from Ulyanovsk Civil Aviation College (Institute), diploma № 1073050037736
Recurrent training	From June 6 to 25, 2014, recurrent training at Corporate Personnel Training Center - Air Navigation Institute: Aviation English (RTF for ATC personnel authorize to provide ATC in English). Certificate № 002558, issued on 16.06.2014.
Class	Not assigned
License category	Not issued
Annual medical examination	Medical Flight Expert Board of Ulyanovsk Civil Aviation College medical unit
29.01.2014. Medical Certificate № 080083. Fit to work as air traffic controller. Valid till 29.01.2016	
Authorization for probation:	Order № 742 of Moscow ATM Center Director, ATM State Corporation as of 06.08.2014;
Date of last knowledge check	25.08.2014, checked by out of staff ATC instructor of Vnukovo ATC Center Conclusion - can be admitted to practical training
Rest before duty	At least 8 hours at home
Total duty time on the accident day before the accident	3 hours 19 minutes
Medical check before duty	Conducted by a medical assistant at Moscow ATM Center medical station of Vnukovo AP medical unit at 16:39.
Previous accidents or incidents	None
Location during the accident	At the joint Departure Control working station under supervision of ATC instructor

Ground Controller (controller 4)

Position	Ground controller, Order № 122 of Moscow ATM Center Director, ATM State Corporation as of 22.03.1993;
Sex	Female
Year of birth	1958
Education	Graduated from Training Center 21 of Moscow Technical University of Civil Aviation in 1978. Diploma (duplicate) № 1774.
Recurrent training	7.02.2014, Corporate Personnel Training Center - Air Navigation Institute Certificate № 002645
Class	Class 1 Air Traffic Controller, HQB of Moscow ATM Center meeting minutes № 10 as of 14.06.2002.
Air Traffic Controller's license	СД № 018193, issued by Russian Federal Aviation Service as of 14.04.1998. Expiring on 16.03.2017
Regular medical examination	24.10.2012 at polyclinics of Vnukovo AP medical unit. No contra-indications detected ¹⁰ . Next regular examination planned on 24.10.2014.
Authorizations ¹¹	Ground Controller, order № 127/Л, stamp of AOOT Vnukovo AP, 22.03.1995.
Date of last skills check	21.02.2014 at Ground Controller working station, checked by senior ground controller, Vnukovo ATC Center. Conclusion - fit for job.
Rest before duty	At least 8 hours at home
Total duty time on the accident day before the accident	2 hours 53 minutes

¹⁰ The record in the ATC personal log book made by the Head of Vnukovo ATC Center is not consistent with the conclusion of the polyclinics of Vnukovo AP medical unit. Ground ATC officers do not undergo annual medical expert board examination, but do undergo regular medical examinations in accordance with Order № 302n of Ministry of Health.

¹¹ Data extracted from the air traffic controller's license

Medical check before duty	Conducted by a medical assistant at Moscow ATM Center medical station of Vnukovo AP medical unit at 17:05.
Previous accidents or incidents	None
Location during the accident	Ground Controller working station 1.

1.5.4. Airfield Service Personnel Information

Airfield Service Shift 3, operating on 20.10.2014

From 16:00 on 20.10.2014 to 04:10 on 21.10.2014 Shift 3 of airfield service was operating consisting of 53 persons.

Leading Engineer - Airfield Service Shift Supervisor

Male, born in 1963. Higher education, diploma № MB 538608 issued by Moscow Automobile and Road Institute on 24.06.1986. Total working experience in civil aviation 24 years, including 22 years in the current position. In 2014 he underwent recurrent special training for air transport managers and specialists involved in providing flight safety. Certificate № 1300-2014 issued by the Center of Conversion and Recurrent Training for Air Transport Personnel, Moscow State Technical University of Civil Aviation on 18.10.2014. Admitted to work in autumn 2014/winter 2015 by order № 3059/П of Vnukovo AP General Director as of 20.10.2014.

Driver of Foreign-made Airdrome Vehicle (driver of airfield service shift supervisor car)

Male, born in 1977. Class 3 driver. Education: secondary school graduate. Total working experience in civil aviation 6 years, including 2 years in the current position. Admitted to work in autumn 2014/winter 2015 by order № 3059/П of Vnukovo AP General Director as of 20.10.2014.

Driver of Foreign-made Aerodrome Vehicle (driver of snowplow 1)

Male, born in 1984. Class 1 driver. Education: secondary school graduate. Total working experience in civil aviation 4 years, including 8 months in the current position. Admitted to work in autumn 2014/winter 2015 by order № 3059/П of Vnukovo AP General Director as of 20.10.2014.

Driver of Foreign-made Aerodrome Vehicle (driver of snowplow 2)

Male, born in 1991. Class 2 driver. Education: secondary school graduate. Total working experience in civil aviation 3 years, including 1 year in the current position. Admitted to work in autumn 2014/winter 2015 by order № 3059/П of Vnukovo AP General Director as of 20.10.2014.

Driver of Foreign-made Aerodrome Two-Engine Vehicle (driver of snowplow 3, involved in the collision)

Male, born in 1954. Education: secondary school graduate. Driver's license (Categories B,C,D,E) № 50 OY 263227 issued by Chief Internal Affairs Office for Moscow Region on 09.12.2009. Class 1 driver. Total working experience in civil aviation: 10 years. Hired as airdrome vehicle driver by order № 857/П of Vnukovo AP General Director as of 08.10.2004. Admitted to unsupervised operations by order № 934/П of Vnukovo AP General Director as of 29.10.2004. Underwent training and admitted to unsupervised aerodrome operations on rotor snowplow SUPRA-5001 by order № 2302/П of Vnukovo AP General Director as of 01.11.2006. Admitted to work in autumn 2014/winter 2015 by order № 3059/П of Vnukovo AP General Director as of 20.10.2014.

Aerodrome Vehicle Mechanic

Male, born in 1942 Education: professional college. Total working experience in civil aviation 36 years, including 4 years in the current position. In 2011 he got certified in road transport safety. Admitted to work in autumn 2014/winter 2015 by order № 3059/П of Vnukovo AP General Director as of 20.10.2014. The mechanic was responsible for dispatching the aerodrome vehicles to line operations as operative, was authorized to sign waybills to the vehicle drivers of the applicable shift.

1.6. Aircraft Information¹²



Figure 2. Aircraft before the accident

Aircraft type	Falcon 50EX
Manufacturer, date of manufacture	Dassault Aviation (France), 29.11.2006
MSN	348
Registration	F-GLSA
Registration certificate	Nº B30465 of 18.01.2011
Certificate of Airworthiness	Nº 113361 issued by the DGAC on 18.01.2011 with no limitations
Service life between maintenance checks	On condition
Time since new	2197 hours, 1186 landings
Number of maintenance checks	1
Date of maintenance check	1C check conducted on 29.01.2013
Time since last maintenance check	352 hours, 227 landings

¹² Aircraft information was provided by the Accredited Representative for France.

Last base maintenance	1A and 1A+ checks conducted on 29.08.2014, total operating time 2166 hours 50 minutes, 1169 landings The check was conducted at TAG Aviation Geneva base, Le Bourget AP.
Last line maintenance	13.10.2014, operating time 2185 hours 10 minutes, 1184 landings

The aircraft had total operating time of 2197 hours and performed 1186 landings. The aircraft repair is compatible with a C check. Scheduled C checks are to be conducted on Falcon 50EX aircraft every 72 months.

1C check was conducted from 12.11.2012 to 29.01.2013 (date of release to service). At that time the aircraft operating time was 1845 hours 25 minutes, 959 cycles. Landing gear maintenance (every six years as per schedule) was conducted within the same time.

Engines

Engines TFE731-40-1C	Engine No.1 (LH) № P-115432/ 3060050-1	Engine No.2 (central) № P-115434/ 3060050-1	Engine No.3 (RH) № P-15433/ 3060050-1
Manufacturer, date of manufacture	Honeywell 05.08.2005	Honeywell 08.08.2005	Honeywell 05.08.2005
Total time since new	2197 h 30 min 1186 cycles	2197 h 30 min 1186 cycles	2197 h 30 min 1186 cycles
Last overhaul	13.08.2014	13.08.2014	13.08.2014
Time since last overhaul	35 h 20 min 23 cycles	35 h 20 min 23 cycles	35 h 20 min 23 cycles

Auxiliary Power Unit

GTCP36-100(A) MSN P-463/3800016-3 released by Honeywell on 24.09.1989. Time since new: 1186 hours. No overhauls.

The aircraft information has been provided by the Accredited Representative for France.

1.6.1. History of Maintenance

The aircraft was subject to both base and line maintenance.

The latest 1A and 1A+ checks were conducted on 29.08.2014, with total operating time 2166 hours 50 minutes and 1169 landings. The check was conducted at TAG Aviation Geneva base, Le Bourget AP. On 10.09.2014, with operating time 2169 hours 40 minutes, 1184 landings, a basic inspection was performed. According to the electronic database, the person supervising the maintenance tasks was a specialist holding license EASA Part 66 66A/B1/C/FR-006318.

The electronic database also contained information on A/A+ checks, 9 unscheduled tasks as per the Maintenance Program and 1 service bulletin (checks were accompanied with tasks to maintain the certified status and continuing airworthiness). During the checks 5 deviations were troubleshoot and rectified. None of the tasks was cancelled or postponed.

The mentioned maintenance was conducted by licensed engineers (Part 66 B1, Part 66 A and Part 66 B1 licenses) and exclusively by personnel certified for Falcon 50EX.

The time since last 1A/1A+ check was 30 hours and 40 minutes, 17 cycles.

Time since last line maintenance made on 13.10.2014 was 7 days, 12 hours and 20 minutes with operating time 2185 hours, 10 minutes, 1184 cycles.

Within the time of aircraft operation the following defects were found:

In June 2014 the pilot seat back actuator was replaced due to the recorded excess of the seat back deviation limitation.

In June 2014 there was a failure of the parking brake accumulator.

On 25.09.2014 the pilots reported that during braking the autobrake system green light did not go on. After the event an operational test of the autobrake was conducted in accordance with MRM 32-41-00-710-801, result satisfactory. The autobrake system was tested at a speed of up to 50 kt. In order to prevent recurrent fault the brake pressure relays were replaced. After that there were no reports of this fault.

EASA AD 2014-0024 related to the mandatory SB F50-530 "Installation of a protective plate on the electrical wiring under the glareshield" was planned to be accomplished on 04.01.2015 within the 4A check due to the deadline of April 2020 being set to EASA.

EASA AD 2013-0255, Paragraph 3 "Main Landing Gear Brake Hoses - Modification". The first part of this AD with a deadline of August 2014 was accomplished in February 2014. Paragraph 3 with a deadline of April 2026 or 5901 flight cycles was planned to be accomplished during the following C check.

EASA AD 2008-0021 "Wings primary structure – Inspection" was planned to be accomplished after 14200 cycles.

There had been no other applicable AD or mandatory SB unaccomplished.

1.6.2. Amount and Quality of Fuel Taken before the Flight

The Falcon 50EX F-GLSA aircraft was refueled with 3015 liters (2427 kg) of TS-1 fuel (0.14% of anti-icing fluid) from 14:30 to 14:45 on 20.10.2014 based on request № 0070212. The aircraft was refueled by the TS-20 fuel-servicing truck, garage number 65, based on the fuel bill № 907 of 20.10.2014. As the fuel-servicing truck was prepared for the refueling the fuel was checked for mechanical additives or water, which is confirmed by the signatures of accountable

persons in the fuel bill. The quality of the fuel was confirmed by Quality Passport № 8379 of 18.10.2014. Crews of other aircraft refueled from the same truck did not have any complaints about the fuel quality.

The investigation team took fuel samplings from the fuel truck as well as the fuel filters of the Falcon 50EX three engines to be thoroughly analyzed at the fuel laboratory of State Science and Research Institute of Civil Aviation. The analysis of the TS-1 fuel samplings taken from the fuel truck as well as the fuel filters of the Falcon 50EX three engines, the kerosene complied with the State quality standards.

1.7. Meteorological Information

The meteorological support of the Falcon 50EX F-GLSA was provided by the shift-on-duty of the Federal State Budget Enterprise "Roshydromet MAMC" (License № P/2012/2035/100/JI as of 26.03.2012).

The weather observations at Vnukovo A/D (Moscow) was accomplished by a meteorologist of the Roshydromet MAMC from the basic observation point located in the Tower with use of the aerodrome weather information and measuring system AMIS-RA, its sensors located near the beacons, landing areas and central points of RWY 1 and RWY 2. The weather measurement sensors as part of the AMIS-RF system at Vnukovo A/D are installed in compliance with AON-92. All measuring equipment was checked by Federal State Unitary Enterprise "Mendeleyev National Science and Research Institute of Meteorology" on 31.05.2014. Routine observations are accomplished at 00 minutes and 30 minutes of every hour. Reports based on the routine observations are formed automatically by the AMIS-RF system and issued as routine local weather reports and METAR reports. Specific observations are conducted additional to the routine observations in case the weather conditions deteriorate or improve as per criteria approved by the Vnukovo ATC Center. Based on the instrumental weather observations, local weather reports are formed and issued on the minutely basis via the Tower Automation Complex "Synthesis-A2(VN)" to working stations of air traffic controllers and ATIS operator of Vnukovo ATC Center, Moscow ATM Center, State ATM Corporation in accordance with the Instruction on Weather Information Provision at Moscow A/D (Vnukovo).

The weather conditions at Moscow A/D (Vnukovo) on 20.10.2014 were determined by the influence of the warm sector of the cyclone shifting from Scandinavia to the south-east. The system of the moderate latitude atmospheric front was related to the cyclone. The pressure in the cyclone center was 993.7 hPa. The cyclone was a low baric formation observed as a looped horizontal terrain contour but at 850 hPa. As per 700 hPa data for 12:00, a north-westerly wind was observed over Moscow Region that was conducive to the south-east shift of the cyclone with

a speed of 10-15 km/h. The warm front was located in the east of Moscow in parallel streams hardly moving. According to the vertical sounding data at 00:00 and 12:00 from Dolgoprudny aerological station (Moscow), temperature inversion could be observed in the surface layer. The high moisture content in the warm sector of the cyclone within the entire lower troposphere and the presence of temperature inversion were conducive to the formation of low clouds, fog and drizzle at Moscow A/Ds.

On 20.10.2014 the meteorologist-on-duty of the Roshydromet MAMC provided the shift of Vnukovo ATC Center acquiring duty with remote oral weather briefing reporting the retaining fog, visibility 300-700 m and vertical visibility 30-70 m at Vnukovo A/D within the duty period up to 04:00 on 21.10.2014.

According to the daily departure schedule for 20.10.2014 Flight LEA074P from Moscow (Vnukovo) to Paris (Le Bourget) was planned for 18:00. The crew of Falcon 50EX F-GLSA did not request weather documentation from the Roshydromet MAMC before their flight.

Note: *As per NMSCA-95 and ICAO Annex 3 "Meteorological Service for International Air Navigation", the following weather information shall be provided to flight crews conducting international flights as part of flight documentation: AF/TAF AMD, METAR/SPECI reports for the airdromes of departure and intended landing, and for takeoff, en-route and destination alternate aerodromes, SIGMET information, volcanic ash and tropical cyclone advisory information relevant to the whole route, significant weather charts, upper wind and upper air temperature charts.*

At 13:59 on 20.10.2014 there was a recorded entry to Vnukovo aviation meteorological database. Remote access to the database is provided via the MAMC Aviation Meteorological Database Service Terminal from the briefing room at Vnukovo-3. A representative of VIPPORT LTD requested the weather forecasts and actual weather for Moscow (Vnukovo), Moscow (Domodedovo), Paris (Le Bourget) and Paris (Charles de Gaulle) from the database.

As explained by the VIPPORT LTD representative he printed out the received weather information and handed it to the crew as a filled form. The form contained the following weather information: actual weather at 13:30 at Moscow (Vnukovo), Moscow (Domodedovo), Paris (Le Bourget) and Paris (Charles de Gaulle) and selective SPECI for 13:51 at Moscow (Domodedovo), SIGMET information 4 for Moscow FIA on 20.10.2014 valid from 11:00 to 14:00, weather forecasts for Moscow (Vnukovo) from 15:00 on 20.10.2014 to 15:00 on 21.10.2014, Moscow (Domodedovo) from 15:00 on 20.10.2014 to 21:00 on 21.10.2014, Paris

(Le Bourget) from 12:00 on 20.10.2014 to 12:00 on 21.10.14, Paris (Charles de Gaulle) from 12:00 on 20.10.2014 to 18:00 on 21.10.2014.

The TAF forecast for Moscow (Vnukovo) was formed and issued at 13:54 on 20.10.2014, effective from 15:00 on 20.10.2014 to 15:00 on 21.10.2014.

TAF UUWW 201354Z 2015/2115 VRB02MPS 0300 -RA FG OVC001 650010 TEMPO 2015/2106 1000 SHRA BR BKN003 SCT015CB FM210600 32005MPS 6000 BKN007 TEMPO 2106/2115 1200 SHRASN SCT004 SCT020CB=

Effective from 15:00 on October 20 to 15:00 on October 21, wind unstable, speed 2 m/sec, visibility 0300 m, light rain, fog, overcast, cloudbase 30 m, moderate icing from 30 m to cloud top, at times from 15:00 on October 20 to 06:00 on October 21 visibility 1000 m, shower rain, mist, clouds broken, cloudbase 90 m, scattered cumulonimbus clouds, cloudbase 450 m, from 06:00 on October 21, wind 320, 5 m/sec, visibility 6000 m, broken clouds, cloudbase 210 m, at times from 06:00 to 15:00 on October 21 visibility 1200 m, shower sleet, scattered clouds, cloudbase 120 m, scattered cumulonimbus clouds, cloudbase 600 m.

The TAF forecast for destination A/D Paris (Le Bourget) was formed and issued at 11:00 on 20.10.2014, effective from 12:00 on 20.10.2014 to 12:00 on 21.10.2014.

TAF LFPB 201100Z 2012/2112 26008KT 9999 SCT020 BKN100 PROB30 TEMPO 2012/2014 -RA BKN015 BECMG 2022/2024 BKN006 PROB40 2100/2104 3000 BR BKN004 BECMG 2105/2107 22015G25KT BKN016 TEMPO 2110/2112 25020G35KT=

Effective from 12:00 on October 20 to 12:00 on October 21, wind 260, speed 8 kt, visibility over 10 km, scattered clouds, cloudbase 600 m, broken clouds, cloudbase 3000 m, from 12:00 to 14:00 on October 20 30% probability of light rain, broken clouds, cloudbase 450 m, from 22:00 to 24:00 on October 20 gradually becoming broken clouds, cloudbase 180 m, from 00:00 to 04:00 on October 21 40% probability of visibility 3000 m, mist, broken clouds, cloudbase 120 m, gradually becoming from 0500 to 0700 on October 21 wind 220, 15 kt, gusting 25 kt, broken clouds, cloudbase 480 m, at times from 10:00 to 12:00 on October 21 wind 250, 20 kt, gusting 35 kt.

The TAF forecast for alternate destination A/D Paris (Charles de Gaulle) was formed and issued at 13:54 on 20.10.2014, effective from 12:00 on 20.10.2014 to 18:00 on 21.10.2014.

TAF LFPG 201100Z 2012/2118 26008KT 9999 SCT020 BKN100 PROB30 TEMPO 2012/2014 -RA BKN015 BECMG 2022/2024 BKN006 PROB40 2100/2104 3000 BR BKN004 BECMG 2105/2107 22015G25KT BKN016 TEMPO 2111/2116 26020G35KT PROB40 TEMPO 2112/2116 4000 SHRA SCT016TCU TX17/2013Z TN11/2024Z=

Effective from 12:00 on October 20 to 18:00 on October 21, wind 260, speed 8 kt, visibility over 10 km, scattered clouds, cloudbase 600 m, broken clouds, cloudbase 3000 m, from

12:00 to 14:00 on October 20 30% probability of light rain, broken clouds, cloudbase 450 m, from 22:00 to 24:00 on October 20 gradually becoming broken clouds, cloudbase 180 m, from 00:00 to 04:00 on October 21 40% probability of visibility 3000 m, mist, broken clouds, cloudbase 120 m, gradually becoming from 05:00 to 07:00 on October 21 wind 220, 15 kt, gusting 25 kt, broken clouds, cloudbase 480 m, at times from 10:00 to 12:00 on October 21 wind 250, 20 kt, gusting 35 kt, maximum temperature 17 degrees Celsius at 13:00 on October 20, minimum temperature 11 degrees Celsius at 24:00 on October 20.

At 17:00 new routine forecasts for all the above mentioned airdromes were issued effective from 18:00 on 20.10.2014. No requests from Vnukovo-3 to Vnukovo aviation meteorological database of weather forecasts an actual weather for Paris (Le Bourget) and Paris (Charles de Gaulle) were recorded after 13:59 20.10.2014.

Note: *In accordance with ICAO Annex 3 "Meteorological Service for International Air Navigation" Para 6.1.2 the issue of a new forecast by a meteorological office, such as routine aerodrome forecast, shall be understood to cancel automatically any forecast of the same type previously issued for the same place and for the same period of validity or part thereof.*

The forecasts of upper wind and upper-air temperature and of SIGWX phenomena issued by Roshydromet MAMC and present in the Vnukovo Aviation Meteorological Database were not requested by any person from Vnukovo-3, which is confirmed by archive data of entry events to the Vnukovo Aviation Meteorological Database from Vnukovo-3 via the MAMC Aviation Meteorological Database Service Terminal.

At 19:23 the crew of Falcon 50EX F-GLSA listened to ATIS information Papa for 19:16 that included the following weather information: surface wind 120, 3 m/sec, visibility 550 m, RVR 1400 m, light drizzle, fog, vertical visibility 70 m, temperature plus 1 degree Celsius, dewpoint plus 1 degree Celsius, QFE 728 mm mercury/971 hPa, moderate icing in clouds, landing forecast: at times visibility 200 m, fog, overcast, cloudbase 30 m.

At 19:33 the crew of Flight LEA074P contacted Delivery and confirmed they had received ATIS information Papa.

Within the time period from 19:16 to 19:57 the following ATIS information was transmitted but not listened to by the crew: information Quebec for 19:30, information Romeo for 19:45, information Sierra for 19:47 and information Tango for 19:57.

The RWY 1 weather measurement data were transferred from AMIS-RF to all working stations of Vnukovo ATC Center every minute. Below is the weather information reflected on the screens at air traffic controllers' working stations of Vnukovo ATC Center:

19:56: surface wind 120 3 m/sec, gusting 4 m/sec, circuit wind 250 7 m/sec, RWY 1 threshold visibility 350 m/RVR 1000 m, middle - visibility 1000 m/RVR 2000 m, terminal point - visibility 800 m/RVR 1800 m, light drizzle, fog, heading 06 - vertical visibility 30 m, temperature plus 1 degree Celsius, dewpoint plus 1 degree Celsius, moisture content 98%, heading 06, QFE 728/971, QNH 745/994.

19:57: surface wind 120 3 m/sec, gusting 4 m/sec, circuit wind -7 7 m/sec, RWY 1 threshold visibility 0350 m/RVR 1000 m, middle - visibility 1000 m/RVR 2100 m, terminal point - visibility 800 m/RVR 1900 m, light drizzle, fog, vertical visibility 60 m, temperature plus 1 degree Celsius, dewpoint plus 1 degree Celsius, moisture content 98%, heading 58 degrees, QFE 728/971, QNH 745/994, landing forecast: at times visibility 200 m, fog, overcast, cloudbase 30 m, RWY 1 braking action 0.5, 0.5, 0.5.

At 19:57, based on the measurements, as the cloudbase (vertical visibility) criterion was exceeded, the AMIS-RF system formed and issued a local special report recorded in the electronic AV-6 Log.

Before the aircraft takeoff at 19:56:40 the crew received weather information for 19:56 from the Tower Control taken from the screen: "...RWY 06 visibility 1000 m, vertical visibility 70 m, fog".

The fog at Moscow A/D (Vnukovo) and other Moscow A/Ds was formed in the daytime and was advective in nature. From time to time the fog density was changing and the surface visibility was changing accordingly. Simultaneously, low stratus clouds were observed forming drizzle. The drizzling precipitation was conducive to even higher light dispersion in the fog, which deteriorated visibility of objects and lights. The cloudbase of the stratus clouds at Moscow A/D (Vnukovo) at the time of the accident was recorded to be within 30 to 70 m.

The vertical visibility measurements in the advective fog at Moscow A/D (Vnukovo) were compatible with the cloudbase of the clouds producing the drizzle. The cloudbase or vertical visibility in the fog was measured in the area of the inner marker with both headings at a distance of about 900-1000 m from RWY 1 thresholds; the cloudbase is not subject to measurement in the middle of RWY 1.

Actual weather at Moscow A/D (Vnukovo) on 20.10.14:

- 19:57: visibility heading 58: front - 350 m, midpoint 1000 m, terminal point - 800 m, drizzle, fog, vertical visibility heading 58 degrees - 60 m, heading 238 degrees - 30 m.

- 19:58: visibility heading 58: front - 350 m, midpoint 1000 m, terminal point - 800 m, drizzle, fog, vertical visibility heading 58 - 70 m, heading 24 - 30 m.

Thus, by means of interpolation of the readings of instruments measuring cloudbase (vertical visibility) for heading 58 and heading 238, the cloudbase (vertical visibility) magnitude

in the RWY crossing and Tower area can be assumed to be approximately 45-50 m. The measured horizontal meteorological visibility in the area of the RWY crossing was 1000 m. According to the curve of horizontal visibility distribution under low stratus clouds in advective fog (Aviation Meteorological Conditions Forecasting Manual, L., Hydrometeoizdat, 1985, Figure 3.13) at a height of about 40 m (the control room in the Tower is at the height of 37 m) the visibility makes about 50% of the surface horizontal visibility. This, presumably, the visibility from the Tower Controller working place in the direction of the runway crossing could be about 500 m. There is no methodology for conversing horizontal visibility to inclined visibility from the Tower taking into consideration the runway lights.

At the time of the aircraft takeoff the following weather conditions were forecast at Moscow A/D (Vnukovo):

The TAF forecast for Moscow (Vnukovo) issued at 16:54 on 20.10.2014:

TAF UUWW 201654Z 2018/2118 VRB02MPS 0300 -RA FG OVC001 TEMPO 2018/2107 1000 SHRA BR BKN003 SCT015CB FM210700 32005MPS 6000 BKN007 TEMPO 2107/2118 33006/11MPS 1200 SHRASN SCT004 SCT020CB=

Valid from 18:00 on October 20 to 18:00 on October 21: wind unstable, speed 2 m/sec, visibility 0300 m, light rain, fog, overcast, cloudbase 30 m, at times from 18:00 on October 20 to 07:00 on October 21 visibility 1000 m, shower rain, mist, clouds broken, cloudbase 90 m, scattered cumulonimbus clouds, cloudbase 450 m, from 07:00 on October 21, wind 320, 5 m/sec, visibility 6000 m, broken clouds, cloudbase 210 m, at times from 07:00 to 18:00 on October 21 wind 330, 6 m/sec, gusting 11 m/sec, visibility 1200 m, shower sleet, scattered clouds, cloudbase 120 m, scattered cumulonimbus clouds, cloudbase 600 m.

At the time of the accident at 19:58 the AMIS-RF system recorded the following weather:

19:58: surface wind 120 3 m/sec, gusting 5 m/sec, heading 58 visibility 350 m/RVR 1000 m, midpoint - visibility 1000 m/RVR 2000 m, heading 238 degrees - visibility 800 m/RVR 1800 m, light drizzle, fog, heading 58 - vertical visibility 70 m, heading 238 degrees vertical visibility 30 m, temperature plus 1 degree Celsius, dewpoint plus 1 degree Celsius, moisture content 98%, heading 58 degrees, QFE 728/971, QNH 745/994.

After the accident at 19:58, there was no request to the meteorological office for non-routine observation after the Emergency Landing (Alert) signal from the aerodrome shift supervisor, in violation of the "Instruction on meteorological service at Vnukovo A/D".

At 20:36 the aerodrome shift supervisor requested the chief observation point meteorologist via the speakerphone to provide weather report for 19:57. At 20:37 the meteorologist used the speakerphone to read to the shift supervisor the special weather report for Vnukovo A/D from the AV-6 Log.

Note: *As it follows from the explanations of the meteorologists on duty, about 40 minutes after they had heard the explosion and seen the fire through the window, the aerodrome shift supervisor requested aerodrome actual weather for 19:57 via the speakerphone. As there had been a special weather report formed at 19:57 recorded in the AV-6 Log, they provided the requested information to the shift supervisor immediately via the speakerphone.*

The actual weather at Moscow A/D (Vnukovo) at the time of the aircraft departure was compatible with the forecast. All parameters of the weather forecasts for Vnukovo A/D proved to be true.

The weather conditions did not impede the aircraft departure though were quite complicated.

1.8. Aids to Navigation, Landing and ATC

1.8.1. Radio Navigation Service

The radio navigation service at Vnukovo A/D is provided by the Radio Navigation Service of Vnukovo ATC Center, Moscow ATM Center, State ATM Corporation, which is a structural department of Vnukovo ATC Center, Moscow ATM Center, State ATM Corporation. Certificate of Compliance № AHO.II.000495, issued by FATA on 10.06.2014. Valid till 10.06.2016.

The operation of the Radio Navigation Service of Vnukovo ATC Center, Moscow ATM Center, State ATM Corporation was conducted in accordance with the "Provision on the Air Traffic Service of Vnukovo ATC Center" approved by order № 303 of the Director of Moscow ATM Center, State ATM Corporation as of 01.04.2014.

1.8.1.1. Navigation and Landing Aids

DVOR/DME (113.7 WNK). The DVOR is located 175 m to the south of RWY 1 centerline, longitudinal distance from threshold 06 of RWY 1 is 984 m, from threshold 24 of RWY 1 - 2516 m, it is also located 272 m to the west of RWY 2, longitudinal distance from threshold 01 of RWY 2 is 87 m and from threshold 19 of RWY 2 - 2973 m. Flight check was accomplished on 09.10.2014 by the crew of a Beechcraft King Air 350i RA-02814 operated by State ATM Corporation.

ADF-2000. The 7.14 m tall ADF-2000 antenna is located 184 m to the south of RWY 1 centerline, longitudinal distance from threshold 24 of RWY 1 is 2826 m, from threshold 06 of

RWY 1 - 674 m. Flight check was accomplished on 16.09.2014 by the crew of an An-26 aircraft tail number 26521 operated by Flight Checks and Systems Ltd.

ADF-95. The 48.95 m tall ADF-95 antenna is located on roof of the Tower, 467 m to the south of RWY 1 centerline, longitudinal distance from threshold 24 of RWY 1 is 1269 m, from threshold 06 of RWY 1 - 2230 m, used for servicing the Approach Control (Sector Vnukovo Approach 1). The Landing Control uses the superposed ADF-95 bearing. Flight check was accomplished on 27.05.2014 by the crew of an An-26 aircraft tail number 26521 operated by Flight Checks and Systems Ltd.

Navigation and Landing Aids, RWY 1 (06/24)

There are two radio locators with markers (heading 58 and 328 degrees magnetic) to support aircraft descent and approach:

Locator at RWY 06 (294 GT), located along the RWY centerline 895 m away from the threshold;

Locator at RWY 24 (852 OB), located along the RWY centerline 1033 m away from the threshold;

The locator alternate frequency is 355 kHz.

The flight checks were accomplished on 16.09.2013 by the crew of an An-26 aircraft tail number 26521 operated by Flight Checks and Systems Ltd.

There are also two ILS systems: ILS-200.1, landing heading 58 degrees magnetic, including the localizer located along the RWY centerline, 400 m behind threshold 24 of RWY 1, the glide path beacon and DME beacon (RMD-90NP), located 288 m behind threshold 06 of RWY 1 and 120 m to the right of the RWY centerline. The glideslope angle is 3°00'.

The flight check was accomplished on 08.10.2014 by the crew of a Beechcraft King Air 350i RA-02814 operated by State ATM Corporation.

ILS-200.1, landing heading 238 degrees magnetic, including the localizer located along the RWY centerline, 450 m behind threshold 06 of RWY 1, the glide path beacon and DME beacon (RMD-90NP), located 335 m behind threshold 24 of RWY 1 and 120 m to the left of the RWY centerline. The glideslope angle is 3°00'.

The flight check was accomplished on 08.10.2014 by the crew of a Beechcraft King Air 350i RA-02814 operated by State ATM Corporation.

Navigation and Landing Aids, RWY 2 (01/19)

There are two radio locators with markers (heading 013 and 193 degrees magnetic) to support aircraft descent and approach:

Locator at RWY 01 (949 OE), located along the RWY centerline 951 m away from the threshold;

Locator at RWY 19 (914 SX), located along the RWY centerline 891 m away from the threshold;

The locator alternate frequency is 725 kHz.

The flight checks were accomplished on 16.06.2014 by line aircraft.

There are also two ILS systems: ILS-90, landing heading 013 degrees magnetic, including the localizer located along the RWY centerline, 400 m behind threshold 19 of RWY 2, the glide path beacon and DME beacon (RMD-90NP), located 282 m behind threshold 01 of RWY 2 and 134 m to the left of the RWY centerline. The glideslope angle is 3°00'. Flight check was accomplished within May 20-23, 2014 by the crew of an An-26 aircraft tail number 26521 operated by Flight Checks and Systems Ltd.

ILS-90, landing heading 193 degrees magnetic, including the localizer located along the RWY centerline, 224 m behind threshold 01 of RWY 2, the glide path beacon and DME beacon (RMD-90NP), located 283 m behind threshold 19 of RWY 2 and 125 m to the right of the RWY centerline. The glideslope angle is 3°00'.

Flight check was accomplished within May 20-23, 2014 by the crew of an An-26 aircraft tail number 26521 operated by Flight Checks and Systems Ltd.

1.8.2. Airfield Surveillance Radar

The Terma Scanter 2001 Airfield Surveillance Radar located near Vnukovo-1 ramp, between TWY M1 and TWY B5, 604 m to the north of RWY 1 centerline and 359 m to the south-east of RWY 2 centerline.

As per Para 5.1, Chapter 6 of the AON-92:

- for CAT I precision approach RWY an airfield surveillance radar system is not required;

- for CAT II precision approach RWY an airfield surveillance radar system is recommended;

- a CAT III precision approach RWY shall be equipped with an airfield surveillance radar system (FAR-116 contains a similar requirement);

Note: *As per Instruction on Flight Operations in Vnukovo A/D Terminal Area*

RWY 1 is equipped for the following types of approach:

- heading 058 degrees magnetic - CAT I/CAT II precision approach;

- heading 238 degrees magnetic - CAT I/CAT II precision approach;

RWY 2 is equipped for the following types of approach:

- heading 013 degrees magnetic - CAT I precision approach;

- heading 193 degrees magnetic - CAT I/CAT II precision approach;

The Terma Scanter 2001 Airfield Surveillance Radar type 262183-603 with antenna system 21'-CP-F № 259460-431 was manufactured by Terma A/S-Radar Systems (Denmark) in 2008.

Terma A/S-Radar Systems (Denmark) is a holder of Type Certificate № 372 issued by Airdrome and Equipment Certification Commission, IAC on 21.12.2004 for the Terma Scanter 2001 Airfield Surveillance Radar type 262183-010, including antenna system 21'-CP-F 259460-031 or 21'-CP-I 259460-041.

On 15.11.2010 Airdrome and Equipment Certification Commission, IAC issued Supplement 2 to the Type Certificate № 372 of 21.12.2004, extending the validity of the Type Certificate № 372 to Terma Scanter 2001 Airfield Surveillance Radar Type 262183-603 with antenna system 21'-CP-F 259460-431 with special limitations retained.

Terma Scanter 2001 Airfield Surveillance Radar was introduced to service at Moscow A/D (Vnukovo) by Order № 725 of Moscow ATM Center Director, ATM State Corporation as of 06.09.2013.

The Airfield surveillance and control subsystem A3000 type 00-06-02 of an A-SMGCS system, ID 00-06-32 was manufactured by HITT (the Netherlands) in 2008.

HITT - Holland Institute of Traffic Technology is a holder of Type Certificate № 373 issued by Airdrome and Equipment Certification Commission, IAC on 21.12.2004 for the type construction of the airfield surveillance and control subsystem A3000 type 00-06-02 of an A-SMGCS system with SuSE Linux 8.2. operation system and application software.

The airfield surveillance and control subsystem A3000 type 00-06-02 of an A-SMGCS system was introduced to service at Moscow A/D (Vnukovo) by Order № 726 of Moscow ATM Center Director, ATM State Corporation as of 06.09.2013.

The Terma Scanter 2001 Airfield Surveillance Radar is operated at Moscow A/D (Vnukovo) on the basis of Certificate № AHO.O 004264 issued by FATA on 27.09.2013 valid till 27.09.2015. In the Applicability section of the certificate in question it is stated: "Navigational equipment. Detection and location of the aircraft and other objects, located at the airfield with the display of information to ATM authorities".

Note: *As per FAR "Flight Checks of Ground Aids to Radio Navigation , Communication and Lighting Equipment in Civil Aviation" (Order № 1 of Russian Ministry of Transport as of 18.01.2005), no flight check of the airfield surveillance radar is required.*

The location and general view of the airdrome surveillance radar is shown on Figure 3 and Figure 4.



Figure 3. Location of the airfield surveillance radar (shown by arrow)at Moscow A/D (Vnukovo), satellite picture

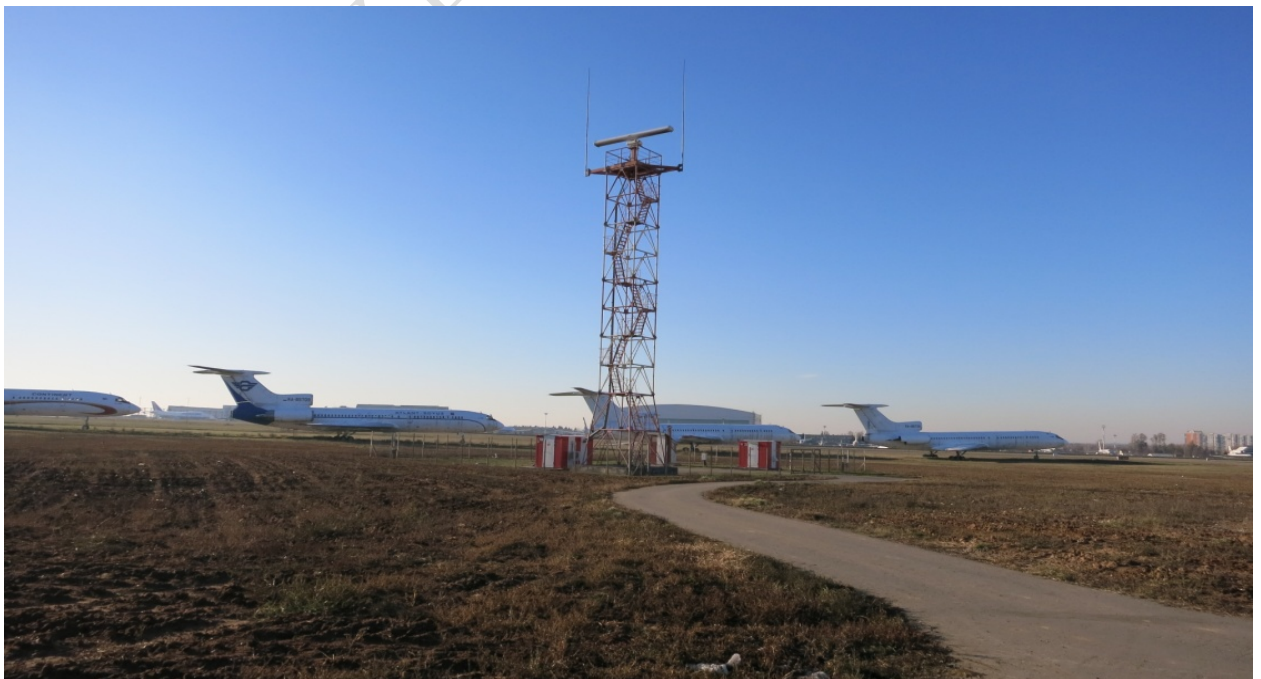

Figure 4. General view of the airfield surveillance radar at Vnukovo airdrome

Within 12.09.2013 to 13.09.2013, upon Resolution № 32-p of the Head of Vnukovo ATC Center "On determination of the airdrome surveillance radar visibility areas at RWY 1 and adjacent TWYs" as of 09.09.2013 a check was accomplish to ensure the airfield surveillance radar system is in compliance with the ANO-92, FAR and is suitable for use in ATM.

The checked airdrome surveillance radar RWY and TWY visibility areas are shown on Figure 5 and Figure 6.

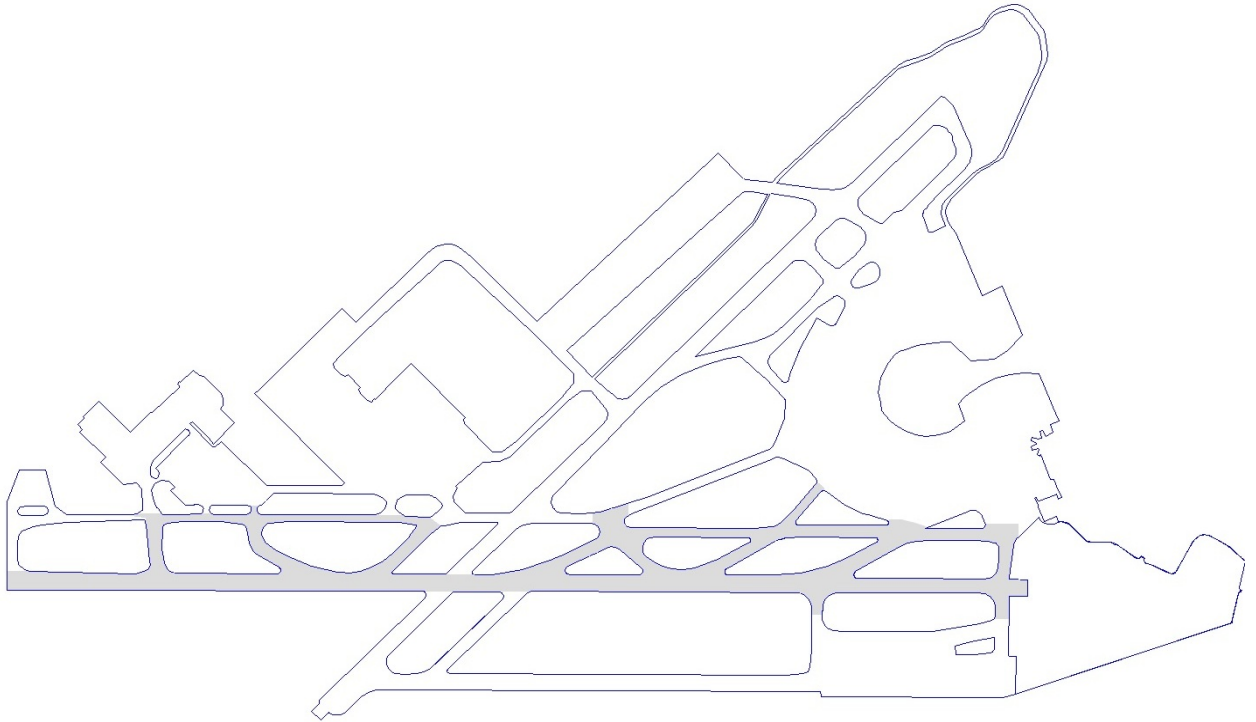

Figure 5. Parts of Vnukovo RWYs and TWYs checked (painted grey)

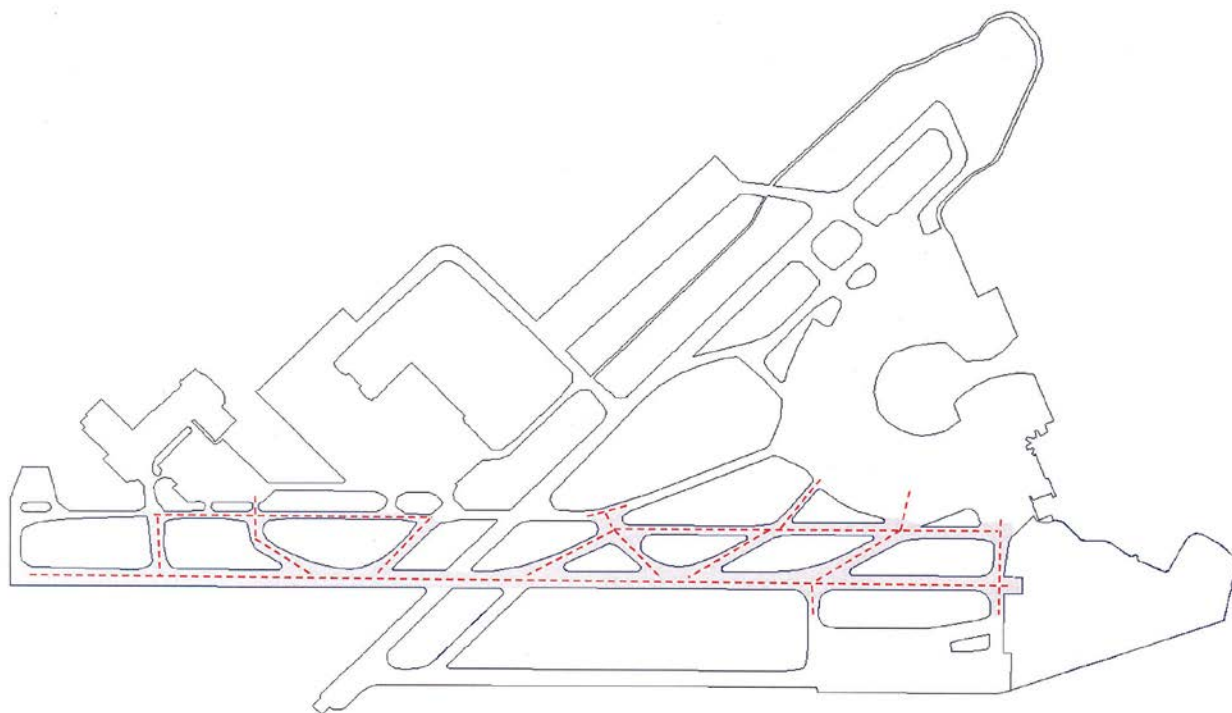

Figure 6. Airdrome surveillance radar visibility chart made from a car

Conclusion made upon the completion of the check, approved by Head of Vnukovo ATC Center as of 17.09.2013:

1. The Terma Scanter 2001 airfield surveillance radar MSN № 262183-603 ensures detection of aircraft and vehicles located on the tested RWYs and TWYs with the required probability as per applicable regulations.

2. The distance and azimuth resolution capabilities of the Terma Scanter 2001 airfield surveillance radar MSN № 262183-603 in the all-round surveillance mode within 2 km comply with the manufacturer's documentation and are not lower than required by the regulations.

3. The indicators at controllers' and LAZ technical control working stations reflect all the information as required by regulations (outlines of runways, taxiways, ramps, aircraft and vehicles coordinates).

On 20.10.2014 the Terma Scanter 2001 Airfield Surveillance Radar operated without any complaints from controllers of Vnukovo ATC Center. Within the time of the system being in service, two faults of the system have been recorded in the Log of Radio, Lighting and Communication Aids Operation: on 03.11.2013 and 19.01.2014.

Note: *Log of Radio, Lighting and Communication Aids Operation, Vnukovo ATC Center:*

1. "03.11.13 02:15 UTC. There is no locator information from the Terma Scanter 2001 radar on the screens".

Server is rebooted, operation OK".

2. "19.01.2014 10:15-17:40 Many false targets on the surveillance radar indicator along RWY 01/19 and on RWY 06/24. Meanwhile, a Gulfstream 4 aircraft is not visible at A3 shift supervisor's indicator screen".

"23.01.2014 06:10. To records of 19.01.2014. False targets appear on the indicator due to multiple reflections from the aircraft standing at M3 and A3. To avoid similar situations please prevent putting large aircraft at M3, A3, M4, B4, B2. Lead Engineer, Radio Navigation".

1.8.2.1. Conflict Detection Settings of TRADIS as of 20.10.2014¹³

Conflict Detection Functionality

Objects detected by the surveillance radar are shown as tracks on the indicators (screens) of the TRADIS system (airfield surveillance radar indicators). Aircraft identified by the system can have a label with additional information. For inbound traffic with a transponder the identification has already taken place and as a result the label is connected automatically to the track number. Detected objects that have not been identified are followed as tracks with numbers randomly assigned by the system (if out of the object echo signal with its subsequent regeneration the system assigns another track numbers to the same objects). Unidentified traffic label information needs to be manually connected to the track number.

Note:

The A3000 sub-system at Vnukovo AP is not equipped with MLAT/ADSB. So on the ground there is no automatic identification even if the aircraft (or other airport vehicle) is equipped with an operational transponder operating in the RBS mode. The system configuration is such that outbound traffic needs to be identified manually. Inbound traffic that is already identified in the airspace will continue with identification on the ground, even without availability of transponder info. If afterwards the signal from this object is lost regaining identification will require manual input from the controller.

The TRADIS indicators are installed at the working positions of ground controller, departure controller, landing controller and shift supervisor in the ATC Control Room. Identical radar information is reflected at all working positions.

¹³ This chapter was written with use of HITT documentation "TRADIS. Operational Manual. Edition 2011-11-21.

The traffic situation display settings can be selected individually on each working position. The selected settings are valid for the individual working position and do not affect the traffic situation picture on other working positions, excluding the working position of departure ATC controller and landing controller. This is because there is only one TRADIS system unit at the working position of departure ATS controller that forwards the same information (including the information indication settings) via a splitter (Figure 7) to TRADIS indicators on working positions of Departure ATS, Departure ATC and Landing controller. The TRADIS indicator information indication settings on the mentioned working positions are the same and consistent with the information indication settings on the working position of the Departure ATS controller. There is no possibility to change indication settings on the Departure ATC working position.

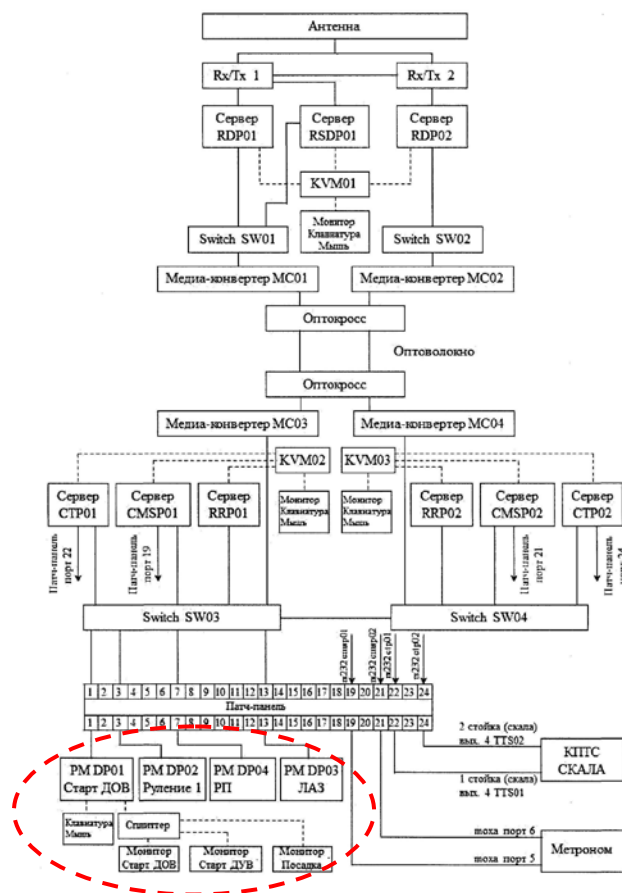

Figure 7. TRADIS and airfield surveillance radar system flowchart

The configuration of the splitter and two extra monitors was deployed by local technicians subsequent to the delivery and installation of the system. At system delivery the configuration was three controller working positions each of which was equipped with a keyboard and mouse. It was not possible to determine having the available information if the working positions were initially equipped with speakers. According to the system manufacturer's information the speakers were included into the delivery set (which is confirmed by the list of hardware in the Project Version Description Document for PJSC Vnukovo Airport,

00-06-32.VDD – 2008-08-22 – Volume 1 of 1 Rev. 05 Approved – 2012-01-24, Page 23). However, the representatives of Vnukovo AP do not confirm the presence of speakers as delivered and refer to the List of Deliverable Items for the A-SMGCS Project for Vnukovo AP, Ident 00-06-32, Date – 2005-08-29. Page 5 of this List specifies that a keyboard and mouse is delivered for each working position, while the speakers are not mentioned.

The system provides a number of control functions including the setting of alerts for Reserved Lines crossing, Runway Incursion Monitoring, Taxiway Collision Monitoring and Area Penetration Monitoring.

The conflict detection functionality can be switched on or off individually for each working position except the Departure ATC and Landing Controller:

RIM - Runway Incursion Monitoring;

TCM - Taxiway Collision Monitoring;

APM - Area Penetration Monitoring.

Note: *RIM alert consists of two levels: a pre-alert and an alert as such. The pre-alert (on blue) appears as two identified objects on the runway's closing speed reaches 5 m/sec. As the closing speed reaches 15 m/sec the sound alert is triggered and the message background turns amber. For each alert type (RIM, TCM or APM) the system has an individual sound file. By default, each sound file contains one short-term tone (no longer than 0.1 sec). These alerts (format and/or duration) can be modified by the system operator's technical/maintenance personnel (A3000 system Maintenance Manual Para 8.3.17). At the time of the accident the speakers were not installed on the working stations of Departure and Ground controller, as well as at the working station of shift supervisor, that is the sound signal could have been replayed only with the system unit speaker. At that moment the keyboard/mouse control at the departure controller's system unit was connected to the Departure ATS working position.*

When the RIM mode is on, the system notifies controllers as follows:

- in case there are two labeled tracks on the runway and they are approaching each other at a speed of 5 m/sec the TRADIS indicator shows in the alert list a blue alert message with the numbers of the conflicting tracks. The conflicting tracks are indicated with light blue RI symbols. As the speed of closing in gets more than 15 m/sec the alert message and RI symbols

turn from light blue to amber (Figure 8). As the speed of closing in gets slower the alert message turns light blue. As the conflicting tracks diverge or a track number disappears, or the speed of closing in gets less than 5 m/sec, the alert disappears and is not saved in the alert list. The alert message disappears regardless of its being confirmed by a mouse pointing device click.

The controller is also able to activate and de-activate the different Reserved Lines (Figure 8) that are configured in the system. Reserved Lines can be activated and de-activated in both directions (towards and away from the runway). As the Reserved Line is crossed by a labeled track the controller is notified by a red message in the alert list (Figure 8) showing the track number and the crossed Reserved Line. In case the track is identified the message in the alert lists shows the call sign instead of track number. If other Reserved Lines are crossed, the alerts are added to the list. The labels of the tracks, which are involved in the conflict situation, are indicted with red LC symbols. The alert message remains in the alert list until the alert has been acknowledged. Alerts can be acknowledged by clicking on the alert name in the alert list or clicking on the alert in the track label (using the mouse).

When an inserted alert message in the list causes the list to grow below the bottom of the screen border, the list is automatically moved up to present all items in the list.

The alert list disappears when all alert messages are removed from the list.

The controller is not able to expand the list or position of the Reserved Lines from an individual working position.

Technical personnel can add reserved lines to the list and place them at any place within the radar visibility.

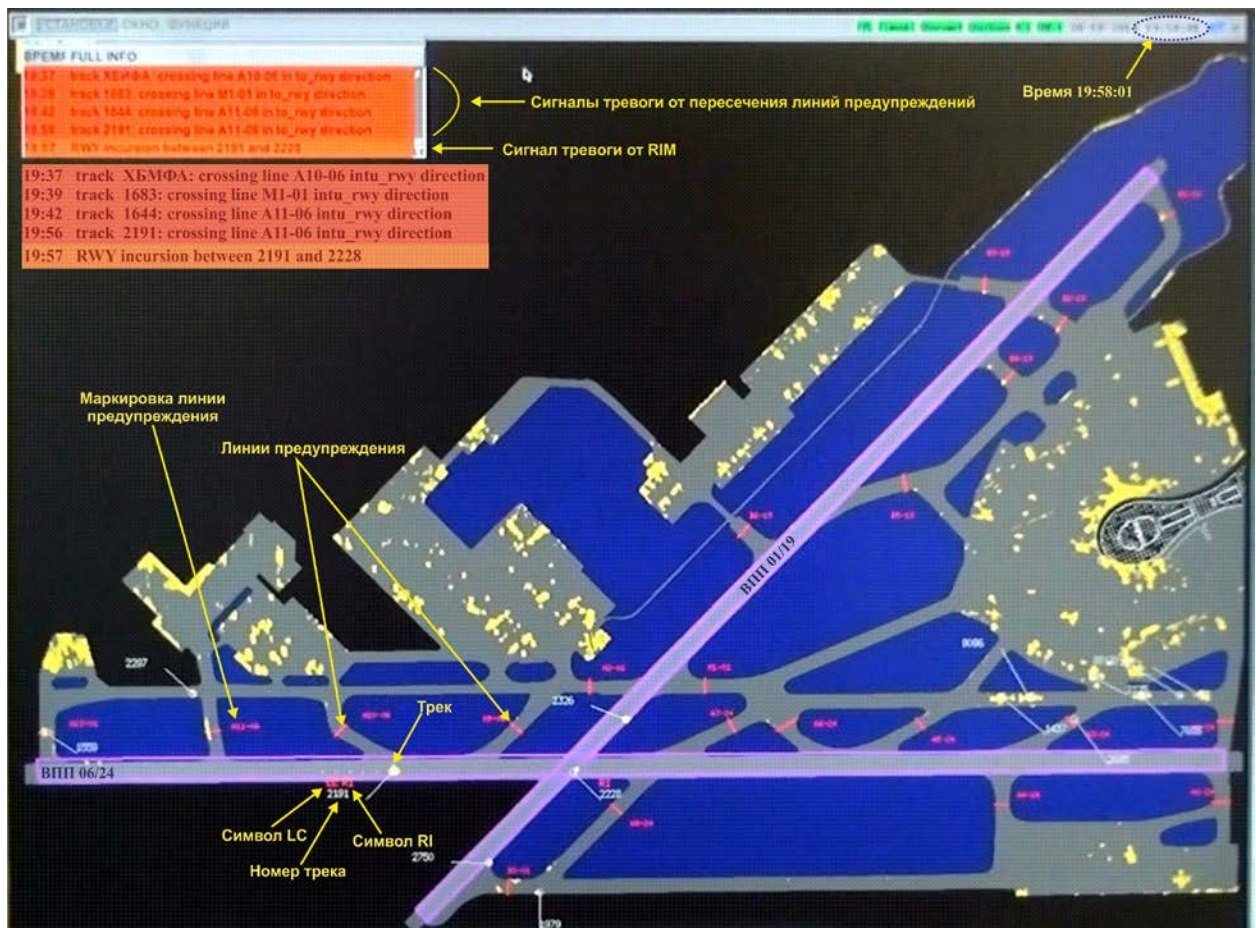

Figure 8. Alert message and reserved lines in the indicator

The investigation team notes the following:

- the corporate documentation of Vnukovo ATC Center does not contain any guidance or recommendations for the controllers as to setting and usage of TRADIS with regard to conflict detection (how different alert modes are switched on)¹⁴;
- the actual settings of the system on the accident day did not contain any reserved lines in the area of the runway intersection;
- the settings of the reserved lines list (adding or deleting lines) had not been changed since the system was taken into service.

1.8.2.2. Actual Conflict Detection Settings of TRADIS (A-SMGCS) at Controllers and Supervisor's Working Positions on 20.10.2014

With use of the archive data for 20.10.2014 the actual settings of the conflict detection functionality were determined and the tracks movements on the TRADIS screens on controllers and supervisor's working positions were replayed.

¹⁴ There are no regulations on setting the system at individual working positions.

Settings on the Ground Controller Working Position

1. No RIM, TCM or APM alert monitoring on (Figure 9).

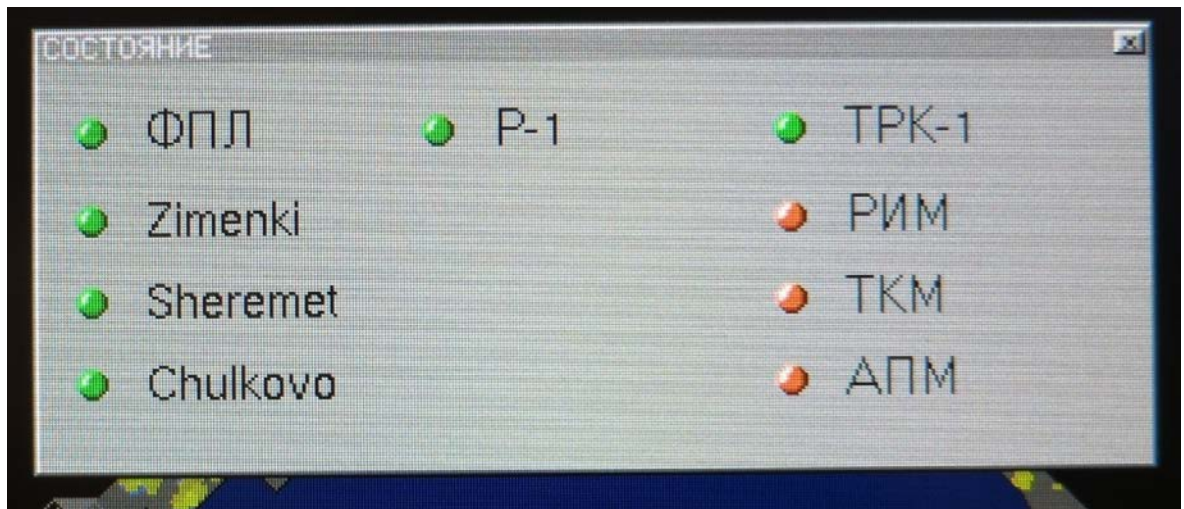

Figure 9. System Status Window at Ground Controller Working Position

Note:

1. *TRADIS Operational Manual. 10.1 System Status*

The system status window is divided into two parts. The upper part¹⁵ shows the status of the sub-systems. The status with the following sub-systems are shown:

FPL - Flight Plan System;

R-1 - Radar video of radar 1;

TRK-1 - Tracking of radar 1;

A green indication represents a correct situation. A red indication represents that the sub-system is not present at the moment.

The lower part shows the status of the alert monitoring. The following alert monitoring statuses are shown: RIM - Runway Incursion Monitoring, TCM - Taxiway Collision Monitoring, APM - Area Penetration Monitoring.

When it is enabled, a green indication is shown. When a specific alert monitoring is disabled, a red indication is shown, and no alerts of this type are generated.

2. The green indication of Zimenki, Sheremet and Chulkovo means that TRADIS used radar information from Zimenki, Sheremet and Chulkovo radar stations.

2. The activation of specific Reserved Lines is shown in Figure 10.

¹⁵ As written in the User Guide.

Not activated were the following reserved lines: A1-24 (to-RWY)¹⁶, A11-06 (to-RWY), A13-06 (to-RWY), A7-24 (to-RWY), A8-24 (to-RWY), B1-19 (to-RWY), B2-19 (to-RWY), B3-19 (to-RWY), B5-19 (to-RWY), B6-19 (to-RWY) and M2-01(to-RWY).

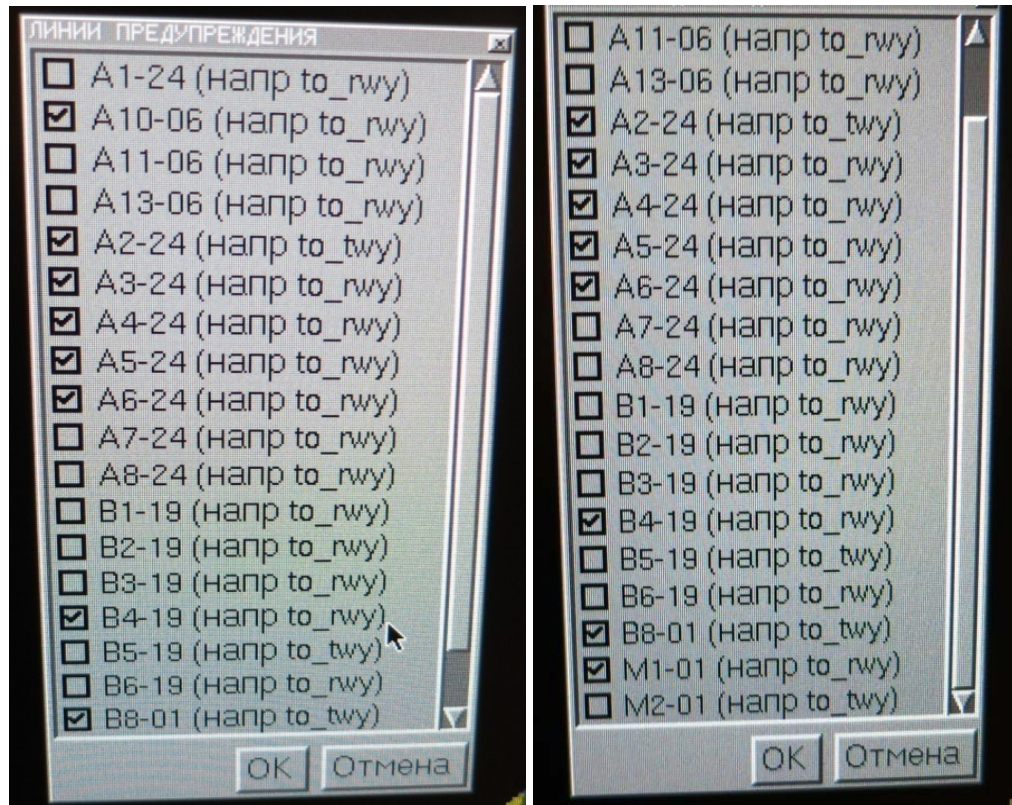

Figure 10. Reserved Lines (ticked lines are activated) at Ground Controller WP

3. The activation of technical chart with Reserved Lines is shown in Figure 11.

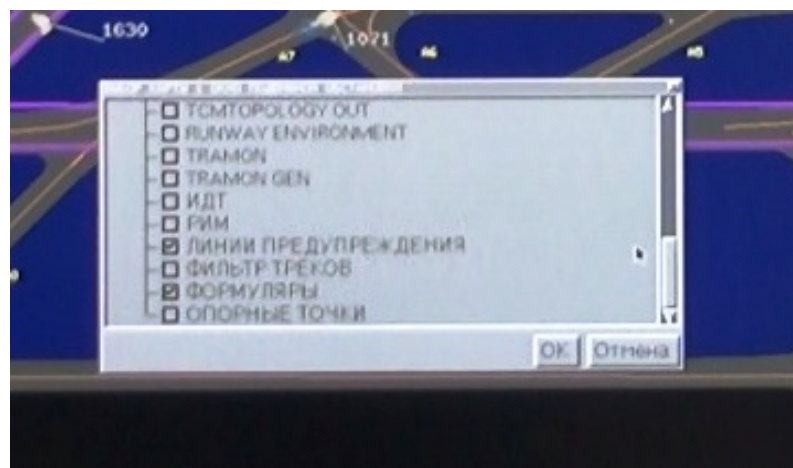

Figure 11. Technical chart status with Reserved Lines at Ground Controller WP. Chart activated (ticked)

4. The status of system technical charts is shown in Figure 12. The charts are not activated. Thus, though the Reserved Lines were on (alert messages appearing) but their indication on the screen was disengaged.

¹⁶ Direction: towards the RWY.

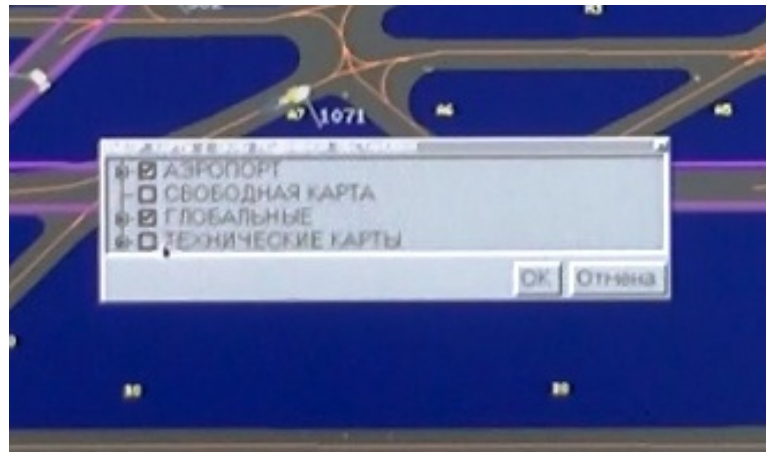

Figure 12. System technical charts status at Ground Controller Working Position. Charts are not activated (unticked)

5. The TRADIS indicator before the accident is shown in Figure 13 and Figure 14.

Note: *In Figure 14 the reference image that is displayed on the indicator is represented. To increase the legibility of the text and the objects identification at Figure 13 and all the subsequent ones with the indicators images, the investigation team additionally placed a typed text of the displayed messages and the objects identification.*



Figure 13. TRADIS indicator on ground controller's working position before the accident with additional information from the investigation team

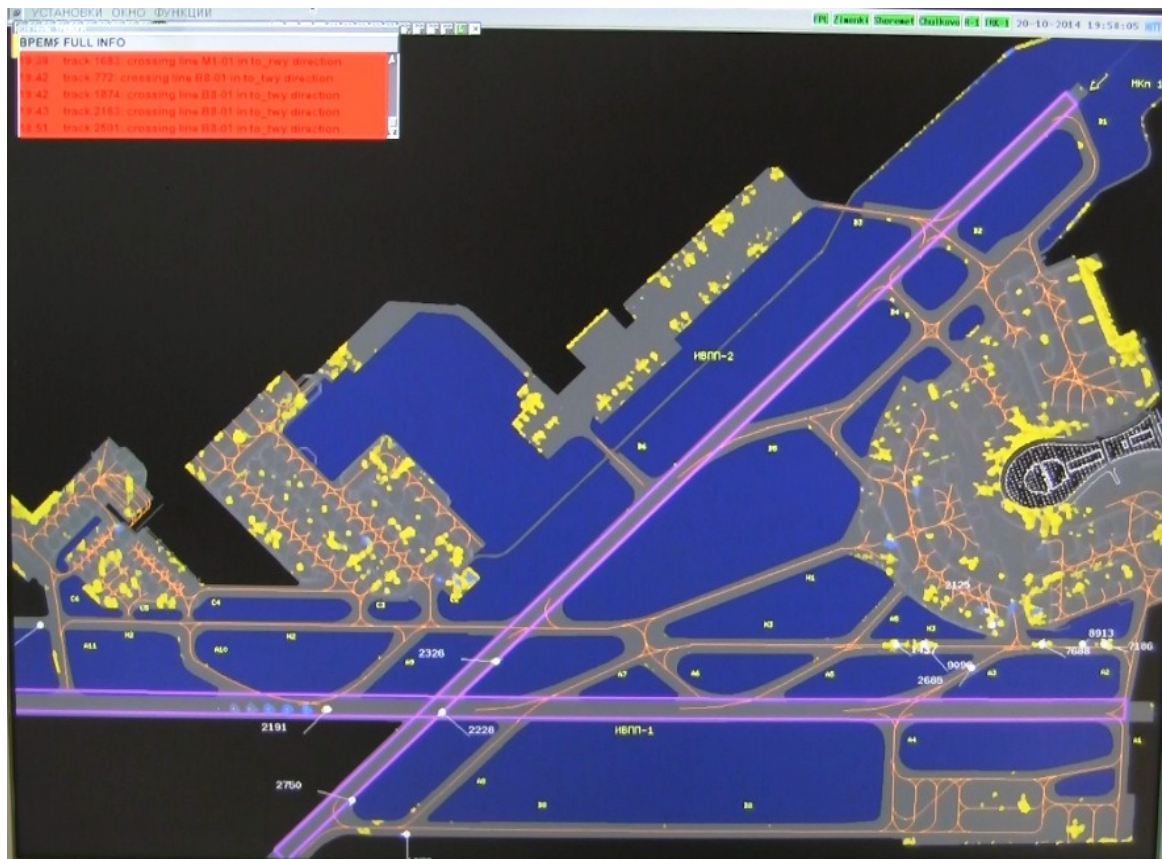

Figure 14. TRADIS indicator on ground controller's working position before the accident

The indicator does not show the Reserved Lines as the system technical charts were deactivated.

The indicator shows alerts of Reserved Lines crossing:

- at 19:39 1683 crossed M1-01;
- at 19:42 772 crossed B8-01;
- at 19:42 1878 crossed B8-01;
- at 19:43 2163 crossed B8-01;
- at 19:51 2501 crossed B8-01;

where:

- 772, 1878, 2163 and 2501 are numbers of tracks given by the system to the airdrome vehicles.

- 1683 is the number of track given by the system to another aircraft.

At 19:56 the track number 2191 crossed A11-06 (the Falcon 50 Falcon 50EX F-GLSA was taxiing to the line-up position) followed by no alert caused by crossing the reserved line, as the A11-06 (to-RWY) reserved line was not activated.

Thus the status of TRADIS at the ground controller working position was as follows:

- alert monitoring for all three type of alerts was off;
- most of reserved lines directed towards the runway were on;

- Reserved Lines were not displayed as the system technical charts were deactivated;
- there were 4 alerts on the airfield surveillance radar indicator as the B8-01 reserved line was crossed by snowplows within 19:42 to 19:51 and 1 alert as the M1-01 reserved line was crossed by a taxiing aircraft at 19:39. Neither of the alerts was confirmed (clicked) by the controller.

Settings on the ATC Departure Controller Working Position

1. RIM, TCM or APM alert monitoring off (Figure 15).

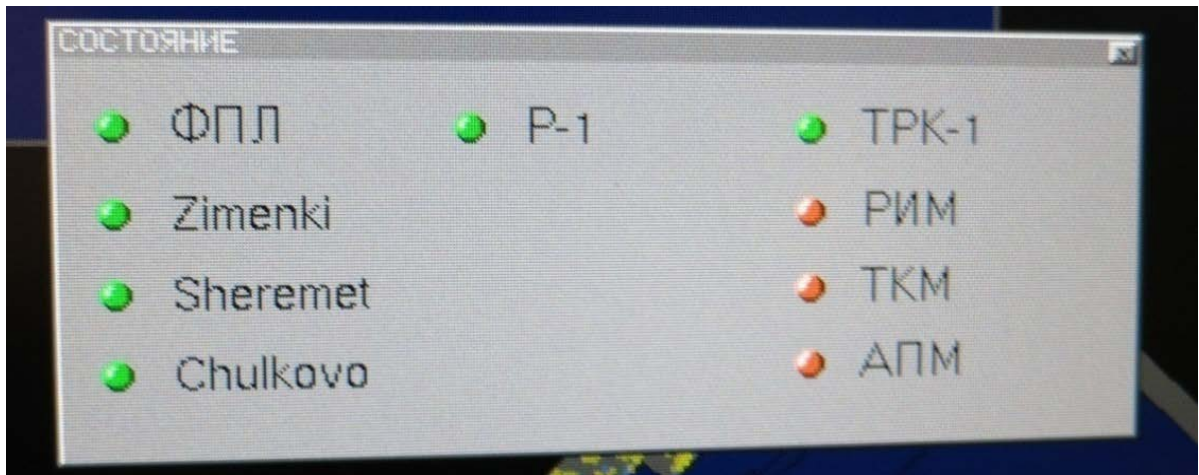

Figure 15. System Status Window at Departure ATS and Departure ATC working positions

2. The activation of specific Reserved Lines is shown in Figure 16.

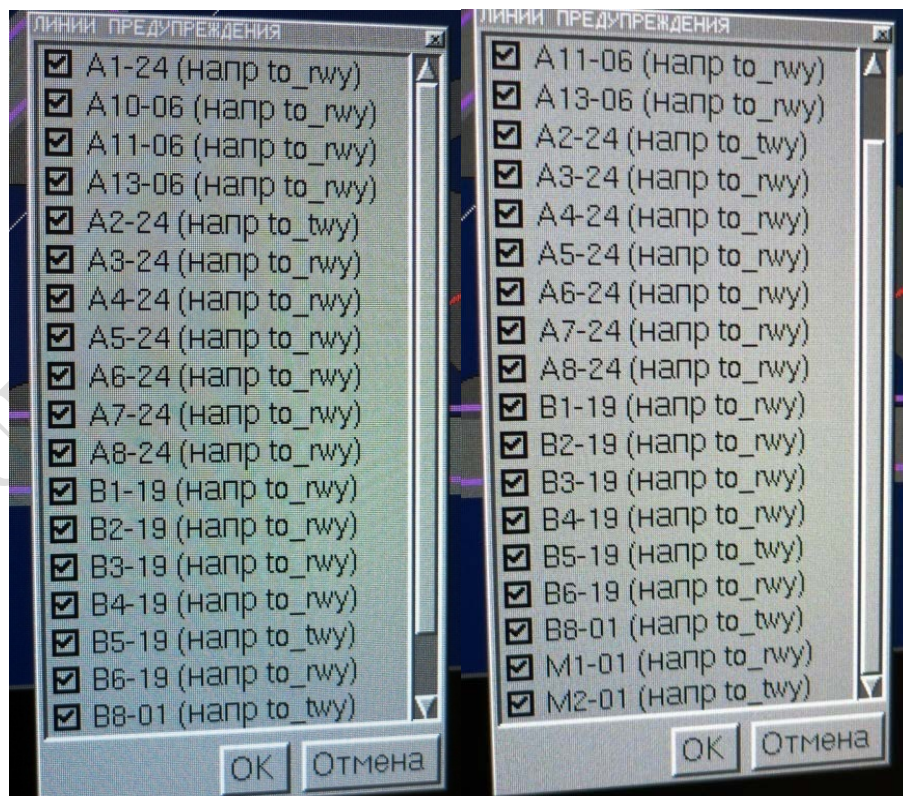

Figure 16 Reserved Lines at Departure ATS and Departure ATC working positions (ticked lines are activated)

3. Status of the technical chart with Reserved Lines is shown in Figure 17. The chart is activated (ticked).

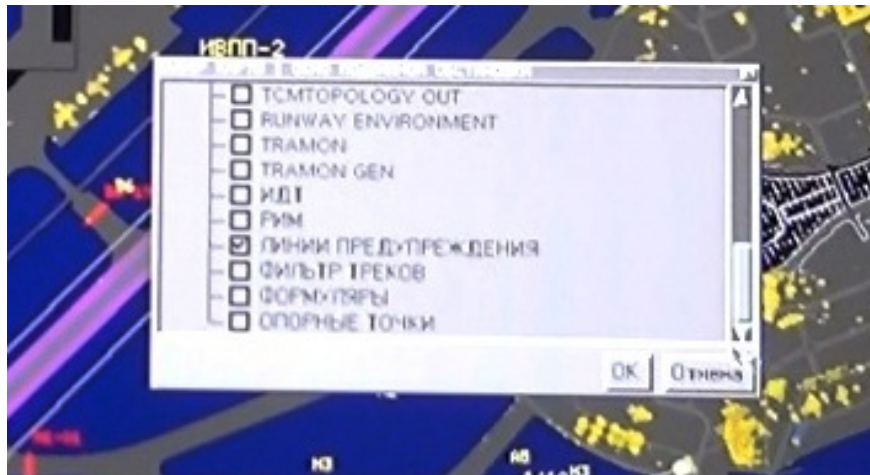

Figure 17. Technical chart status with Reserved Lines at Departure ATS and Departure ATC working positions The chart is engaged (ticked)

4. Status of the system technical charts is shown in Figure 18. The charts are activated.

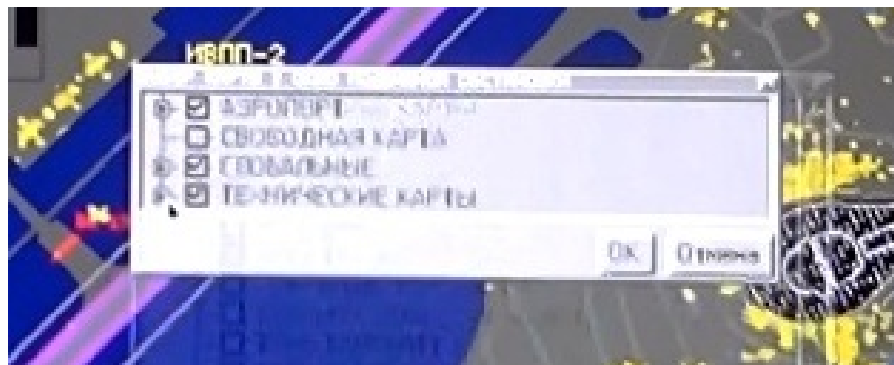

Figure 18. System technical charts status at Departure ATS and Departure ATC working positions. Charts are engaged (ticked)

5. The airfield surveillance and control system indicator view before the accident is shown in Figure 19.



Figure 19. TRADIS indicator on departure ATC controller's working position before the accident

The indicator shows alerts of Reserved Lines crossing:

- at 19:42 772 crossed B8-01;
- at 19:42 1874 crossed B8-01;
- at 19:43 2163 crossed B8-01;
- at 19:51 2501 crossed B8-01;
- at 19:56 2191 crossed A11-06;

where:

- 772, 1874, 2163 and 2501 are numbers of tracks given by the system to the airdrome vehicles.

- 2191 is the number of track given by the system to the Falcon 50EX F-GLSA aircraft.

Thus the status of TRADIS at the departure ATS (ATC) controller working position was as follows:

- alert monitoring for all three type of alerts was off;
- all reserved lines directed towards the runway were on;
- there were 4 alerts on TRADIS as the B8-01 reserved line was crossed by the airdrome vehicles within 19:42 to 19:51 and 1 alert as the A11-06 reserved line was crossed by the

Falcon 50EX F-GLSA aircraft at 19:56 as it was taxiing to the line-up position. At the time of the accident the air traffic was controlled from the Departure ATC working position. It was impossible to confirm the alerts from the Departure ATC controller's WP. Due to the configuration peculiarities described above it was only possible to acknowledge the alerts from the Departure ATS WP.

Settings on the Supervisor's Working Position

1. TCM alert monitoring off, RIM and APM alert monitoring on (Figure 20).

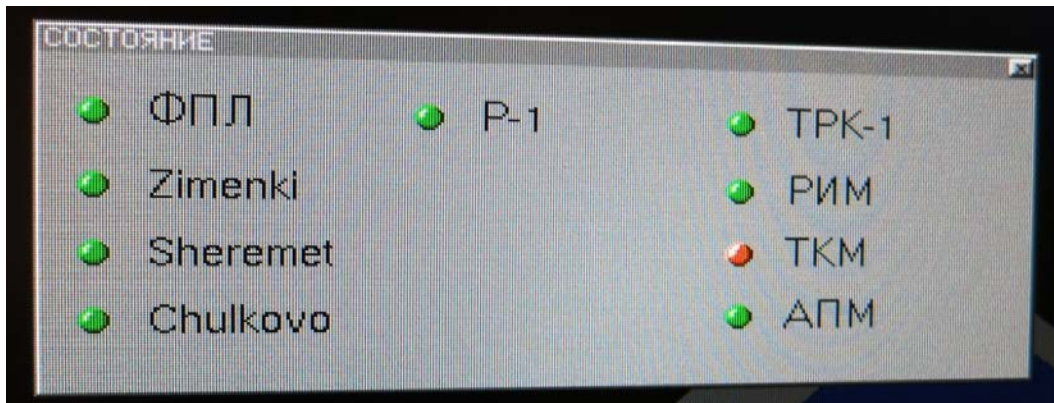

Figure 20. System Status Window at Supervisor WP

2. The activation of specific Reserved Lines is shown in Figure 21.

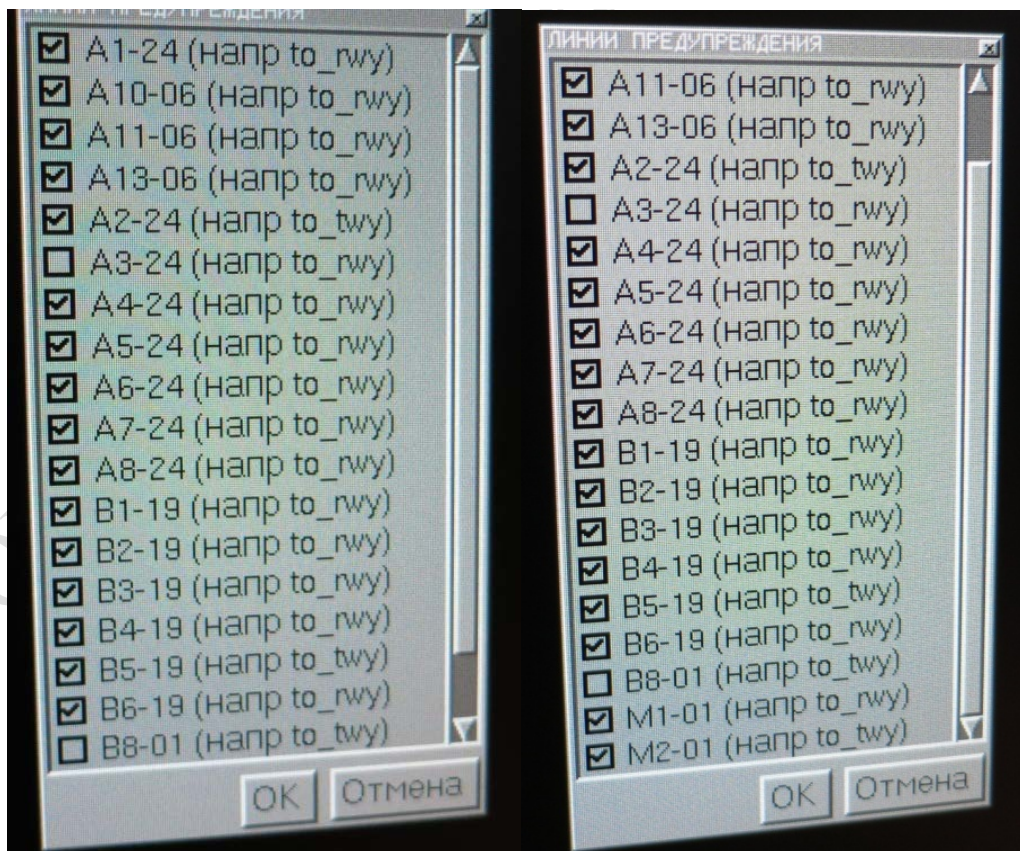

Figure 21. Reserved Lines at Supervisor WP (ticked lines are activated)

Not activated were the following reserved lines: A3-24 (To-RWY) and B8-01 (To-RWY).

3. The status of technical chart with Reserved Lines is shown in Figure 22. The chart is activated (ticked).



Figure 22. Technical chart status with Reserved Lines at Supervisor WP. The chart is activated (ticked)

4. Status of system technical charts is shown in Figure 23. Charts are activated.

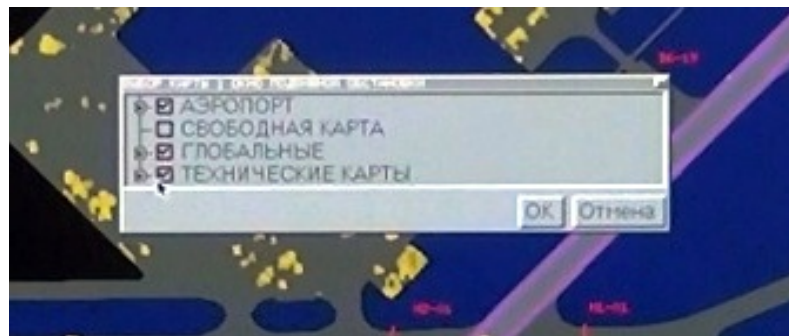

Figure 23. System technical charts status at Supervisor WP. Charts are activated (ticked)

5. The TRADIS indicator before the accident is shown in Figure 24.

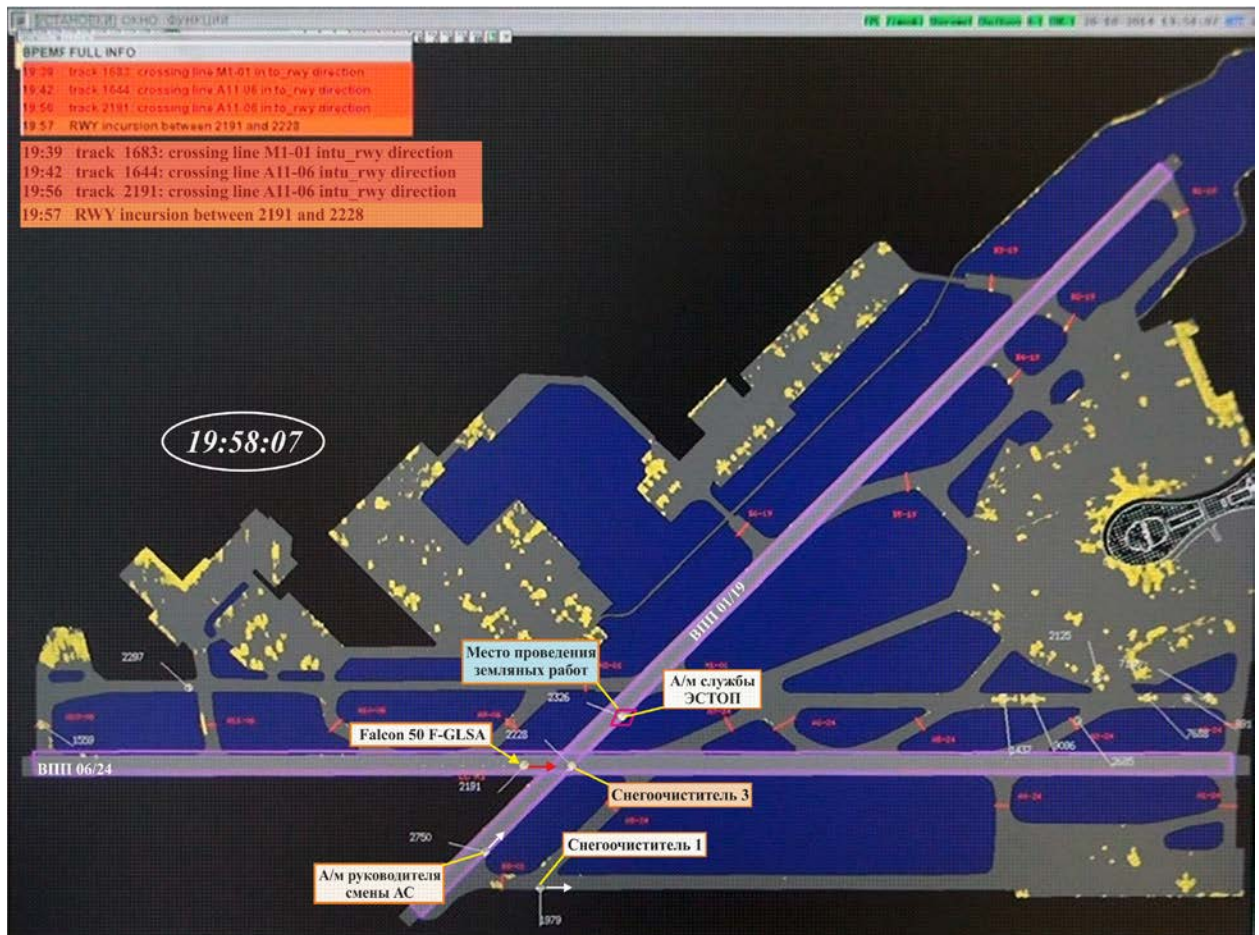

Figure 24. TRADIS indicator on supervisor's working position before the accident

The indicator shows alerts of Reserved Lines crossing:

- at 19:39 1683 crossed M1-01;
- at 19:42 1644 crossed A11-06;
- at 19:56 2191 crossed A11-06;

Alerts from the activated RIM:

- at 19:57 runway incursion between 2191 and 2228;

where:

- 1683 and 1644 are the number of tracks given by the system to other aircraft.
- 2191 is the number of track given by the system to the Falcon 50EX F-GLSA aircraft.
- 2228 is the number of track given by the system to snowplow 3, involved in the collision.

Thus the status of TRADIS at the supervisor's working position at the time of the accident was as follows:

- TCM alert monitoring off, RIM and APM alert monitoring on;
- all reserved lines directed towards the runway but two were activated;

- there were 3 alerts on TRADIS as reserved lines were crossed including the A11-06 reserved line crossed by the Falcon 50EX F-GLSA aircraft at 19:56 as it was taxiing to the line-up position. Neither of the alerts was confirmed (clicked) by the ATC shift supervisor.

- TRADIS shows a RIM alert: at 19:57 runway incursion between 2191 (the Falcon 50EX F GLSA aircraft) and 2228 (snowplow 3). This kind of alert is accompanied with a short-term aural alarm.

The table below summarizes the main information on the TRADIS working position configurations for Ground controller, Departure controller and ATC shift supervisor and their indications at the time of the accident.

	Ground	Departure	Supervisor
Alert monitoring TCM	Off	Off	Off
Alert monitoring RIM	Off	Off	On
Alert monitoring APM	Off	Off	On
Reserved lines towards runway total/on	20/9	20/20	20/18
Reserved lines technical chart	Not engaged	Engaged	Engaged
Alerts displayed at the time of the accident	5 (not confirmed)	5 (not confirmed)	4 (not confirmed)

1.9. Communication and Lighting

1.9.1. Basic Communication Aids

The Vnukovo airdrome is equipped with the following communication aids:

- radio stations (VHF);
- speakerphone;
- telephone and telegraph;
- internal airport communication. The VHF radio stations are located at the departure control. The main, standby and emergency transmitters are located at Postnikovo Transmitting Radio Center and Automatic Transceiving Radio Center of Vnukovo ATC Center.

The main radio reception is accomplished by receivers located at Filimonki Receiving Radio Center. The standby and emergency reception is provided by receivers of Automatic Transceiving Radio Center of Vnukovo ATC Center.

There is direct speakerphone communication between the control centers at the aerodrome. Besides there is direct speakerphone communication with A/Ds: Moscow (Sheremetyevo), Moscow (Domodedovo), Moscow ATC Center. Direct telephone communication with Kaluga and Ostaphyevo A/Ds. Telephone communication with the A/Ds in

Ramenskoye, Klin, Tula, Air Forces. Telegraph communication with Sheremetyevo, Domodedovo, communication with subscribers in Russia, CIS and Baltic countries.

There are also the following communication aids:

- VHF radio communication of aircrews to Flight Control and Coordination Centers at Vnukovo-1, Vnukovo-3, Transit-1 and Transit-2 ramps;
- speakerphone communication (direct communication) between all ATC points of Vnukovo airdrome, speakerphone communication between the airport production departments, technical services and airlines ensuring dispatch of aircraft, aircraft handling after landing as well as direct speakerphone communication with the Air Defense offices.
- automatic telephone communication providing access to city, intercity and international general telephone service;
- internal aerodrome radio communication at the airfield, at Vnukovo-1, Vnukovo-2 and Vnukovo-3, in air terminals, in the aerodrome terminal area and within Vnukovo A/D ATC handling area;
- meteorological information broadcast in VHF range;
- the search and rescue service is equipped with a mobile communication unit on a car with enhanced cross-country ability providing radio communication at search and rescue frequencies with aircraft and ATM, as well as all search and rescue units, also providing radiotelephony communication with access to the all-Russian telephone network of general use.

1.9.2. Standby Communication Aids

All communication and radio navigation aids used for ATM purposes at the aerodrome terminal area have standby equipment. A number of radio navigation aids provide automatic switching to standby equipment (on-course beacon, glide path beacon, localizer). The timing of switch to standby equipment is compatible with the landing category.

1.9.3. Communication Management During Airfield Operations

The communication management during airfield operations is determined in the Coordination Procedure of Aerodrome Service with Vnukovo ATC Center and other Ground Support Services at Vnukovo A/D brought into effect by Order № 162 of Director of Vnukovo Airport JSC as of 15.05.2014.

According to Instruction № 82 all aerodrome cars, tractors and vehicles working at the runways, taxiways, ramp and stands shall be equipped with internal airport communication radio stations, strobe and clearance lights as well as towing cables.

The aerodrome shift supervisor's car is additionally equipped with a radio receiver to listen to the radio exchange at the landing (departure) controller's frequency. The same

requirement is stated as well in the Airfield Service and Vnukovo Air Traffic Service Unit Interaction Procedures.

In accordance with FAR-362 Para 4.1 the rules of radiotelephony exchange shall be followed by all persons participating in ensuring flight operations support at the airdrome, organizing and supervising works on the airfield involving aerodrome cars and vehicles.

Persons conducting such works, as well as drivers of vehicles shall be constantly listening to the established internal airport communication frequency, and while working on the runways shall be constantly tuned to the radio exchange at the departure control frequency.

The investigation team notes that Instruction № 82 and the Airfield Service and Vnukovo Air Traffic Service Unit Interaction Procedures meet the FAR-362 requirements not to the fullest extent as for the vehicles that perform the works on the runway to be fitted with the equipment for continuous listening to the radio exchange at the departure controller's frequency. The snowplows are not fitted with such equipment.

The listening to the internal airport communication frequencies is conducted to receive additional instructions related to the order of the airfield traffic, information on aircraft and vehicles movement.

The radio exchange between the aerodrome service and the ATC shift supervisor (departure controller) of Vnukovo ATC Center is conducted via the internal airport radio communications at 163.5 MHz using Kenwood radio station.

The radio exchange between cars and vehicles of the aerodrome service and with the aerodrome director on duty is conducted via the internal airport radio communications at 163.8 MHz (at 163.5625 MHz if works are conducted at Vnukovo-3) using Kenwood radio station.

Radio communication with Ground Controller 1 of Vnukovo ATC Center via the internal radio communication at 163.7 MHz using Kenwood radio station and with Ground Controller 2 of Vnukovo ATC Center via the internal radio communication at 163,825 MHz using Kenwood radio station.

VHF radio exchange is conducted at 118.3 MHz (departure controller), 120.45 MHz (ground controller 1) and 121.7 MHz (ground controller 2).

Tuning to the internal airport radio communication frequencies is done to receive additional guidance on the airfield movements and traffic information.

For the radio exchange purposes the following callsigns are assigned to the various services and aerodrome vehicles:

- Aerodrome - aerodrome service dispatcher;
- First - departure controller;

- Third - ATC shift supervisor, landing controller;
- Fifth - ATC shift supervisor's car;
- Sixth - airfield service shift supervisor;
- Seventh - flight safety inspector engineer;
- Ground - ground controller;
- Shift Director - airport shift director on duty.

The aerodrome vehicles are assigned callsigns based by the names of services, organizations and garage numbers:

- Aerodrome No. - aerodrome service;
- Light No. - lighting service;
- Communications No. - communications service;
- Firefighting No. - fire fighting service;
- Security No. - airport security service;
- Medical No. - medical unit;
- Meteo No. - Roshydromet MAMC;
- Service Towing No. - Aircraft Service LTD;
- UTG Towing No. - UTG LTD;
- VARZ-400 Towing No. - VARZ-400 JSC;
- Follow-Me Ramp-1 No. - follow-me car of Vnukovo Airport JSC;
- Follow-Me Ramp-2 No. - follow-me car of Special Flight Squadron 'Russia';
- Follow-Me Ramp-3 No. - follow-me car of Business Aviation Center LTD;
- Radio No. - Radio Navigation Service of Vnukovo ATC Center.

All radio exchange of the ATC shift supervisor with persons in charge of airfield activities are recorded by tape recorders.

When drivers contact a controller of Vnukovo ATC Center via radio communication channels, they have to name themselves using the assigned callsign, state their location and route taken to the site of their activity.

In the controller is busy when contacted by a driver, the former is to inform the latter on the fact using the word: "Hold". This means that the driver is to wait for the controller to contact them and not start any movement until cleared to do so.

If it is impossible to provide clearance to the site requested by the driver, the controller of Vnukovo ATC Center can clear them to a different site after stopping whereat the driver is to request another clearance to proceed to the destination.

The ramp movement clearance can include all the necessary information concerning other traffic for safe ground traffic.

Under no circumstances is an aerodrome vehicle driver allowed to cross the runway until he received and confirms the applicable clearance. As soon as the runway is vacated the driver shall report it immediately.

A controller of the Vnukovo ATC Center provided clearance to a vehicle to cross a runway only in case an approaching aircraft has a sufficient time interval for the landing or after it has landed and overrun the place where the runway is to be crossed.

A clearance to cross a runway is to be requested after stopping before the beacon system critical area.

During airfield operation the airdrome service supervisor contacts the ATC controllers.

1.9.4. Runway Lights

Lighting at Moscow A/D (Vnukovo) is provided by the lighting service, which is a department of Vnukovo Airport JSC. Certificate of Compliance № FATA A.03.02802 was issued by FATA to Vnukovo Airport JSC on 21.05.2013. Valid till 21.05.2016.

Lighting equipment system Cat HIRL-III is installed on RWY 1. The flight check of the lighting system was accomplished within 19.09.2014 to 20.09.2014 by the crew of an An-26 aircraft laboratory operated by Flight Checks and Systems LTD. Certificate № 9 was issued by FATA. The certificate is valid from 02.12.2013 to 02.12.2016.

RWY 2, heading 013, is equipped with lighting equipment system CAT HIRL-I with centerline lights, heading 193 - with lighting equipment system CAT HIRL-II. The flight check of the lighting system was accomplished within 24.05.2014 to 25.05.2014 by the crew of an An-26 aircraft laboratory operated by Flight Checks and Systems LTD. Certificate № 10 was issued by FATA. The certificate is valid from 25.12.2013 to 09.09.2016.

Note: Certificates № 9 and 10.

Para 6. The certificate confirms compliance of the lighting system to the ANO-92 and ICAO Annex 14, Volume 1, Ed. 5, 2009.

1.9.5. Runway Lights on RWY 1 (06/24)

Lighting equipment Cat HIRL-III is installed on RWY 1, heading 238 degrees and 058 degrees.

The approach lights are white and spread for 900 m for heading 238 degrees magnetic and 900 m for heading 058 degrees magnetic, with a longitudinal interval of 30 ± 3 m for projector lights.

The bar lights are installed 150 m and 300 m from RWY 1 threshold 24 and 150 m and 300 m from RWY 1 threshold 06.

The projector lights UEL-1-150 with 150 W bulbs are installed on RWY 1 heading 238 degrees, just as heading 58 degrees.

As additional to the approach lights there are also FCU-3 impulse lights in the section of 900 to 300 m near each line light, making a total of 21.

Runway edge approach lights UEL-1-150 with 150 W bulbs are installed on RWY 1 heading 058 degrees and 238 degrees on the sector from 270 m to RWY threshold and consist of two rows of red lights.

White approach lights BPE-2-150 with 150 W bulbs and recessed FED-2-200 lights with 2 150 W bulbs each are located all along the runway as two parallel rows at a distance not further than 1.5 m from the runway edge, with an interval of 60 m. On the final 600 m of the distance the lights shine in yellow.

Green lead-in lights of the recessed type FTH-1-200 with one 105 W bulb each and recessed FTE-2-300 lights (lead-in limiting light) with two 105 W bulbs each are installed:

- heading 238 degrees magnetic - 1 m off the outer edge from threshold 24 making a total of 23 (evenly placed);

- heading 058 degrees magnetic - 1 m off the outer edge from threshold 06 making a total of 23 (evenly placed);

Red lead-in lights of the recessed type FTE-2-300 (lead-in limiting light) with two 105 W bulbs each are installed:

- heading 238 degrees magnetic - 1 m off the outer edge from threshold 24 making a total of 11 (evenly placed);

- heading 058 degrees magnetic - 1 m off the outer edge from threshold 06 making a total of 11 (evenly placed);

Centerline lights of the recessed type FRC-2-90 with two 48 W bulbs each are installed along the whole centerline with an interval of 15 m:

- red lights - from 300 m to the end of the runway;
- alternating in the two reds and two whites pattern - from 900-300 m till the end of the runway;

- white lights - on the remaining runway sector.

The shift of runway centerline lights from the runway centerline is 0.6 m.

The touchdown zone lights are white recessed FTZ-1-45 lights with 48 W bulbs are installed:

- heading 238 degrees magnetic - on the initial 960 m as two longitudinal rows of line lights. Longitudinal distance between the rows is 22.5 m. Each line light consists of three fixtures, with a distance of 1.5 m between them;

- heading 238 degrees magnetic - on the initial 960 m as two longitudinal rows of line lights, longitudinal distance between the rows is 22.5 m. Each line light consists of three fixtures, with a distance of 1.5 m between them;

Glide path PAPI lights PPL-400/3 with two 200-W bulb each are installed on the left side of the runway, 4 lights for each heading;

- heading 238 degrees magnetic - at a distance of 345.16 m behind threshold 24;

- heading 058 degrees magnetic - at a distance of 364 m behind threshold 06;

The closer light to the runway is located at a distance of 14 m from the runway edge with an interval between the lights of 8 m. Light line installation angle 0 degrees.

The glideslope angle is:

- heading 238 degrees magnetic - 3°00';

- heading 058 degrees magnetic - 3°00'.

The angle of light beam installation between the lights is 0°20'. The lights centerlines are parallel to the runway centerline.

Green taxiway centerline lights of the recessed type FTD-2-090 with two 48 W lights each are installed at TWY A1, TWY A2, TWY A3, TWY A4, TWY A5, TWY A6, TWY A7, TWY A8, TWY A9, TWY A10, TWY A11, TWY A12, TWY A13, TWY C1, TWY M1, TWY M2, TWY M3, RWY 1 sector from TWY A11 until crossing with RWY 2 along the centerline but no further than 0.3 m off the centerline to one side, with an interval of no more than 15 m, and no more than 7.5 m on a rounded sector.

Rapid exit taxiway indicator recessed lights FTD-2-090 with two 48 W bulbs are installed with an interval of no more than 15 m and no more than 7.5 m on rounded sectors:

- green towards the runway;

- alternating yellow and green from the runway.

The yellow rapid exit taxiway sign lights of the recessed type FTZ-1-45 with a 48 W bulb are installed before TWY A3, TWY A5, TWY A7, TWY A10.

Red stop recessed lights FTD-1-045 with 48 W bulbs are installed:

- on TWY A1, TWY A2, TWY A3, TWY A4, TWY A5, TWY A6, TWY A7, TWY A8, TWY A9, TWY A10, TWY A11, TWY A12, TWY M1, TWY M2, 6 lights on each.

- on RWY 1, before crossing with RWY 01/19 shining in the direction of heading 058 degrees, heading 238 degrees backtrack, 18 lights perpendicular to the runway and taxiway centerline with an interval of no more than 3 m between the lights.

Blue taxiway edge elevated lights VEE-3-030 with 30 W bulbs and recessed FTO-2-045 with 45 W bulbs are installed on TWYs M3, C2, C3, C8 at a distance of no more than 3 m from the taxiway edge with an interval of 60 m, shorter intervals on rounded sectors.

The following signs are installed at the airdrome:

- runway and location designations;
- location and direction;
- rapid exit taxiway;
- takeoff from the intersection.

Aerodrome signs are installed not closer than 12 m from the taxiway or runway edge, 30 m from the start of turn at taxiway intersections, 60 m from rapid exit taxiway signs. The holding point signage is constituted by signs denoting runways on both side of the taxiway.

1.9.6. Runway Lights on RWY 2 (01/19)

RWY 2, heading 193, is equipped with lighting equipment system CAT HIRL-II with centerline lights, heading 013 - with lighting equipment system CAT HIRL-I.

The approach lights are white and spread for 896 m for heading 193 degrees magnetic and 900 m for heading 013 degrees magnetic, with a longitudinal interval of 30 ± 3 m for projector lights.

The bar lights are installed 150 m and 300 m from RWY 2 threshold 19 and 150 m and 288 m from RWY 2 threshold 01.

Elevated UEL-1-150 lights with 150 W bulbs are installed on heading 193 and 013 degrees magnetic.

White elevated approach lights BPE-2-150 with 150 W bulbs and recessed FED-2-200 lights with two 150 W bulbs each are located all along the runway as two parallel rows at a distance not further than 1.5 m from the runway edge, with an interval of 60 m. On the final 600 m of the distance the lights shine in yellow.

Green lead-in lights of the recessed type FTH-1-200 with two 105 W bulb each and recessed FTE-2-300 lights (lead-in limiting light) with two 105 W bulbs each are installed:

- heading 193 degrees magnetic - 1 m off the outer edge from threshold 19 making a total of 17 (evenly placed);
- heading 013 degrees magnetic - 1 m off the outer edge from threshold 01 making a total of 18 (in two groups);

Red lead-in lights of the recessed type FTE-2-300 (lead-in limiting light) with two 5 W bulbs each are installed:

- heading 013 degrees magnetic - 1 m off the runway outer edge making a total of 9 (evenly placed);
- heading 193 degrees magnetic - 1 m off the runway outer edge making a total of 10 (in two groups);

Runway edge elevated approach lights UEL-1-150 with 150 W bulbs are installed on RWY 2 heading 19 on the sector from 270 m to threshold and consist of two rows of red lights.

Centerline lights of the recessed type FRC-2-90 with two 48 W bulbs each are installed along the whole centerline with an interval of 15 m:

- red lights - from 300 m to the end of the runway;
- alternating in the two reds and two whites pattern - from 900-300 m till the end of the runway;
- white lights - on the remaining runway sector.

The shift of runway centerline lights from the runway centerline is 0.6 m.

The touchdown zone lights are white recessed FTZ-1-45 lights with 48 W bulbs are installed on the initial 900 m heading 193 degrees as two longitudinal rows of line lights. Longitudinal distance between the rows is 22.5 m. Each line light consists of three fixtures, with a distance of 1.5 m between them;

Glide path PAPI lights PPL-400/3 with two 200 W bulb each are installed on the left side of the runway, 4 lights:

- heading 193 degrees magnetic - at a distance of 318.19 m behind threshold 19;
- heading 013 degrees magnetic - at a distance of 290.8 m behind threshold 01;

The closer light to the runway is located at a distance of 15 m from the runway edge with an interval between the lights of 9 m. Light line installation angle 0 degrees.

The glideslope angle is:

- heading 193 degrees - 3°00';
- heading 013 degrees - 3°00'.

The angle of light beam installation between the lights is 0°20'. The lights centerlines are parallel to the runway centerline.

Blue taxiway edge elevated lights VEE-3-030 with 30 W bulbs and recessed FTO-2-045 with 45 W bulbs are installed on TWYs B1, B2, B3, B4, B5, B6, B8, M1, M4 at a distance of no more than 1 m from the taxiway edge with an interval of 60 m, shorter intervals on rounded sectors.

Green taxiway centerline lights of the recessed type FTD-2-090 with two 48 W lights each are installed at TWY M1, along the centerline but no further than 0.3 m off the centerline to one side, with an interval of no more than 15 m, and no more than 7.5 m on a rounded sector.

Centerline rapid exit taxiway indicator recessed lights FTD-2-090 with two 48 W bulbs are installed with an interval of no more than 15 m and no more than 7.5 m on rounded sectors:

- green towards the runway;
- alternating yellow and green from the runway.

Red recessed stop lights FTD-1-045 with two 48 W bulb each are installed on TWY M1 shining backtrack, 8 lights perpendicular to the runway and taxiway centerline with an interval of no more than 3 m between the lights.

The following signs are installed at each taxiway:

- magnetic course;
- taxiway number;
- taxiing directions (arrows);
- runway distance.

Aerodrome signs are installed not closer than 12 m from the taxiway or runway edge, 30 m from taxiway intersections. The holding point signage is constituted by signs denoting runways on both side of the taxiway.

1.9.7. Runway Lights Switched on RWY 1 on 20.10.2014

The landing controller activated landing heading 058 degrees at 13:24, selected night time mode at 13:57 and visibility lower than 1 km at 17:20.

The following runway lights were switched on at the time of the accident (Figure 25):

- centerline approach lights, grade 4;
- edge approach lights, grade 4;
- lead-in lights, grade 4;
- runway centerline lights, grade 4;
- runway edge lights, grade 4;
- touchdown zone lights, grade 3;
- glide path lights, grade 5;
- sequenced flashing lights, grade 2;
- aerodrome signs, grade 5;
- taxiway centerline lights, TWYs A2-A11, A13, C2-C6, M2, M3, grade 5;
- stopline lights, TWYs A2, A3, A5-A11, A13, grade 5;
- rapid exit taxiway indicator lights, grade 5;

Brightness grades in accordance with the AON-92 are shown in the table:

Light brightness grades	Light intensity increment, %
1	1
2	3
3	10
4	30
5	100

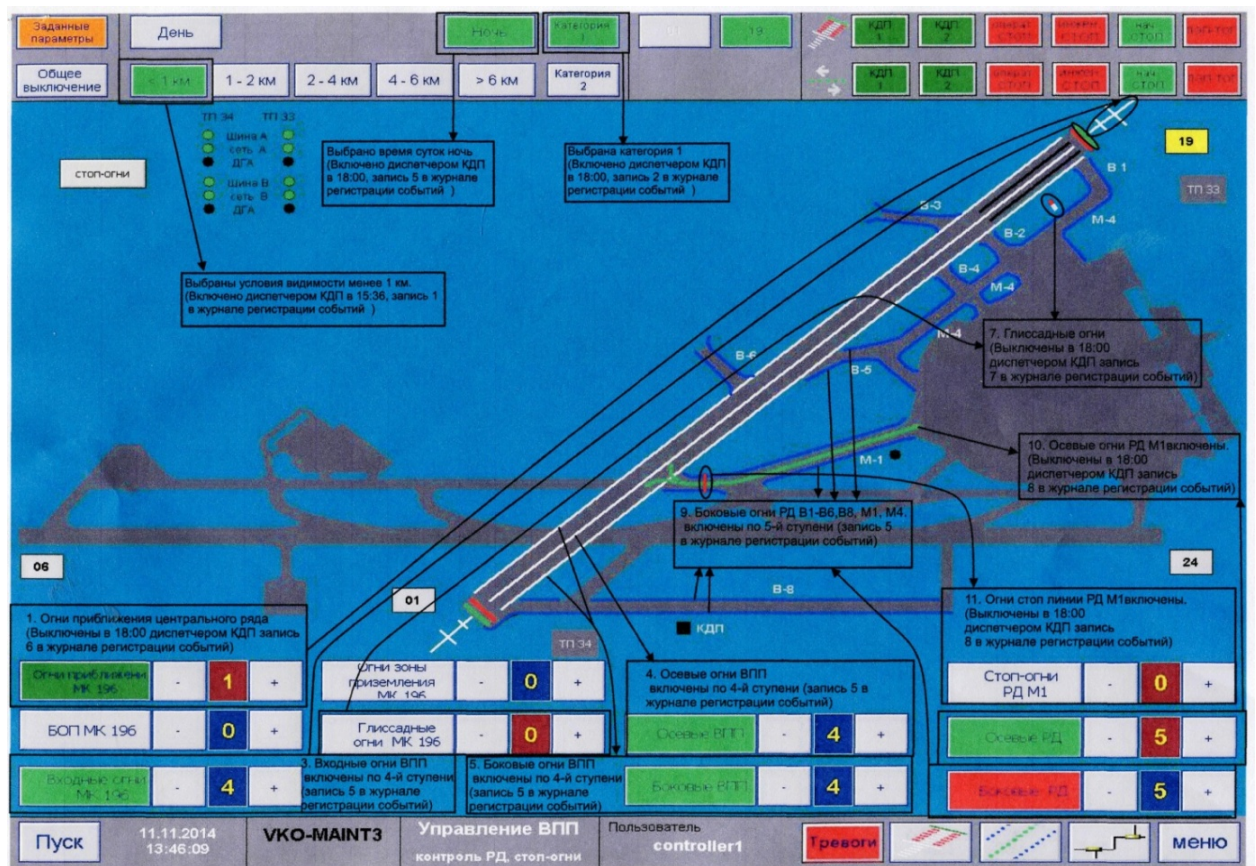

Figure 25. Runway lights, heading 058 degrees at Moscow A/D (Vnukovo) during the accident on 20.10.2014

1.9.8. Runway Lights Switched on RWY 2 on 20.10.2014

The landing controller activated selected CAT I, night time mode at 14:00 and visibility lower than 1 km at 11:36.

The following runway lights were switched on at the time of the accident (Figure 26):

- centerline approach lights, activated at 14:00;
- lead-in lights, grade 4;
- runway centerline lights, grade 4;
- runway edge lights, grade 4;
- taxiway centerline lights, TWYs B1-B6, B8, M1, M4, grade 5;
- taxiway centerline lights, TWY M1, activated at 14:00;
- taxiway stopline lights, TWY M1, activated at 14:00.

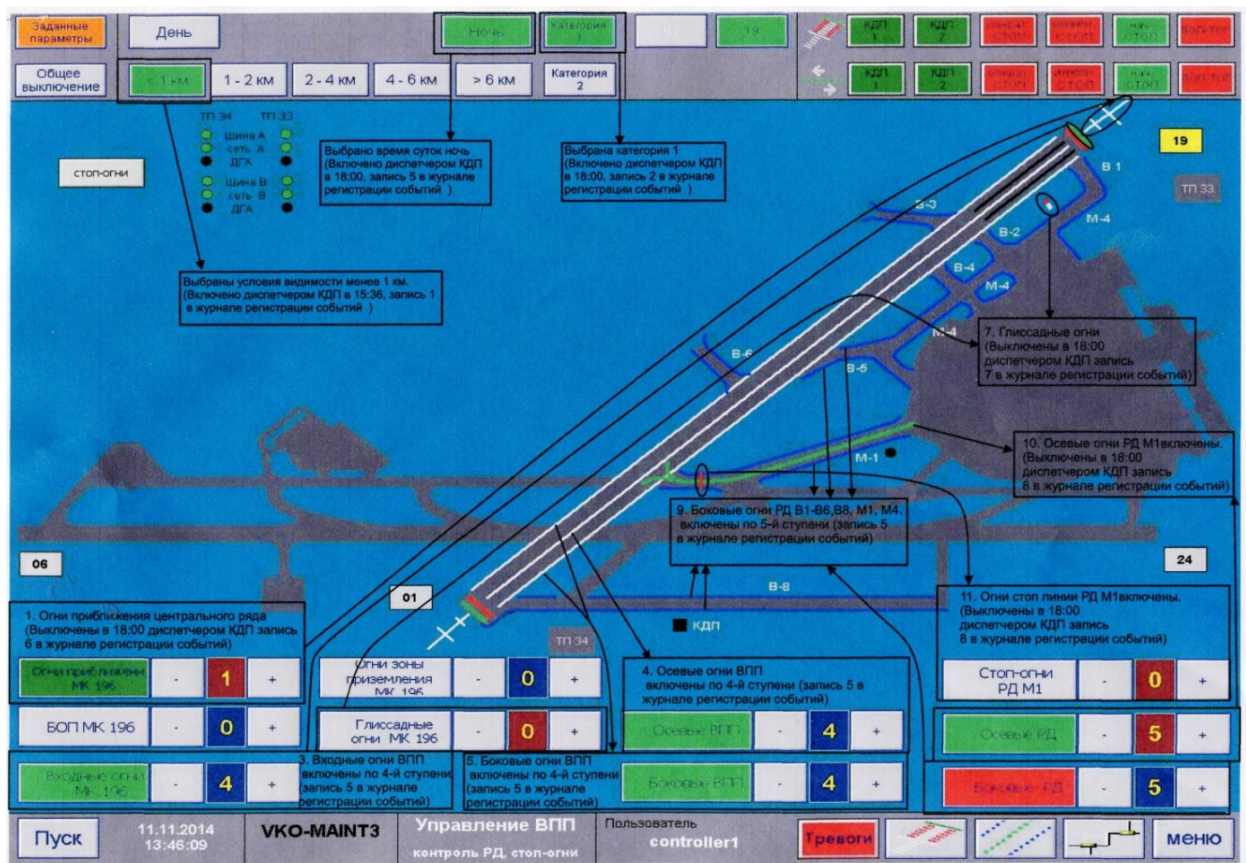

Figure 26. Runway lights, heading 193 degrees at Moscow A/D (Vnukovo) during the accident on 20.10.2014

1.10. Airdrome Information

The Moscow airdrome (Vnukovo) is a joint base Class B civil aviation airdrome (ICAO Class 4E). It is federal property of the State and ran by Civil Aviation Airports (Airdromes) Authority Federal Unitary Enterprise.

Working hours - 24/7.

In accordance with the Airdrome State Registration and Operational Certificate № 10 as of 25.01.1995 (extended till 07.07.2016) the airdrome is suitable for aircraft arrivals and departures at day and night time, all year round.

According to Certificate № 015A-M issued by Airdrome and Equipment Certification Commission, IAC as of 02.12.2013 (valid till 15.01.2015) the airdrome complies with certification requirements of AON-92.

The airdrome is suitable for international flights.

Airdrome location index: Moscow (Vnukovo) – YYBB/UUWW (Russian federation/ICAO), IATA code – BHK/VKO.

In accordance with Decision № AH 1.04-1269 of the Head of FATA as of 24.04.2012, the General Director of Vnukovo Airport JSC was appointed as the Chief Aviation Head of the Joint Base Civil Airdrome Moscow (Vnukovo).

The applied coordinate system is PZ-90.02.

The Vnukovo airdrome is located 27.8 km to the south-west of the center of Moscow and 5.6 km to the south of Vnukovo railway station.

ARP altitude is +205.69 m, airdrome elevation is +208.75 m, magnetic declination is +10°14'. ARP geographical coordinates are: N 055°35'56.7", E 037°16'22.7".

The airfield is triangular measuring 4800×2700 m. The airfield surface is plane, with soft ground, loam soil with grass, not suitable for takeoff or landing.

The airdrome has two intersecting runways with artificial pavement. (Figure 27 and Figure 28):

- airstrip 1 (3800×300 m). RWY 1 (06/24), Class B, 3500 m long, usable width 60 m along the whole runway. Pavement - concrete.

- airstrip 2 (3360×300 m). RWY 2 (01/19), Class B, 3060 m long, usable width 45 m along the whole runway. Pavement - asphalt concrete.

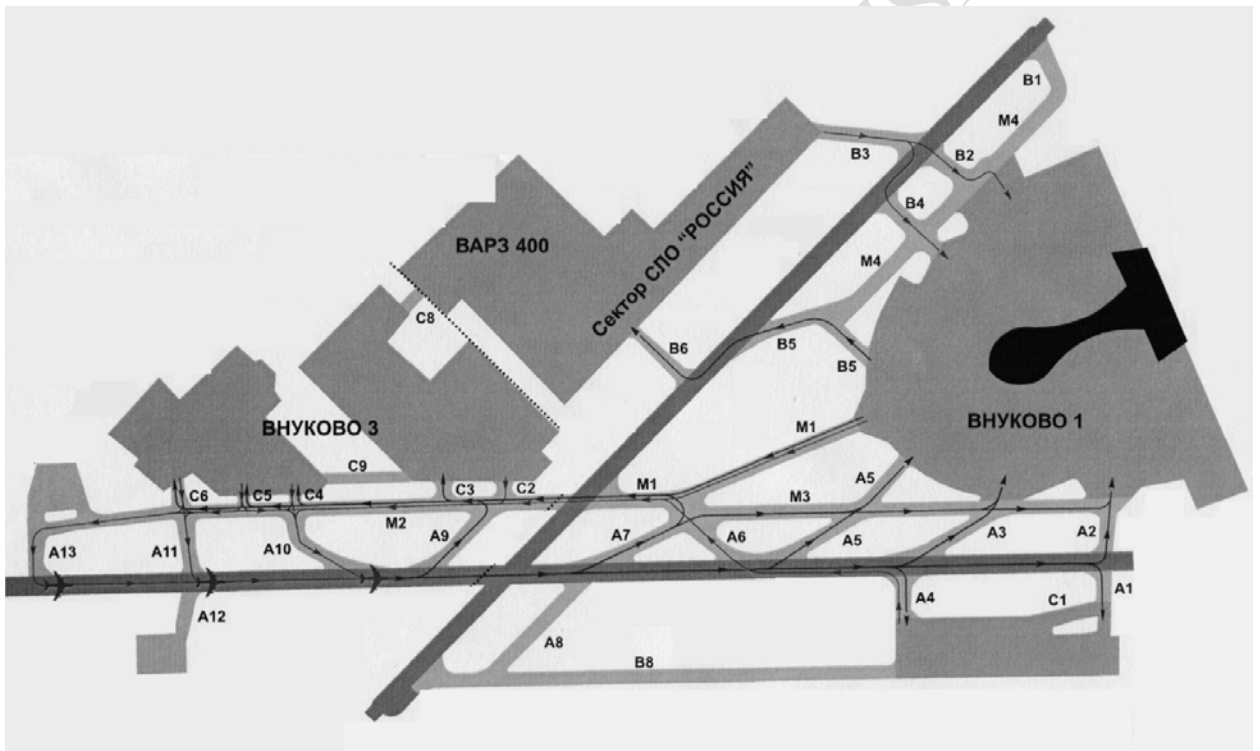

Figure 27. RWY 1, RWY 2 and TWY location at Vnukovo Airdrome

АЭРОДРОМ

UJWW

27 июн 13

Д-1

АТИС	125.875	рус	131.850	анг
ВНУКОВО Старт	118.300		119.450	резв
ВНУКОВО Руление 1 ①	120.450		119.450	резв
ВНУКОВО Руление 2 ②	121.700		119.450	резв
ВНУКОВО Транзит	131.875			
ВНУКОВО ВИППОРТ	122.875			
ВНУКОВО Delivery ③	131.800			
ВНУКОВО Delivery ④	131.125			
ВНУКОВО Service	118.900		118.800	резв
ВНУКОВО UTG	123.250			

МОСКВА, РОССИЯ

КТА: ВНУКОВО
N55 35 57 E037 16 23
Наэр. 208.8 685'

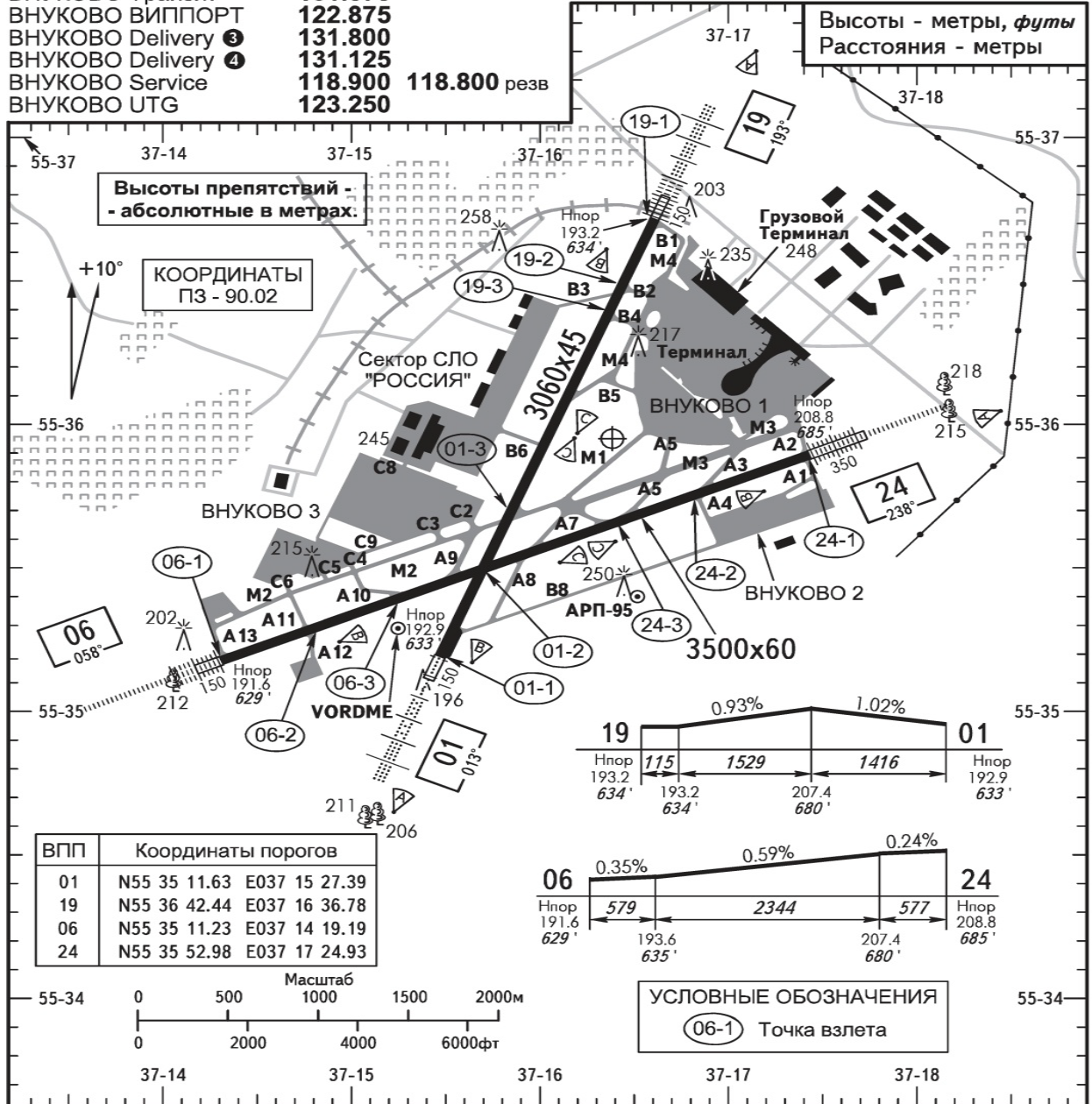

МИНИМУМЫ ДЛЯ ВЗЛЕТА

Кат. ВС	ВПП 01/19				ВПП 06/24			
	Н н.г.о.	С огнями оси ВПП	Без огней день	оси ВПП ночь	Н н.г.о.	С огнями оси ВПП	Без огней день	оси ВПП ночь
A				300				300
B		200	300			200	300	
C				400				400
D								

- ① ВНУКОВО Руление 1: Перрон ВНУКОВО 1, ВНУКОВО 2, СЛО "РОССИЯ", ВАРЗ-400, зона маневрирования аэродрома исключая зону ответственности РУЛЕНИЕ 2.
- ② ВНУКОВО Руление 2: Перрон ВНУКОВО 3, РД М2, А9-А13, участок ВПП 06/24 от торца ВПП 06 до пересечения с ВПП 01/19.
- ③ На перронах ВНУКОВО 1 и ВНУКОВО 2.
- ④ Вне перронов ВНУКОВО 1 и ВНУКОВО 2.

Figure 28. Vnukovo A/D map

Within 60 m to either side of the RWY 1 and RWY 2 centerlines there are no obstacles. The ground surface of the graded airstrips of RWY 1 and RWY 2 areas adjacent to the artificial pavement is the same level as the latter.

True track angle of RWY 1 (06/24) is $068^{\circ}19'48''/248^{\circ}22'21''$.

The RWY 06/24 thresholds coincide with the start of the runway.

RWY 06/24 bearing capacity is PCN 72/R/B/W/T.

Longitudinal central runway slope is + 0.005883.

Longitudinal edge runway slope is:

- heading 058 degrees: +0.003484;

- heading 238 degrees: +0.002401.

Average longitudinal runway slope is +0.004912. Lateral runway slope at any part of the runway is 0.0012.

Airstrip 1 (3800×300 m) is extended laterally 150 m to both sides of the runway centerline along the whole length of the runway.

The airstrip graded part extends 80 m to both sides of the runway centerline.

The airstrip extends 150 m after the end of the runway heading 24 and 06.

The reinforced part of the airstrip measures:

- RWY 24: internal width 60 m, external width 60 m, length 75 m;

- RWY 06: internal width 60 m, external width 60 m, length 75 m.

Within the graded airstrips of RWY 1 and RWY 2 there are no objects except those functionally needed.

There are no clearways at the end of runways.

Instruction on Flight Operations in Vnukovo A/D Terminal Area was approved by General Director of Vnukovo Airport JSC as of 29.07.2011. It was registered at FATA Central Regional Office, registration № И41-137 as of 18.08.2011.

It shall be noted that the following is written in the Instruction:

- Section II, Para 2.6 "Aerodrome Minima" states that the airdrome is authorized to accept aircraft in accordance with the following minima: ICAO CAT III A - RWY 06 and 24, CAT II - RWY 06, 24 and 19, and CAT I - RWY 06, 24, 19, 01;

- Section IV, Para 4.2.5 "Limited Visibility Procedures, CAT II and CAT IIIA", Para 4.2.5.1 "General" states that RWY 06 and RWY 24 are equipped for CAT II and CAT IIIA precision approaches, and RWY 19 is equipped for CAT II precision approaches.

The information concerning the capability of accepting aircraft for CAT IIIA approaches had been included into the Instruction to hasten the aircraft to be open for CAT III approaches after it accomplished all the aerodrome preparation procedures required for such approaches.

Before all CAT III A authorization procedures were accomplished, NOTAMs A4914/13 and B6448/13 (for 20.10.2014, NOTAMs A3247/14, B4169/14) were issued that prohibit CAT III approaches.

Note:

NOTAMs:

(A3247/14 NOTAMR A0842/14

A)UUWW B)1408270600 C)1501312000

E) RWY 06/24 ILS DME: CAT IIIA APPROACHES NOT PROVIDED.)

(B 4169/14 NOTAMR B1185/14

A)UUWW B)1408270605 C)1501312000

E) RWY 06/24 ILS DME: CAT III APPROACHES NOT PROVIDED.)

1.11. Flight Recorders

1.11.1. Flight Data Recorder

The Falcon 50EX F-GLSA was equipped with a Honeywell SSFDR 980-4710-003 flight data recorder.

The FDR casing revealed no signs of mechanical or thermal damage. The FDR data readout was conducted at IAC laboratory in cooperation with a BEA Technical Department expert using the Honeywell RPGSE readout equipment. During the readout approximately 26 hours and 52 minutes of flight data was downloaded. The record contained data of 4 flights and the accident takeoff of the Falcon 50EX F-GLSA aircraft at Vnukovo A/D.

The readout data processing and analysis were accomplished with use of the WinArm32 software.

The following was found as a result:

- The Honeywell SSFDR 980-4710-003 FDR was operative and had recorded data on 4 flights and the accident takeoff on 20.10.2014 at Vnukovo airdrome from the time it was switched on at 16:02 till the aircraft hit the ground at 19:58:13. The data were recorded in compliance with the established list of parameters and on/off signals for the aircraft type;
- no on/off signals or parameters were recorded that would denote malfunction or failure of any aircraft system or equipment during the takeoff on 20.10.2014 at Moscow (Vnukovo) airdrome until the collision.

The readout plots for the Falcon 50EX F-GLSA aircraft takeoff on 20.10.2014 at Moscow (Vnukovo) airdrome are shown below (Figure 62, Figure 74, Figure 77, Figure 78).

1.11.2. Cockpit Voice Recorder

The Falcon-50EX F-GLSA aircraft was equipped with a Honeywell SSCVR 980-6022-011 cockpit voice recorder.

The CVR casing revealed no signs of mechanical or thermal damage. The CVR data readout was conducted at IAC laboratory in cooperation with a BEA Technical Department expert using the Honeywell RPGSE readout equipment.

The readout data analysis revealed that the readout copy had records in 5 channels:

- Channel 1 - voice record from the flight attendant's working station, duration 30 minutes 21 sec, frequency 8000 Hz;
- Channel 2 - voice record from the FO's working station, duration 30 minutes 21 sec, frequency 8000 Hz;
- Channel 3 - voice record from the PIC's working station, duration 30 minutes 21 sec, frequency 8000 Hz;
- Channel 4 - voice record from the cockpit recorder, duration 2 hours, 1 minute and 8 seconds, frequency 16000 Hz;
- Channel 5 - mixture voice record from Channels 1, 2 and 3, duration 2 hours 4 minutes 56 seconds, frequency 8000 Hz.

As the voice information was processed it was determined that the record contained the crew verbal exchange while they were preparing for and conducting takeoff on 20.10.2014 at Vnukovo airport until the crash.

1.11.3. CVR and FDR Data Synchronization

For the synchronization purposes the UTC time recorded by the Moscow (Vnukovo ATC) operational recorder was selected as the reference time base.

As the CVR does not record time, the synchronization of the flight and voice data was conducted by means of comparing the FDR mike on/off signals with the time marks limiting the time span of the pronounced phrases from the CVR record. The synchronization of the FDR and CVR data was accomplished with tolerance of no more than 0.2 seconds.

The next stage was synchronization of CVR data with the ATC tape recorder data that contained time record settings in such a way that the tolerance would not exceed 1 second.

The airfield surveillance and control subsystem A3000 time was the same as the ATC recorder time. The display is upgraded every second.

1.11.4. Flight Path Calculation

The Falcon 50EX F-GLSA aircraft path calculation was conducted for its entire movement track from stand 24 until its collision with the snowplow at the crossing of RWY 1 and RWY 2.

The calculation made use of the data from Honeywell SSFDR 980-4710-003 FDR and the airfield surveillance and control subsystem A3000.

The calculation was done using the WinArm32 software.

The path parameters are plotted in Figure 63.

1.12. Wreckage Information

The aircraft collided with the snowplow 3 SUPRA 5001, garage number 377 at the crossing of RWY 1 and RWY 2 at a point with the following coordinates: N 55°35'29.66", E 37°15'41.12" (Figure 29).



Figure 29. Crossing of RWY 1 and RWY 2 (marked by arrow) (picture taken along RWY 24)

The wreckage plot is shown in Figure 30 and Figure 31.

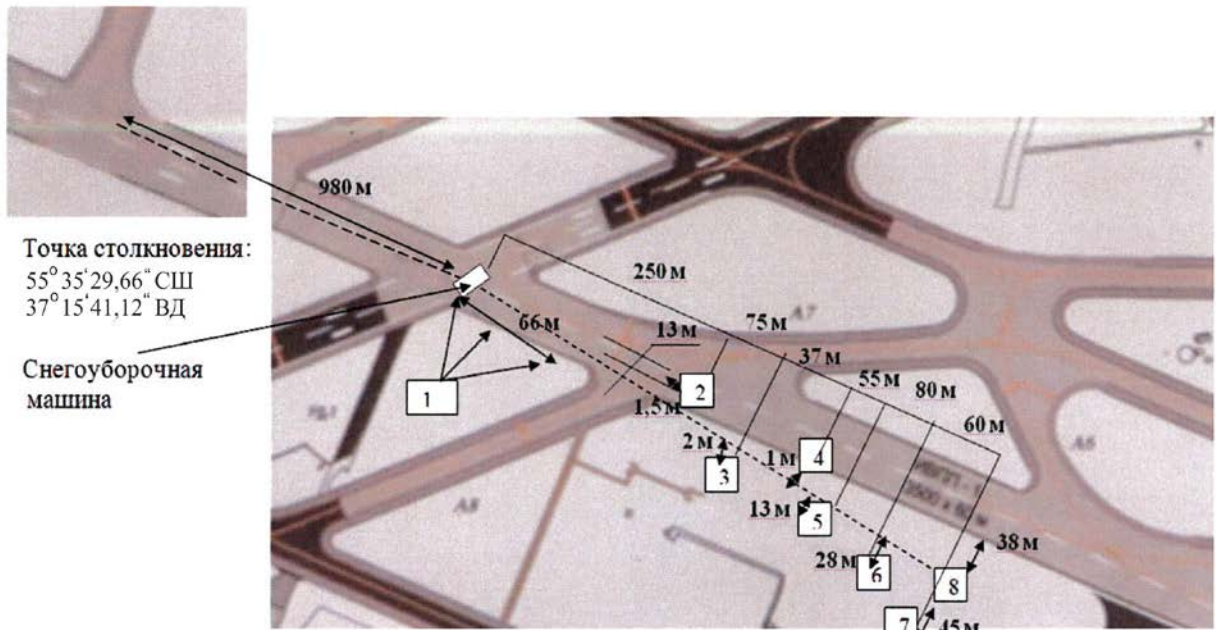

Figure 30. Wreckage plot



Figure 31. Accident Wreckage Plot

1. Main aircraft fragments location 2. Aft part of engine cowling 3. Engine No.1. 4. Left wing with main landing gear. 5. Radome. 6. Engine № 3. 7. Upper part of fin. 8. Middle part of fin.

As a result of the ground impact the aircraft sustained substantial damage to airframe and systems. The fragments were spread over an area measuring 560 m by 60 m.

1.12.1. Aircraft Condition

An external inspection of the aircraft fragments, its systems, engines and avionics was conducted at the accident site.

The inspection revealed the following.

The aircraft was lying inverted on the ground in the RWY 1 takeoff direction, destroyed. The largest fragment of the aircraft (fuselage with right wing) was on the ground near RWY 1 38 m from the right edge of RWY 06 and 557 m from the crossing of RWY 1 and RWY 2.

As a result of the collision with the snowplow and further the ground impact the aircraft was destroyed into the following elements:

- radome;
- fuselage and RH wing with a fragment of RH main landing gear;
- LH engine;
- LH wing with left main landing gear.
- fragment of fin with stabilizer;
- upper part of fin.
- RH engine;
- fragment of RH main landing gear;
- small fragments of airframe and engine panels, aircraft equipment were spread chaotically along the flight path within a 60 m wide strip from the fragment of the right main landing gear to the largest airframe fragment.

Radome

Inverted (Figure 32), deformed in the lower part, skin and rib fractured on the right side. A part of the rib at the attachment of the radome turning mechanism was missing. All radar units were secured as per design and had no external damage. All visible socket connectors were connected to the respective units.



Figure 32. Radome.

Fuselage and right wing

Fuselage and right wing with a fragment of right main landing gear was found inverted (Figure 33) and broken into two parts along the rib behind the door. The rivets were torn up on ground impact. A geometric fracture in the middle part of the fuselage had appeared due to the skin being burnt out and ribs and stringers being damaged by high temperature during the fire. The high temperature impact at that place was confirmed by round flattened solidified drops of melted metal up to 15 mm in diameter. The right wing tip was touching the ground. The junctions of central wing to the left wing were destroyed.



Figure 33. Fuselage and right wing

The hinged arm of the radome opening mechanism with a radome rib fragment was turned to the right along the takeoff direction (open). The radar units fitting frame was deformed, wiring and ducts torn, no signs of fire.

The nose landing gear was extended, showing no mechanical damage or fire traces (Figure 34).



Figure 34. Nose landing gear

The cockpit glassing and upper part of the fuselage up to the center wing were destroyed. The fuselage from the front entry door to the baggage hatch was significantly damaged affected by high temperature. The left side of the fuselage and passenger compartment was almost completely destroyed by the fire.

The air intake of Engine № 2 was sheared by the ground impact, destroyed and pressed into the fuselage.

The fin with stabilizer was torn off resulting from lateral ground impact.

The tail part of the fuselage had paint damage due to the high temperature, cowlings of Engine № 2 were latched, the baggage compartment hatch was open, the aft technical compartment hatch was latched. There were no signs of fire in the baggage compartment, technical compartment or engine bay. Aircraft system units in these compartments did not have any mechanical damage.

The fittings of Engine № 1 and Engine № 3 were damaged, wirings and ducts torn out (Figure 35 and Figure 36).



Figure 35. Engine № 1 Fitting



Figure 36. Engine № 3 Fitting

Cockpit

The cockpit was deformed; instrument panel indicators had signs of soot, control wheels synchronically turned to roll left. The throttle levers were set to takeoff position, thrust reverse lever of Engine № .2 retracted, flap/slat control handle set to S+FLAPS 20°, landing gear control switch set to LG DOWN (Figure 37).



Figure 37. Cockpit

The PIC seat attachment was destroyed; the FO seat did not have any mechanical damage. The right aft wall of the cockpit was missing.

The circuit breaker panel from the right aft cockpit wall was damaged. Due to the actions conducted by the emergency services during the rescue operations it was impossible to determine the position of the circuit breakers at the moment of the accident. The central control panel had

traces of soot, with no mechanical damage. The left control panel was missing (destroyed during the rescue operations), the RH control panel did not sustain any mechanical damage. The upper power panel was destroyed due to cockpit ceiling deformation by ground impact.

Center wing section

The center wing had traces of fire and deformation, lower panels burnt out (Figure 38). The LH wing to center wing attachment was destroyed along the wing rib, the center wing fuel tank was torn open, fuel missing.



Figure 38. Fuselage and LH wing attachment

RH wing

The RH wing showed damage, skin deformation and fire traces. There was a hollow metal foreign fragment in the form of a flattened squared tube (a snowplow fragment) pressed in between the outer and inner slat sections (Figure 39). The metal fragment was wedged perpendicular in the center between the right and left leading edge slat of the right hand wing. The lower part of the RH wing had a through zig-zag crack extending from the forward spar to the aft spar.



Figure 39. RH wing with a snowplow fragment

The RH outer flap was split into two parts almost in the middle (Figure 40), its outer part extended (downward), and inner part bent upwards. The RH aileron was deflected to the utmost right roll, and could be moved freely with a hand. The RH wing tip was destroyed, the navigation lights cone broken. The RH slat was torn into two parts by a foreign object, its outer part extended, its inner part destroyed and hanging on the slat cranks.



Figure 40. RH wing

The RH main landing gear fitting was destroyed, the strut cylinder bent backwards, the shock strut piston with wheels was ripped off and lying on RWY 1. The landing gear bay door was open, with rods separated.

LH wing

The LH wing with left main landing gear (Figure 41) was detached from the center wing along the wing rib, screw fittings being torn. The root part of the LH wing and the LH aileron tip preserved their design dimensions. The middle part of the LH wing was destroyed by fire after the crash. The LH main landing gear was extended, showing no mechanical damage. The remaining fragments of slat and flaps sections were extended.



Figure 41. LH wing with LH main landing gear

Fin with stabilizer

The fragment of fin with horizontal stabilizer (Figure 42) was found perpendicular to the aircraft path after the collision. The attachment of fin to the fuselage sustained tear damage. The upper part of fin was missing; the lower part had substantial damage: the fin fairing and rudder were missing, the fin skin torn.



Figure 42. Fragment of fin with horizontal stabilizer

All structural damage to the airframe was the result of the loads beyond ultimate design that were caused by the collision of its right main landing gear and right wing leading edge with the snowplow, followed by ground hit and fire.

Aircraft Control

The ailerons, rudder and elevator control cables (located under the floor panels from the control panels to the cockpit aft wall) were not damaged. Part of the cables under the cabin floor was totally destroyed and burnt by the fire. The control wheels were turned synchronically to left roll.

Flaps Control

The position of slats and flaps on the remaining part of the wing as well as flap and slat driving rods means the flaps and slats position was compatible with the position of the control handle on the central control panel, set to S+FLAPS 20° (slats and flaps 20 degrees).



Figure 43. Flaps actuator jack screw

Examination of the control system wreckage confirmed that there were no typical metal fractures that would signify fatigue failure. All control system damage had traces of bending deformation. All damage of control system occurred due to overload and post-crash fire.

Fuel System

Center Wing Tank

The center wing fuel tank was torn open and damaged. The fuel leaked out completely after the aircraft hit the snowplow and the LH wing was separated from the center wing.

RH Tank

The RH fuel tank was torn open, having a lateral zig-zag crack (Figure 44). The fuel leaked out completely after the wing hit the snowplow.



Figure 44. RH fuel tank

LH Fuel Tank

The LH fuel tank was torn open, 50% of the tank structure (from the LH landing gear to the LH aileron) was destroyed by the fire (Figure 45). The fuel leaked out completely after the LH wing was detached from the center wing.



Figure 45. LH fuel tank

The fuel ducts leading to Engines № 1 and 3 were torn and deformed. The fuel ducts leading to Engines № 2 were not damaged.

As there was no fuel left in the fuel tanks the investigation team had to take fuel samples from the engine fuel filters for examination.

The engines operability until their deactivation, the inspection of units and assemblies at the accident site as well as the flight data readout allow assuming the fuel system was operative before the accident. The fuel amount on board was sufficient for the flight.

All damage to the fuel system elements was caused by overload due to the aircraft collision with the snowplow, followed by ground hit and post-crash fire.

Landing Gear

As a result of the aircraft collision with the snowplow the shock strut piston of the RH landing gear with wheels was torn off the landing gear structure and remained at the area of collision (Figure 46).

The wheel tire had lateral tear, a crack induced by the hit on the wheel disk rim collar, the upper link of the hinge was destroyed. A fragment of the RH main landing gear with the strut cylinder and cross brace was bent backwards (comparing to the flight direction).



Figure 46. RH main landing gear

The nose landing gear was extended on the nose fragment, showing no mechanical damage. The fittings were undamaged, the hinge attached. The screws were tightened. The inshot valve nozzles were closed.

The LH landing gear was extended on the LH wing fragment, showing no mechanical damage. The fittings were undamaged. The screws were tightened. The inshot valve nozzles were closed. The hinge was not destroyed. The landing gear structure had traces of fire.

All damage to the landing gear was caused by loads beyond ultimate design due to the aircraft collision with the snowplow.

Electrical Power

Four direct current generators (one on each engine and on the APU) were installed as per design without any visual damage. The power wiring clamps were tightened.

Radio Equipment

The VHF radio stations were operative within the entire flight, which is confirmed by the stable radio communication of the crew with the ATC. The operability of the radio equipment is confirmed by the readout of the radio exchange record between the crew and ATC as well as absence of complaints on the operation of the radio equipment from the crew.

Anti-Ice System

The heated windows on both sides were broken as the aircraft hit the ground. The RH pitot tube is bent, neither the LH pitot tube or the angle of attack gauge was damaged.

Electrical Equipment

The electrical equipment was operative within the entire flight until the aircraft hit the ground and ensured functioning of all electrical supply consumers in compliance with the technical requirements, which is confirmed by the FDR readout.

Aircraft Lights

The nose gear light was not damaged, the filament was not damaged either. The lights in the forward part of the center wing fairing were destroyed by the fire.

Flight Instruments

The LH and RH pilot control panels sustained mechanical and thermal damage.

LH control panel: indicator screens damaged by the fire. Flight controls position indicator: aileron symbol was in the extreme position - left aileron up, right aileron down at 50 degrees (provided the control wheels were synchronically turned to left roll). Rudder indicator was 40 degrees left.

LH control panel: indicator screens damaged mechanically and by the fire.

Central control panel: indicator screens damaged mechanically. The landing gear protraction/retraction tab was set to DOWN. The LG emergency extension tab is stowed and locked.

The overhead control panel sustained mechanical damage as the aircraft hit the ground. The circuit breakers' position could have been changed due to rescue units activities.

The left and right bus bar switch was set to SEPARATE. Direct current voltmeters and amperemeters sustained mechanical damage. Generators and batteries switches position:

GEN1 – on; GEN 2 – off; GEN 3 – on; BAT1 – on; BAT2 – on;

Parameter measurement selector switches position:

- LH side - BAT1;

- RH side - GEN2.

The flight instruments were operative within the entire flight, which is confirmed by the FDR record of roll and pitch parameters.

Based on the analysis of the operational and maintenance documentation, witness observations, aircraft systems, engine and fuel system operability analysis, the investigation team revealed the following:

1. Within the accident flight the Falcon 50EX F-GLSA aircraft the engines and equipment were operative until the moment it collided with the snowplow.

2. No signs of possible failures during the accident flight were revealed.
3. The aircraft structures were damaged or destroyed as a result of loads beyond ultimate design as the aircraft hit the snowplow and the ground as well as the fire.

1.12.2. Damage to Snowplow

The condition of the snowplow after the accident is shown in Figure 46a. Upon collision with the aircraft the snowplow sustained the following damage:

- the windshield and forward window on the left door were cracked;
 - the snow evacuation nozzle was separated by collision with the RH wing;
 - the engine cowling was opened backwards and damaged;
 - the forward part of the cab roof was damaged: part of the roof was torn upwards making a hole into the cab;
 - the far-reaching headlights were damaged: glass broken, right light was ripped off its attachment and missing;
 - dipped headlights were damaged: left light glass broken, the light bulb was missing, the right light reflector with attachment frame was missing;
 - the glass and bulbs of the right forward clearance light were missing, the casing being damaged;
 - the roof strobe light glass was missing;
 - the engine cowling strobe light was missing;
 - the left reverse movement light's casing was damaged;
- the engine cowling contained a dent on the RH side left by the airplane landing gear tire.

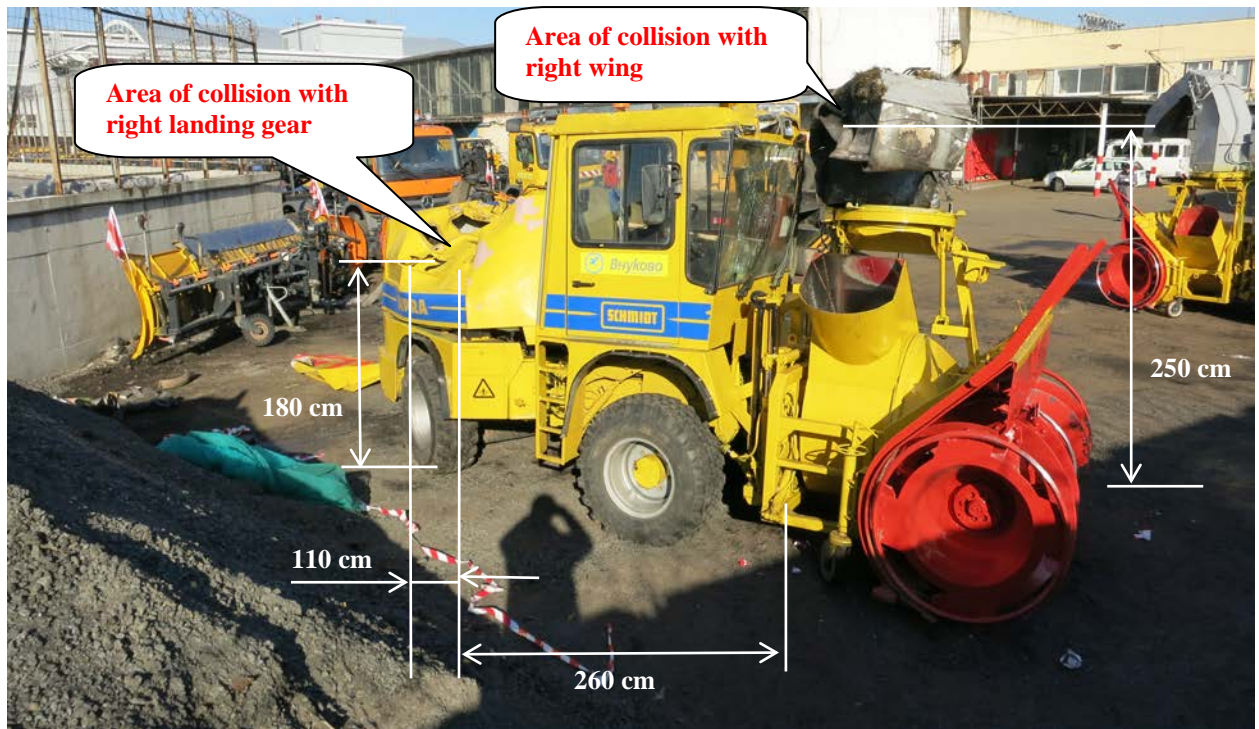

Figure 46a. Snowplow after the accident (the damaged snow evacuation nozzle was placed at its location as per design)

1.13. Medical and Pathological Information

According to Conclusion № 8221, the PIC's death occurred almost immediately as a result of blunt-force injuries causing death. Judging by the nature and location of the injuries, at the time of the accident the PIC was in the LH pilot seat, with the safety harness fastened. The forensic chemical body blood analysis did not reveal any ethyl alcohol or carboxyhemoglobin. No alcohol was either revealed in the urine.

According to Conclusion № 8220, the FO's death occurred within a short-time period (counted in tens of seconds) as a result of multiple injuries combined with the factors of open fire and combustion products in the ground fire cell, confirmed by intravital upper air passages burns, presence of soot in the trachea and main bronchi lumens, as well as toxic concentration of carboxyhemoglobin of 40% in blood. The combination of the revealed mechanical injuries does not contradict the fact that at the time of the accident the FO was in the RH pilot seat fastened with the safety harness. The forensic chemical blood and urine analysis did not reveal any alcohol. Taking into account the extreme severity of the sustained injuries as well as the death tempo (just tens of seconds) it was impossible to deliver timely medical assistance to the FO at the accident site.

According to Conclusion № 8222, the flight attendant's death occurred almost immediately as a result of blunt-force injuries causing death. The forensic chemical body blood

analysis did not reveal any ethyl alcohol or carboxyhemoglobin. No injuries typical of safety harness traumatic effect were found on the flight attendant's body.

According to Conclusion № 8223 the passenger's death occurred almost immediately as a result of blunt-force injuries causing death. The revealed burns occurred after death, as the passenger's body was in the ground fire cell. No injuries typical of safety harness traumatic effect were found on the passenger's body.

1.14. Survival Aspects

At the time of the aircraft collision with the snowplow the PIC and F/O were in their respective seats with fastened safety harnesses. The flight attendant and passenger did not use the safety harnesses. The death causes were mentioned in the previous section.

The investigation team did not reveal any aircraft structure peculiarity that could have influenced the survivability of the passenger or the crew during the accident.

1.15. Search and Rescue. Fire Fighting Operations

On 20.10.2014 at 19:58:10 the observer of the departure search and rescue station 1 (DSRS 1) saw an explosion in the area of RWY 1 and alerted the search and rescue units of DSRS 1 by activating the aural alarm.

At 19:58:28 the alarm was started via the emergency alerting system Industronic.

At 19:58:34 the departure controller announced alarm via the emergency alerting system Industronic.

As the announcement was passing via the Industronic system the DSRS 1 observer used the speakerphone to notify the aerodrome fire unit crews: "Red Code".

At 19:58:59 the alarm had been finalized and the emergency information passed to all search and rescue units.

At 19:59 after being notified via the Industronic system, the SRS head of shift - search and rescue operations supervisor set off for the accident site.

20:00 - 20:01 - the firefighting units from DSRS 1 arrived at the accident site and started extinguishing the fire on the accident aircraft.

By the time the firefighting units arrived at the accident site the aircraft was on the right clearway of RWY 1, inverted and broken into five basic parts: fuselage with RH wing and one engine, LH wing, two engines and tail empennage.

The first firefighting unit arrived at 20:00 on an OSHKOSH STRIKER 6x6 truck, garage number 615, and accomplished immediate foam attack from turntable nozzle to extinguish the fire in the cabin area.

The second firefighting unit arrived at 20:00 on an IVECO Magirus ARFF 12000 truck, garage number 617, and accomplished immediate foam attack from turntable nozzle to extinguish the fire in the cabin area and foam the fuel spill to prevent it from igniting.

The third firefighting unit arrived at 20:00 on an IVECO Magirus ARFF 12000 truck, garage number 616, uncoiled the main and line sleeves and was extinguishing the fire and cooling the aircraft with use of manual hoses.

The fourth firefighting unit arrived at 20:00 on an AA-8.0/55 (4320) truck, garage number 621, and took part in extinguishing a detached engine.

The fifth firefighting unit arrived at 20:01 on an AA-8.0/55 (4320) truck, garage number 624, and was present at the accident site as reinforcement.

After the alarm was announced firefighting units from DSRS 2 supervised by the division commander set off for the accident site on two AA-8.0/55 (4320) trucks, garage numbers 618 and 619. 20:03 - the firefighting units from DSRS 2 arrived at the accident site.

The firefighting units from DSRS 2 did not take part in firefighting operations and were carrying duty at the accident site as reinforcement.

20:05 - Flight Safety Inspection of Vnukovo AP and a medical service unit of Vnukovo AP arrived and the medical aid ground was arranged.

The fire was localized; the fuselage and detached engine were still being extinguished.

The cut-in areas were determined as the fuselage was highly deformed. The search and rescue units started cutting in the aircraft to evacuate the passengers and crew.

20:06 - an aerodrome service unit and communication service unit of Vnukovo AP arrived.

20:07 - security units of Vnukovo AP JSC, fueling service unit (TZS LTD) and Service Aircraft LTD arrived.

20:10 - lighting service units of Vnukovo AP JSC arrived.

As the passageways to access the passengers and crew were cleared, the search and rescue units retrieved the passenger and crew's personal belongings, as well as documentation.

20:17 - the fire had been extinguished, the rescue service started cutting in the cockpit with chain saws. Simultaneously, the main entry door and fuselage skin was being cut in several places.

20:28 - three brigades from Scientific and Practical Center of Medical Emergency Service arrived.

20:38 - after the main entry door was cut-in the flight attendant was found lying head first, not fastened, in the nose part of the cabin and retrieved. The medical unit doctor stated biological death.

20:50 - after the cockpit was cut in and the safety harnesses cut on the LH pilot seat, the PIC was retrieved from the cockpit. The medical unit doctor stated biological death.

20:55 - after the safety harnesses was cut on the RH pilot seat, the FO was retrieved from the cockpit. The medical unit doctor stated biological death.

At 21:18, after cutting in the fuselage skin in the cabin area, and clearing the way, the passenger was found in the center of the cabin, lying head down, not fastened. The medical unit doctor stated biological death.

23:35 - alarm terminated for the search and rescue units of Vnukovo AP.

The fire was extinguished by foam attack from turntable nozzles, after quenching and cooling was done using manual hoses. The agents applied were the PO-RZF and PO-RZA foaming agents and water.

The search and rescue operations were conducted by human forces and vehicles of Vnukovo AP Search and Rescue Team. 72 persons and 16 vehicles were involved in the fire fighting and rescue operations.

Search and rescue operations including firefighting operations at the accident site were arranged and conducted by SRS as well as Search and Rescue Team of Vnukovo Airport JSC in accordance with the Emergency Response Plan of Vnukovo AP JSC.

The time of notifications and search and rescue units arrival complied with the regulatory norms.

1.16. Tests and Research

1.16.1. Fuel and Oil Examination

The investigation team took fuel samplings from the fuel truck as well as the fuel filters of the Falcon 50 EX three engines to be thoroughly analyzed at the fuel laboratory of State Science and Research Institute of Civil Aviation. The analysis of the TS-1 fuel samplings taken from the fuel truck as well as the fuel filters of the Falcon 50EX three engines revealed that the kerosene complied with the State quality standards.

The investigation team took oil samplings from the engines to be thoroughly analyzed at the fuel laboratory of State Science and Research Institute of Civil Aviation. The analysis of the oil samplings taken from the engines revealed that the oil complied with the applicable quality standards.

1.16.2. Snowplow Lights Examination

According to Conclusion № 9634-AK/103 of State Center of Flight Safety as of 14.11.2014 based on the special examination of electric lights of the SUPRA-5001 snowplow, at

the time of its collision with the Falcon 50EX F-GLSA aircraft, the snowplow lights (Figure 46b and Figure 46c) were in the following condition:

- strobe light, right dipped headlight and left far-reaching headlight, left aft clearance and stop light, left forward clearance light and aft operational light were lit;

- projector light, right and left reverse movement lights, left and right turning lights, right aft clearance and stop lights, and aft operational light bulbs did not reveal any signs of filament destruction or being under voltage.

Other lights were missing.



Figure 46b. Snowplow lights schematic (forward)



Figure 46c. Snowplow lights schematic (aft)

1.16.3. Examination Conducted in France

Upon the investigation team request the aircraft manufacturer conducted takeoff performance simulation. The purpose of the simulation was to assess the takeoff performance of the aircraft and the possible scenarios in case of rejected takeoff at different times. The simulation took into account the actual weather conditions and the runway slope.

The normal takeoff computations revealed that the distance travelled until liftoff was 868 m, which is well compatible with the FDR data (845 m) and shows that the aircraft takeoff performance was as per design. The takeoff distance (until reaching a height of 35 ft) was 1076 m.

Rejected takeoff scenario was simulated for three different runway conditions:

- 1 mm wet snow (as per ATIS information);
- wet;
- dry.

Two crew phrases were considered as possible start of rejected takeoff: *"What's the car crossing the road?"* and *"My control"*. It was assumed that the snowplow was located about 948 m from the position the aircraft was at the start of the takeoff run.

The rejected takeoff procedure was simulated in the following sequence:

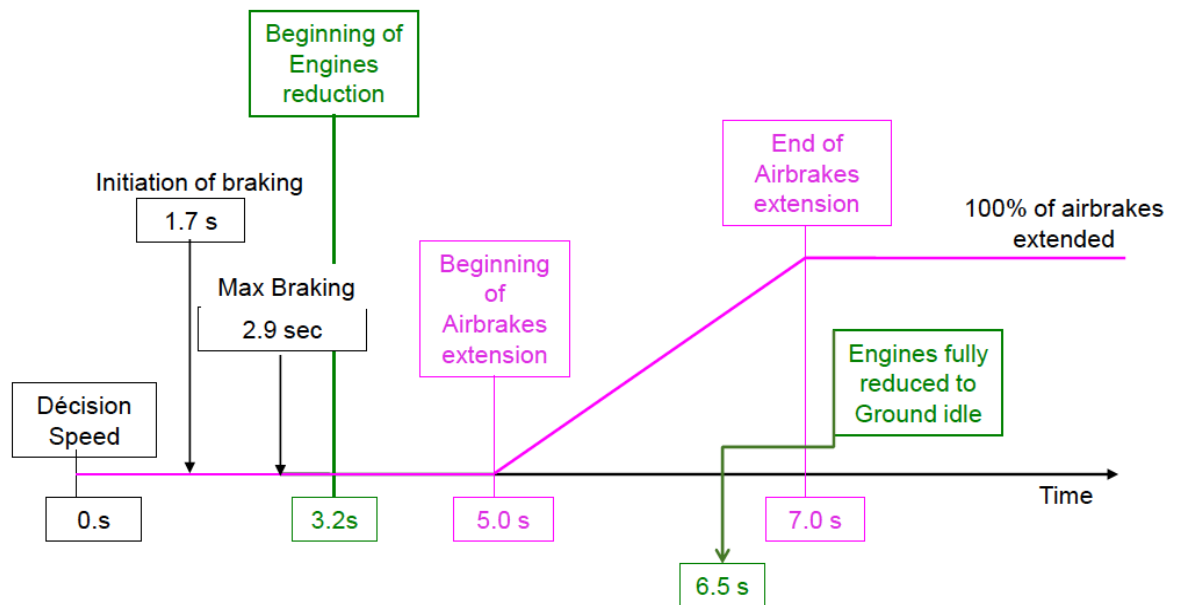

The computation results are shown in the table below.

	Distance travelled (meters)	Accelerate Stop distances (meters)		
		1 mm wet snow	Wet	Dry
<i>RTO "What's the car crossing the road?"</i>	260	970	936	670
Ground speed (knots)	-	21	0	0
<i>RTO "My control"</i>	434	1425	1337	989
Ground speed (knots)	-	80	72	30

Based on the simulation, the aircraft manufacturer concluded that the crew would not have been able to stop the aircraft before the snowplow with a 1 mm wet snow contaminated runway even if they had rejected takeoff at the moment they first noticed the snowplow. The speed of collision in this case could have been approximately 20 knots (approximately 37 km/h).

However, the investigation team notes that according to the airfield surveillance and control subsystem A3000 data, the aircraft takeoff run started at a distance of 590 m from RWY 06 threshold. According to the wreckage plot and data from the airfield surveillance and control subsystem the aircraft collided with the snowplow at a distance of 1570 m from RWY 06 threshold. These data are confirmed by the computations of the aircraft path during takeoff run made based on the FDR data.

Thus, at the time of the collision the snowplow was not at a distance of 948 m as assumed during the simulation, but at the distance of 980 m from the start of the takeoff roll. Thus, most probably, the crew might have been able to stop the aircraft before the snowplow with a 1 mm wet snow contaminated runway if they had rejected takeoff at the moment they first noticed the snowplow.

Note: In accordance with the specifications of the airfield surveillance radar, the accuracy of positioning of the displayed target lies within a distance of 3 m and azimuth of 0.05° (Para 6.6.6.2b of Doc 306405-TG, Rev: A). The distance between the antenna and the intersection of RWY 1 and TWY A11 is about 2200 m.

Besides, the rejected takeoff simulation did not take into account the effect of the central engine thrust reverse, though thrust reverse application was prescribed by the rejected takeoff SOP.

AFM

Rejected Takeoff before V1

- Brakes pressure	Maximum
- Power levers	Idle
- AIRBRAKES handle	Position 2
- Thrust reverse	Full

Usage of thrust reverse would have additionally shortened the rejected takeoff distance. Upon request of the investigation team on the need to simulate rejected takeoff with thrust reverse the manufacturer responded that the aircraft certification (including takeoff and landing performance) was accomplished without taking into account the use of thrust reverse, meaning the manufacturer did not have respective performance data to conduct the requested simulation.

Thus, based on the simulation, the investigation team has arrived to a general conclusion that most probably the crew might have prevented the fatal outcome in case they had performed

rejected takeoff procedure as soon as they were first aware of the snowplow. In this case the aircraft would have either stopped before reaching the snowplow or its speed would have been insignificant either making it possible to turn off or at least avoid the fatal accident.

1.16.4. Examination Conducted in the Netherlands

In order to confirm the video information shown on TRADIS indicators at ground and departure controllers and shift supervisor's working positions during the accident, the investigation team provide archive data recorded on 20.10.2014 by the airfield surveillance and control subsystem A3000 to the DSB (the Netherlands).

The DSB, in cooperation with the system designer, replayed the information and provided the investigation team with pertinent outcomes.

It was noted therewith that the software configuration installed at Vnukovo AP at the time of the accident did not ensure replay of entire radar information. In particular, the replay did not show the alarms shown on the TRADIS screens during the accident flight. As this was discovered, the replay configuration was adapted using an additional configuration file provided by the system manufacturer. As a result the investigation team received complete video information shown by the airfield surveillance and control subsystem A3000 on the TRADIS indicators located at ATC working positions during the accident. This information was used by the investigation team to analyze the accident causes and circumstances (see Section 2 of the Report).

1.16.5. ELT Examination

The aircraft was fitted with an ELT 97 (AF), MSN 2830 manufactured by AIR PRECISION (France), released in May 2008. The last inspection was accomplished by SATORI in December 2010, battery lifetime - before November 2014. The ELT is programmed using 24-bit protocol and has a 15-digit identifier 9C6DCE4B9000129 (FRANCE).

The COSPAS SARSAT system did not record any signal from the ELT during the accident. The wiring condition between the ELT and the external antenna after the accident was found to be satisfactory and signal continuity was established.

The ELT 97 (AF) has a G-switch for automatic activation in accordance with EUROCAE ED-62 standard and is programmed to activate when 2.3 ± 0.3 g is detected. Activation is based on an aircraft translational stop along the longitudinal aircraft axis.

The ELT examination was conducted at the facilities of Innovation Technology LTD authorized to programming of that ELT model. The examination was conducted with the help of the programmer ELT96A9800000003 s/n 51 and COSPAS SARSAT tester BT100AV triple s/n 3019 by WS Technologies Inc.

There were no external damage to the ELT, its casing was not exposed to open fire and had no traces of thermal damage. The ELT control panel was in satisfactory condition, showing no visual sign of breakage of antenna or commutation connector. The mode switch was operable and could be fixed in three positions (MAIN RESET/OFF/AUTO) as per design.

As the COSPAS SARSAT tester was connected, there was a steady signal at 406 MHz. It was not possible to receive steady signal at 121.5 and 243.0 MHz.

As the programmer was connected to the commutation connector of the ELT, the software showed a message that it was impossible to establish connection between the programmer and the ELT.

Thus, during the examination of the ELT 97 (AF) after the accident it was impossible to readout detailed ELT performance and assess them using the available tools.

1.17. Organizational and Management Information

Aerodrome servicing at Moscow A/D (Vnukovo) is provided by the aerodrome service, which is an independent department of Vnukovo Airport JSC. Certificate of Compliance № FATA A.01.02549 was issued by FATA to Vnukovo Airport JSC on 01.10.2012. Valid till 01.10.2015.

Operational control of commercial air transportation at Moscow A/D (Vnukovo) is provided by VIPPORT LTD holding Certificate of Compliance № FATA II.01.00325 issued by FATA on 01.10.2013 valid till 01.10.2015.

Passenger and baggage handling at Vnukovo AP for domestic and international flights is provided by Business Aviation center LTD holding Certificate of Compliance № FATA A.02.02680 issued by FATA on 07.02.2013. Valid till 07.02.2016.

Aerodrome ATC in Vnukovo airdrome terminal area within the ATC zone is provided by staff of Vnukovo ATC Center, Moscow ATM Center, State ATM Corporation. Certificate of Compliance № AHO.II 000510 issued by FATA on 03.07.2014 valid till 03.07.2016. Unijet airline is a holder of AOC № F-N 052, issue 3. The AOC was issued by the DGAC on 28.06.2013. The AOC is valid till 28.10.2014. Unijet address: Paris Le Bourget, PO 184 93352 LE BOURGET CEDEX, France. Telephone: +33 (0)1 48 35 99 12, Fax: +33 (0)1 48 35 86 64, email: ops@unijet.fr.

1.18. Additional Information

1.18.1. Aerodrome Air Traffic Control

On 20.10.2014 shift № 3 was on duty in the Tower consisting of 13 persons including a trainee controller.

At the time of the accident the following persons were at their working positions:

- supervisor's WP - ATC shift supervisor;
- departure control WP - instructor controller and trainee controller;
- ground control WP Ground 1 - controller 4;
- landing control WP - controller 2;
- joint approach control WP - controller 3.

Other controllers were having regulated rest in the recreation room.

ATC shift supervisor's working position

The equipment location at the supervisor's WP is shown in Figure 47.

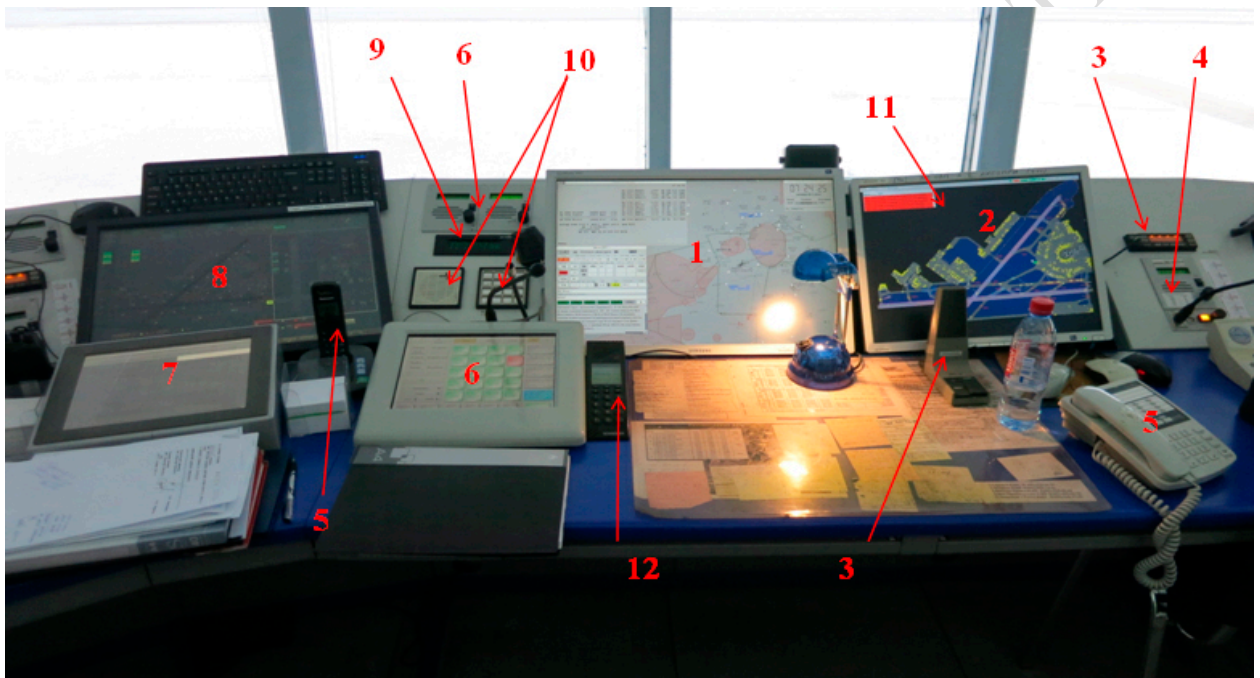

Figure 47. Supervisor's WP equipment

- 1 - Synthesis-A2 (Vn) indicator;
- 2 - TRADIS (Terma Scanner) and weather indicator;
- 3 - Kenwood radio station;
- 4 - Megaphone voice commutator (remote control emergency communication);
- 5 - phones;
- 6 - Megaphone voice commutator;
- 7 - Local Control and Correction Station LCCS-A-2000 indicator;
- 8 - Siemens RWY 1 Lighting Control;
- 9 - Metronom accurate time system;
- 10 - Industroffic emergency notification equipment;
- 11 - AMICPTC indicator (second screen input);

12 - SCHNEIDER communication equipment.

Note: *The selection of either radar or AMICPTC information to be shown on the screen is conducted by pressing a pressbutton on the indicator.*

The screen deployment was made by maintenance personnel of Vnukovo ATC Center upon oral direction of the Head of Air Traffic Service, Vnukovo ATC Center agreed with the Head of Vnukovo ATC Center.

Provision of weather information through the second input of the screen limits the radar information indication capability of the A3000 subsystem: observation of meteorological information at the supervisor's WP prevents using within the same time the A3000 system for its intended function - monitoring of aircraft and vehicles movement on the RWYs and TWYs is not possible.

Supervisor's WP Certificate of Operational Feasibility № AHO.O 004137 issued by FATA on 22.08.2013 valid till 22.08.2015.

The supervisor's activities are regulated by the following document: Quality Management System. JD-GK-1616.01-683. Job description of ATC shift supervisor, Vnukovo ATC Center. Approved by Moscow ATM Center Director, ATM State Corporation as of 10.04.2014.

In accordance with Para 1.8 of the job description the supervisor supervises the shift personnel activities, ensures ATC via departure control, standby departure control, landing control and ground control within the established zone boundaries and altitudes.

In accordance with Para 2.34 of the job description, the supervisor shall monitor the shift activities, especially at night time. In case a controller performs actions hazarding safety of flight operations the supervisor shall immediately suspend the former from their duties and report this to the Head of Air Traffic Service.

Departure Controller

At 19:05 two working positions were united: WP of departure ATS controller and WP of departure ATC controller. The ATM was conducted from departure ATC WP.

The equipment location at the departure ATC controller's WP is shown in Figure 48.

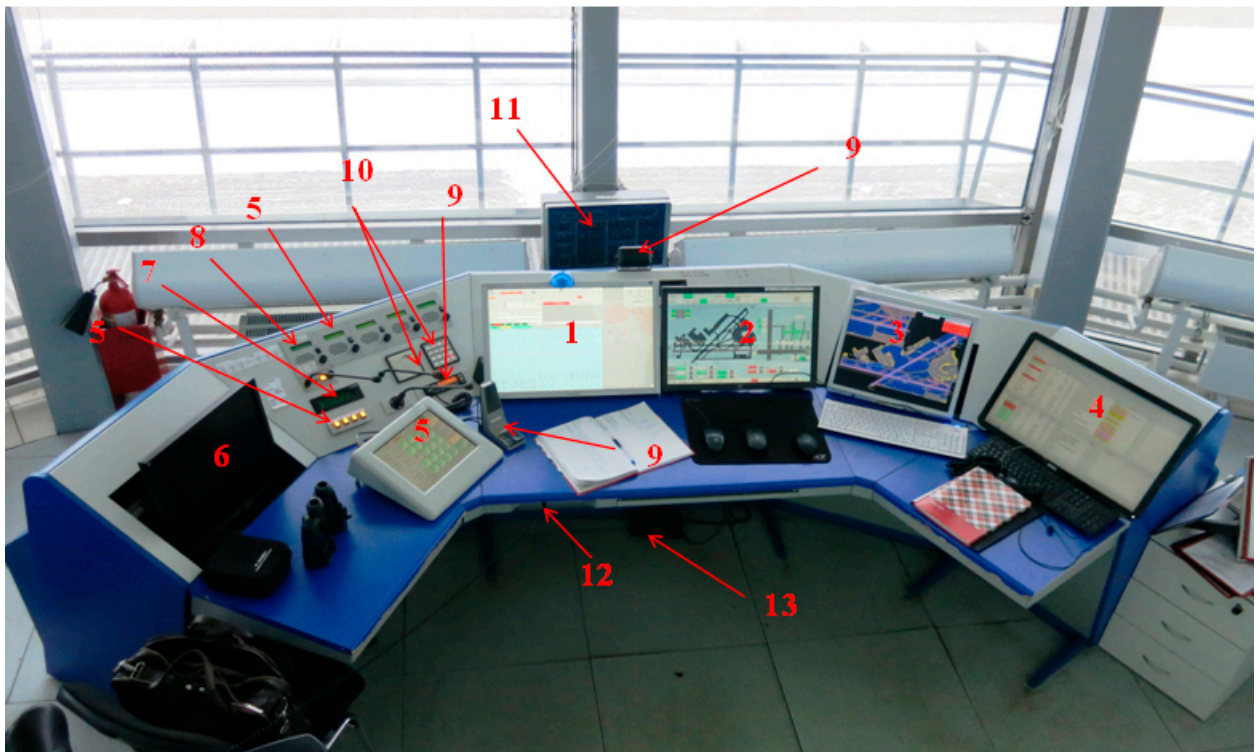

Figure 48. Departure Controller's WP equipment

- 1 - Synthesis-A2 (Vn) indicator;
- 2 - RWY 1 Lighting Control;
- 3 - TRADIS (Terma Scanner);
- 4 - Inform GS Automated Control System (information from Vnukovo AP JSC);
- 5 - Megaphone voice commutator;
- 6 - AMIS-RF indicator, METEO standby
- 7 - Metronom accurate time system;
- 8 - Megaphone voice commutator (remote control emergency communication);
- 9 - Kenwood radio station;
- 10 - Industronnic emergency notification equipment;
- 11 - AMIS-RF indicator, not used
- 12 - headset connectors;
- 13 - foot-activated force stick (radio communication);

It is impossible to manage the TRADIS system from the working position of the ATC Departure Controller (as was described in Section 1.8.2.1 it is only possible to manage it from the ATS Departure Controller's working position).

Departure Control's WP Certificate of Operational Feasibility № AHO.O 004139 issued by FATA on 22.08.2013 valid till 22.08.2015.

The Departure Controller refers to the following documents to perform his functions:

1. Quality Management System. JD-GK-1616.01-686. Job description of departure controller, air traffic service, Vnukovo ATC Center. Approved by Moscow ATM Center Director, ATM State Corporation as of 16.10.2012.

2. Quality Management System. WI-GK-1616.01-002. Working instruction of departure controller, air traffic service, Vnukovo ATC Center. Approved by Order № 295 of Moscow ATM Center Director, ATM State Corporation as of 31.03.2014.

Departure Controller's Duties

In accordance with Para 1.6 and 1.7 of the Working instruction of the departure controller, it is possible to unite the functional duties of the ATS controller and ATC controller, if only one controller is working, the ATC controller unites his duties with the duties of ATS controller.

In accordance with Para 1.10.2, ATS controller monitors the runway occupation and provides information to the ATC controller if there are no obstacles on the runway using visual control within the visibility range, data from airfield surveillance and control subsystem A3000 of the A-SMGCS system as well as reports from crews and persons handling radio communication on aerodrome vehicles.

In accordance with Para 1.12 the ATC and ATS controllers shall:

- provide air traffic service... using ATC observation systems (Synthesis-A2 (Vn), A3000 A-SMGCS) flight plan system Synthesis-A2 (Vn), communication means and flight crew reports.

- control the aerodrome vehicles traffic that enters runways, using the airfield surveillance and control subsystem A3000 of the A-SMGCS system, internal airport communication means, visual control and reports of accountable persons.

Departure controller's duties during aircraft departure are determined in Para 5.2.1. of the Working Instruction of Departure Controller:

According to Para 5.2.1.1, during aircraft departure the ATC controller shall: "...identify the taxiing aircraft using visual control, data of A-SMGCS A3000 and aircraft data in the flight plan information window in Synthesis-A2 (Vn) system and in the departure information window of A-SMGCS A3000.

In accordance with Para 5.2.1.15, "absence of obstacles on the airstrip is determined by the ATC controller using visual observations, data from A-SMGCS A3000 as well as reports provided by aircrews, accountable person for the airstrip servicing and the ATS controller.

If the cloudbase is 200 m or lower and/or the visibility is 2000 m or lower, at night time or if there are no data from the A-SMGCS A3000 system, the invisible portions of the runway can be inspected by the ATC controller upon command of the supervisor using the control car."

In accordance with Para 5.2.1.16, "in case the ATC controller after issuing clearance for takeoff detects runway incursion or inevitability thereof, ..., which can create a safety hazard to the departing aircraft, the ATC controller shall do the following:

- cancel takeoff clearance;
- ...
- in any case the aircraft crew shall be informed on the runway incursion or obstacle and its location related to the runway."

In accordance with Para 5.2.1.17, "in case the ATC controller is aware that an aircraft or vehicle experiences disorientation or is not completely aware of its position on the airfield, the controller shall immediately take pertinent measures to provide safety of operations and assist the relative aircraft or vehicle to identify their location".

In accordance with Para 5.9., the radar of the airfield surveillance and control subsystem A3000 of the A-SMGCS shall be used in addition to visual observation of traffic on the maneuver area as well as to ensure traffic observation of those areas that cannot be observed visually.

In accordance with Para 6.11.1 in case "after the takeoff clearance is issued a departure controller detects (visually or by A-SMGCS A3000 indicator) runway incursion or inevitability thereof, ..., that can create safety hazard to the departing ... aircraft, the ATC controller shall:

- prohibit takeoff of the departing aircraft (if the aircraft has not started takeoff roll);
- inform the crew of the taking off aircraft on the safety hazard (if the aircraft has started the roll).

In accordance with Para 7.1, absence of obstacles on the airstrip is determined from the working position of the Tower ATC controller visually (within visibility range) and with use of data from A-SMGCS "A3000" as well as using reports provided by aircrews, and accountable person for the airstrip servicing.

Thus, during an aircraft departure the controller shall observe runway situation visually within the visibility range, using the A-SMGCS A3000 and using reports from crews and persons responsible for the operations.

Trainee Controller Duties:

The basic duties, functions, rights and responsibilities of a trainee controller are determined by Job description of trainee controller, Air Traffic Service, Vnukovo ATC Center approved by Director of Moscow ATM Office, State ATM Corporation.

A trainee controller's activities are regulated by:

- the working instruction of the control center where on-the-job training is conducted;

- their job description.

A trainee controller is directly accountable to the shift supervisor of the center's air traffic service, and operationally subordinate to the instructor controller who conducts the training.

A trainee controller undergoes on-the-job training under the supervision and control of the instructor controller at the ATC center defined by the corporate order.

Ground 1 Control

Ground Control's WP Certificate of Operational Feasibility № AHO.O 004136 issued by FATA on 22.08.2013 valid till 22.08.2015.

There are two WP at the Ground 1 control:

- on the LH side - ground controller providing ATC (Ground 1 ATC);
- on the RH side - ground controller providing coordination with ground handling services and airdrome vehicles (Ground 1 V).

At 19:10 the functions of Ground 1 ATC and Ground 1 V were united. The location of the equipment at Ground 1 Control where Ground 1 ATC controller was seated is shown in Figure 49.

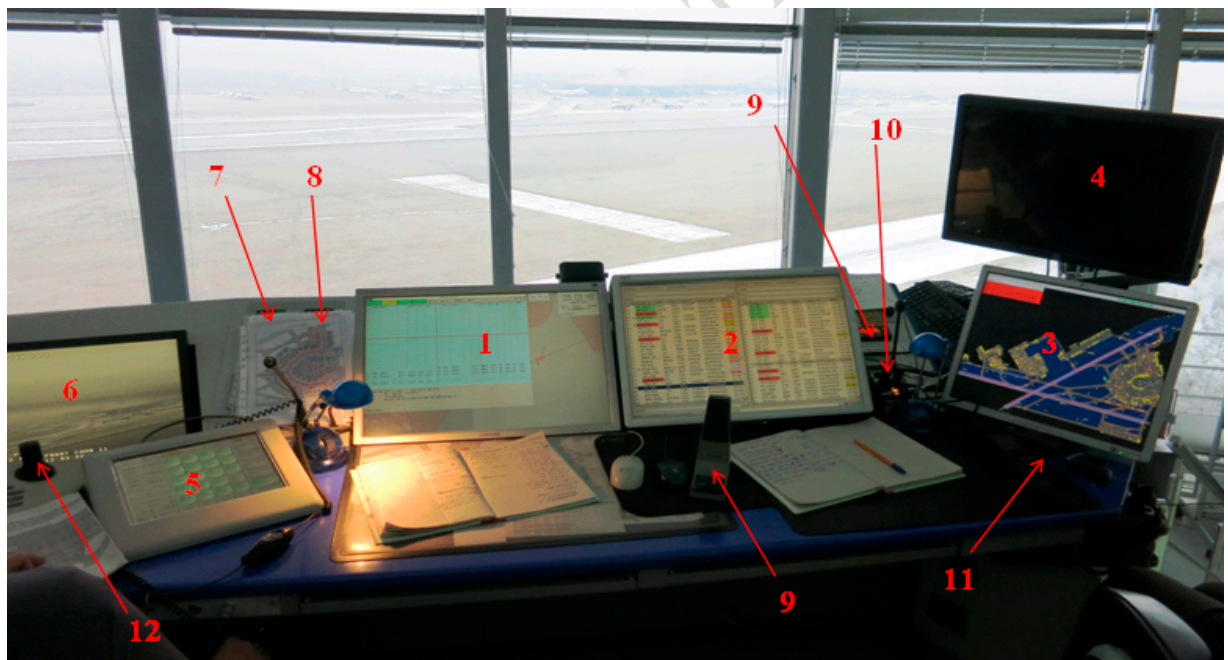

Figure 49. Ground 1 Control WP;

- 1 - Synthesis-A2 (Vn) indicator;
- 2 - Inform GS Automated Control System (information from Vnukovo AP JSC);
- 3 - TRADIS (Terma Scanner);
- 4 - RWY 1 Lighting Control;
- 5 - Megaphone voice commutator;
- 6 - video camera indicator;

- 7 - Metronom accurate time system;
- 8 - Industronnic emergency notification equipment;
- 9 - Kenwood radio station;
- 10 - Megaphone voice commutator (remote control emergency communication);
- 11 - SCHNEIDER communication equipment.
- 12 - video camera control stick.

Ground Controller Documentation;

1. Quality Management System. JD-GK-1616.01-688. Job description of ground controller, air traffic service, Vnukovo ATC Center. Approved by Moscow ATM Center Director, ATM State Corporation as of 16.10.2012.

2. Quality Management System. WI-GK-1616.01-001. Working instruction of Ground 1 controllers, air traffic service, Vnukovo ATC Center. Approved by Order № 295 of Moscow ATM Center Director, ATM State Corporation as of 31.03.2014.

3. Quality Management System. WI-GK-1616.01-002. Working instruction of Ground 2 controllers, air traffic service, Vnukovo ATC Center. Approved by Order № 295 of Moscow ATM Center Director, ATM State Corporation as of 31.03.2014.

Ground Controller Duties:

The duties of Ground 1 ATC and Ground 1 V are determined in Section 5 of the Working instruction of ground controllers.

In accordance with Para 5.5 of the Working instruction of ground controllers upon aircrew request for clearance to taxi to holding position the Ground 1 controller shall:

- ensure there are no obstacles along the aircraft taxiing route by visual observation (within acceptable visibility range), information from aircrew report, radar information (if available) and report of the follow-me car driver (if used);

- monitor the aircraft movement along its taxiing route based on the information from aircrew reports, radar information (if available) and/or report of the follow-me car driver until the aircraft is at holding position. The person responsible for the safe taxiing of the aircraft from the stand is the official ensuring aircraft dispatch or, if the latter is not present, the PIC.

In accordance with Para 5.14.2 of the Working Instruction, the Airfield Surveillance Radar with the airfield surveillance and control subsystem A3000 of the A-SMGCS shall be used in addition to visual observation of traffic on the maneuver area as well as to ensure traffic observation of those areas that cannot be observed visually.

In accordance with Para 5.14.3 of the Ground Controllers work instruction, information shown at the A-SMGCS indicator shall be used to:

- a) ensure monitoring of aircraft and vehicles in the maneuverable area in terms of their compliance to clearances and guidance;
- b) identify if the runway is clear before takeoff or landing;
- c) get information on the basic traffic in the maneuverable area or near it;
- d) identify aircraft and vehicle location in the maneuverable area.

Thus, in accordance with the working instruction, during an aircraft taxiing the ground controller shall observe the maneuvering area both visually, within the visibility range, and using the A-SMGCS A3000 system. Additionally they are to use reports from crews and persons responsible for the operations.

1.18.2. On-the-Job Training Arrangements

The on-the-job induction training of ATC personnel was conducted in accordance with Order № 93 of the Russian Ministry of Transport as of 14.04.2010 "On Approval of the Regulation of the Functioning of Continuous Professional Training System Including Licensing, On-the-job Training, Indoctrination, Recurrent Training Intervals of Management Personnel and Controllers".

The trainee controller's on-the-job training was conducted as per Order № 742 of Moscow ATM Center Director, ATM State Corporation as of 06.08.2014. The above order assigned the trainee controller to the out of staff instructor controller of Vnukovo ATC Center and determined the OJT period from 07.08 to 31.12.2014.

Note: *Supplement to Order № 93 of the Russian Ministry of Transport:
Amount of on-the-job training of ATC personnel to be authorized for
the job:*

<i>ATC center name</i>	<i>Time of training (hours)</i>		<i>Time of familiarization with other control centers, hours</i>
	<i>Working position</i>	<i>ATC simulator</i>	
<i>Departure control</i>	<i>200</i>	<i>10</i>	<i>70</i>

An OJT log was created for the trainee controller containing the OJT schedule.

The OJT program, required by Supplement to Order № 93 of the Russian Ministry of Transport, was not submitted to the investigation team.

Note: *Supplement to Order № 93 of the Russian Ministry of Transport:
Para 12. There shall be a log, training program and training
schedule for each trainee controller.*

The OJT training consists of preliminary and practical training.

The OJT log of the trainee controller was approved by the Head of Vnukovo ATC Center as of 07.08.2014. It determined the OJT time of 280 hours including 50 hours of preliminary training and 230 hours of practical training, which complies with the OJT amount established by Order № 742 of Moscow ATM Center Director, ATM State Corporation as of 06.08.2014.

In violation of Para 7.1 Section 10 of the Provision on ATC Simulator Training Arrangement and Conduct for Personnel of State ATM Corporation, only 10 hours were scheduled for the simulator training and 2 hours for the simulator skill check instead of having complete simulator training to accomplish Tasks 1 to 4 (24 hours).

Note: *Provision on ATC Simulator Training Arrangement and Conduct
for Personnel of State ATM Corporation, approved by Order
№ 182 of General Director of State ATM Corporation as of
16.04.2014.*

Para 7.1. Authorization for independent work.

*To get an initial authorization for independent work simulator
training shall be conducted in full according to the complete list of
tasks (1 to 4) with mandatory completion of two check exercises as
part of Task 3 and 4.*

Preliminary Training

Trainee controller's preliminary training was conducted from 07.08 to 25.08.2014 comprising 40 hours instead of the scheduled 50 hours.

Note: *1. Supplement to Order № 93 of the Russian Ministry of Transport:
"Time of OJT and familiarization with other ATC units activities
(except Para 7) can be reduced by 30% by the employer's decision
if the trainee controller has undergone university field and pre-
graduation practice at the pertinent ATC center and had positive
reviews.*

*2. The trainee controller underwent pre-graduation practice at
Moscow ATM Center, State ATM Corporation from 03.06.2013 to
26.07.2013 (Order № 414 as of 03.06.2013) and from 04.02.2014 to
09.03.2014 (Order № 93 as of 05.02.2014).*

On 25.08.2014 the instructor controller checked knowledge of the trainee controller and concluded she was ready for the practical training making the relative record in the OJT log.

Note: *Extract from the OJT log of the trainee controller:
Instructor conclusion on access to practical training: "Theoretical training passed in full. Can be admitted to practical training".*

Practical Training

The trainee controller started her practical training on 26.08.2014 as the instructor controller showed her how departure controller's duties are to be performed.

The practical training schedule assumed 234 hours of training including 100 hours of OJT at the departure control working position and 10 hours of simulator training.

It should be noted that the trainee instructor's practical training schedule in the OJT log did not show days and hours and, in violation of Order № 93 of the Russian Ministry of Transport, it was not approved.

Note: *Supplement to Order № 93 of the Russian Ministry of Transport:
Para 18. Practical training shall be conducted on ATC simulator and at working position in accordance with an approved schedule and include a demonstration of the ATC function by the instructor controller, work of the trainee controller as an ATC controller under the supervision of the instructor controller, familiarization with the work of other ATC units, debriefing of typical mistakes as well as simulator training und the supervision of simulator instructor".*

On 19.08.2014 the trainee controller underwent simulator training at the departure controller's WP on the Synthesis SC-V ATC Simulator of Vnukovo ATC Center, Moscow ATC Center subsidiary, State ATM Corporation under the supervision of a simulator instructor.

The simulator training was conducted based on the training assignments signed and issued by the shift supervisor. It should be noted that all the 5 issued training assignments were identical. The training assignment form did not provide for filling in the task and exercise number. The absence of task and exercise number in the training assignments violates the methodology of the OJT training.

Within 19.08.2014 to 13.10.2014 the trainee controller underwent 10 hours of simulator training and completed Task 3 exercises (see table below).

Date	Task/ Exercise	Training contents
19.09.2014	3/5	Simultaneous air traffic management from 2 RWYs: RWY 01 - departure; RWY 06 - departure and landing
25.09.2014	3/6	Simultaneous air traffic management from 2 RWYs: RWY 19 - departure; RWY 24 - departure and landing
01.10.2014	3/4	ATM RWY 24 - departure and landing
07.10.2014	3/6	Simultaneous air traffic management from 2 RWYs: RWY 19 - departure; RWY 24 - departure and landing
13.10.2014	3/4	ATM RWY 24 - departure and landing

On 07.09.2014 the trainee controller started her OJT at departure controller working position under the supervision of the instructor controller. According to the OJT log, 3 hours of the OJT on 07.09.2014 for was devoted to practice of control panel operations to enter aircraft takeoff and departure times into Synthesis Alphascope and Synthesis A2 (Vn) software.

On the whole, 5 drill sessions were conducted. The total OJT time at departure controller working position since 07.09.2014 till the time of the accident, including the OJT time on the day of the accident was 17 hours 11 min, taking into consideration that on 20.10.2014 the trainee controller had her second nighttime OJT session (see the table below).

Date	OJT time	Part of the day	Duration of OJT at departure controller working position
07.09.2014	04:09 ÷ 06:24	daytime	2 hours 15 minutes
07.09.2014	07:11 ÷ 10:40	daytime	3 hours 29 minutes
18.10.2014	13:08 ÷ 18:43	1 hour daytime/ night time	5 hours 35 minutes
19.10.2014	04:02 ÷ 07:06	daytime	3 hours 04 minutes
20.10.2014	17:38 ÷ 20:26	night time	2 hours 48 minutes
Total			17 hours 11 minutes

Note: *Data in the table were withdrawn from the personal data protection tool of the Synthesis-A2 (Vn) system based on the records made by the instructor controller.*

There were no records of the date and time of the OJT sessions at the departure controller working station in the OJT log (there is no box for such records in the log).

1.18.3. Airfield Surveillance Radar System Training for Controllers

Initial training for engineers and controllers of Vnukovo ATC Center on the operation of the Terma Scanner 2001 Airfield Surveillance Radar and Airfield Surveillance and Control Subsystem A3000 Type 00-06-02 of the A-SMGCS System was conducted in October 2011 by the equipment supplier representatives. After the training the supplier representatives issued certificates to one instructor controller and two controllers. Other controllers of the Vnukovo ATC Center did not have documents confirming they had been trained to operate the Airfield Surveillance Radar System. As per the system supplier's information, certificates were only issued to those controllers who participated in the full operational training. Certificates were not issued to those individuals who attended part of the training only. However, as per the information from the management of Vnukovo ATC Center the equal amount of training was provided to all controllers and the reason why certificates was not issued to all of them was unknown.

Further training was conducted by Vnukovo ATC Center experts until the end of 2011 in accordance with the controller professional training plan of Vnukovo ATC Center approved by Head of Vnukovo ATC Center on 21.11.2011, which is confirmed by records in the internal training log. There are no regulations prescribing that certificates shall be issued on completion of new equipment operation training.

Since December 2012, as the Synthesis TC-V ATC simulator was introduced, further theoretical and practical training of controllers has been conducted with the use of the simulator including automated working positions of ground controller, departure controller and landing controller equipped with simulators of the Airfield Surveillance Radar System.

Extract from the Head of Vnukovo ATC Center Response № 1619-431 as of 25.12.2014:

"... The training of Vnukovo ATC Center staff started in October 2011 by a representative of the equipment supplier. Initial training of the Navigation Support Service engineers and ATC controllers was conducted. The training was conducted for a month according to the training program of the equipment supplier. Upon the completion of the training, as decided by the supplier's representative, only the instructor controller (name) and controllers (two names) were given certificates¹⁷".

1.18.4. Aerodrome Service Vehicles

As per Order № 3059/П of the General Director of Vnukovo AP as of 20.10.2014 all aerodrome vehicles were authorized for aerodrome operations in autumn 2014/winter 2015, and

¹⁷ As per the issued certificates, it was a SMGCS training (not A-SMGCS). The description of both systems can be found in ICAO Doc 9476 and 9830 respectively.

as per Order № 315 of the General Director of Vnukovo AP they were assigned to specific drivers of the aerodrome service.

The following vehicles were pertinent to the accident:

- a FORD RANGER of the Lead Engineer - Aerodrome Service Shift Supervisor (Figure 50), released on 2010, registered O178EH 197, state number 320;



Figure 50. The FORD RANGER of the Lead Engineer - Aerodrome Service Shift Supervisor

- FRESIAPF 1000 rotor snowplow, registered 77 HA 85, state number 360, driven by snowplow driver 1;

- SCHMIDT SUPRA-5001 rotor snowplow, registered 77 AX 7303, state number 378, driven by snowplow driver 2;

- SCHMIDT SUPRA-5001 rotor snowplow (Figure 51), registered 77 AX 7304, state number 377, driven by snowplow driver 3;

SCHMIDT SUPRA-5001 (snowplow 3) basic information:

Type and model:	Rotor snowplow, SCHMIDT SUPRA-5001
Year of release	2006
Manufacturer	«SCHMIDT WIENTERDIENST UND KOMMUNALTECHNIK» (Germany)
Certificate of Conformity	№ POCC DE. MP04. A07288, issued by «MADI-CERT» as of 18.10.2006
MSN (frame)	10189627601002
Engine	№ 94299000480009
Gearbox	Automated

Propulsion type	Wheel
Engine power	571.2 horsepower
Weight with snowplow	About 10800 kg
Maximum design speed	25 km/h
Overall dimensions (Length by Width by Height)	6700 x 2400 x 3585 mm

On 25.10.2006 the rotor snowplow SCHMIDT SUPRA-5001 was bought by Vnukovo AP from Torggrim Limited (Moscow).

Vehicle passport: 209919, issued on 20.10.2006.

Registration Certificate: Series VK № 112940, issued on 16.01.2007.

State registration: 77 AX 7304.

The snowplow dimensions are shown in Figure 52.

Notes: amber strobe lights installed (Figure 53).

The strobes activation switch is mounted in the snowplow driver's cab.



Figure 51. SCHMIDT SUPRA-5001 vehicle, state number 378 - identical to the SCHMIDT SUPRA-5001 snowplow, state number 377

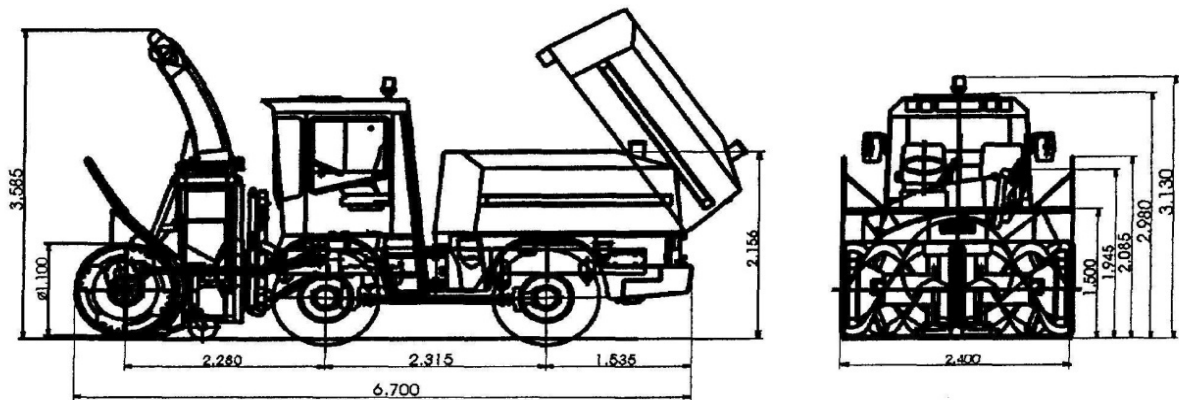

Figure 52. SCHMIDT SUPRA-5001 rotor snowplow overall dimensions



Figure 53. Strobe lights activation switch (marked with an arrow) on the cab control panel in the SCHMIDT SUPRA-5001, state number 377

All the above mentioned cars are equipped with Kenwood radio stations (Figure 54) tuned to the internal airport communication frequency:

- Ground 1, frequency 163.7 MHz;
- Ground 2, frequency 163.825 MHz;
- Departure, frequency 163.5 MHz;
- Airdrome Service, frequency 163.8 MHz;
- Vnukovo-3, frequency 163.5625 MHz;
- ASP, frequency 163.350 MHz.

The radio exchange is not recorded at Airdrome Service channel (163.8 MHz) and Vnukovo-3 (163.5625 MHz).

Note: *Extract from the Airdrome Service reference paper № 12.10-135 of Vnukovo AP as of 01.11.2014:*

The radio exchange at 163.8 MHz (AERODROME) and at 163.5625 MHz (Vnukovo-3) is not recorded.



Figure 54. Kenwood radio station in the cab of SCHMIDT SUPRA-5001, state number 377 (marked by the arrow)

As per Para 11.3 of the Airdrome Service and Vnukovo ATC Center Interaction Procedure the drivers of airdrome vehicles shall be constantly listening to the radio exchange on the Departure Control frequency. However, airdrome vehicles including snowplow 3 were not fitted with relative equipment.

The FORD RANGER, state number 320 of the airdrome service shift supervisor was additionally equipped with a radio receiver to monitor the radio exchange between aircrews and ground and departure controllers in the VHF range at the following frequencies:

- Departure, frequency 118.3 MHz;
- Ground 1, frequency 120.45 MHz;
- Ground 2, frequency 121.7 MHz;

Note: *Instruction № 82:*

Para 14. Airdrome vehicles driving out to runways or taxiways shall be equipped with clearance and strobe lights, radio stations of internal airport communication service, towing devices and

firefighting means.

The car of a person in charge of the airdrome operations shall be additionally equipped with a radio stations to monitor radio exchange at the departure and landing frequency.

The abovementioned vehicles were not equipped with GPS or transponders.

1.18.5. Safety Management System (SMS) at Vnukovo AP

Vnukovo AP JSC has developed and implemented since 01.01.2009 the Safety Management Manual of Vnukovo Airport Complex (Order № 420 of Vnukovo AP General Director as of 27.11.2008).

After the mentioned document was approved by Flight Safety Department, FATA the Safety Management Manual of Vnukovo Airport Complex was re-issued and approved by the General Director of Vnukovo AP as of 14.01.2011.

The SMS of Vnukovo Airport Complex serves to ensure a systematic approach to safety management in order to prevent accidents and incidents on the ground based on investigations findings.

Every year, in order to assess the risk based on the qualitative and quantitative safety performance indicators, a method described in the Safety Manual is used to assess the effect of known and identified hazards on the operational activity of the airport.

Risk Assessment at Vnukovo AP

In order to assess the safety risks a method described in the Safety Manual is used.

Likelihood assessment

Category A	1 or less occurrences per 400,000 flights
Category B	1 or less occurrences per 40,000 flights More than 1 occurrence per 400,000 flights
Category C	1 or less occurrences per 4,000 flights More than 1 occurrence per 40,000 flights
Category D	1 or less occurrences per 400 flights More than 1 occurrence per 4,000 flights
Category E	More than 1 occurrence per 400 flights

Probability chart for specific indicators

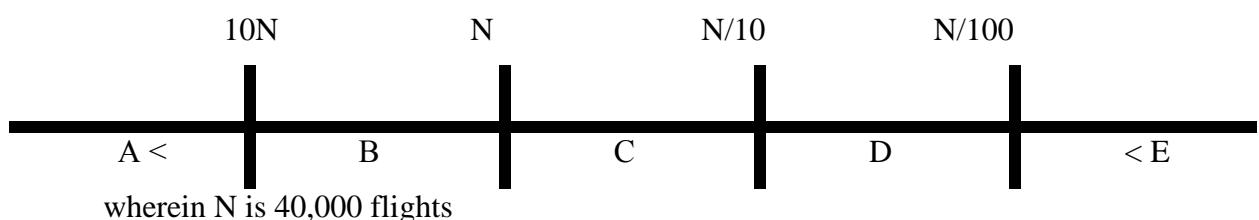

- Note:**
1. In order to compute the relative safety performance indicators the number of flights for 2014 was taken, making up 164,126 flights.
 2. The evaluation of quantitative performance indicators (number of occurrences per 40,000 flights) was conducted in accordance with ICAO recommendations.

Risk severity assessment

Class of severity	Severity	Safety impact
Class 5	Catastrophic	Direct threat to safety
Class 4	Hazardous	Severe impact
Class 3	Complicated	Major impact
Class 2	Circumstances getting complicated	Minor impact
Class 1	Potential occurrences	Minor impact on safety, but can lead to an occurrence with safety impact
Class of occurrence	Severity	
	People	Property
Class 5	Multiple fatal occurrences	Hull loss
Class 4	Likelihood of fatal occurrences	Major damage
Class 3	Severe injuries	Significant damage
Class 2	Minor injuries	Minor damage
Class 1	Negligible injuries	Negligible damage

Safety Performance Indicators, 2014

SPI	Overall absolute indicators	Number of occurrences per 40,000 flights	Likelihood	Severity
Accident - Falcon 50EX crash	1	0.24	Category B	Class 5
Damage to aircraft	7	1.71	Category C	Class 2
Unacceptable damage to engine blades	1	0.24	Category B	Class 2
Runway incursion	3	0.73	Category B	Class 3
Foreign objects on runway	3	0.73	Category B	Class 3
Bird strikes	9	2.20	Category C	Class 2

SPI	Overall absolute indicators	Number of occurrences per 40,000 flights	Likelihood	Severity
Violation of aircraft parking rules	3	0.73	Category C	Class 2
Violation of maintenance regulations	3	0.73	Category B	Class 2
Violation of refueling regulations	1	0.24	Category B	Class 2
Violation of aircraft embarkation/disembarkation rules	3	0.73	Category B	Class 2
Violations and discrepancies in airport preparation	5	1.22	Category C	Class 2
Transport left unattended on ramp	4	0.97	Category B	Class 2
Incursion of aircraft taxiing routes by vehicle drivers	15	3.66	Category C	Class 2
Violation of airdrome traffic rules	15	3.66	Category C	Class 2
Violation of vehicle documentation	4	0.97	Category B	Class 1
Release of malfunctioning vehicles to service	4	0.97	Category B	Class 2
Violation of aircraft towing rules	3	0.73	Category B	Class 2
Violation of airdrome traffic pattern	9	2.20	Category C	Class 2
Violation of vehicle parking rules	6	1.46	Category C	Class 2
Driving without medical check	2	0.49	Category B	Class 2

SPI	Overall absolute indicators	Number of occurrences per 40,000 flights	Likelihood	Severity
Violation of rules of operation in the aircraft safety area	8	1.95	Category C	Class 2
Staff performing duties without ID or other documents	9	2.20	Category C	Class 2
No firefighting aids on vehicles	12	2.93	Category C	Class 2
Unsatisfactory exterior of vehicles	9	2.20	Category C	Class 1

The safety performance indicators were substantially affected by the Unijet Falcon 50EX F-GLSA accident on 20.10.2014.

The analysis of SPIs revealed that safety at Vnukovo Airport is affected by the following hazards:

- damage to aircraft;
- bird strikes;
- violations and discrepancies in airport preparation;
- violation of vehicle parking rules;
- violation of rules of operation in the aircraft safety area;
- staff performing duties without ID or other documents;
- no firefighting aids on vehicles.

There was an increase in the number of occurrences related to bird strikes, and no decrease in the number of occurrences related to vehicles crossing taxiing routes and violation of aerodrome traffic rules.

The risk assessment at Vnukovo AP based on the 2014 data in accordance with the risk matrix (Tables 4 and 5) reveal that the number of occurrences require risk monitoring and control to ensure further improvement of operations for the following risks:

- unacceptable damage to engine blades;
- foreign objects on runway;
- violation of aircraft parking rules;
- violation of maintenance regulations;
- violation of refueling regulations;

violations and discrepancies in airport preparation;
transport left unattended on ramp;
release of malfunctioning vehicles to service;
violation of aircraft towing rules;
violation of airdrome traffic pattern;
driving without medical check;
drivers working overtime;
damage to aircraft;
violation of vehicle parking rules;
violation of aircraft embarkation/disembarkation rules;
violation of rules of operation in the aircraft safety area;
violation of vehicle documentation;
incursion of aircraft taxiing routes by vehicle drivers;
violation of airdrome traffic rules.

The following actions are required in such cases: occurrence investigations, discussion, monitoring and control to ensure improvement.

Runway incursion (Falcon 50EX F-GLSA accident) requires involvement of the Vnukovo AP top management into solving the issues and implementing safety recommendations of the investigation team.

After the accident the following preventive actions¹⁸ have been taken at Vnukovo AP to prevent runway incursions:

- Order № 340 of the Vnukovo AP, JSC General Director as of 06.11.2014 "On establishing the runway safety team at Vnukovo AP" issued;
- Runway Incursion Preventive Action Plan for Vnukovo AP elaborated;
- driver training programs revised. Drivers were subject to written testing during the seasonal training for spring-summer 2015;
- airfield signage check conducted. All runway signage was compliant with the Aviation Rules AR-139. The aerodrome was inspected by the Airdrome and Equipment Certification Commission IAC team and a new Certificate № 015 A-M was issued as of 15.01.2015.
- additional briefing provided to drivers as to the radio exchange at the airfield, testing accomplished and verified by signatures;

¹⁸ The information has been provided by the administration of JSC Vnukovo Airport.

- Procedures for Aerodrome Service Interaction with Vnukovo ATC Center and Other Ground Services at Vnukovo AP as well as Working Instruction of Follow-Me-Car Driver of Vnukovo AP Aerodrome Service revised in cooperation with Vnukovo ATC Center;
- beacon system critical area daytime signage drawn before the crossing on RWY 1 and RWY 2.

1.18.6. SMS in the Air Traffic and Radio Navigation Service of Vnukovo ATC Center

In 2014 in order to ensure the functionality of SMS, an Air Navigation Service Safety Management Manual of State ATM Corporation was developed, accepted by the Russian CAA and approved by Order by the Director of Moscow ATM Office, State ATM Corporation as of 04.02.2015, the manual complying with ICAO SARPs (Annex 19, Doc 9859, Doc 4444) and defining provisions as to SMS objectives, establishment and functioning as well as structural departments functions and personnel duties as related to SMS. The Manual takes into account the requirements of FAR ATM including Chapter XII "Ensuring Flight Safety in ATM".

In accordance with Para 2, Article 24.1 of the Air Code the requirements on SMS development and implementation are approved by RF Governmental Resolution № 1215 as of 18.11.2014 and become effective in November 2015.

Since 01.03.2014 the Manual was subject to trial operation. Provisions on structural departments and job descriptions of personnel have been redesigned to comply with the Manual.

Based on the trial operation results the Manual was revised and underwent another approval of Rosaviatsiya and became effective since 01.12.2014 as per Enterprise Order № 595 as of 31.10.2014.

While the SMS was developed and implemented, the personnel were being trained on SMS. The training was conducted on the facilities of Air Navigation Institute Training Center base on a 40-hour training program "Safety and Quality Management Systems for Air Navigation Service".

In accordance with Order № 159 as of 25.02.2014 for Moscow ATM Center "On trial operation of the Air Navigation Service Safety Management Manual of State ATM Corporation" at Moscow ATM Center, Vnukovo ATC Center, the trial operation of the Manual was conducted from 01.03.2014 to 01.09.2014.

The Director of Moscow ATM Center approved as of 25.02.2014 an Action Plan on Implementation of Order № 50 of State ATM Corporation as of 04.02.2014, Implementation and Functioning of Air Navigation Service SMS, the objective of which plan was to integrate SMS into ATM and Radio Navigation Service of Vnukovo ATC Center.

By 20.10.2014 the following actions had been conducted in the framework of SMS¹⁹:

1. Statement of State ATM Corporation safety policy was communicated to personnel with written acknowledgement.

2. In accordance with the Safety Management Manual the following changes were introduced:

- to the provision on ATC Center on 10.04.2014, provision on Radio Navigation Service on 01.04.14, provision on Air Traffic Service on 10.04.2014;

- to job descriptions of Radio Navigation Service personnel on 03.02.2014 to 27.03.2014.

- to job descriptions of Head of Vnukovo ATC Center on 10.04.2014, head of Air Traffic Service on 10.04.2014, shift supervisor on 10.04.2014, chief ATC officer on 10.04.2014, chief shift ATC officer on 10.04.2014, instructor controller on 10.04.2014 and chief ground controller on 10.04.2014.

3. The Emergency Response Plan of ATM center was approved by acting director of Moscow ATM Center, State ATM Corporation on 17.05.2014.

4. The following was accomplished in terms of risk management:

Personnel of the Center were familiarized with the Safety Management Manual. Responsible persons for risk management were assigned (managers of safety action groups), a safety action group of ATM Center was formed, and responsible persons were assigned for entering and upgrading data in the safety database. The Action Plan on Implementation of Order № 50 of State ATM Corporation as of 04.02.2014 as applicable to Vnukovo ATC Center was accomplished.

The Directives functions of the safety database is used for personnel training based on the lessons learnt. The information in the safety database is considered by safety action groups' managers and communicated to personnel during Air Traffic Service and RNS briefings, and preventive actions are taken as required.

Safety is maintained through quality control of ATM processes based on the recorders readout data, monitoring of safety performance indicators of radio navigation, meteorological and aerodrome services as well as analysis of ATS and RNS personnel actions.

5. There were no voluntary reports on safety hazards.

6. The following persons have been assigned to operate the safety database:

- RNS - chief RNS engineer;

- ATS - head of Air Traffic Service, instructor controller of ATS;

¹⁹ The information has been provided by Vnukovo ATC Center

- Order № 287 for Moscow ATM Center as of 28.03.2014 assigned experts and safety action groups responsible for risk management, data entry, upgrading and maintaining information in the database;

- pertinent amendments were made to job descriptions of experts responsible for risk management in accordance with the Safety Management Manual;

- Emergency Response Plan was developed, coordinated and approved on 17.05.2014.

- voluntary reporting system was introduced;

- 24/7 monitoring of controller shifts was ensured using specific form of shift supervisor reports;

- the radio navigation service process is being monitored on a daily basis based on reports from controllers as to the navigation aids operation, both on-line and via the Navigation and Communication Aids Log, as well as via the Log of PIC reports on Landing and Navigation Aids of Vnukovo AP with records on corrective actions taken;

- navigation aids operations also monitored by the RNS management on a daily basis based on reports of chief shift engineers, Log of RNS shift engineer, line maintenance log of Tower shift engineer (mechanic).

The issue of introducing the airfield surveillance radar was discussed at the methodological council of the Center, amendments were introduced to controllers' working procedures, in-house and simulator training of controllers was conducted on the use of the radar.

In violation of Para 12.2.2 and 12.4 of FAR-293 as well as Chapter 4 of the Air Navigation Service Safety Management Manual of State ATM Corporation, no documented safety risk assessment upon introduction of a new surveillance system - airfield surveillance radar was provided to the investigation team.

2. ANALYSIS

2.1. Sequence of Events and Flight Description

On 20.10.2014 the crew of Falcon-50EX F-GLSA was conducting flight LEA 074P from Moscow Vnukovo to Paris Le Bourget. The takeoff weight was 35479 lb (16093 kg) with CG of 22.5% within the operational limitations as per the AFM.

The crew arrived on board at about 14:25²⁰.

At 15:22 before starting his duty, the driver of snowplow 3 underwent a medical check at the medical unit of Vnukovo AP, confirmed by a remark in roadmap № 53825 and duty release of the driver. A record of the medical check passed by the driver was made in the Log of pre-duty medical check of shift 3 drivers.

After passing the medical check the driver of snowplow 3 inspected his assigned vehicle SCHMIDT SUPRA-5001 garage number 377, signed its acceptance and provided it to the mechanic.

Note: *Extract from the interrogation of the snowplow 3 driver as of 21.10.2014:*

"Based on the medical check I was admitted fit for duty and returned to the room where I changed into the uniform and afterwards inspected my vehicle, Supra 5001, number 377 being assigned to me on that day. I signed accepting the vehicle as it was operative."

The aerodrome service mechanic made a final inspection of snowplow 3 and signed the roadmap stating the vehicle was operative.

Note: *Extract from the explanations of the aerodrome service mechanic as of 23.10.2014:*

"... I signed the roadmaps and inspected the technical condition of the vehicles. All instruments, including lights, beacons and radio transmitter were operative. After that (names of snowplow 1, 2 and 3 drivers) were supervised by the shift engineer..."

At 15:30 the aerodrome service shift duty was transferred from Shift 2 to Shift 3 in the aerodrome service supervisors' room. As the shift duty was transferred, the shift 3 supervisor was informed by the shift 2 supervisor on the aerodrome surface condition, works conducted by shift 2 and works to be done at the airfield.

²⁰ The Flight Data Recorder was engaged at 16:02.

Note: *Extract from the explanation of shift 2 supervisor as of 01.11.2014:*

"At approximately 19 h 30 min Moscow time on 20.10.2014 I arrived at the aerodrome service for the shift transfer. I was changed by the lead engineer - shift 3 supervisor (name). In the lead engineer room I informed (name) orally on the surface condition, airfield limitations, works performed by my shift and elements of the airfield requiring further works. As I was transferring that information I informed (shift supervisor's name) that my shift had cleaned surfaces and lights at TWY B8 and that there were snow banks left on edges of TWY B8 and RWY 13 that did not affect flight safety, but had to be removed as the air temperature could go below 0 degrees."

At 16:00 the lead engineer of airdrome service started his duty as shift 3 supervisor.

Note: *Extract from the interrogation of (name of shift supervisor) as of 21.10.2014:*

"On 20.10.2014 I started my duty at 20 h 00 min Moscow time."

At approximately 16:20 the airdrome service shift supervisor arrived at Airport Director on Duty to coordinate the amount and location of operations at the airfield. As the operations were coordinated, the Airport Director on Duty determined the following time of operations for shift 3 at RWY 1 in use: from 22:00 to 22:30 on 20.10.2014.

Note: *Extract from the interrogation of (name of shift supervisor) as of 21.10.2014:*

"At approximately 20 h 20 min Moscow time I came to Airport Director on Duty (name) to coordinate the airfield operations. Afterwards we coordinated the amount and location of operations."

Extract from the interrogation of the Airport Director on Duty (name) of 02.12.2014:

"Through the broadcast channel between the airport management and the shift supervisor of the Vnukovo ATC center shift supervisor... I said word-for-word to (name of shift supervisor): "from two till two thirty we are performing the active runway

periodic cleaning"²¹. I set a task for (name of the airdrome service shift supervisor) to perform the works from 2 o'clock on 21.10.14 of Moscow time till 02:30 on 21.10.2014 "

At 16:23 the instructor controller and at 16:39 the trainee controller passed medical check at Moscow ATM Center medical station of Vnukovo AP medical unit and were admitted to duty.

From 17:20:06 till 17:28:54 the ATC shift supervisor conducted the pre-duty briefing of ATC shift 3 in the Tower briefing room. The briefing was recorded on a tape recorder.

During the briefing, upon order of the ATC shift supervisor:

1. The chief shift controller assigned controllers to their working positions in the ATC room:

- departure ATC WP - instructor controller;
- departure ATS WP - controller 1;
- landing control WP - controller 2;
- approach control WP - controller 3.
- ground control WP Ground 1 - controller 4 and controller 5.

The management of controller change at respective working positions was determined under supervision of ATC shift supervisor and chief shift controller.

Note: *Extract from Readout 7 of the recording system at the briefing room 20.10.2014:*

«17:20:06 ATC shift supervisor. 20 minutes. Let's start the briefing. Shift 3. Personnel present. Medical checks passed. Certificates present. Floor is given to chief controller. Working position allocation".

"17:20:15 Chief shift controller. Departure control - (name of instructor controller, name of controller 1), Landing - (name of controller 2), Approach - (name of controller 3), Ground - (name of controller 4 and name of controller 5), change of controllers supervised by the shift supervisor and chief controller".

2. The engineer-meteorologist stated the weather forecast from 17:00 on 20.10.2014 till 04:00 on 21.10.2014 and actual weather at Moscow Vnukovo, Moscow Sheremetyevo, Moscow Domodedovo and Ramenskoye airdromes.

3. Airdrome service engineer (via the speakerphone) reported on the airdrome condition.

4. Radio navigation service engineer reported on the operability of the navigation aids.

²¹ It is confirmed by the radio exchange transcript, although the verbatim text is different.

5. Electrical and lighting service engineer reported on the operability of the electrical and lighting aids.

6. The ATC shift supervisor informed the shift on the flight schedule for the shift, runway heading in use, category, taxiing patterns, shift peculiarities with regard to actual weather conditions and safety measures. Then he conducted flight rehearsal and ordered the shift to take duties at their respective working positions.

Note: *The ATC shift supervisor warned the shift personnel that judging by the weather forecast, transfer to low visibility procedure might be possible. In fact this procedure was not put in place.*

At 17:33:54 the instructor controller took duty at Departure ATC WP, recording that in the Log of duty transfer and takeoff and landing time accounting at Departure ATC WP and reported that via the speakerphone. The trainee controller also took her duty.

At 17:35 the ground controllers took duty at Ground 1 WP²²:

- controller 4 took duty at Ground 1 ATC²³;

- controller 5 took duty at Ground 1 V²⁴;

which they recorded in the Log of Ground 1 Duty Transfer.

At 17:36:50 controller 1 took duty at Departure ATS WP, recording that in the Log of duty transfer and takeoff and landing time accounting at Departure ATS WP and reported that via the speakerphone.

From 17:37 the air traffic control in the departure control area was provided from two working positions, Departure Control ATC and Departure Control ATS.

At 18:00 controller 1 transferred duty at Departure ATS WP to the chief shift controller (relief change), which was recorded in the Log of duty transfer and takeoff and landing time accounting at Departure ATS WP.

At approximately 18:40 the aerodrome service shift 3 supervisor conducted an inspection of the airfield and made a pertinent record in the Log of Airfield Condition.

²² The ground controllers were working at Ground 1 WP (in the end of 2011 Ground 1 and Ground 2 sectors were joined).

²³ Ground 1 ATC - ground controller providing ATC.

²⁴ Ground 1 V - ground controller providing coordination.

Note: *Extract from the interrogation of (name of airdrome service shift supervisor) as of 21.10.2014:*
"At 20 h 40 min Moscow time I inspected the RWYs and TWYs using the airdrome service Ford Ranger."

The Airport Director on Duty confirmed the technical condition of the airdrome, making the following record in the Log of Airfield Condition: "Airfield suitable for flights (signed)".

The ATC shift supervisor was familiarized with the technical condition of the airdrome, making the following record in the Log of Airfield Condition: "Familiarized (signed)".

At approximately 18:45 airdrome service shift 3 supervisor and ATC shift supervisor coordinated airfield operations while in the Tower.

Note: *Extract from the interrogation of (name of aerodrome service shift supervisor) as of 21.10.2014:*
"After inspecting the RWY I brought the Log of Airfield Inspections to be signed by the Airport Director on Duty and ATC shift supervisor. I reported to the ATC shift supervisor (name) on the planned operations."

Extract from the interrogation of (name of ATC shift supervisor) as of 31.10.2014:

"Within 23 hrs to 24 hrs Moscow time on 20.10.2014 the snowplows were to be operating at taxiway Bravo Eight. TWY B8 is located at a safe distance from RWY 06/24 and the snowplow operations were not a safety concern.

These operations were coordinated with me at about 20 h 45 min Moscow time²⁵ by the airdrome service engineer (name) who came to coordinate these operations to my working position in the Tower.

At RWY 06/24²⁶ the snowplows under supervision of (name) were to be operating from 02 h 00 min to 02 h 30 min Moscow time on October 21, 2014."

Thus as per the evidence of ATC shift supervisor while airfield operations were coordinated, the operation of airdrome vehicles at threshold 01 of RWY 2 (closed for takeoffs and landings) was neither planned nor coordinated.

²⁵ The investigation team believes that the time was mistaken, as actually the events in question occurred two hours earlier.

²⁶ Note of investigation team: the runway in use for takeoffs and landings

Most probably, the ATC shift supervisor informed the duty on shift that the airdrome vehicles would work on Taxiway 8 that is confirmed with the interrogation of controller 4 (occupying the working position of the ground controller): "The ATC shift supervisor informed of the work of airdrome vehicles at B8, but I cannot remember for sure".

However the controller 4 could not give an unambiguous answer to this question.

At the same time while being interrogated on 22.10.2014 the driver of snowplow 1 evidenced the following: "According to the schedule of work we were to clean the Alpha-4 taxiway (hereinafter referred to as TWY A4), then Bravo-8 (hereinafter referred to as TWY B8) TWY A7²⁷, RWY 2 ...», that is according to his words, the works were planned at RWY 2 as well, not only TWY B8, as the ATC shift supervisor evidenced.

The evidence of the airport director on duty contains contradictory information related to the coordination of works at RWY 2.

Note: *Extract from the interrogation record (airport director on duty's name) of 02.12.2014:*

"On 19.10.2014 there was heavy snowfall. On 20.10.2014 there was no snow. The airdrome service shift supervisor... informed me that he had to plow the snow off the inactive runway, the taxiways, including TWY 8..."

However further on during the same interrogation the airport director on duty evidenced:

"I am not aware, in what manner the lead engineer (name of the airdrome service supervisor) made the decision on the works carry out at TWY Bravo-8... (The name of the airdrome shift supervisor) reported to me only that he was going to carry out works at the Bravo-8 taxiway, he did not report to me of any other works."

The issue on the coordination of works carry out at the airfield and the evidence of the airdrome service shift supervisor are unclear. According to his evidence: "I told the airport director on duty and the ATC shift supervisor: "we will work at the airdrome"... I meant the airfield cleaning. In no logbook or any other document was the direction and order of the works carry out at this shift recorded."

At approximately 19:00 airdrome service shift 3 supervisor gathered drivers of snowplows 1, 2 and 3 in the airdrome service engineer room and conducted an oral briefing. During the briefing he determined the location of each driver in the vehicle team during the

²⁷ The driver might have meant A8 taxiway (investigation team footnote).

operations, informed them on the plan and amount of operations, communication channels and ordered the drivers to prepare the vehicles for operations. All vehicles were to gather at TWY A3.

Note: *Extract from the interrogation of (name of aerodrome service shift supervisor) as of 21.10.2014:*

"... I gathered the snowplow drivers in my room (engineer room) and informed them on the operations plan. There were three drivers - (three names). I informed the drivers on the plan and location of operations, amount of work and communication channel.

In the course of the briefing it was determined that first to move on the Frosya snowplow garage number 360 was (name), following him was to be (name) on Supra snowplow (I don't remember the number) and following him (name) on Supra snowplow garage number 377. I was to accompany the team and monitor the operations on a Ford ranger driven by (name). As per the established procedure, all vehicles gathered at TWY Alpha 3 (designated as A3 on the chart).

Extract from the interrogation of the snowplow 3 driver as of 21.10.2014:

"Yes, I was briefed by the lead engineer (name), all of the three snowplow drivers. He told us drivers that we were to gather before the TWY crossing near Alpha 3. He determined the amount of work, meaning we were to operate on the right side on the way from Vnukovo-2, which is closer to RWY 1. Further the route could be changed on the way."

Thus the investigation team generally concludes that the aerodrome service staff, ATC personnel and the airport director on duty did not have uniform understanding of the work scope and the location of the snow-removal works at the airfield. It is only the works time at the active RWY 2 and works on TWY B8 that is confirmed by all the mentioned specialists.

At 19:01 chief shift controller transferred duty at Departure ATS WP to controller 1, which was recorded in the Log of duty transfer and takeoff and landing time accounting at Departure ATS WP.

At 19:05 two working positions were united upon order of the ATC shift supervisor: Departure ATS WP and ATC WP, which was recorded by the Departure ATS controller in the Log of duty transfer and takeoff and landing time accounting at Departure ATC WP.

From 19:05 on aircraft takeoffs and airfield traffic was controlled from the Departure ATC WP by the trainee controller under supervision of the instructor controller.

At 19:10, upon order of the ATC shift supervisor, the functions of Ground 1 ATC and Ground 1 V were joined, controller 4 recorded that in the Log of Ground 1 Duty Transfer.

At approximately 19:15 three vehicles driven by snowplow drivers 1, 2 and 3 as well as the airdrome service shift supervisor car were at the ramp in front of TWY A3.

At 19:19:22 the airdrome service shift supervisor requested clearance from the departure ATC to cross RWY 1 from TWY A3 to A4: "Upon clearance Sixth plus three vehicles from Alpha 3 to Alpha 4".

Note: *The call sign «Sixth» was that of the airdrome service shift supervisor.*

At 19:25:37, after the vehicles had been cleared to cross and crossed RWY 1, the aerodrome service shift supervisor reported the departure controller on crossing and upon instruction changed to communication channel "Ground" with ground controller: "First, Sixth. Runway in use vacated". "Sixth, First. Roger. Runway in use vacated. At Alpha 4 contact Ground 120.45".

From 19:23:03 to 19:26:20 the aircrew being at stand, listened to ATIS (information Papa as of 19:16): "*Vnukovo ATIS. Information Papa. One nine one six. ILS approach Runway zero six. With wet snow, status one millimeter. Braking action good, zero five. Transition level six zero. Apron, taxiway snowed and slippery. Taxiway Alpha one three, taxiway Charlie four are out of operation. Taxiway Mike three out of operation between taxiway Alpha two and taxiway Alpha five runway two out of operation between taxiway Mike two and runway twenty four. Bird flocks envisaged at aerodrome terminal area and final.*

Present weather. Surface wind one two zero degrees three meters per second. Visibility five five zero meters. RVR one thousand four hundred. Light drizzle, fog. Vertical visibility seven zero meters, temperature one, dew point one, QFE niner seven one hectopascals, seven two eight millimeters. Warning: moderate icing in cloud. Trend: temporary visibility two hundred meters, fog, cloud, overcast three zero meters. Acknowledge Information Papa.

At 19:26:02 the ATC shift supervisor reported to the Ground controller on the start of operations at TWY A4 and B8 and received confirmation: "*Sixth plus three vehicles er... Alpha 4 Bravo 8 treatment*". "*Sixth, cleared*".

After crossing RWY 1 via TWY A4 the first was snowplow 1 number 360, the second was snowplow 2 number 378, the third was snowplow 3 number 377, the separation between the vehicles was 10-15 meters (Figure 55).

The airdrome service shift supervisor accompanied the team on the left and monitored the snowplow operations.

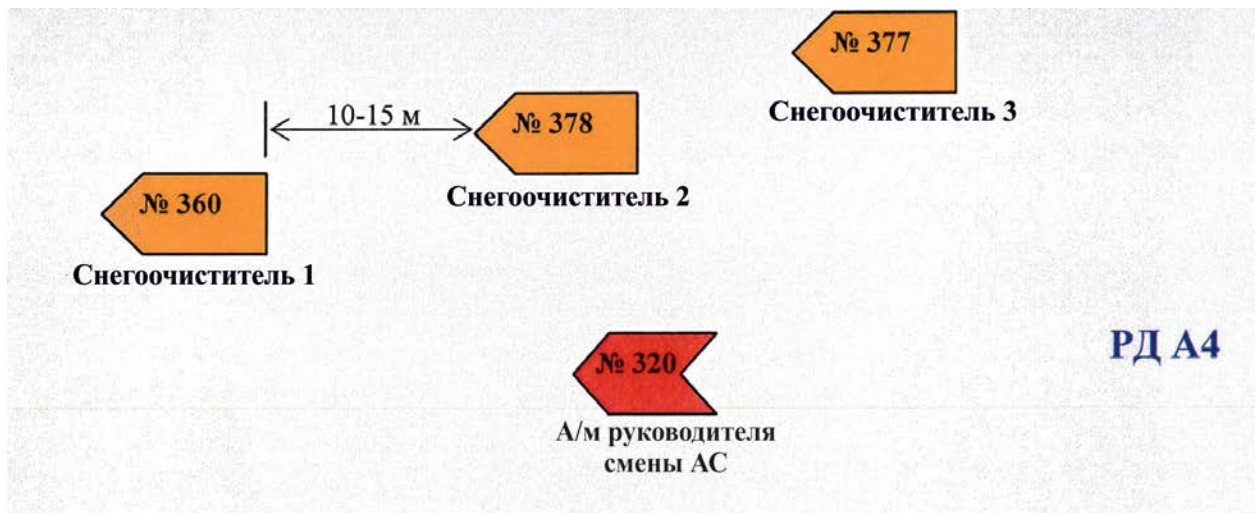

Figure 55. Location of snowplows during operations at RWY A4

After moving from TWY A4 to TWY B8 there was a failure of snowplow 2 (rotor blade was bent), which was reported by the applicable driver to the airdrome service shift supervisor.

Note: *Extract from the witness interrogation record (name of the snowplow 2 driver) of 22.10.2014: «Immediately on turn from A4 to B8 I hitched the water drain grid and had the rotor blade bent, of which I straightforwardly informed (name of the airdrome service shift supervisor) via cell phone.»*

Extract from the explanation of driver (name) of snowplow 2 as of 23.10.2014:

"On the corner of A4 and B8 the rotor blade was bent. I reported that to the lead shift engineer (name), and he told me to go to the airdrome service to have the vehicle repaired."

Extract from the interrogation of (name of aerodrome service shift supervisor) as of 21.10.2014:

"In the course of the operations, after occupying TWY B8 a snowplow driven by (name) was broken. As I was informed by the latter (either via radio or telephone, I don't remember now), a rotor blade was bent. Due to that I decided to send (name) to the airdrome service to have the vehicle repaired."

The airdrome service shift supervisor decided to send the vehicle to the airdrome service and accompanied snowplow 2 till the crossing of RWY 1. Meanwhile the other two snowplows continued operations at TWY B8, moving along the right side of the TWY towards TWY A8.

At 19:33:13 the airdrome service shift supervisor requested clearance from the departure controller to cross RWY 1: "Sixth plus one vehicle, Alpha 4 to Alpha 3 to cross". At 19:33:47, after accompanying snowplow 2 until the start of TWY A3 turning back and going to TWY A4, the airdrome shift supervisor reported to the departure controller on vacating RWY 1: "First, Sixth plus one vehicle have vacated runway in use".

At 19:33:51 the departure controller instructed the airdrome shift supervisor to contact Ground controller: "Sixth, First. Roger. Vacated, to Alpha and... Alpha 3 contact Ground". However, the airdrome service shift supervisor did not contact the ground controller.

A bit earlier, at 19:33:25, the crew contacted Delivery and requested clearance to depart: "*Good evening, Sir, LEA zero seven four Papa, Falcon five-zero, stand three Bravo, information Papa, requesting clearance*", and the controller asked to hold. At 19:38:26 Delivery contacted the crew requesting to report when they are ready for departure. The crew responded that they were awaiting the passengers, and Delivery asked to inform when they were ready.

After return of the airdrome service shift supervisor, his car and two snowplows (1 and 3) were moving along the right side of TWY B8 (see airdrome chart, Figure 27 and Figure 28), after that turned right to TWY A8 (Figure 56 and Figure 27). Having reached the marking of the holding point at the runway on TWY A8 turned left, then turned into the opposite direction. Then they completed operations at TWY A8, came to TWY B8 and approached the holding point marking on TWY B8 before the inoperative RWY 2.

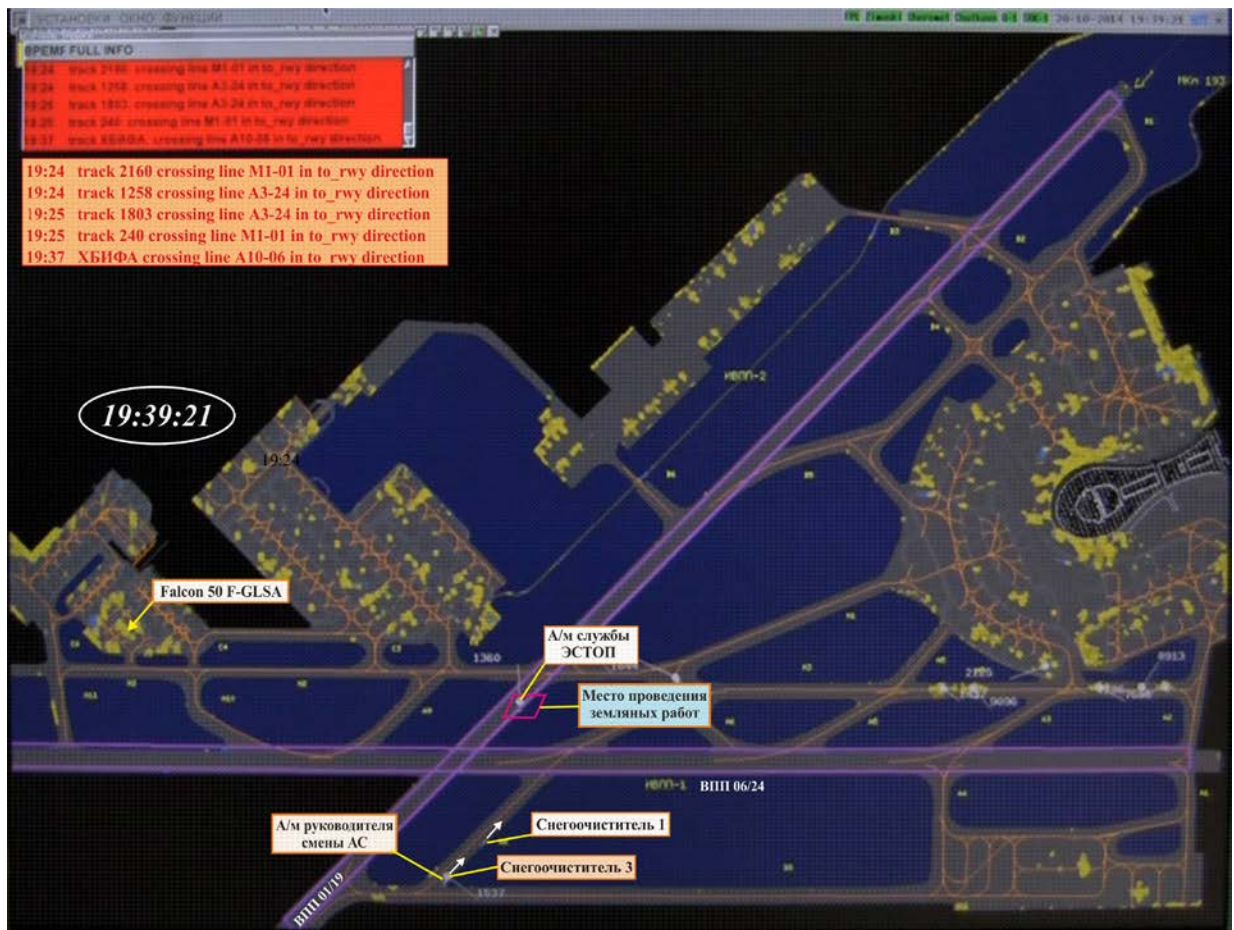

Figure 56. Location of objects at airdrome Vnukovo as viewed from the ground controller screen at 19:39:21

At 19:43 the airdrome service shift supervisor car and snowplows 1 and 3 without notification or clearance of the air traffic service drove from TWY B8 to the inoperative RWY 2 (Figure 57).



Figure 57. Location of objects at airdrome Vnukovo as viewed from the ground controller screen at 19:43:27

While operating on the right side of RWY 2, driver of snowplow 1 detected a fragment (basement) of the runway light (Figure 58). The driver reported the runway light fragment detection via radio to the airdrome service shift supervisor. The path of vehicles movement before the runway light was detected is shown in Figure 59.

Note: *Extract from the interrogation of (name of aerodrome service shift supervisor) as of 21.10.2014:*

"...I was radioed by (name) telling that while leaving TWY B8 for RWY 2, he (name) detected fragments of the runway light on the right edge of the runway."



Figure 58. Fragment of runway light (basement)



Figure 59. Vehicle path (shown in dotted line) after snowplow 2 was broken and before snowplow 1 detected the fragment of runway light

The airdrome shift supervisor arrived at the site where the light fragment had been detected and called the lighting service expert via the service mobile phone for inspection.

Note: *Extract from the interrogation of (name of aerodrome service shift supervisor) as of 21.10.2014:*

"Being near the runway light I called electrician engineers to inspect the runway light via the service mobile phone (I don't remember the number)".

Engineers of the lighting service of Vnukovo AP set off for the site where the light fragment were detected on a service GAZ-330273, garage number 74, from the site where earthwork were conducted by TransEngineering Limited (Figure 59).

Note:

On 20.10.2014 near RWY 2 between the big and small crossing experts of TransEngineering Limited conducted scheduled earthwork setting cables of lighting systems (Figure 59 and Figure 60). Experts of the electrical and lighting service of Vnukovo AP supervised the course of the earthwork.

The indicated works had started on 17.10.2014 and had earlier been conducted at daytime, of which the respective NOTAM had been issued: NOTAM of 16.10.2014

«From 04:00 till 15:00 on 17.10.2014 till 20.10.2014 daily:

1. Runway 01/19 is closed for aircraft takeoff and landing operations.

2. The section of Runway 01/19 from runway 06/24 as far as taxiway M2 is closed for aircraft taxi and towing operations».

The works on 20.10.2014 were planned to be carried out at nighttime, the respective NOTAM being issued as well:

NOTAM of 20.10.2014

«From 15:00 20.10.2014 till 04:00 21.10.2014:

1. Runway 01/19 is closed for aircraft takeoff and landing operations.

2. The section of runway 01/19 from runway 06/24 as far as taxiway M2 is closed for aircraft taxi and towing operations»

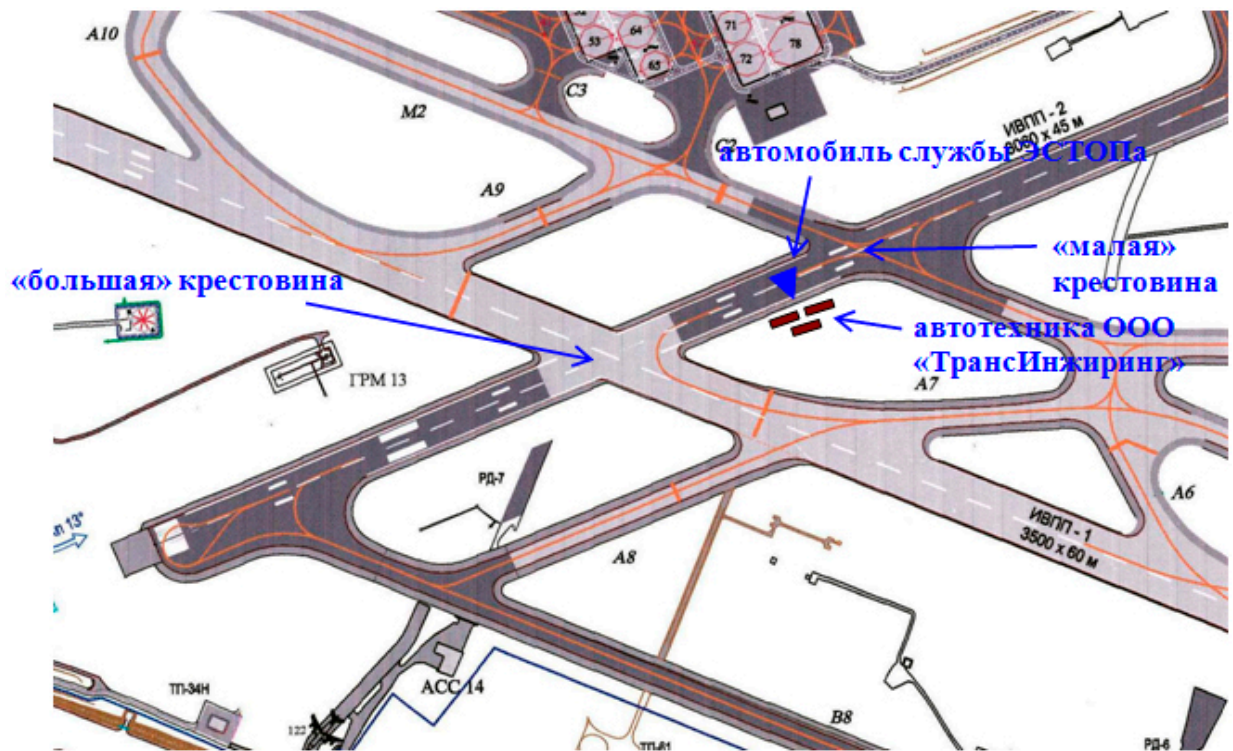

Figure 60. Location of vehicles at the site of earthwork

At 19:48:10 the crew reported to Delivery they were ready for the flight: «Hello again, Sir, LEA zero-seven-four Papa is (fully) ready». The location of objects at Vnukovo airdrome at that time is shown in Figure 61.

At 19:48:29 Delivery advised the departure conditions: «Zero-seven-four Papa you are cleared for (proceed) to destination Lima Foxtrot Papa Bravo, expect Uniform Mike euh zero-six Delta departure, initially climb six hundred meters, departure frequency one-two-six decimal zero, squawk one-five-two-one».



Figure 61. Location of objects at airdrome Vnukovo as viewed from the ground controller screen at 19:48:10

Note: Airport Paris Le Bourget, ICAO code: LFPB. UM 06 D – departure pattern from Vnukovo airdrome.

The crew confirmed receiving the information and then Delivery advised them to contact Vnukovo Ground at 120.45 MHz.

At 19:48:49 electrical and lighting service engineers requested clearance from the departure controller to cross RWY 1 from the area of the small crossing: "*Electrical 74, request clearance to cross from RWY 19 to RWY 01*". The departure controller cleared: "*74, First, cleared to cross runway in use via runway 19*".

At 19:49:35 the electrical and lighting service experts on a car crossed RWY 1 and approached the standing snowplow 1 and the airdrome service shift supervisor car.

At 19:49:48 the crew requested ground controller clearance for engine startup: "*Hello Ground, LEA zero-seven-four Papa, Falcon five-zero, stand three Bravo, request start up*". (Figure 62 and Figure 63). The location of objects at Vnukovo airdrome at that time is shown in Figure 64.

At 19:49:53 the chief of electrical and lighting service informed the ground controller about being at RWY 01: "*Ground, Electrical 74 at RWY 01*", and the ground controller requested clarification: "*So, what site are you at?*" The chief of the electrical and lighting service informed the controller: "*The site - with Sixth, near Bravo 8*".

After cleared for the engine startup, the crew starting at 19:50:35 started up sequentially the second, third and first engines (Figure 62).

After the engine startup the flap/slat handle was set to position 2, corresponding to the extended slats and flaps 20 (takeoff configuration).

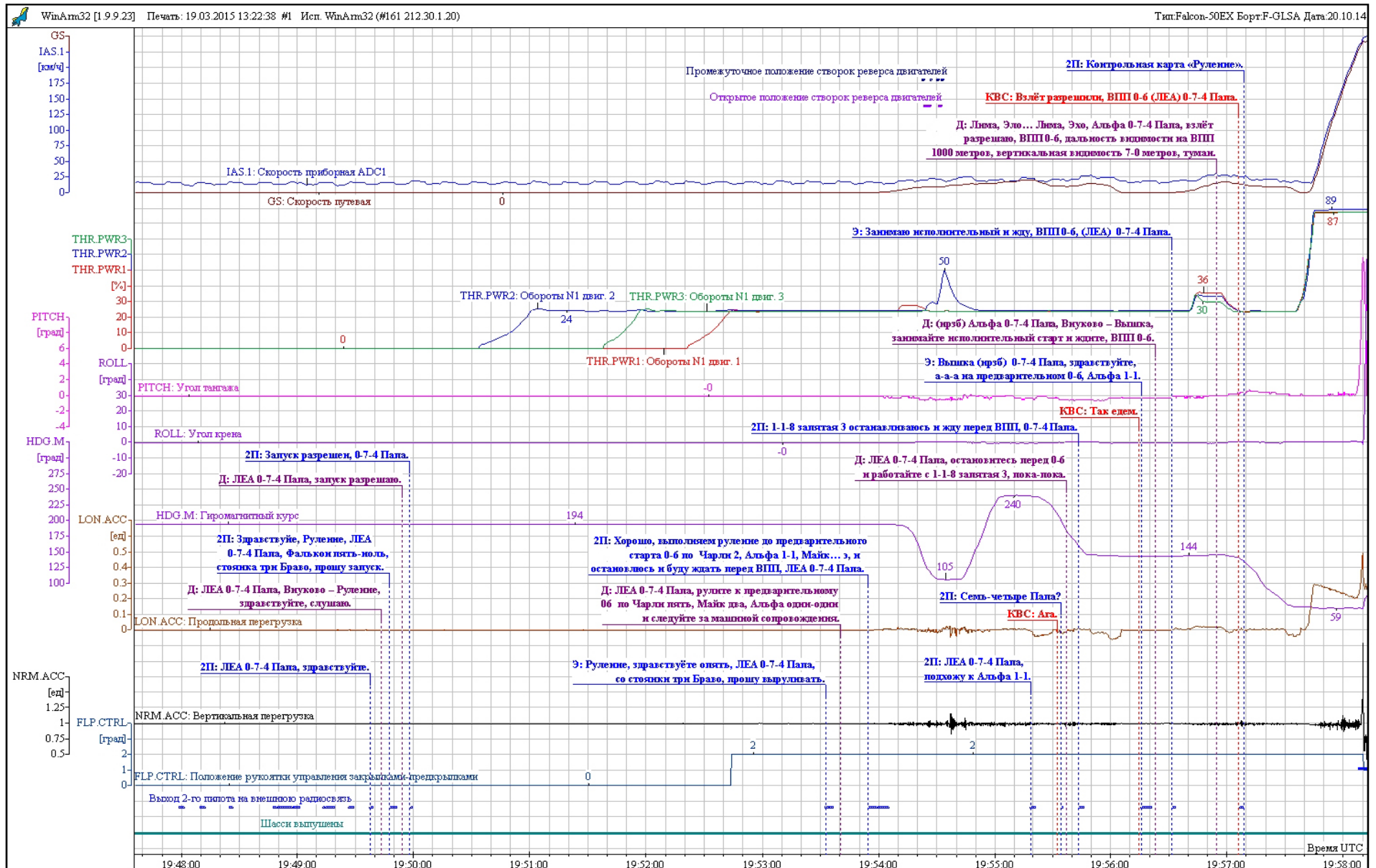

Figure 62. Flight parameters during takeoff of Falcon 50EX F-GLSA at Vnukovo AP on 20.10.2014

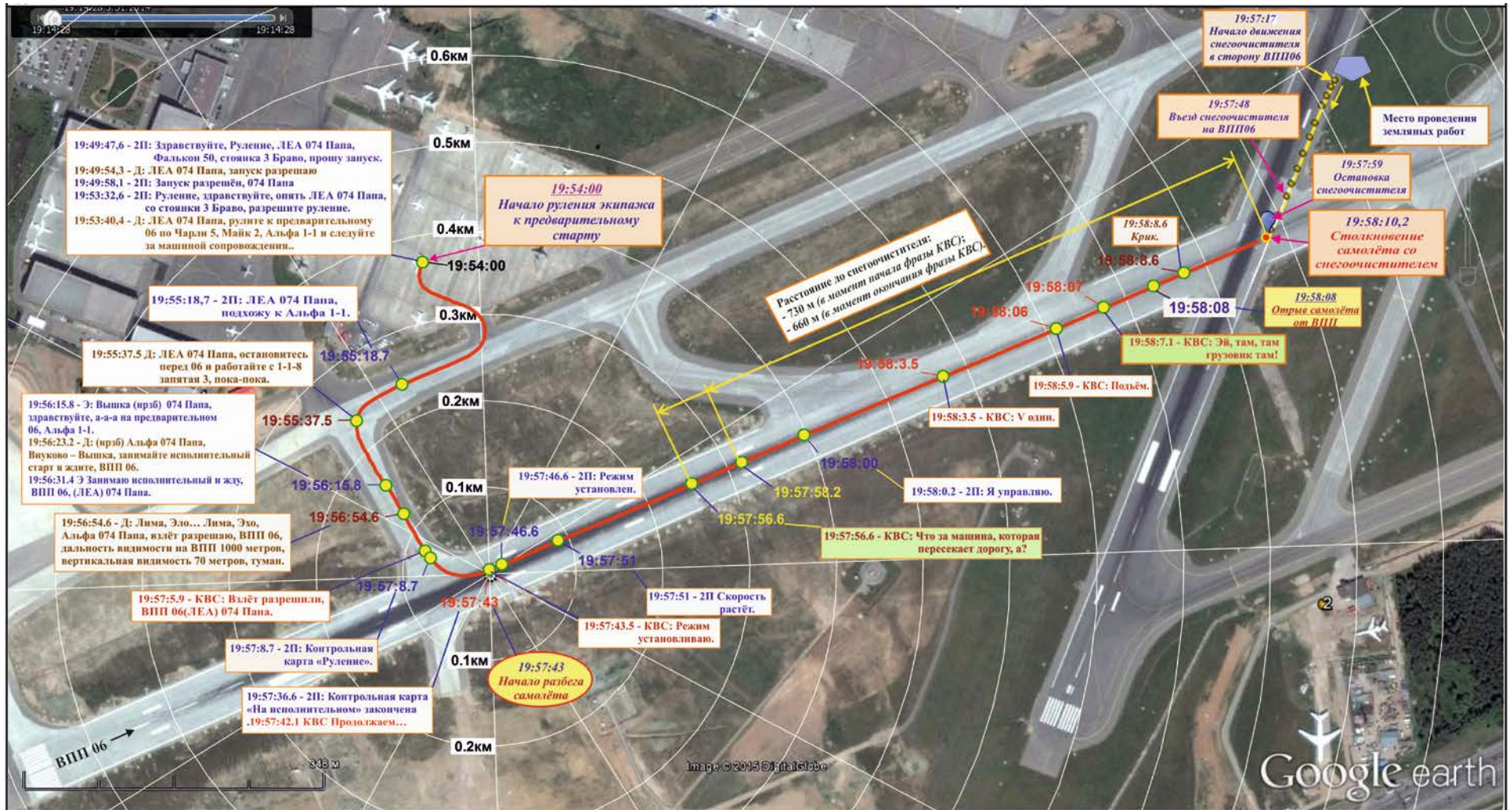

Figure 63. Path of Falcon 50EX F-GLSA at Vnukovo AP on 20.10.2014

As the electrical and lighting service engineers loaded the light fragment into their car they determined that all lights on that site were operative and lit. On the opposite side of RWY 2, closer to threshold 01, the engineers detected absence of runway edge light.

Note: *Extract from the explanation of electrical and lighting service engineer (name) as of 23.10.2014:*

"Having loaded that basement of the runway edge light into the car (Gazel, № M434 ET 177RUS) number 74, while turning to the opposite side of RWY 2 we noticed the absence of a runway edge light on the opposite side, closer to threshold 13 degrees..."

Extract from witness interrogation record (name of electrical and lighting service engineer) of 22.10.2014:

«In this case we were to draw up a report of a light damage on-site, call for flight safety inspector that was working within that shift. This report had to be signed by the person that had drawn up a report (either myself, or (name of another electrical and lighting service specialist), by (name of the airdrome service) – as a representative of airdrome service, by flight safety inspector. Further on this report was to be approved by the airport director on duty. Then this report was to be transferred to the "Stop" center (name). I planned to draw up this report later as at that moment I was occupied with the performance monitoring over the Trans-Engineering subcontractor. This report had never been drawn up because of the accident situation that followed.

At 19:53:12 the electrical and lighting service car started moving to the unlit light at RWY 2, while snowplow 1 started moving towards the big crossing. Snowplow 3 and airdrome service shift supervisor's car remained where they were.

At 19:53:34 snowplow 3 and airdrome service shift supervisor's car also started moving towards the big crossing.

At 19:53:33 without reaching the big crossing the airdrome vehicles started turning left. The vehicles traffic pattern is shown in Figure 65.

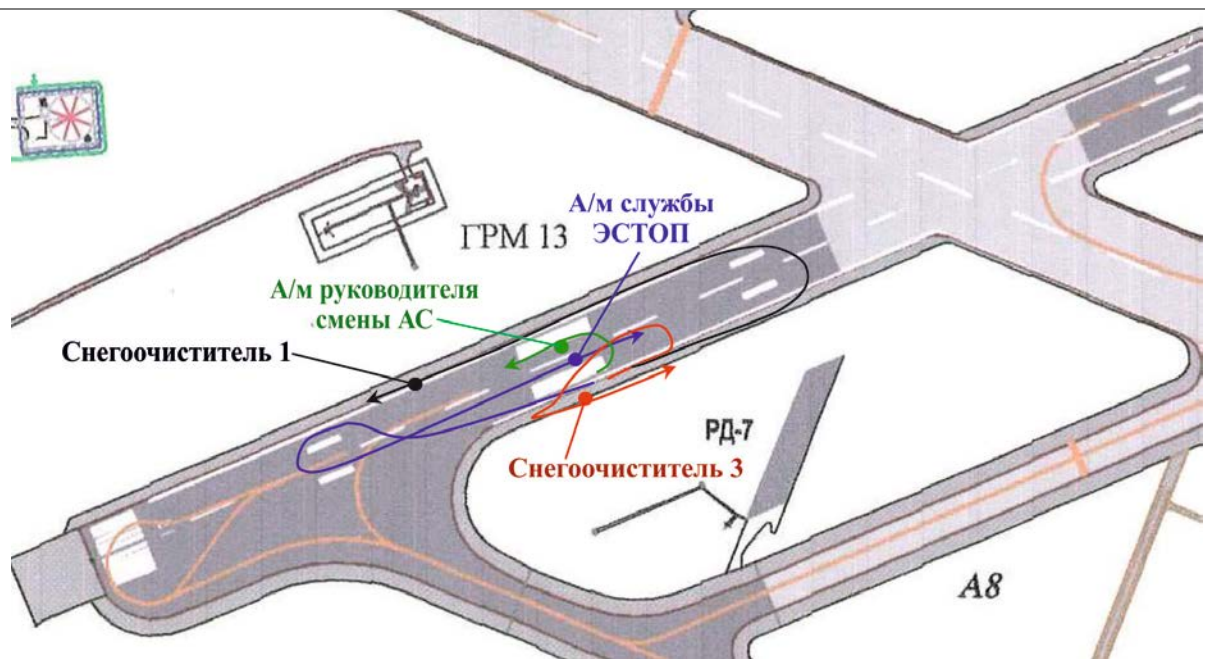

Figure 65. Paths of airdrome service vehicles and electrical and lighting service car

At 19:53:33 the crew requested the ground control clearance to taxi to holding position: "Ground, hello again, LEA zero-seven-four Papa, from stand three Bravo, request taxi" and received it at 19:53:40: "LEA zero-seven-four Papa taxi to holding point zero-six via Charlie five, Mike two, Alfa one-one and follow "Follow me".

Note: Stand three Bravo - stand 3B, Charlie 5 - TWY C5, Mike 2 - TWY M2, Alfa 11 - TWY A11.

As they were cleared to taxi the crew at 19:53:54 responded to the ground controller: "O'key, taxing holding point zero-six via Charlie two, Alfa one-one, Mike... eh-eh-eh, and hold short of the Runway, LEA zero-seven-four Papa" and at 19:54:00 started taxiing to the holding position (Figure 62 and Figure 63). The crew taxied following the follow-me car.

By the time the aircraft started taxiing, snowplows 1, 3 and the airdrome service shift supervisors car were at RWY 2 between TWY B8 and big crossing. The electrical and lighting service engineers, after inspecting the lighting equipment near threshold of RWY 2, set off on their Gazel car towards the site of earthwork.

At 19:54:00 the driver of towing vehicle garage number 63 of Russia Special Flight Squadron requested the ground controller to clear them for TWY A4: "Ground, 63 - 63, go ahead. - Er... request clearance for Alpha 4 to cross runway in use to Alpha 3".

At 19:54:10 the ground controller cleared the towing vehicle number 63 of Russia Special Flight Squadron for TWY A4 and further contact with departure controller: "63, cleared for Alpha 4, contact Departure."

At 19:54:12 the chief of electrical and lighting service requested from the departure controller clearance to cross RWY 1 in use: "Request crossing RWY in use from 01 to 19" and at 19:54:17 was cleared ("Electrical 74, First. Cleared to cross runway in use via runway 01").

The electrical and lighting service car, while moving towards the big crossing, passed between the airdrome service shift supervisors car and standing snowplow 3 (Figure 65 and Figure 66). At 19:54:22, 10 seconds after the electrical and lighting service car had passed snowplow 3 started moving towards the big crossing next of the electrical and lighting service car (Figure 65 and Figure 67). Snowplow 1 started moving along the right edge of RWY 2 heading south and the airdrome service shift supervisor's car followed it.

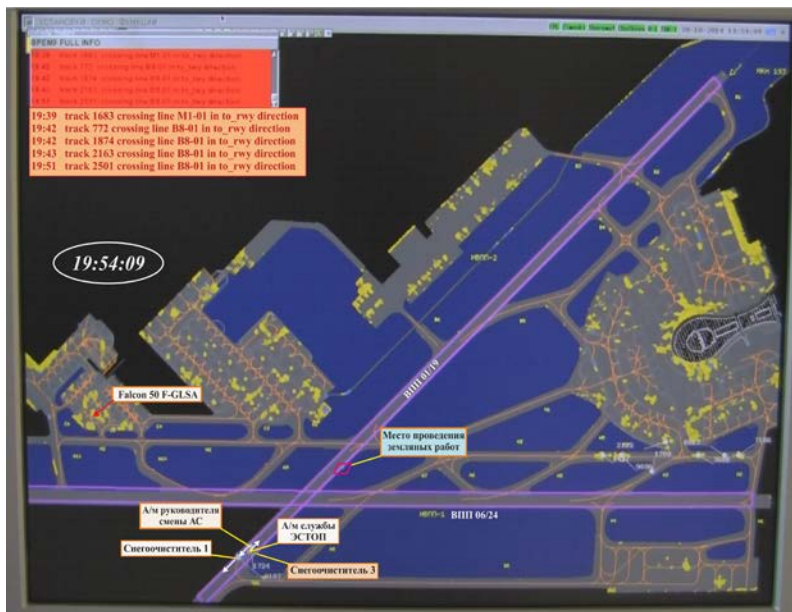

Figure 66. Location of objects at airdrome Vnukovo as viewed from the ground controller screen at 19:54:09

Meanwhile the crew was checking the operation of reverse thrust²⁸, which is confirmed by the recorded signals: "Reverse thrust doors intermediate position" and "Reverse thrust doors open" as well as changing operation mode of Engine № 2 (Figure 62).

At 19:54:35 the driver of towing vehicle 63 of Russia Special Flight Squadron requested from the departure controller clearance to cross RWY 1 from TWY A4 to TWY A3: "First, towing 63. - 63, First, go ahead. - Request crossing RWY in use from Alpha 4 to Alpha 3".

²⁸ At the Falcon-50EX aircraft the thrust reverser is installed at the second (middle) engine only

At 19:54:45 the departure controller cleared the towing vehicle 63 to cross RWY 1 from TWY A4 to TWY A3: "63, cleared to cross RWY in use from Alpha 4 to Alpha 3".

At 19:54:55, after crossing RWY 1 in use, the chief of electrical and lighting service reported to the departure controller: "*Electrical 74. Runway in use vacated*" and then the departure controller instructed them to contact Ground Control. Then the electrical and lighting service car reached the site of earthwork.

At 19:55:08, the chief of electrical and lighting service reported to the ground controller: "*Ground, Electrical 74. At small crossing*". During the exchange, the chief of electrical and lighting service clarified the location of electrical and lighting service experts and their further actions: "*Well, between Mike 2 and runway in use at working position*", "*Standing. Standing. Still working.*"

At 19:55:19 the aircrew informed the ground controller on approaching TWY A11: "*LEA zero-seven-four Papa, approaching Alpha one-one*".

At 19:55:24 the driver of towing vehicle 63 of Russia Special Flight Squadron reported to the departure controller on vacating RWY 1: "First, 63. Runway in use vacated for Alpha 3. Thank you."

Snowplow 3 proceeded with its movement in the direction of RWY 1 (Figure 68), at 19:55:32 it stopped before the RWY, at 19:55:40 crossed RWY 1 without request or clearance from the departure controller and continued moving towards the small crossing.



Figure 67. Location of objects at airdrome Vnukovo as viewed from the ground controller screen at 19:54:22



Figure 68. Location of objects at airdrome Vnukovo as viewed from the ground controller screen at 19:55:20

At 19:55:38 the departure controller instructed the crew: "*LEA zero-seven-four Papa, hold short of zero-six and contact one-one-eight decimal three, bye, bye*".

At 19:55:44 the crew responded to the ground controller: "*One-one-eight decimal three, hold short of the runway, zero-seven-four Papa*".

At 19:56:16 the crew reported the departure controller on reaching holding point: "*Tower (illeg) zero-seven-four Papa, hallo, a-a-a... holding point zero-six Alpha one-one*" (Figure 62 and Figure 63).

After crossing RWY 1 snowplow 3 continued moving northwards (towards the small crossing) along the right edge of RWY 2.

The airdrome service shift supervisor, according to his explanation, when noticing the absence of snowplow 3 rapidly set off along RWY 2 towards the big crossing on his car. The airdrome service shift supervisor did not make any reports to controllers.

At 19:56:23 the crew was instructed by the departure controller to line up: "*(illeg) Alfa zero seven four Papa, Vnukovo - Tower, line up and wait runway zero six*" (Figure 62 and Figure 63). The location of objects at Vnukovo airdrome at that time is shown in Figure 69.



Figure 69. Location of objects at airdrome Vnukovo as viewed from the ground controller screen at 19:56:23

At 19:56:31 the crew informed the departure controller on taxiing for line up: *Line up and wait, runway zero six, (LEA) zero seven four Papa*" and started moving.

At 19:56:44... 19:56:45 snowplow 3 stopped near vehicles at the site of earthwork (Figure 70 and Figure 71).

Note: *Extract from the explanation of electrical and lighting service engineer (name) as of 23.10.2014:*

"As I parked the Gazel service car, garage number 74, state number M 434 ET 177RUS across RWY 2 beyond the beacon line with the transmitter on, I left the car and noticed an approaching snowplow with headlights and strobe light on, throwing snow onto the runway edge. Then it stopped 7 to 10 meters away from our service car, remained still for about 15-20 seconds and then started moving backwards. I did not see its further movements."

Meanwhile, the airdrome service shift supervisor stopped at RWY 2, about 140 m left before the crossing (Figure 70).

Note: *Extract from the interrogation of (name of aerodrome service shift supervisor) as of 31.10.2014:*

"As I heard the sound of the aircraft engine and radio signal (on hold) I stopped the car without reaching the crossing, at a safe distance. Then we started reverse movement and saw a blast of fire."

At 19:56:55 while moving to line up the crew was cleared for takeoff by the departure controller and received weather information: *"Lima Elo... Lima Echo Alfa zero-seven-four Papa, cleared for takeoff, runway zero-six, RVR one thousand meters, vertical visibility seven zero meters, fog».*

At the time of the takeoff clearance there were no obstacles on RWY 1 as per the airfield surveillance and control subsystem A3000 data (Figure 72). Snowplow 3 and electrical and lighting service personnel were at the site of earthwork, snowplow 1 near TWY B8, while the airdrome service shift supervisor's car was standing at RWY 2, approximately 140 m away from the crossing. There were no vehicles moving towards the runway in use.

At 19:57:06 during taxiing the crew confirmed the departure controller's clearance for takeoff: *"Cleared for takeoff, runway zero-six, LEA zero-seven-four Papa"* and after 3 seconds (at 19:57:09) and started accomplishing the During Taxi checklist.

Meanwhile the airdrome service shift supervisor started moving backwards towards threshold 01 of RWY 2 (Figure 73).

After completing the During Taxi checklist the crew, while still taxiing, started reading the Line-up checklist. Approximately 11 seconds after the crew had conformed the takeoff clearance (at 19:57:17) the airfield surveillance and control subsystem A3000 recorded start of the snowplow 3 movement (without track number) along the left edge of RWY 2 towards RWY 1 in use (Figure 73).

At 19:57:37 the FO reported to the PIC on completing the Line up checklist: "*Line up check list complete*". By the time the crew had completed the Line-up checklist the aircraft lined up along RWY 1 centerline with takeoff heading.

After a short stop of the aircraft at RWY 1 the crew initiated takeoff by increasing thrust and at 19:57:43 approximately 590 m from threshold 06 of RWY 1 started the takeoff roll (Figure 75). Meanwhile snowplow 3 continued moving towards RWY 1 at a speed of approximately 20 km/h (Figure 74 and Figure 75). There was still no track number of snowplow 3.

In the course of the takeoff roll snowplow 3, at 19:57:48, at a speed of approximately 20 km/h, without the request and without being cleared by the departure controller, started crossing RWY 1 (Figure 76). By that time the airfield surveillance and control subsystem A3000 had assigned track number 2228 to snowplow 3 and it was already identified with that number at controllers' working positions.

At 19:57:49, after the start of the takeoff roll, snowplow 3 having been identified as track 2228, with the RIM mode activated (see Section 1.8.2.1) a Pre-Alert was shown on the ATC shift supervisor's position followed by an Alert a second later. The ATC shift supervisor's monitor (if radar information was being displayed) should have shown respective messages (see below for details). The RIM mode was deactivated on the working positions of the Ground and Departure controllers.



Figure 71. Snowplow 3 stopping at 23:56:45 (19:56:45 UTC) near the earthwork site



Figure 72. Location of objects at airrome Vnukovo as viewed from the departure controller screen at 19:56:55



Figure 73. Location of objects at airdrome Vnukovo as viewed from the departure controller screen at 19:57:17

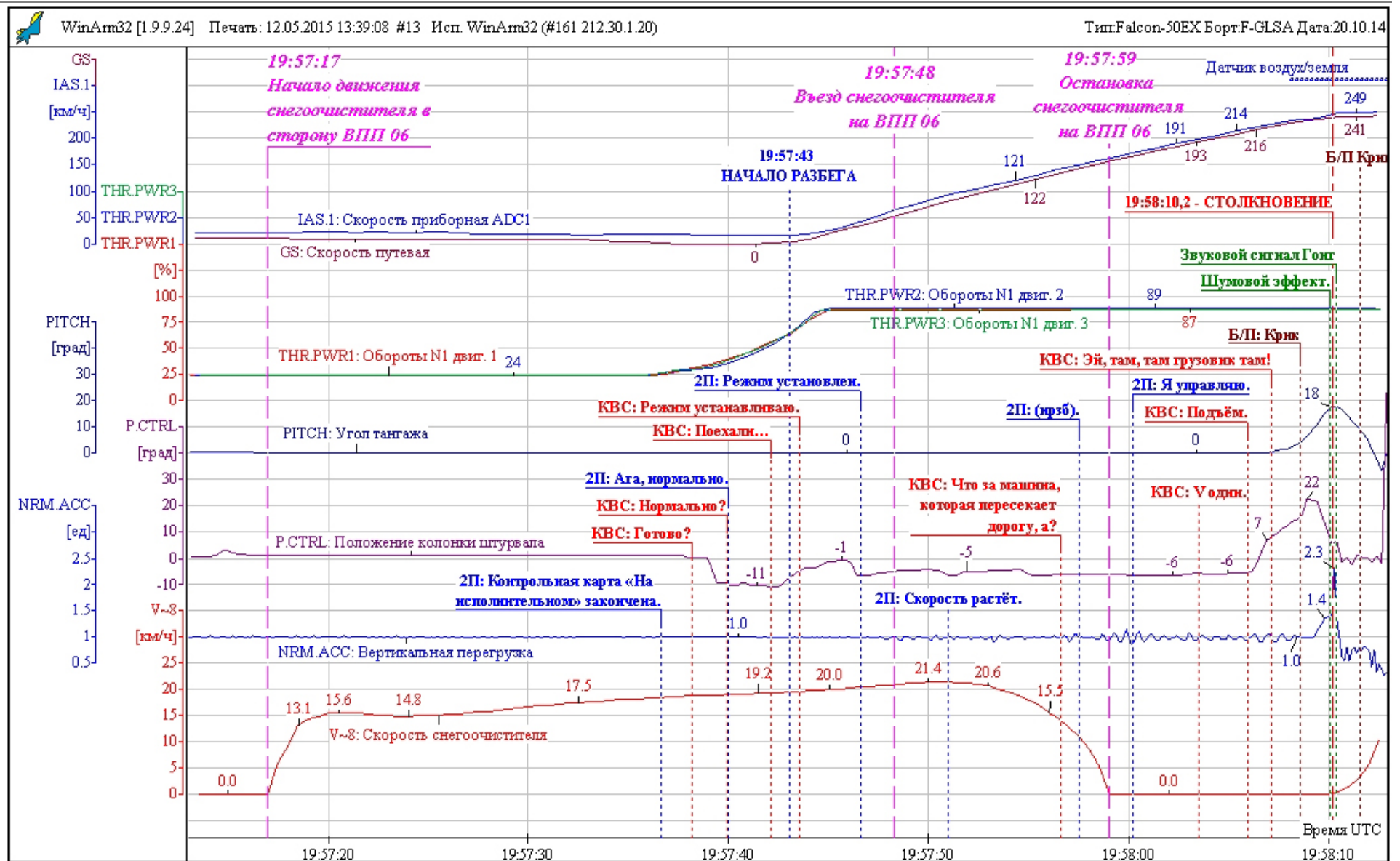

Figure 74. Flight parameters during takeoff of Falcon 50EX F-GLSA at Vnukovo AP on 20.10.2014 and speed of snowplow 3 movement from earthwork site to RWY 1

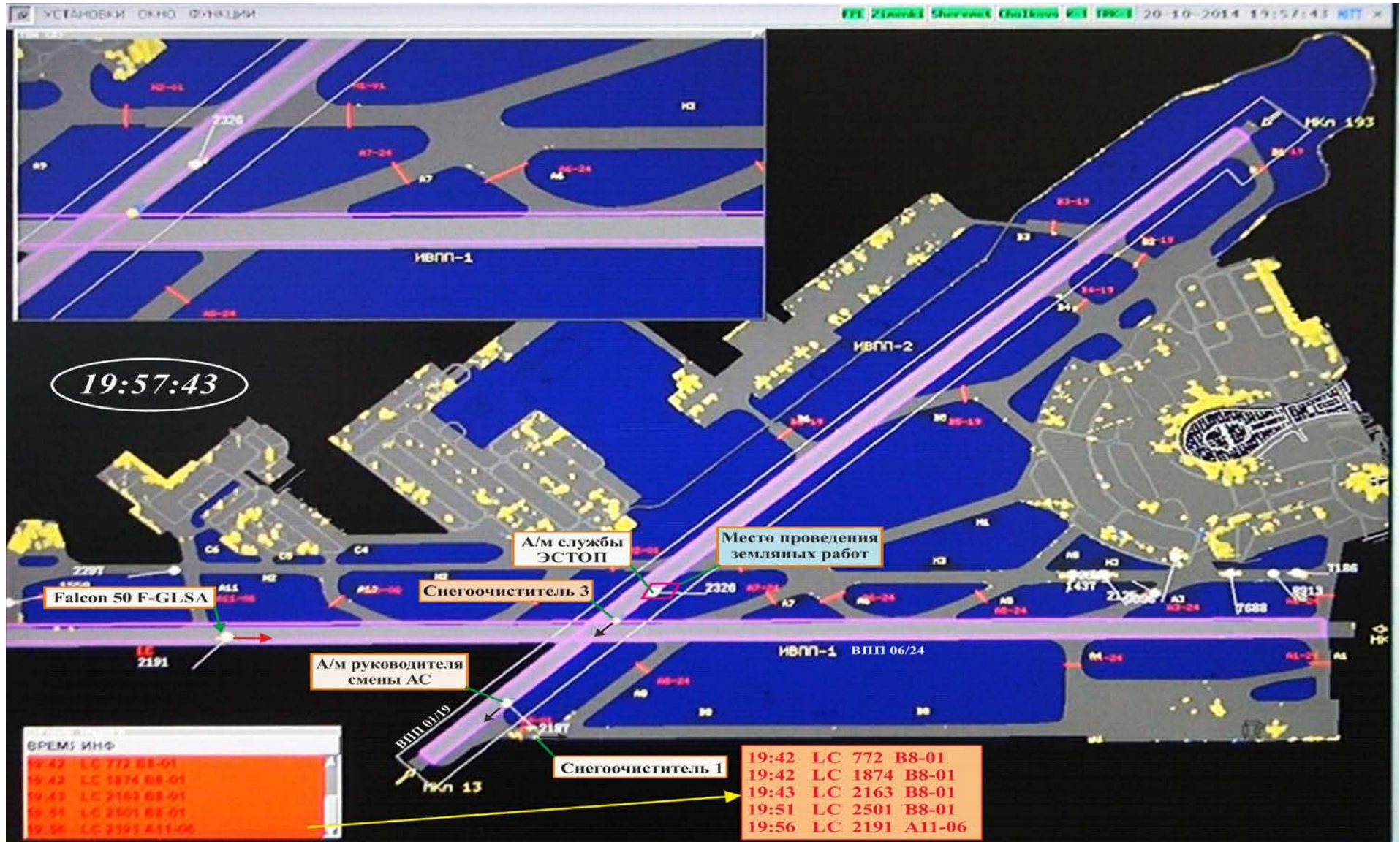

Figure 75. Location of objects at airrome Vnukovo as viewed from the departure controller screen at 19:57:43

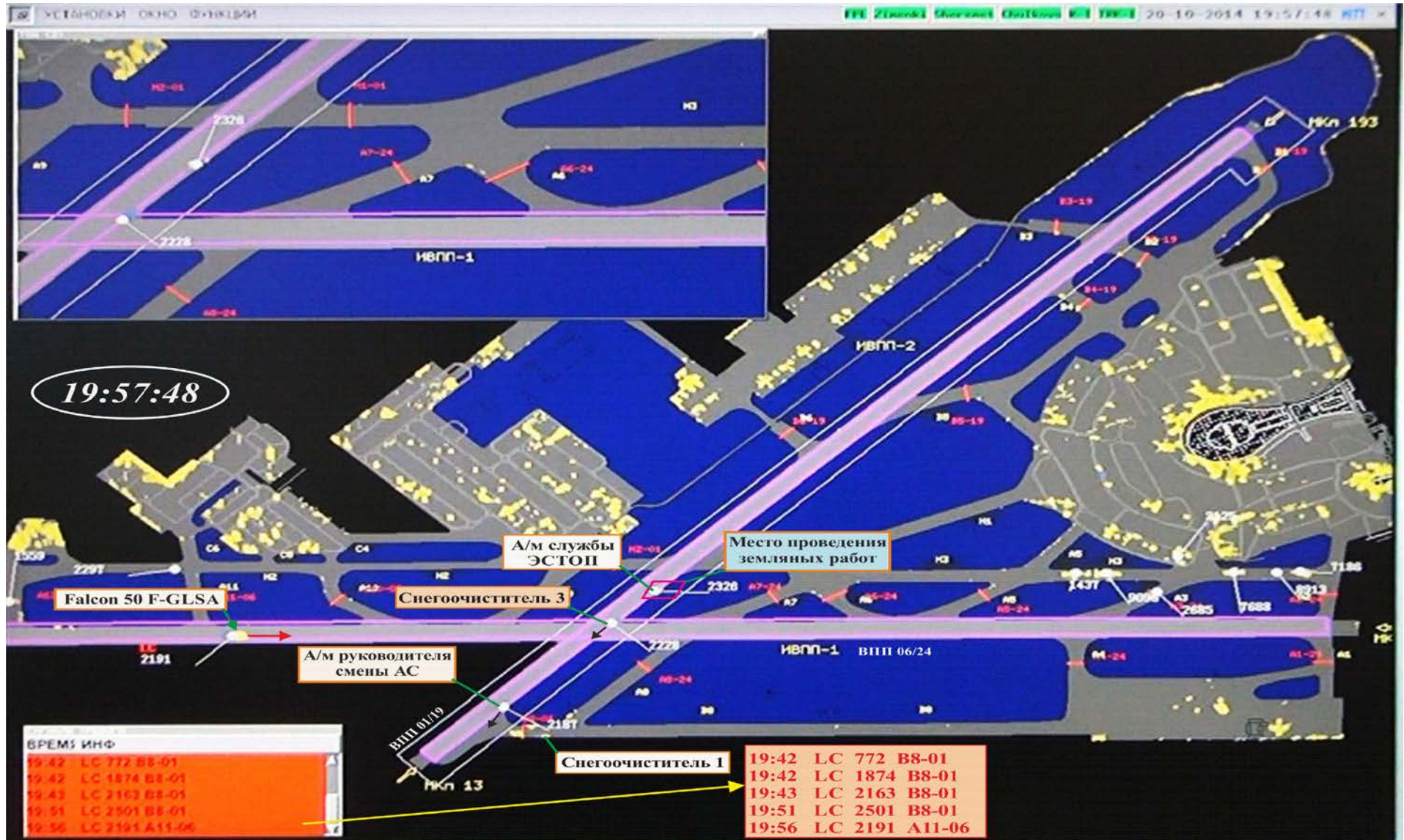

Figure 76. Location of objects at airdrome Vnukovo as viewed from the departure controller screen at 19:57:48

At 19:57:57 (14 seconds after the start of the takeoff roll) the PIC saw an object that he identified as a car, confirmed by his phrase: "*C'est quoi la bagnole qui croise la route eh?*" ("*What's the car crossing the road, eh?*") (Figures 77 to 79).

At 19:57:59 snowplow 3 passing a bit (5-6 meters) of RWY 1 centerline stopped near the big crossing, at about 1570 m from threshold 06 of RWY 1 (Figure 80).

Based on the records of two surveillance cameras installed near Checkpoint 4 it was determined that strobe lights and headlights of snowplow 3 were constantly on (Figure 81).

At 19:58:00, after reaching the speed of 80 knots the crew exercised transfer of control from the PIC to the FO. The FO, being the PF, in accordance with the SOP uttered: «*My control*».

At 19:58:04 at a speed of approximately 110 kt (204 km/h) the PIC called out reaching decision speed «*V one*», and then at 118 kt (218 km/h) reported rotation speed: «*Rotate*» and then the FO started pulling up the control column (Figure 77 and Figure 78).

At 19:58:07 at 123 kt (227 km/h), approximately 210 m before snowplow 3 the PIC shouted: «*Eh beh y-a, y-a un camion là!*» ("*Hey there's, there's a truck there!*") (Figure 78 and Figure 82).

At 19:58:08 at 127 kt (235 km/h) the aircraft after rolling for 845 m lifted off. The distance from the snowplow was approximately 145 m.

The pitch rate before the liftoff was almost the same as in the previous flight (Figure 83). After that PIC's phrase and aircraft liftoff the FDR recorded an additional abrupt nose up control column deflection. These actions is an evidence that the flying FO must have reacted to the PIC's words. As a result of such pilot actions the local aircraft AOA increased to 22-24 degrees.

Then the control column was pushed from 22 degrees to 5 degrees within about 0.75 sec. This could have been caused by the will of the pilot to avoid exceeding the critical AOA.

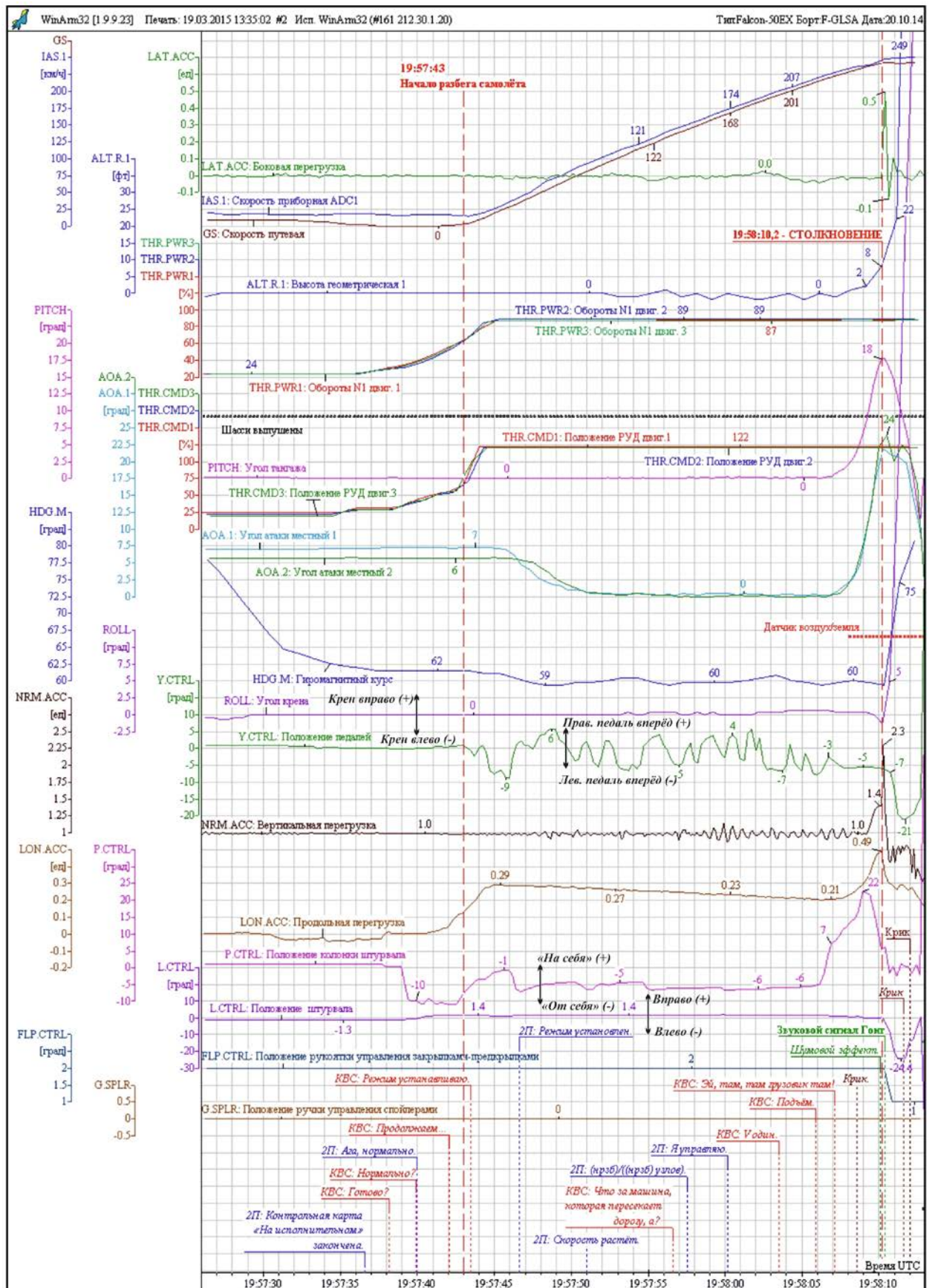

Figure 77. Flight parameters during takeoff of Falcon 50EX F-GLSA at Vnukovo AP on 20.10.2014

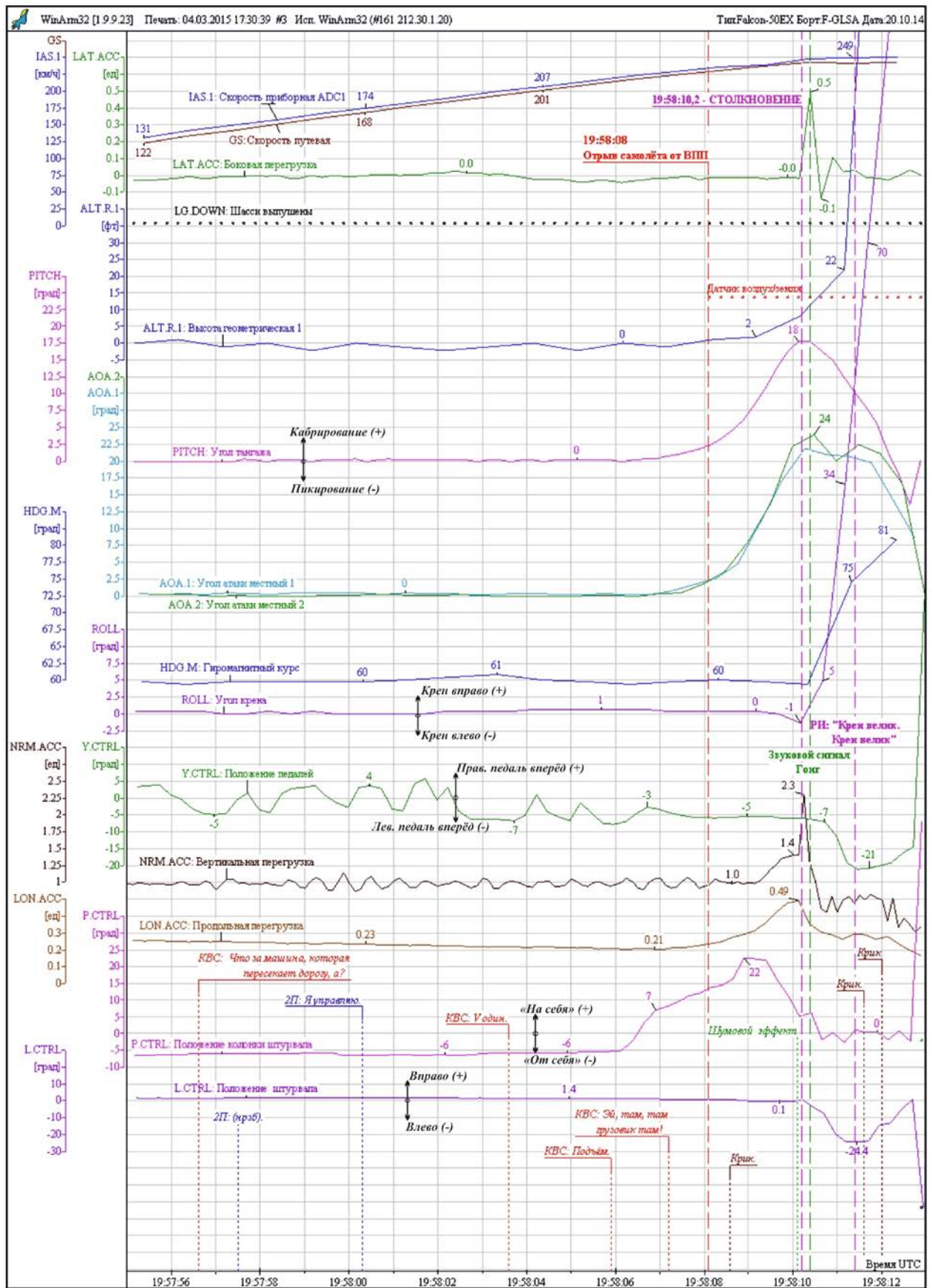

Figure 78. Flight parameters during takeoff of Falcon 50EX F-GLSA at Vnukovo AP on 20.10.2014

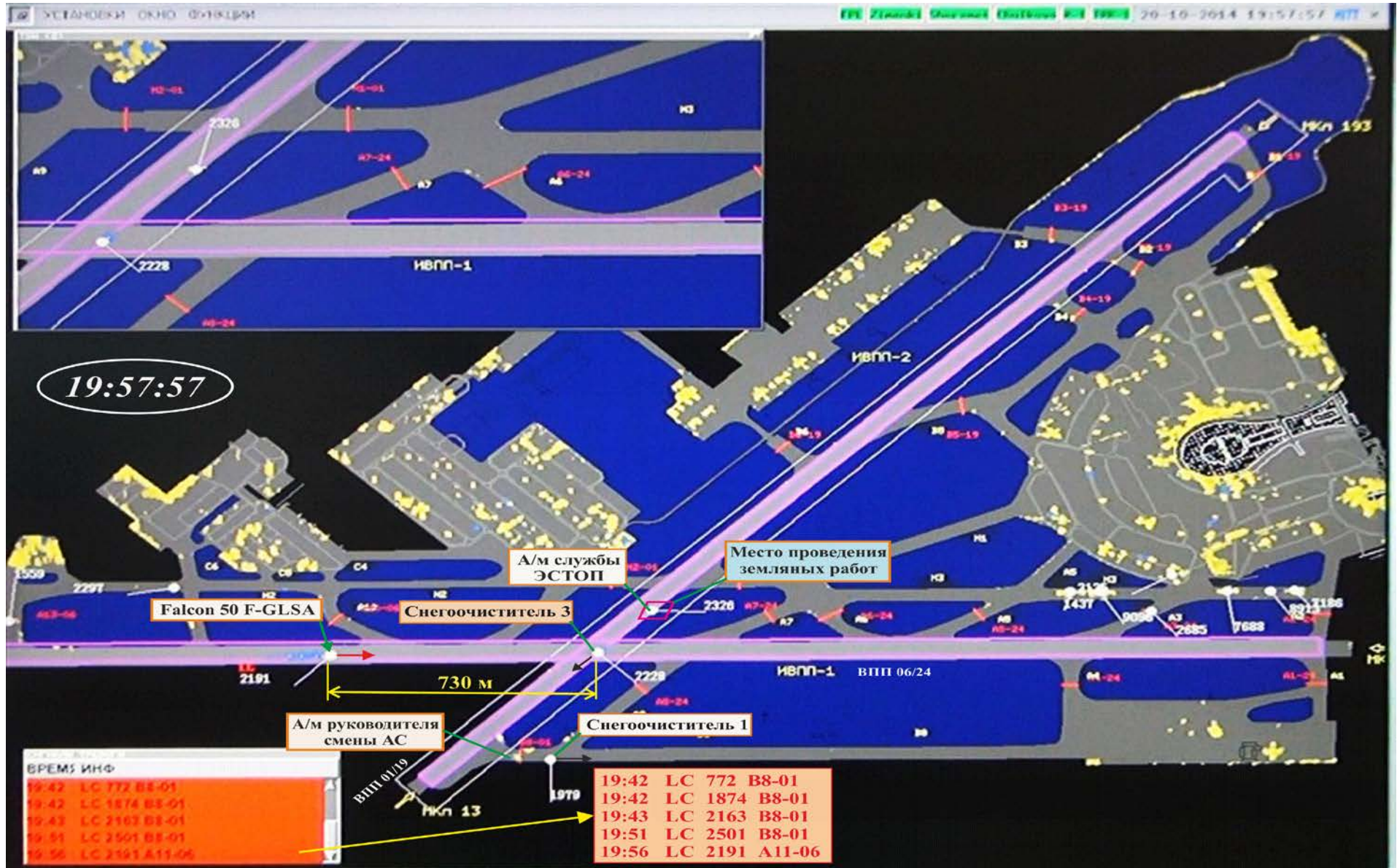

Figure 79. Location of objects at airrome Vnukovo as viewed from the departure controller screen at 19:57:57



Figure 80. Location of objects at airdrome Vnukovo as viewed from the departure controller screen at 19:57:59



Figure 81. Snowplow 3 stopping at 23:57:59 (19:57:59 UTC) at RWY 06 crossing



Figure 82. Location of objects at airdrome Vnukovo as viewed from the departure controller screen at 19:58:07

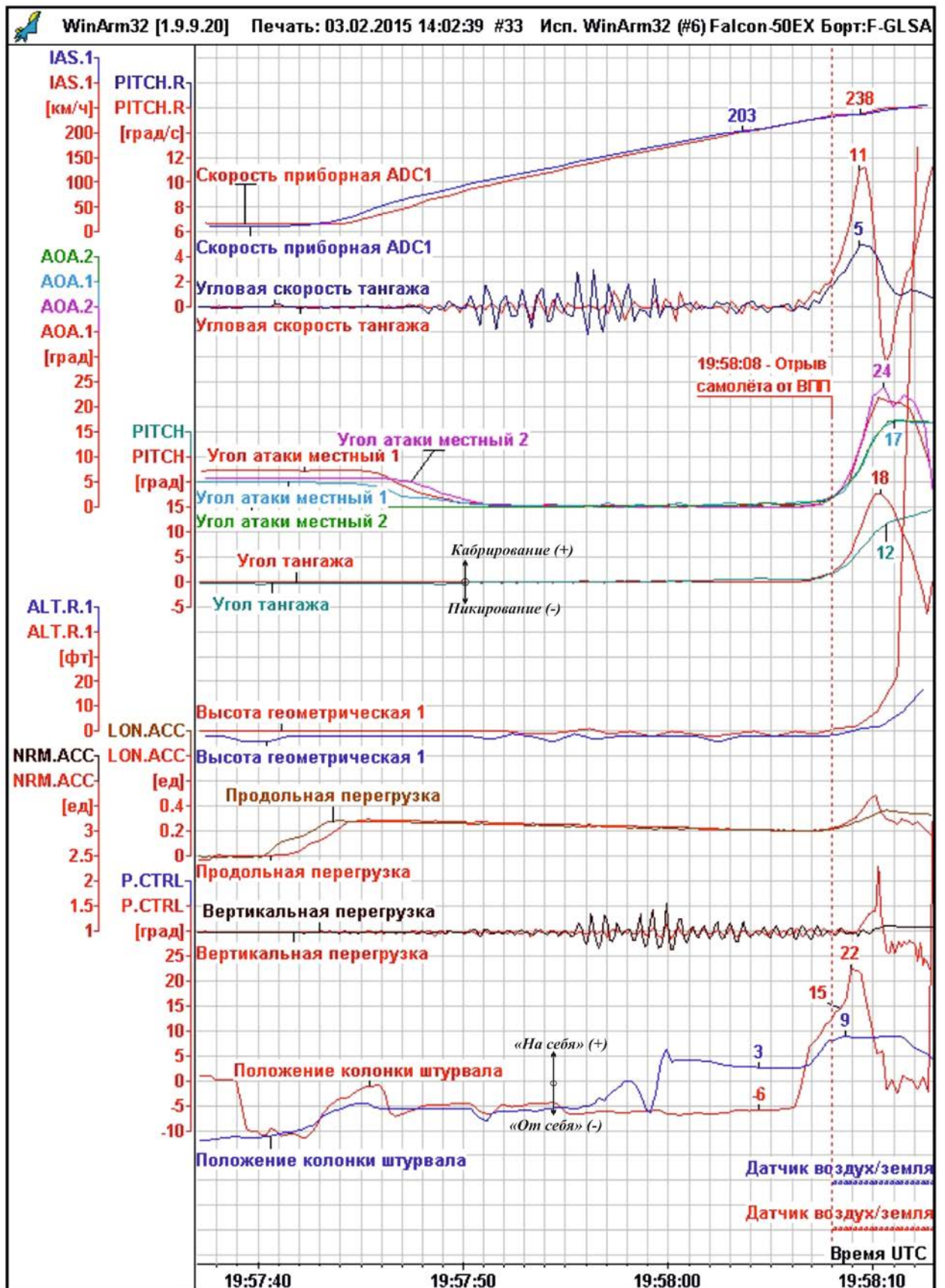

Figure 83. Comparison of flight parameters change during takeoff of Falcon 50EX F-GLSA at Vnukovo AP on 20.10.2014 with the respective parameters of the previous takeoff (shown in red are parameters of the flight on 20.10.2014)

The collision occurred at 19:58:10 (Figure 77, Figure 78 and Figure 86) which is confirmed by the flight recorder data: noise as the aircraft structure was destroyed, as well as abrupt increase of vertical and lateral loads reaching as much as 2.3 g and 0.5 g respectively. The aircraft collided with snowplow 3, its right wing hitting the cab roof and snow evacuation nozzle while its RH landing gear hit the aft hood at a height of 1.8 m (Figure 84 and Figure 85).

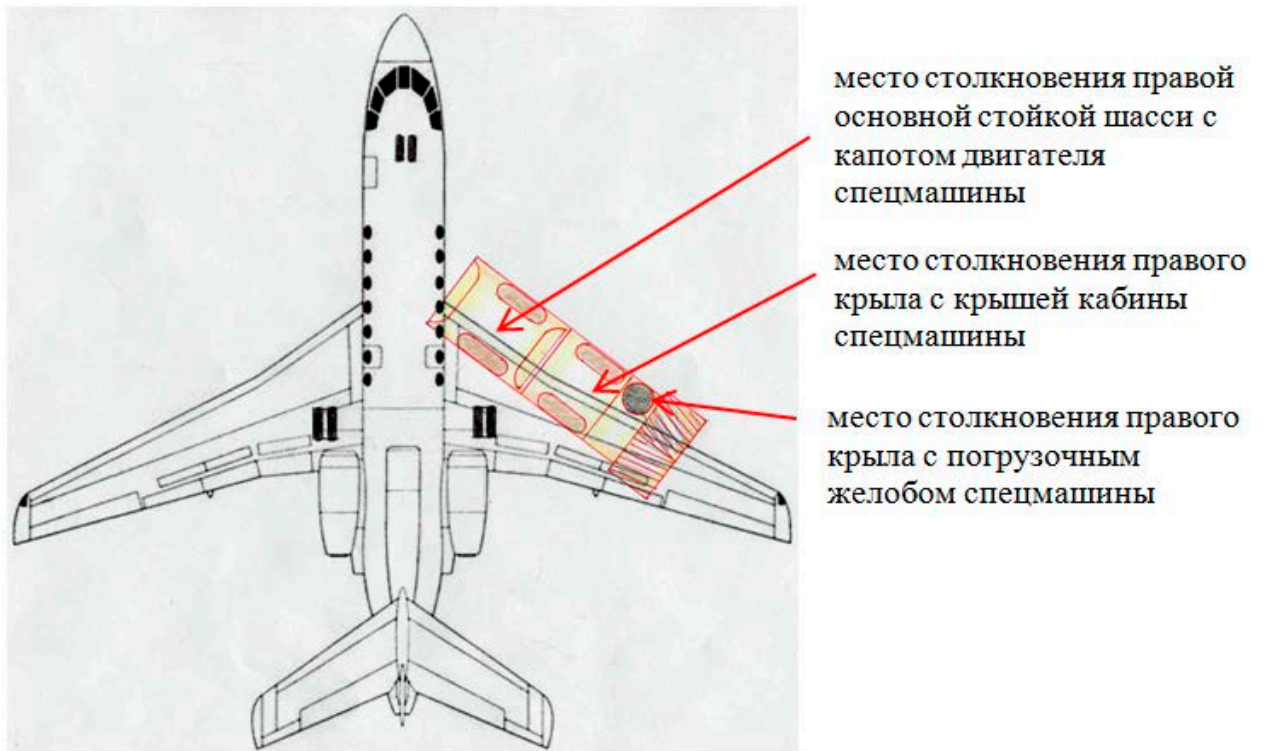

Figure 84. Collision of Falcon 50EX F-GLSA and snowplow 3

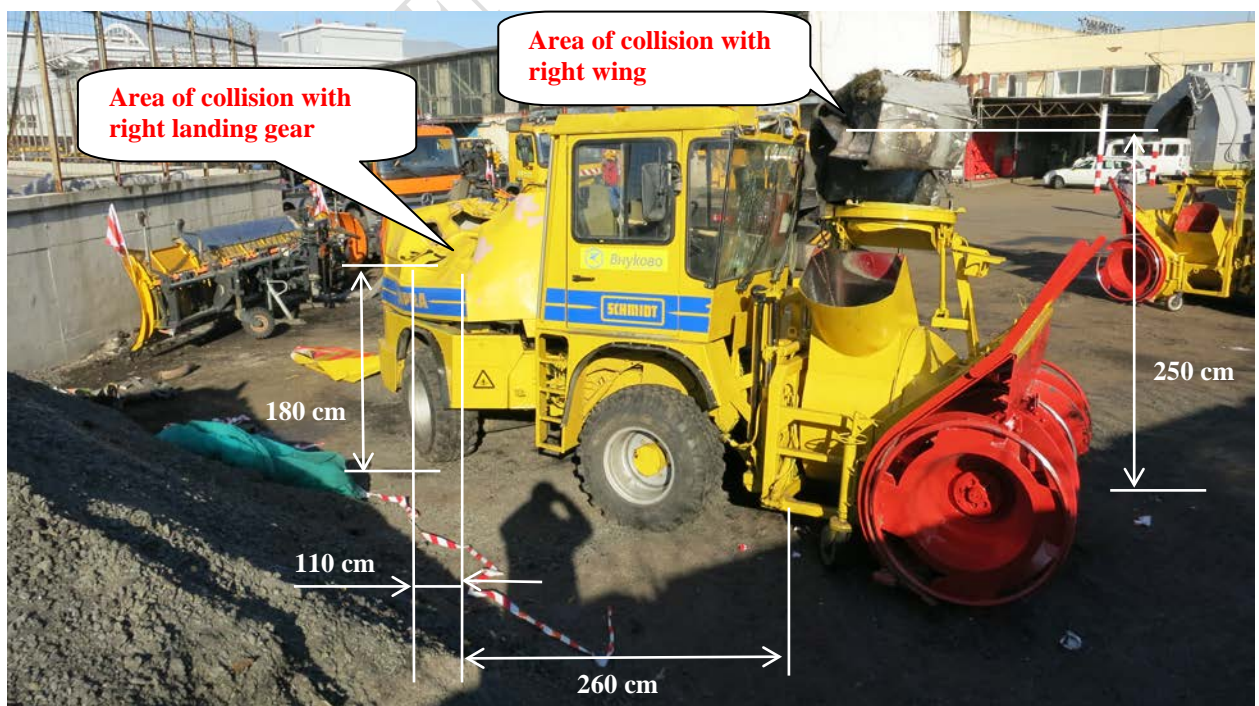

Figure 85. Location of aircraft parts hitting the snowplow

At the time of the collision the flight parameters were as follows:

- indicated airspeed - 133 kt (246 km/h);
- pitch angle - 18 degrees;
- local AOA - 22 degrees;
- N1 of Engines № 1, 2 and 3 - respectively 87.4%, 89.2% and 87.4%.

Figures 87 to 89 show the aircraft position recorded by airdrome surveillance cameras TK 071 and TK 072 at the moment of collision as well as 1 and 3 seconds afterwards.

After the collision, due to the damage of the RH wing, the aircraft experienced abrupt right bank. Full left input of the control column by the crew could not counteract the right bank and after about 250 m, inverted, the aircraft hit the ground, crashed and caught fire.



Figure 86. Location of objects at airfield Vnukovo as viewed from the departure controller screen at 19:58:10 during the Falcon-50EX F-GLSA aircraft collision with snowplow 3



Figure 87. Collision of Falcon 50 EX F-GLSA and snowplow 3 at 23:58:10 (19:58:10 UTC) (shown by arrows)



Figure 88. Position of Falcon 50EX F-GLSA aircraft 1 second after the collision at 23:58:11 (19:58:11 UTC) (shown by arrows)

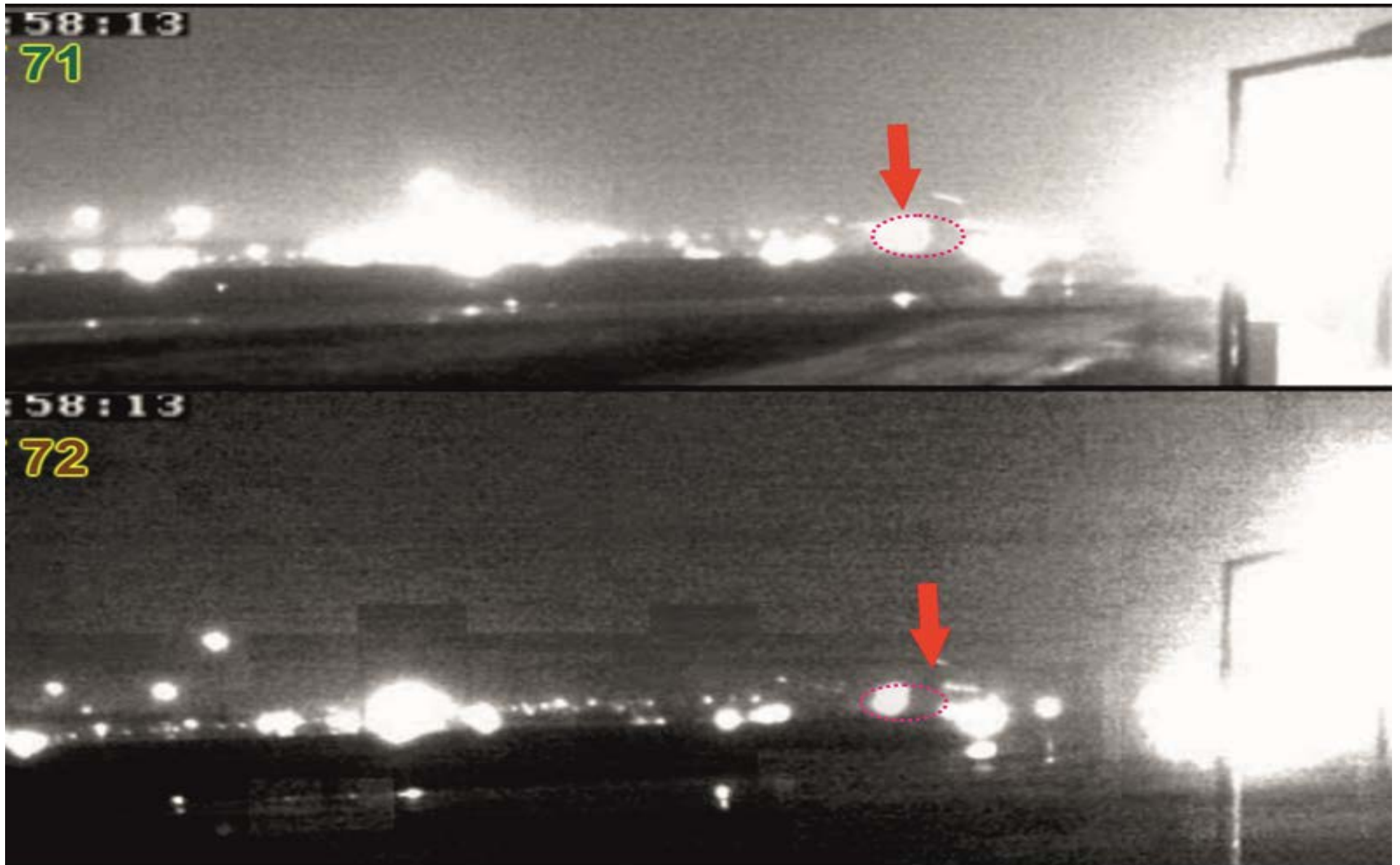

Figure 89. Position of Falcon 50EX F-GLSA aircraft 3 seconds after the collision at 23:58:13 (19:58:13 UTC)

2.2. Analysis of Aircrew, ATM and Airdrome Service Staff Actions

As follows from the history of flight and events sequence described in Section 2.1 the accident occurred as a result of the collision of the aircraft taking off after being cleared for takeoff with the snowplow making runway incursion. However, there was some information which timely used could have prevented the accident available to the both aircrew and airdrome shift supervisor and also transferred by the airfield surveillance and control subsystem A3000 to screens at departure and ground controllers WPs as well as ATC shift supervisor's WP.

Statistics show that runway incursions occur almost every day worldwide but they do not result in accidents (based on the available information, there haven't been similar occurrences in commercial aviation within the recent 5 years before the accident in question).

The Report below does not only analyze causes of the runway incursion made by the snowplow, but also states the investigation team's opinion why the applicable defences²⁹ did not work in that particular case.

2.2.1. Analysis of Airdrome Service Staff Actions

The initial training of drivers was conducted at JSC Vnukovo Airport in accordance with Guidance Material by Rosaviatsiya as of 13.05.2013 as well as Instruction on Initial Training of Drivers and Supervisors over Vehicle Movements Towards and From Aircraft, on Training of Persons Responsible for Accompanying Vehicles of Third Parties at the Airfield and Access of Third Parties to the Airdrome" approved by Order of JSC Vnukovo AP № 104 as of 17.03.2014.

The initial training of drivers was conducted according to various programs depending on their duties. Thus, the airdrome vehicle drivers' training program (authorizing to do airfield maintenance) was approved by the General Director of Vnukovo AP on 14.03.2014.

The lecture notes for the airdrome vehicle drivers' training sessions (authorizing to do airfield maintenance) were approved by the Deputy General Director of JSC Vnukovo AP in March 2014.

Drivers of snowplows 1, 2 and 3 as well as the driver of the airdrome shift supervisor's car had had working experience at Vnukovo airdrome of over 3 years each. Those drivers underwent initial training during induction period when they were employed to the airdrome service of Vnukovo AP.

Within the framework of seasonal training for fall 2014/winter 2015, a team assigned by Order № 249 of Vnukovo AP General Director as of 26.09.2014 within September 22 to

²⁹The term "defence" is applied as being used in documents prescribing the development of safety management systems.

October 10, 2014 delivered training to drivers of airdrome service vehicles (training records have not been provided to the investigation team) and conducted testing to check their knowledge of safety regulations.

The testing was recorded by protocol № 2 as of 10.10.2014. Based on the mentioned protocol Order № 2988/П of Vnukovo AP General Director "On admittance airdrome vehicle drivers to work in autumn 2015/winter 2016" was issued as of 14.10.2014. The drivers of snowplows 1, 2 and 3 had passed the mentioned testing according to the provided documents.

The list of checked documents included among all Instruction № 82, Instruction on Airdrome Vehicles Traffic Management at Vnukovo Airdrome as well as Technology on Coordination of Airdrome Service with the Vnukovo ATC Center.

It should be noticed that the form of records of airdrome cars and vehicles drivers' knowledge testing used during the preparation for the autumn 2014/winter 2015 operations did not comply with the Manual on Operation and Maintenance of Airdrome Transport of the Russian Federation.

Protocol № 2 as of 10.10.2014 mentions Order № 315 of General Director of JCS Vnukovo Airport "On assigning vehicles in autumn 2014/winter 2015" signed on 16.10.2014, that is 6 days after tests of its contents had been passed.

In accordance with Para 5.1 of Instruction on Airdrome Vehicles Traffic Management at Vnukovo Airdrome, vehicle drivers of Vnukovo AP shall pass medical check before and after their duty. A medic shall make a record in a driver's roadmap on passing a medical check and admittance to work before the duty and on passing a medical check after the duty.

Before starting his duty, the driver of snowplow 3 underwent a medical check at the medical unit of Vnukovo AP, confirmed by a remark in roadmap № 53825 and duty release of the driver. A record of the medical check passed by the driver was also made in the Log of pre-duty medical check of shift 3 drivers.

It should be noted that the medical check at the medical unit of Vnukovo AP was conducted with violation of requirements stated in Letter of Russian Ministry of Health "On pre-duty medical checks of transportation vehicle drivers" № 2510/9468-03-32 as of 21.08.2003:

- before the duty the blood pressure and heart rate of the checked driver were neither measured nor recorded in the Log of pre-duty medical check of shift 3 drivers, only the time of the check was recorded.

Note: *Extract from Letter "On pre-duty medical checks of transportation vehicle drivers" № 2510/9468-03-32 as of 21.08.2003:
Arrangement of pre-duty medical checks of transport vehicles.*

The body temperature is measured if there are objective indications.

During the check blood pressure and heartbeat shall be checked.

2. Extract from the explanation of head of Vnukovo AP medical unit - chief doctor № 56-181 as of 10.12.2014:

Pre-duty medical checks of transport vehicles are conducted as per Letter № 2510/9468-03-32 of Russian Ministry of Health "On pre-duty medical checks of transportation vehicle drivers" as of 21.08.2003.

3. Extract from the explanation of medical assistant of Vnukovo AP medical unit № 10.12.2014 as of 10.12.2014:

"The procedure of medical check of drivers before and after duty is determined by Document № 2510/9468-03-32 as of 21.08.2003 "On pre-duty medical checks of transportation vehicle drivers" and oral order of head of polyclinics (name of head) that if there are a lot of drivers passing medical checks, blood pressure shall be measured if there are pertinent indications in order to avoid crowding and flight delays'."

The experiment conducted by the investigation team to determine the time required for the driver's medical check revealed that the present medical staff of the Vnukovo AP medical unit was not sufficient to provide complete medical checks of drivers in the established timeframes.

In violation of Para 5.1 of Instruction on Airdrome Vehicles Traffic Management at Vnukovo Airdrome prescribing that medical checks shall be passed by all drivers before and after the duty, head of Vnukovo AP medical unit - chief doctor made an oral order to conduct medical checks after the duty only if required. The investigation team notes that in fact before the day of the accident post-duty medical checks were conducted formally (only exterior was assessed).

Note:

In accordance with Resolution № 57 "On pre-duty medical checks procedure for vehicle drivers and pre-duty health control of Vnukovo AP personnel" as of 09.01.2014:

Pre-duty (post-duty) medical checks of vehicle drivers as well as pre-duty health control shall be conducted before each duty shift and, if required, in the course of the duty and after the duty in pre-duty check rooms".

The airdrome shift supervisor did not pass a medical check as it was not prescribed by documents determining his scope of operations.

After the accident the snowplow 3 driver (at 22:09, that is 2 h 11 min after the accident) and the airdrome service shift supervisor (at 23:32, that is 3 h 34 min after the accident) passed alcohol testing. The testing was done with the help of a Drager Arem device. Two measurements were made with an interval of 20 minutes.

The measurements taken from the airdrome service shift supervisor revealed alcohol content of 0.19 mg/liter (milligram for one liter of exhaled air) and 0.17 mg/liter respectively. According to conclusion made by head of recurrent and complicated forensic expertise department of Russian Forensic Medical Expertise (name) as of 29.12.2014, the measurements are compatible with alcohol to blood ratio of 0.4 and 0.36 ‰, which means insignificant alcohol effect at the time the measurements were taken, that is alcohol had been consumed but with minor effect.

The measurements taken from snowplow 3 driver revealed alcohol content of 0.62 mg/liter and 0.6 mg/liter respectively. According to conclusion made by head of recurrent and complicated forensic expertise department of Russian Forensic Medical Expertise (name) as of 29.12.2014, the measurements are compatible with alcohol to blood ratio of 1.3 and 1.26‰, which means slight alcohol effect at the time the measurements were taken.

The investigation team holds documents confirming the fact that the snowplow 3 driver consumed alcohol on 20.10.2014 during the duty after the pre-shift medical check.

Taking into account the actual time intervals passing after the accident before the measurements were taken, the investigation team assumes that alcohol could have affected the actions of the snowplow 3 driver and airdrome service shift supervisor. The analysis of their actions is presented below.

Note: *Extract from Instruction on Airdrome Vehicles Traffic Management at Vnukovo Airdrome:*
Para 5.1 Warning: Drivers are prohibited to drive a vehicle under the influence of psycho-active substances (alcohol, drugs, etc.) or medications deteriorating reaction and concentration, experiencing disease or fatigue threatening safety of traffic.

The investigation team also notes that a mandatory post-duty medical check conducted in full scope could have significantly mitigated the risk (probability of hazardous outcome) related to drivers operating on the airfield under the influence of alcohol.

Snow cleaning operations had been also conducted on the airfield by the previous shift of the airdrome service. As the duty shift was transferred the previous shift supervisor reported that

operations at TWY B8 were to be completed. At the time of the aircraft takeoff, operations on the abovementioned taxiway were coordinated by the airdrome service shift supervisor with the ATC shift supervisor and the Airport Director on Duty. The mentioned taxiway is located at a safe distance from RWY 1. Snow cleaning operations at RWY 1 were scheduled for a much later time.

To start operations at TWY B8 the airdrome service shift supervisor's car and the three snowplows had to cross the RWY in use from TWY A3 to TWY A4 (Figure 27 and Figure 28).

Note:

Extract from Instruction № 82:

Para 34. Service vehicles can only enter runways or taxiways for operations if approved by the ATC shift supervisor and cleared by a departure (tower, ground) controller and only being accompanied by a person responsible for the operations.

Para 42. Before crossing or entering a runway, a vehicle driver or service representative after reaching the marked holding point, shall request clearance to cross or enter the runway from the departure (tower, ground) controller, and after being cleared shall cross or enter the runway.

Thus, crossing or entering a runway is only permitted upon clearance from a controller, moreover, in accordance with control areas, clearance to cross (enter) the runway in use shall be requested from the departure controller, while clearance to cross another runway or enter taxiways shall be requested from the ground controller.

Technically, all airdrome vehicle drivers have a possibility of requesting clearance from a controller (communication with ground and departure controllers at internal airdrome communication frequencies). However, according to the established procedure, snowplow drivers only get directions from the airdrome service shift supervisor who, in his turn, gets clearances for specific actions from controllers, that is all operations of snowplow drivers shall be conducted under the supervision of the airdrome service shift supervisor.

Before crossing the RWY in use from TWY A3 to TWY A4 the airdrome service shift supervisor made a relative request to the departure controller. After being cleared by the controller, the airdrome service shift supervisor and snowplows crossed the RWY followed by a pertinent report of the airdrome service shift supervisor, meaning the procedure was complied with. Then the airdrome service shift supervisor informed the ground controller on the start of the operations at TWY B8 and got the applicable clearance, in compliance with the procedure.

Almost after the start of the operations an abnormal situation appeared - failure of one of the vehicles. The airdrome service shift supervisor decided to send this vehicle to be repaired and

accompanied it as it crossed the RWY back. All requests and reports to the departure controller were done in a standard way.

However the airdrome service shift supervisor did not inform the controller on the vehicle failure. The investigation team notes that Para 39 of Instruction № 82 and Para 4.3.6 of Instruction on Airdrome Vehicles Traffic Management at Vnukovo Airdrome reveal some ambiguity concerning the actions required from the airdrome service shift supervisor in case of vehicle failure. Thus, Instruction № 82 requires immediate report to the departure, tower or ground controller in case of vehicle failure. While the internal instruction of Vnukovo airdrome requires only reporting to the departure controller, that is, based on the control areas, such report is mandatory only in case the failure occurred at a runway in use of adjacent parts of taxiways.

Note: *Extract from Instruction on Airdrome Vehicles Traffic Management at Vnukovo Airdrome:*

Para 4.3.6. In case of airdrome vehicles failure a person responsible for the operations shall immediately report this to the departure controller and take urgent actions to get the failed vehicle off the runway and taxiways to a designated location".

Extract from Instruction № 82:

Para 39. In case of a vehicle failure the person in charge of the operations shall immediately report to a departure controller (tower controller or ground controller)...

Despite the mentioned ambiguities in the documents, the investigation team believes that the airdrome service shift supervisor in any case should have reported to the ATC on the vehicle failure.

The two snowplows (1 and 3) continued operations at RWY B8, moving along the right side of the TWY towards TWY A8, being unsupervised.

Note: *Extract from the interrogation of (name of the airdrome service shift supervisor) as of 21.10.2014:*

"Meanwhile (while I was dealing with the vehicle of (name)) I was not supervising the operations of the vehicles of (names of two drivers)".

Extract from Instruction on Airdrome Vehicles Traffic Management at Vnukovo Airdrome:

Para 4.3.3 During airfield operations, the accountable person of the service in charge of the operations shall ensure the vehicle

traffic, supervision and control of the operations.

The airdrome service shift supervisor had resumed supervision of the vehicles before they entered TWY A8. However the ground controller was not requested to clear the vehicles to enter the TWY and start operations. The ground controller was neither requested to clear the vehicles to enter RWY 2 (out of operation), after they had completed operations at TWYs A8 and B8, that is the airdrome service shift supervisor did not comply with the procedure.

After the detected runway light fragment on RWY 2 was removed and the electrical and lighting service car had left, the airdrome service shift supervisor and two snowplows resumed operations.

Note:

Extract from the interrogation of (name of aerodrome service shift supervisor) as of 21.10.2014:

"After inspecting the runway light they took the fragment and left via the crossing ... along RWY 2. Then we returned to our vehicles and resumed operations. I did not notice if the vehicle of (name of snowplow 3 driver) was in the team. Then my Ford and (name of snowplow 1 driver)'s Frosya vehicle turned back on RWY 2 towards the ILS system..., until 150 m before RWY 1 centerline, to continue operations at the other side of RWY 2. During the turn I noticed that the start of RWY 1 was occupied by an aircraft and English speech was coming from the radio".

Extract from the interrogation of (name of aerodrome service shift supervisor) as of 23.10.2014:

"If I had seen that (name of snowplow 3 driver) had entered the runway in use I would have tried to inform the controller or call him back by the radio, but I did not see him enter the runway. At that time I was at the runway out of operation. I guess (name of snowplow 3 driver) entered the runway while the vehicle team was turning but I did not see the moment. I have not determined the distance between my car and the other vehicles. As far as I know this is not required by regulations, but I should have supervised the operations of the drivers.

The airdrome service shift supervisor's explanations are not compatible with the airfield surveillance and control system data. Thus, the airdrome service shift supervisor states that:

- electrical and lighting service experts left towards the big crossing after taking the runway light fragment, while actually the electrical and lighting service car left in the opposite direction;

- during the turn (19:53:33 is the time snowplow 1 started turning) he saw that there was an aircraft at the start of RWY 1. At the mentioned time the F-GLSA aircraft only started taxiing from the stand to the holding point and there had not been any other aircraft takeoff operations carried out;

- snowplow 3 entered RWY 1 as the other vehicles were turning. Actually snowplow 3 turned left with the vehicle team and first moved from the big crossing towards threshold 01 of RWY 2 along the left side of the runway.

Thus, taking into account the following path of snowplow 3, it can be assumed that after the vehicles started turning in the direction of threshold 01 of RWY 2 (at 19:53:33) the airdrome service shift supervisor lost control of snowplow 3. Most probably, the airdrome service shift supervisor only detected the absence of snowplow 3 after the turn at threshold 01 of RWY 2 (at approximately 19:56:17) as he started moving towards the big crossing (Figure 69).

Note: *Extract from the interrogation of (name of aerodrome service shift supervisor's car driver) as of 31.10.2014:*

"Additionally, after the turn at heading 13, (name of airdrome service shift supervisor) did not find the second snowplow of (name of snowplow 3 driver) and told me to move faster towards the crossing".

The airdrome service shift supervisor did not inform the ATC on loss of control over snowplow 3. Documents regulating the airdrome service shift supervisor's activities do not envisage the hazard connected with loss of control of a vehicle and do not contain applicable guidance. The airdrome service shift supervisor did not take any actions to establish communication with snowplow 3 driver to clarify his location. Instead, he started to look for the snowplow himself, telling his driver to accelerate towards the big crossing. It was even more needed to report to the controller after the airdrome service shift supervisor car stopped at a safe distance from the RWY as his driver had detected the aircraft getting ready for departure (Figure 72). A detailed report could have enabled the controller to delay the aircraft departure until localizing the snowplow 3 and prevent the accident.

Having analyzed the probable causes of the airdrome service shift supervisor failing to report to the ATC, the investigation team notes that if the airdrome service shift supervisor had made such a report, this could have led to investigation that could have determined the fact that the airdrome service shift supervisor had consumed alcohol. If the airdrome service shift

supervisor had requested snowplow 3 driver to report his location, this information would have been available to other airdrome service personnel (including the airdrome service dispatcher) who were within the radio transmission range which could have also led to investigation.

Note: *Based on the available information the airdrome service shift supervisor had another case of a service vehicle executing runway incursion. On June 14, 2010 a departure controller of Vnukovo airdrome instructed a CRJ-200 VQ-BGR operated by Utair Airline to go around due to runway incursion by a cleaning vehicle of the airdrome service. According to the investigation report of that occurrence, the incursion occurred due to the following factors:*

- *violation of regulations prescribing a conduct of pre-duty briefings to vehicle drivers by the airdrome service shift supervisor and another expert (Cat I engineer) directly in charge of the TWY operations;*
- *violation of regulations by the vehicle driver and TWY operations supervisor in terms of airdrome vehicle entering the airfield without being accompanied by a person in charge of the operations and without requesting clearance from the ATC.*

After the airdrome service shift supervisor had detected the absence of the snowplow the crew sequentially received and confirmed clearances from the departure controller to line up and take off. The airfield service shift supervisor was able and actually had to listen to the mentioned radio exchange, as he had his car equipped accordingly (there is evidence that in fact the radio exchange had been listened to). On the other hand, the investigation team received no confirmation that the aircraft service shift supervisor demonstrated a level of English language proficiency at a sufficient level to comprehend the exchange conducted in English. The investigation team notes that English language proficiency at ICAO Operational Level 4 could significantly improve the situational awareness of personnel required to listen to radio exchange during airfield operations.

It should be mentioned that in violation of Para 36 of Instruction № 82 requiring to contact ATC every 15 minutes, the airdrome service shift supervisor did not contact the controller for a time period of 24 min and 15 sec (until the accident) since he had confirmed (at 19:33:55) to the departure controller that he was to contact ground control. However, the Coordination Procedure of Airdrome Service with Vnukovo ATC Center and Other Ground

Support Services at Vnukovo Airdrome does not contain the requirement to establish reference contact between the airdrome service shift supervisor and ATC controller every 15 minutes.

Note: *Extract from Instruction № 82:
Para 36. In the course of runway and taxiway operations a person in charge of the operations shall maintain radio exchange with the departure controller (tower or ground controller) and provides reference contact every 15 minutes.*

Thus, the investigation team considers that even after losing control over snowplow 3, the airdrome service shift supervisor had enough time and information to prevent the incursion of the runway in use, but did not take required actions, that is the existing defenses did not work. The erroneous actions of the airdrome service shift supervisor could have been induced by consumed alcohol as stated above.

Having analyzed the path of snowplow 3 after the turn (at 19:53:33) it can be assumed that after turning towards threshold 01 of RWY 2 snowplow 3 driver lost situational awareness completely as the following movement of his vehicle (Figure 65) could not be explained from a logical point of view:

- after the turn, instead of moving along the right side of RWY 2 (with reference to the vehicle heading) with the motorcade he turned left and moved along the left side of RWY 2. Snowplow 3 driver did not contact his shift supervisor;

Note: *Extract from the interrogation of (name of snowplow 3 driver) as of 21.10.2014:*

"I would like to add that no one from the vehicle team including the lead engineer accompanying the team (name) attempted to contact me due to my lag. At that time I did not contact the ATC either, as I thought I would catch up with the team. Besides I saw their strobe lights on a distance and believed that as I am well aware of the territory of Vnukovo AP, namely the runway and taxiway traffic patterns, I would be able to find them."

- at 19:54:00 the snowplow 3 driver, without any instruction or clear reasons, stopped the vehicle without reaching TWY B8.

- at 19:54:24 snowplow 3 driver without being instructed turned the vehicle and started moving alone along RWY 2 towards RWY 1, probably taking the electrical and lighting service car passing him at 19:54:13 on the left for vehicles of his team;

- having stopped at 19:55:32 before the crossing of RWY 1, at 19:55:40 the snowplow started crossing RWY 1 without making any request;

Note: *Extract from the Coordination Procedure of Airdrome Service with Vnukovo ATC Center and Other Ground Support Services at Vnukovo Airdrome:*

Para 11.12 Under no circumstances an aerodrome vehicle driver is allowed to cross the runway until he receives and confirms the applicable clearance. As soon as the runway is vacated the driver shall report it immediately.

As was mentioned above, snowplow drivers are technically able (having the applicable internal airdrome communication equipment in their vehicles) to contact a departure or ground controller though it is not prescribed by the existing procedure. The investigation team revealed that the radio in snowplow 3 was tuned to frequencies of the departure and ground controllers, that is the driver was able to contact ATC if desired. The regulations do not determine a vehicle driver actions in case of his disorientation or loss of contact with the shift supervisor.

Meanwhile it should be mentioned that communication with Departure and Ground Control is accomplished at internal airdrome communication frequencies but not via VHF channels used for radio exchange between aircrews and ATC. ICAO Doc 9870 Manual on the Prevention of Runway Incursions Para 4.2.6 recommends that «all communications associated with the operation of each runway (vehicles, crossing aircraft, etc.) should be conducted on the same frequency as used for the take-off and landing of aircraft». Thus, this provision was not complied with at Vnukovo AP as applied to vehicles of airdrome service (and some other services).

- after crossing RWY 1, snowplow 3 stopped near the vehicle group standing at RWY 2 near the earthwork site, with its rotor still operating;
- at 19:57:18 snowplow 3 started turning and moving towards RWY 1;
- further the snowplow 3 entered again the runway in use (without request) and stopped almost in the middle of it, followed by the collision with the aircraft.

Evidence of loss of situational awareness of snowplow 3 driver is the path of his vehicle along the airfield (Figure 90) that he attached to the interrogation protocol as of 21.10.2014. The

path drawing provided by snowplow 3 driver is not consistent with his actual movements as per the data from airfield surveillance radar (Figure 91).

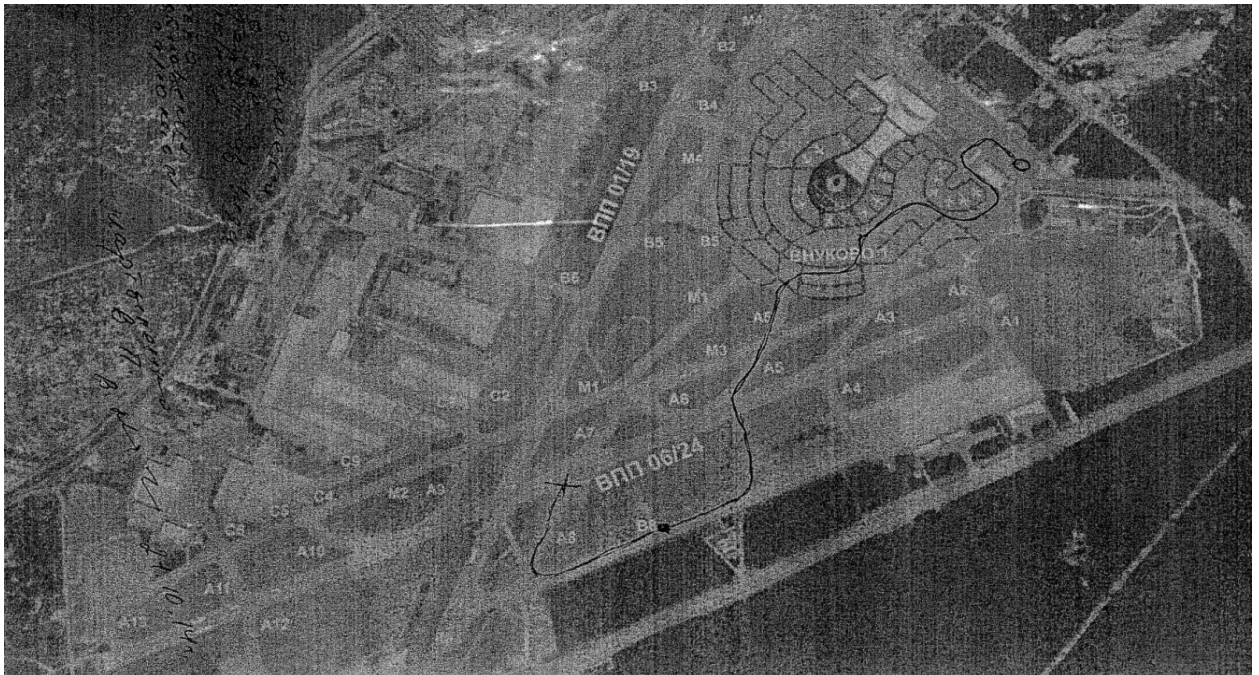

Figure 90. Vehicle path attached to snowplow 3 driver's interrogation protocol



Figure 91. Snowplow 3 path as per the airfield surveillance radar data

The loss of situational awareness and further illogical movement of the snowplow might have been induced by alcohol influencing snowplow 3 driver. Just like in case with the airdrome

service shift supervisor, the failure of snowplow 3 driver to report his situation, could be explained by the fact that this information would have become available to other airdrome service personnel (including the airdrome service dispatcher) who were within the radio transmission range which could have led to investigation and revealed the fact of alcohol consumed.

It was impossible to determine, with information available to the investigation team, why the snowplow driver stopped almost in the middle of the big crossing. Probably the driver stopped to regain situational awareness.

Note: *As has been already noted in Section 1.9.3 the snowplows were not fitted with equipment for the listening of the radio exchange between the departure controller and aircraft flight crew. Potentially if such equipment had been installed and respective additions introduced to the documents that determine the order of the vehicles' drivers work and of the radio exchange conduct, the listening to the radio exchange might have put the snowplow 3 driver on the alert and prevented his entering the runway (as in case with the airdrome service shift supervisor's car driver).*

The investigation team analyzed if there was any signage at the airdrome that could have helped the snowplow driver to regain at least part of situational awareness and avoid entering the runway in use.

Note: *Extract from Job Description of Vehicle Driver (foreign-made two-engine vehicle) of Airdrome Service Vehicle Team № ДИ 12.82-14 (made effective by Order № 263 for Vnukovo AP as of 5.09.2014):*

Para 3.1.14 Know the airdrome map, be well familiarized with the airdrome;

Para 3.1.15 Be attentive when driving a car (vehicle) around the airdrome;

Para 3.1.16 Be careful when driving in adverse weather conditions and reduced visibility.

It should be noted that in accordance with the requirements of Para 42, Instruction № 82 before crossing or entering a runway a vehicle driver or airdrome service representative after reaching a marked holding area shall request clearance to cross or enter the runway from a departure (tower or ground) controller and having received that clearance can cross or enter the runway.

Note: Extract from Instruction № 82:

Para 42. Before crossing or entering a runway, a vehicle driver or service representative after reaching the marked holding point, shall request clearance to cross or enter the runway from the departure (tower, ground) controller, and after being cleared shall cross or enter the runway.

As of 20.10.2014 the crossing of RWY 2 and RWY 1 had not been marked. The investigation team was provided a letter of reference № 12.10-148 from the head of Vnukovo AP airdrome service as of 14.11.2014, stating the following: "... This is to confirm that as of 20.10.2014 there was no signage of beacon critical areas on RWY 2. Signage of beacon critical areas is not required by regulations (AON, CAOM RF-94)". This was confirmed by the Head of Airdrome and Equipment Certification Commission of the IAC upon request by the investigation team.

The investigation team notes that Para 4.1.10 of AON-92 (efficient at the time of the accident) and Para 262 (efficient at present) contain requirements to make such marking only on the crossing of TWY and RWY³⁰. Meanwhile, Standard 5.2.10.7 of ICAO Annex 14 regulates that "the runway-holding position marking displayed at a runway/runway intersection shall be perpendicular to the centerline of the runway forming part of the standard taxi-route."³¹. There was an expert opinion on the necessity of drawing the mentioned marking given to the management of Vnukovo AP in the Report of Inspection conducted on 04.10.2013 by experts of the Airdrome and Equipment Certification Commission of the IAC. At the present moment the marking is in place.

Taking into account significant experience of snowplow 3 driver at Vnukovo airdrome (more than 10 years), he should have been well aware of the holding area signage and such signage might have become that very defense to alert the snowplow 3 driver and prevent the runway incursion. However, taking into account the presence of alcohol in the snowplow 3 driver's organism and his long-term inadequate movements along the airfield the investigation team finds it hardly probable that the presence of the mentioned marking might have prevented the runway incursion in this particular case in question.

³⁰ Simultaneously with the marking, runway indication signs are to be placed on both sides of the taxiway (white inscription on red). On the day of the accident the signs have not been installed on RWY sides either.

³¹ Meanwhile, the mentioned standard does not take into account that apart from crews of the taxiing aircraft, this marking could be used by vehicle drivers.

The investigation team also analyzed the actual path of snowplow 3 after the airdrome service shift supervisor lost control over it with regard to the location of runway lights and various airdrome signs (Figure 92) that could have helped the driver to regain situational awareness.

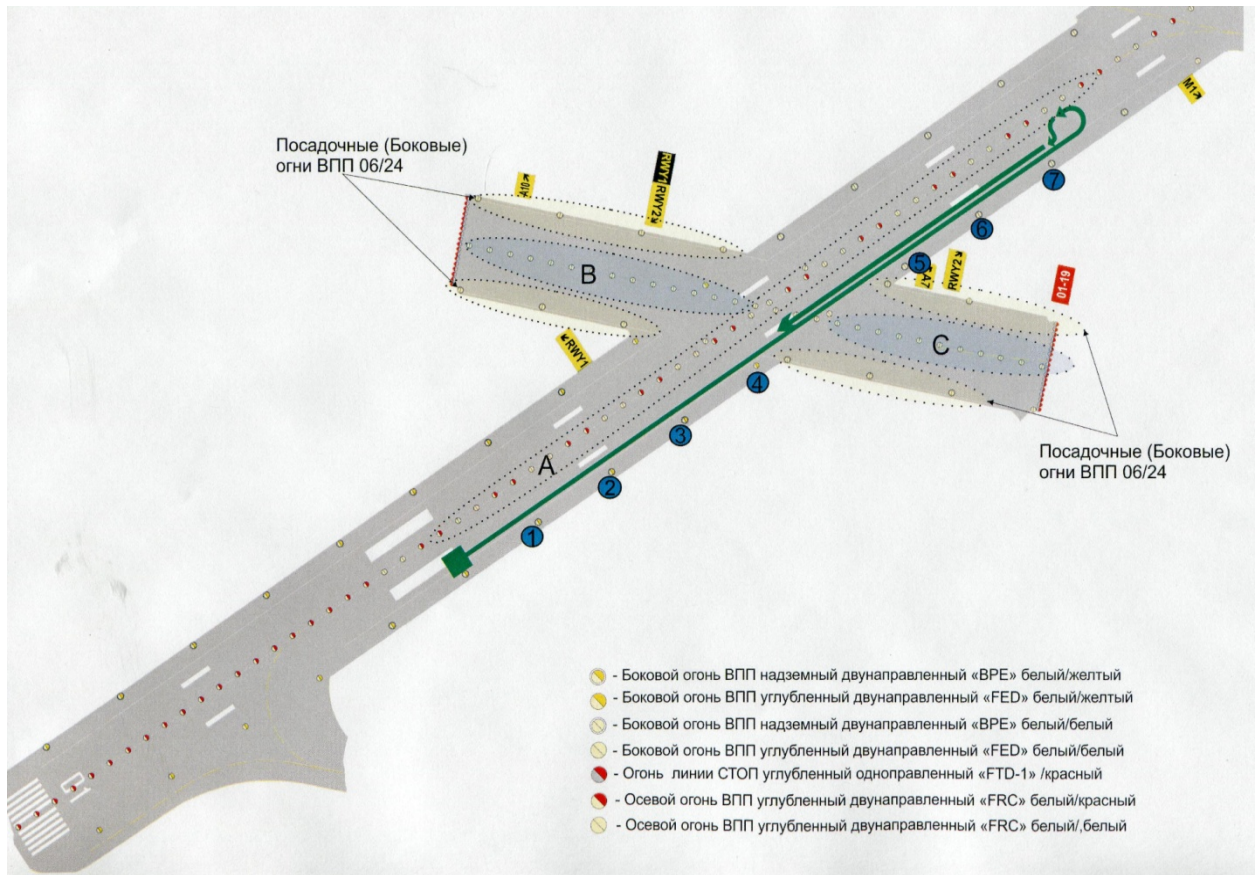

On approach to RWY 1, on the left of RWY 2 there is an airdrome sign with a black inscription RWY 1 and an arrow on the yellow background (AON-92, Para 6.2). According to the information of the electrical and lighting service of Vnukovo AP the sign was illuminated at the time of the accident. When moving from Light 4 to Light 5 there appear RWY 1 centerline lights, equipped with two-directional high-intensity recessed white lights FRC-2-090 set at an interval of 15 m and diverging to the left (B lights group) and to the right (C lights group).

Note: White lights are only set at runways.

On both sides of RWY 1 centerline there are landing (runway edge lights) of RWY 1, two-directional high intensity elevated BPE-1-150 lights set at an interval of 60 meters.

Before the turn snowplow 3 passed at least 3 more white runway edge lights of RWY 2 (Lights 5 to 7 on the chart), located on the right side of the vehicle and at least 9 runway centerline lights of RWY 2 located on the left side (A lights group). Light 5 is a recessed high intensity runway edge light FED-2-200. Lights 6 and 7 are two-directional high intensity elevated lights BPE-1-150.

After turning near Light 7 snowplow 3 started moving along the left edge of RWY 2 in the opposite direction.

After the turn white runway edge lights 7, 6 and 5 were on the left side of snowplow 3 while on its right there was the RWY 01/19 centerline equipped with alternating pairs of red and white two-directional high intensity recessed FRC-2-090 lights.

As snowplow 3 was moving from Light 5 to Light 4 there appeared again RWY 1 centerline lights, (B lights group on the right and C lights group on the left), as well as landing (runway edge lights) of RWY 1.

Thus, the investigation team notes that there were a lot of lighting system elements on the way of the snowplow that could have assisted the driver in defining (provided he had pertinent knowledge and was in a sober condition) that he was on the runway and crossing another runway. The airdrome sign was also indicating that the snowplow was crossing RWY 1. Taking into consideration his significant experience of working at Vnukovo airdrome the snowplow driver could have been guided by the lights and signage, although vehicle drivers do not undergo any specific training on runway lights. The investigation team believes that such training can significantly increase drivers' situational awareness and become one of the defenses against runway incursions.

To conclude this section, according to the information available to the investigation team since 2010 until the accident there occurred 34 runway incursion events at the Moscow (Vnukovo) airdrome. For the purpose of comparison, within the same period there was only one

runway incursion event at the Moscow (Domodedovo) airdrome and 3 occurrences at the Moscow (Sheremetyevo) airdrome, provided the number of takes-off and landings at Domodedovo and Sheremetyevo is higher. The peculiarity of Vnukovo airdrome is the two crossing runways. An analysis conducted within the framework of Vnukovo AP SMS (see Section 1.18.5) revealed that the number of occurrences related to vehicle drivers crossing routes of aircraft and violation of airdrome traffic rules does not decrease. The investigation team believes that the management of Vnukovo AP should improve the SMS (including job descriptions of airdrome service personnel) in terms of hazard identification and risk mitigation during airfield operations with consideration to information in this Report.

2.2.2. Analysis of ATC Controllers and Shift Supervisor actions and Operation of Airfield Surveillance and Control Subsystem A3000

In accordance with Para 2.4 of FAR ATM, one of the objectives of the ATM is prevention of collisions of aircraft on the maneuvering area with obstacles on that area. Identical provisions are stated in particular in Para 1.5 of the Working Instructions of Departure Controller in whose control area the aircraft collided with the snowplow.

Thus, one of the main objectives of airdrome ATM was not reached. This section analyzes deficiencies in the ATM arrangement and provision that affected the flight outcome, including deficiencies in using airfield surveillance and control subsystem A3000.

As was mentioned in Para 1.8.2, Terma Scanter 2001 Airfield Surveillance Radar with the airfield surveillance and control subsystem A3000 (hereinafter referred to as the System or Subsystem) was introduced into operation in September 2013, that is by the time of the accident it had been operated for just over a year. At the time of the accident Vnukovo airdrome was certified for ICAO CAT II operations and was prepared to be certified for ICAO CAT III A operations. In accordance with certification requirements the deployment of the System is not mandatory for ICAO CAT II (though recommended), however it is mandatory for ICAO CAT III A operations. In particular, a Letter from Vnukovo AP General Director to Chairman of Airdrome Certification Board, IAC states that the System will be mandatorily used to provide safety in case of reduced visibility CAT III A operations.

Note: *The investigation team notes that the concept of the A-SMGCS architecture and operation is stated in the ICAO Doc 9830 (first edition, 2004). The system in question shall ensure the following basic functions:*

- *surveillance;*

- *routing;*
- *guidance; and*
- *monitoring.*

With regard to that, according to Doc 9830 surveillance stands for a function of the system which provides identification and accurate positioning information on aircraft, vehicles and obstacles within the designated area.

Identification stands for the correlation of a known aircraft or vehicle call sign with the displayed symbol of that aircraft or vehicle on the display of the surveillance system.

The A-SMGCS actual equipment configuration that was available at the Vnukovo airdrome at the day of the accident provided only limited performance in relation to that described in the Note. Specifically only the detection and positioning of the aircraft, vehicles and other objects located at the airfield within the visibility area and the recognition of conflicts were ensured. However, the automated identification (without any ATC operator intervention) and the surveillance was provided for the arriving aircraft only. As for the departing aircraft the automated identification was not provided (even with an operative transponder), since the A3000 sub-system configuration did not include the MLAT/ADSB functions. The Falcon 50EX F-GLSA might have been identified by manual input, but this was not done, therefore the A3000 sub-system, having recognized the aircraft, automatically labeled it with a track number. The automated identification of the snowplows and the airdrome service shift supervisor's car was not provided either, since they were not fitted with transponder equipment and the A3000 sub-system configuration did not have MLAT/ADSB capabilities.

Working Instructions of Departure Controller and Ground Controller effective on the day of the accident prescribed using the System to accomplish their respective tasks.

Note: *The Working Instructions of Departure Controller and Ground Controller contain no reference that it is necessary to use the TRADIS User Guide. At the same time, for example, a reference is contained to the User Guide of the Synthesis A2(Vn) System (Para 1.11, Working Instruction of Departure Controller).*

Thus, for the purpose of further analysis the investigation team takes it as a fact that the System was actually in operation, that is the procedures of its use had to be defined in the pertinent ATM documents and the personnel using it had to be trained.

According to the provided information, there were almost no malfunctions of the System

within the time of its operation (See Section 1.8.2). A single case of false targets appearing was due to large aircraft standing at certain stands that interfered with the normal operation of the System. Pertinent safety recommendations were given after the investigation of that occurrence.

The investigation team also revealed that on the day of the accident the System operated as per design providing true online radar information to working positions of ATC controllers, as well as information on Reserved Lines being crossed and alerts (warnings of conflicting traffic) in accordance with algorithms of their formation and screen settings at specific working places.

However, the analysis of the available documents and interviews of ATM personnel revealed that the personnel training and the operation of the System at Vnukovo ATC Center was not arranged at an appropriate level.

In fact only three controllers had got certificates from the System designer on passing training as per the designer's training program. None of them worked on the day of the accident.

The investigation team revealed that there were no documents confirming that the controllers working on the day of the accident (ATC shift supervisor, instructor controller, trainee controller and controller 4) had been trained to operate the A-SMGCS System.

Information from the System is provided to screens located at working positions of departure controller, ground controller and ATC shift supervisor.

Within its visibility range the System provides radar control over movement of objects on the airfield and two kinds of alerts in case of Reserved Lines crossing and conflicts including runway incursions (See Section 1.8.2). Controllers can select from their individual working position the kinds of alerts to be shown on their screen.

The reserved line crossing alert logics requires their acknowledgement by the user (controller), that is the alert message remains on the screen until it has been acknowledged by the user (See Section 1.8.2).

The Reserved Lines are normally located before TWY and RWY intersection and can be activated in both directions (to and from the runway) and allow the controller to monitor the runway being entered or vacated. Depending on the control area the controller is able to activate or de-activate the different Reserved Lines but he is not able to change their position or expand the list from an individual working position. Adding Reserved Lines to the list or changing their position is only possible from an engineer working position. The investigation team revealed that the settings of the reserved lines had not been changed since the system was taken into service. The peculiarity of Vnukovo airdrome that is the presence of two intersecting runway was not taken into consideration, meaning Reserved Lines were not placed near the big crossing. Thus, during the runway incursion at the intersection of RWY 1 and RWY 2 the Reserved Lines alert was not indicated on the controllers' screens. This fact is an evidence of poor hazard

identification and risk mitigation with regard to the two intersecting runways (not all technical resources were applied).

Further this Section contains an analysis of individual controllers' actions with regard to their respective duties prescribed in the applicable documents as well as their qualification and training with regard to the operation of the A3000 system and the accident circumstances. The mentioned analysis will show that the departure controller as well as the ground controller and the ATC shift supervisor under certain conditions had an opportunity to both prevent the runway incursion by snowplow 3 and probably decrease the severity of the negative outcome after the incursion.

It should be mentioned above all that all the movements of snowplow 3 (including its initial crossing of the runway in use from the south to the north and the second crossing in the opposite direction followed by a stop on the runway resulting in the accident, both of the crossings had been unauthorized) were correctly indicated by the System on the screens at controllers' working positions. Thus the investigation team concludes that there was necessary radar information at the controllers' working positions and the inadequate movement of snowplow 3 could have been detected long before the accident.

However, there are no provisions in the regulations as for the permanent monitoring by the ATC officers of the A3000 displayed radar information, there are no requirements on conduct of the training on attention allocation when operating the A3000 System and no training on attention allocation when operating the A3000 System was not provided to the Vnukovo ATC Center controllers.

The ATC shift supervisor, in accordance with Para 2.45 of his Job Description decided to join sectors of departure ATS and departure ATC (at 19:05) as well as of ground ATC and ground V (at 19:10). The Job Description of ATC Shift Supervisor did not provide any criteria to take into account when taking a decision to join sectors including the ability of personnel to control the object movements on the airfield using information from the A3000 System screens.

Note: *According to the available information all controllers had had sufficient rest before the duty. The duration of the duty shift before the accident was about 1 h 30 minutes with a low flight intensity. The traffic intensity from 19:05 to 19:57 on 20.10.2015 was 8 departures and 2 landings. The investigation team believes that the accident is not related to fatigue or health of the controllers.*

Ground Controller (controller 4) Actions Analysis

For flights from RWY 1 the following ATM control hand-over lines to departure controller are established for the ground controller: runway-holding position at RWY 2 before RWY 1³² as well as at TWYs A1, A2, A3, A4, A5, A6, A7, A8, A9, A10, A11, A12 and A13.

The ground controller working instruction when accepting duty did not require a check of airfield surveillance and control subsystem A3000 operation on ground controller's working position. However, Para 5.5. of the Working instruction of ground controller defining the controller's actions upon aircrew request for clearance to taxi to holding point requires, apart from other actions, to use the indications of the radar to check absence of obstacles along the taxiing route.

There are also no recommendations on how to set (activate) Reserved Lines and Conflict Detection modes. The investigation team revealed that all conflict detection modes were de-activated at the working position of the ground controller (See Section 1.8.2.1). The activation of Reserved lines is also dubious considering the actual circumstances (the taxiing route of the accident aircraft towards RWY 1 was passing along TWY A11). The TWY A11 to RWY 1 crossing Reserved Line alert was de-activated, but the Reserved Line alert was activated for TWY A10 that was not used for taxiing by the accident aircraft.

The mentioned fact allows assuming that controller 4 did not have required knowledge of A3000 subsystem operation and did not use the System properly. This was confirmed by controller 4 during the interview.

Note: *Extract from the interview of (name of ground controller) as of 4.02.2015:*

1. The question: "Please explain how various types of alerts can be activated from the ground controller's working position" was replied with: "I don't know".

2. Question: "What are Reserved Lines in the A3000 system? How are they activated from the ground controller's working position? Can you show them on the picture of the radar indication screen?" Reply: "These are red lines on the taxiways adjacent to the runway near runway-holding position. They are present on the radar indication screen of the ATC shift supervisor, but not on my

³² There was no signage on the RWY as stated above.

working position. I do not know why they are not."³³

3. Question: "What is the alert signal? How does it look on the screen? What kind of information is provided?" Reply: "I find it difficult to answer this question".

Most probably, due to lack of appropriate knowledge on the A3000 system use, the ground controller did not react to the alert on Reserved Line crossing made from TWY B8 to RWY 2 (threshold 01)³⁴ by the two snowplows and airdrome service shift supervisor's car as the vehicles crossed the B8 to RWY 01 Reserved Line the A3000 screen indicated, among others, the following alerts:

- at 19:42 772 crossed B8-01;
- at 19:42 1878 crossed B8-01;
- at 19:43 2163 crossed B8-01;

where: 772, 1878 and 2163 are track numbers assigned by the System to the vehicles.

Note: *At various time moments the same objects (including the snowplows) were assigned different track numbers by the airfield surveillance and control subsystem A3000. The track number is an internal number used by the System. Its assignment to a specific objects means that the object is identified by the System.*

According to the ground controller's explanation the information on the airdrome service special vehicles operation at RWY 2 had not been brought to her notice. Crossing of the B8-01 Reserved Line occurred in the control area of the ground controller so according to the working instruction the ground controller was to check the reasons for vehicles entering threshold 01 of RWY 2.

Note: *Working Instruction of Ground Controllers:*

1. General

1.7.2.1. Shall conduct monitoring of aircraft movement by means of visual observations (within acceptable visibility) ... and perform control of vehicles movement on the airfield using Kenwood radio equipment.

1.9 The ground controller shall provide constant monitoring of all

³³ The investigation team revealed that the Reserved Lines were not indicated on the ground controller's screen as the relative indication mode was de-activated, which is evidence of personnel actually being not trained on how to use the System.

³⁴ This Reserved Line was activated on the ground controller working position.

flights over the airdrome and in the airdrome terminal area including movement of vehicles and persons in the maneuvering area. The monitoring is provided by means of visual observation.

3.3 The clearance to enter or cross an inoperative runway shall be given by a ground controller in charge of the inoperative sector of the runway.

5.14.2. The radar of the airfield surveillance and control subsystem A3000 of the A-SMGCS shall be used in addition to visual observation of traffic on the maneuver area as well as to ensure traffic observation of those areas that cannot be observed visually.

5.14.3 Information shown at the A-SMGCS indicator shall be used to:

a) ensure monitoring of aircraft and vehicles in the maneuverable area in terms of their compliance to clearances and guidance;

...

c) get information on the basic traffic in the maneuverable area or near it;

d) identify aircraft and vehicle location in the maneuverable area.

The investigation team revealed that at the time of the accident the alert list on the ground controller's screen from the moment he accepted duty contained 22 unacknowledged alerts³⁵. This is a confirmation that the ground controller did not actually use the A3000 system. Being untrained, the controller did not react to the red on the screen, that is the system designer's logics that each alert shall be comprehended and acknowledged (interpreted) by the user did not work in that case.

Note: *Extract from the interview of (name of ground controller) as of 4.02.2015:*

Question: "On 20.10.2014, according to the archive data of A3000 system when the vehicles entered RWY 2 from TWY B8 the radar indicator on you working position showed alerts: at 19:42 772 crossed B8-01; at 19:42 1878 crossed B8-01; at 19:43 2163

³⁵ The investigation team has revealed that there had also been unconfirmed alerts during the work of the controller of the previous shift.

crossed B8-01. Did you see these alerts? How were you expected to react to them? How did you actually react?" Reply: "I did not see the alerts as I was not looking at the radar indicator, I was busy doing other work. There is no guidance in my job description or working instruction on what to do in case alerts appear. I did not see the alerts so I did not react to them."

Thus, using the A3000 system information the ground controller could have identified the runway incursion by the airdrome vehicles onto RWY 2 long before the accident and might have prevented the accident by this. Being untrained on the use of the System the ground controller was not able to accomplish her duties properly.

Note: *Visibility of threshold 01 of RWY 2 from the Ground 1 controller's working position is obstructed due to Tower glazing beams. Another obstruction to visibility is caused by the presence of ATC shift supervisor on his working position.*

The investigation team also noted a number of deficiencies in the work of the ground controller that did not affect the outcome of the accident flight but can have negative effect on flight safety in other circumstances. When the aircrew requested clearance to start up the engines, they named a wrong stand number. The ground controller did not notice that. Confirming the taxiing route the crew mentioned a wrong taxiway to use. According to the working instruction the ground controller was to request the crew to read back the message. This was not done.

Note: *Working Instruction of Ground Controllers:
1.20 If the crew did not read back the message transmitted by Ground 1 ATC, to avoid misunderstanding the controller shall request the crew to read back the following messages:
- change of taxiing route, stand and route.*

Analysis of Controllers' Actions on Departure Control WP

At the time of the accident the instructor controller and the trainee controller were at the Departure ATC working position after the relative sectors had been joined. ATM was provided by the trainee controller under supervision of the instructor controller.

The trainee controller did not hold an aviation personnel license and as mentioned in Section 1.18.2 had been undergoing the on-the-job training in compliance with Order № 93 of the Russian Ministry of Transport. Para 18, Section III of the mentioned order regulates that

"Practical training shall be conducted at the ATC simulator and working position in accordance with an approved plan and included a demonstration of air traffic control by an instructor controller, *trainee working as an air traffic controller under supervision of an instructor controller*, familiarization with the work of adjacent ATC units, debriefing of typical errors, as well as fulfilling training tasks at the ATC simulator under the supervision of simulator instructor controller." It should be mentioned that conduct of air traffic control (even under supervision of an instructor controller) by a trainee controller not holding an aviation personnel license contradicts the provisions of Para 1, Article 53 of the Air Code of the Russian Federation: "functions of ... air traffic control can be only performed by persons belonging to civil aviation personnel, *holding relative licenses issued by the civil aviation authority*". Thus, it is concluded by the investigation team that the mentioned provision of Order № 93 of the Russian Ministry of Transport contradicts the provisions of the Air Code of the Russian Federation.

In accordance with Para 1.6 and 1.7 of the Working instruction of the departure controller, it is possible to unite the functional duties of the ATC controller and ATS controller; if only one controller is working, the ATC controller performs both his duties and the duties of ATS controller.

The position of the instructor controller and trainee controller at the ATM departure controller WP is shown in Figure 93.



Figure 93. Positions of trainee controller and instructor controller at Ground Control at the time of the accident (judging by drawings attached to the interrogation records)

When aircraft takeoff from RWY 1 the control hand-over boundary from ground control to departure control is the moment the aircraft is at holding point.

The departure controller working instruction when accepting duty requires a check of equipment at the working position including the operation of airfield surveillance and control subsystem A3000 of the A-SMGCS system.

Note: *Working Instruction of Departure Controller:*

2. Preparing for Duty and Accepting Duty.

2.4.2. Check:

- operation of airfield surveillance and control subsystem A3000 of the A-SMGCS system".

However, just like for the ground controller, the procedure for the check or the recommended settings of the System (including activation and deactivation of alerts) are not determined in the documents regulating the work of the departure controller. The actions of departure controller in case of any type of alert appears are not determined either.

The investigation team revealed that, like on the ATC ground controller's WP, all conflict detection modes were de-activated on the working position of the ground controller (See Section 1.8.2.1).

As the vehicles crossed the B8-01 Reserved Line³⁶ and during the incursion of RWY 2 (that was not in use) mentioned above, the A3000 screen of the departure controller indicated, among others, the following alerts (Figure 94):

- at 19:42 772 crossed B8-01;
- at 19:42 1874 crossed B8-01;
- at 19:43 2163 crossed B8-01;

where: 772, 1874 and 2163 are track numbers assigned by the System to the vehicles.

³⁶ This Reserved Line was activated on the departure controller working position, though was not in the control area of the departure controller.



Figure 94. TRADIS indicator on departure controller's WP at 19:43:28
(light red table shows information in the alert list)

Controllers at the departure controller's WP did not react to the appearance of these alerts. Like in case with the ground controller, the documents regulating the departure controller's duties did not determine their actions when alert signals appear on the screen. Moreover, it is not possible to manage the TRADIS system (including acknowledgement of alert messages) from the Departure ATC position. As was described in Section 1.8.2.1, acknowledging alerts was only possible from the departure ATS working position. This is also true for the screen settings (the picture shown and the setting modes at departure ATC and departure ATS are identical, but it could be managed only from the departure ATS WP) that is after the sectors had been joined proper use could only be provided from the departure ATS WP which had not been considered in the working instruction of the departure controller when the decision to join the sectors had been taken.

It should be noted that visual observation is defined as the main method to control the departing aircraft for the departure controller. Figure 95 gives a schematic view of the sectors where visual observation could be obstructed from the working positions of the instructor controller and trainee controller.

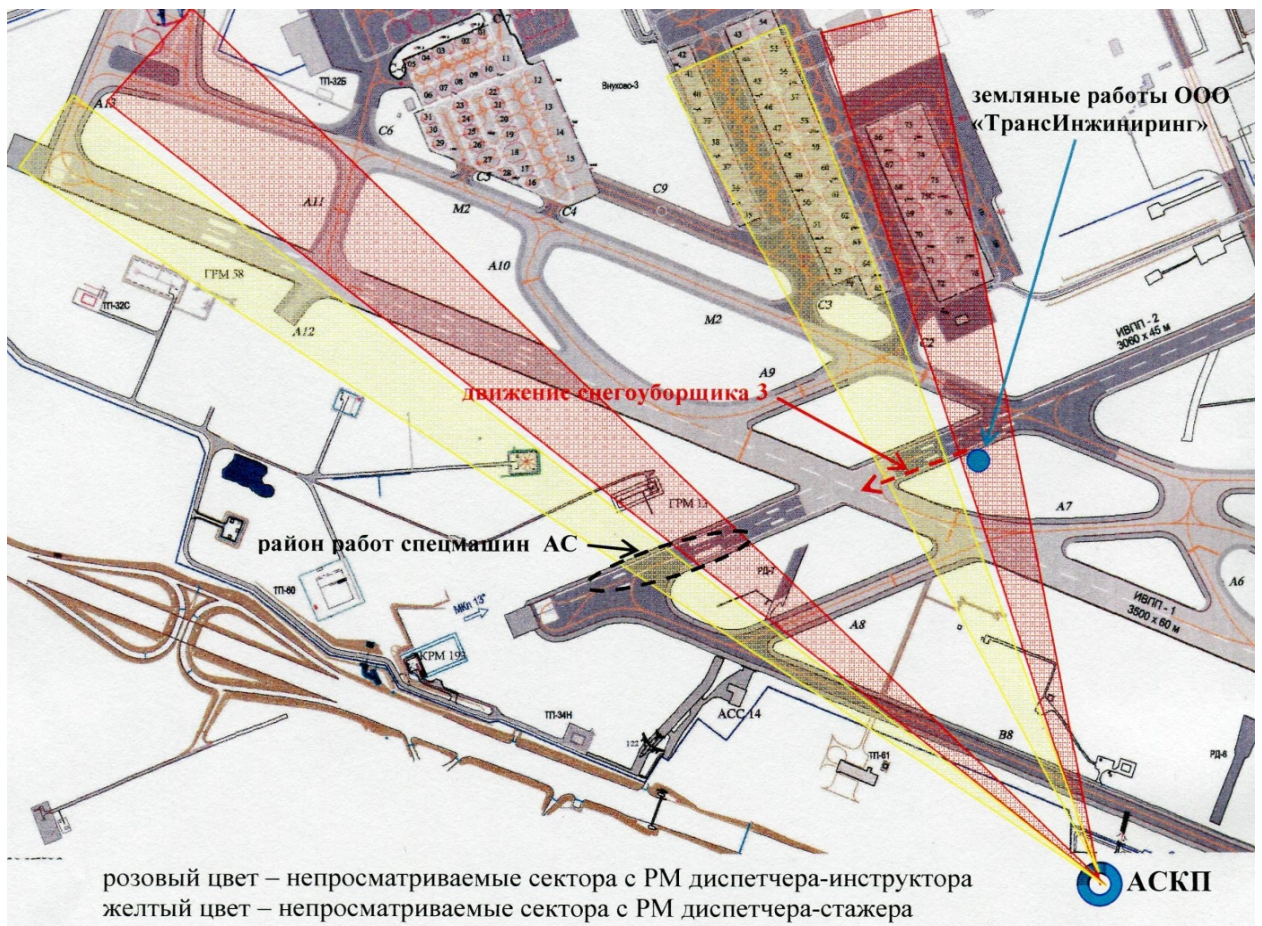

Figure 95. Sectors where visual observation is obstructed from departure ATC WP

It can be seen in the Figure that the area where the snowplow 3 was before entering the runway was in the obstructed visibility area from the departure controller's working position. As the control room is located 37 m above the ground the visibility range could have been further reduced due to complicated weather conditions at Vnukovo AP at the time of the accident (clouds with rough cloudbase: 30 m on threshold 24 and 70 m on threshold 06 of RWY 1, light drizzle and fog, night time). This situation is regulated by Para 5.2.2 of FAR-293: "A controller, visually monitoring the aircraft movement shall have complete visual range of the controller area from their working position. In case it is impossible to ensure complete visual observation of the control area from a certain working position there shall be technical means of monitoring or additional air control offices (sectors)." In the considered case the A3000 system ensured required monitoring of the complete control area of the departure controller. However, use of technical means of monitoring as addition to visual observations required additional training of controllers on the usage of the means, including attention allocation, which was not ensured in the case under consideration.

Further there is a table containing duties of the departure controller (in accordance with the working instruction) during aircraft takeoff as well as actual actions³⁷.

Actions as per Working Instruction	Actual actions
<p>Para 5.2.1.1.</p> <p>Identify the taxiing aircraft using visual observation, data from A-SMGCS A3000 ...</p> <p>Establish contact with the aircraft crew at holding point.</p>	<p>Accomplished, aircraft accepted for control and contact established at the defined point (holding point).</p>
<p>Para 5.2.1.1.</p> <p>Assess the air traffic... using visual observation, data from Synthes-A2 (Vn) and A-SMGCS A3000.</p> <p>Ensure there are no obstacles on the runway using visual observation, data from A-SMGCS A3000.</p> <p>Clear the crew to line up and take off...</p>	<p>Accomplished. At the time of the clearance the runway was free of obstacles. Snowplow 3 and other vehicles near the runway in use were at safe distances from it and were not moving towards the runway (Figure 96).</p> <p>1. Extract from the interrogation of the instructor controller as of 21.10.2014: <i>"Then, (name of the trainee controller), under my supervision, cleared the aircraft for takeoff, before that I ensured there were no obstacles on the runway visually within the visibility range and by the airfield surveillance radar".</i></p> <p>2. Extract from the interrogation of the trainee controller as of 21.10.2014: <i>"Then, I looked visually at the runway and also using the airfield surveillance radar to check if there were any obstacles on the runway. There were no obstacles so afterwards, under the supervision of my instructor, I instructed the aircrew: "cleared for takeoff, runway 06".</i></p>

³⁷ The table only shows those sections of the working instruction that directly refer to the accident circumstances.

	<p><i>Question: "How did you realize the aircraft started the takeoff roll?"</i></p> <p><i>Reply: "I first looked, with my instructor, at the airfield surveillance indicator where I saw that the aircraft blip started moving and then, together with (name of instructor controller), according to the same working instruction, I started visually monitoring the path of the aircraft movement, thought the aircraft as such could not be seen, I could only see its lights. I would also like to add that according to the departure controller's working instruction the controller shall conduct visual monitoring of the taking off aircraft until it has reached the height of 200 m".</i></p> <p><i>3. Extract from the interrogation of the trainee controller as of 25.11.2014:</i></p> <p><i>"At the time I gave the clearance the runway was clear, nobody requested crossing the runway in use and I did not have any information on the conducted operations and possible crossing of the runway".</i></p>
--	---



Figure 96. Location of objects at airdrome Vnukovo as viewed from the departure controller screen at 19:56:55

It is also clear from Figure 96 that after the aircraft crossed the Reserved Line between TWY A11 and the RWY, the controller's screen indicated the pertinent alert (track number 2191 belonged to Falcon 50EX F-GLSA aircraft). This alert was not acknowledged by the controller.

In the course of the aircraft takeoff the working instruction (Para 5.2.1.1) requires to "monitor the taking off aircraft until it has reached the height of 200 m within the visibility range and in case any visual sign of malfunction is identified the controller shall immediately report that to the aircrew". Based on the mentioned text, monitoring of the taking off aircraft shall be conducted visually within the visibility range. It is not mentioned in the mentioned paragraph that the takeoff shall be monitored with the help of A3000 system.

Para 5.9.2 of Section 5.9 "ATC Monitoring Systems" determines the following: "the radar of the airfield surveillance and control subsystem A3000 of the A-SMGCS shall be used in addition to visual observation of traffic on the maneuver area as well as to ensure traffic observation of those areas that cannot be observed visually." The following paragraph (para 5.9.3) specifies the use of information from the A-SMGCS system, among other things, to

"... identify if the runway is clear before takeoff or landing". As can be seen from the information above, there are no requirements to monitor the course of aircraft takeoff using the A3000 data in the stated paragraphs.

In accordance with Para 6.11.1 of Chapter 6 "ATM Peculiarities, Flights in Special Conditions or Special Occurrences in Flight", in case "after the takeoff clearance is issued a departure controller detects (visually or by A-SMGCS A3000 indicator) runway incursion or inevitability thereof, ..., that can create safety hazard to the departing or landing aircraft", the ATC controller, among other actions, shall prohibit takeoff of the departing aircraft (if the aircraft has not started the takeoff roll) or inform the crew of the taking off aircraft on the safety hazard (if the aircraft has started the roll). Thus, this paragraph provides for the use of A3000 system even after the takeoff clearance has been issued, though it does not contain direct guidance thereof. Further, a section of the departure controller's working instruction describing actions when aircraft are landing, after having reported to the Landing Controller "Runway vacated", requires monitoring the runway within the visibility range or using the A-SMGCS A3000 system.

Note:

Departure controller's job description.

5.3 Peculiarities of arriving aircraft ATC.

5.3.2 As the aircraft is approaching:

ATC controller, ATS controller shall:

- monitor the runway within the visibility range or using the A-SMGCS A3000 system and listen to the radio exchange between the Landing Controller and the aircrew.

In accordance with Para 7.1, Section 7 "Runway occupied control procedure" of the Working Instruction of Departure Controller, absence of obstacles on the airstrip is determined from the working position of the departure controller visually (within visibility range) and with use of data from A-SMGCS A3000 as well as using reports provided by aircrews, and accountable person for the airstrip servicing.

Thus, documents regulating the work of the departure controller prescribe that they shall, regardless of the time of the day and weather conditions, provide mandatory monitoring of the taking off aircraft. In the first place, visual observation is meant under monitoring, as in case the controller sees any sign of aircraft malfunction they shall immediately report to the aircrew. However, the use of A3000 system is not determined for takeoff, though it is meant that with its help the controller can get information on obstacles providing threat to the aircraft cleared for takeoff. The setting of alerts is not determined either, though one of them (runway incursion monitoring) was activated by the A3000 system right after the aircraft started the takeoff roll (as

it reached the speed of about 5 m/sec). This alert was not indicated on the departure controller's screen as the RIM mode was de-activated. According to the explanation of the trainee controller, she was monitoring the A3000 screen at the moment the aircraft started the takeoff roll, that is if the RIM alert mode had been activated, she could have noticed the appearance of pertinent messages (first on blue and then on amber background) accompanied with an aural alarm. In this case immediate information to the crew on the obstacle (as required by Para 6.11 of the Working Instruction) could have prevented the accident. On the other hand, the alert list on the departure controller's screen contained 82 unacknowledged alert messages.

The investigation team also noted a deficiency that did not affect the flight outcome, that the radio exchange between the controller and electrical and lighting service experts was conducted with violation of radio exchange rules prescribed by Technology of Coordination of Airdrome Service with Vnukovo ATC Center: instead of callsign "Light" they used callsign "Electrical".

Note: Technology of Coordination of Airdrome Service with Vnukovo ATC Center

11.6. For the radio exchange purposes the following callsigns are assigned to the various services and aerodrome vehicles:

- Light No. - electrical and lighting service.

Analysis of ATC shift Supervisor's Actions

According to the documents provided to the investigation team the ATC shift supervisor does not have a working instruction but only a job description with specified authority, responsibility and accountability. The job description also contains Working Flowcharts with standard operating procedures the ATC shift supervisor shall accomplish in various situations.

The documents determining the work of the ATC shift supervisor do not contain any instructions on checking, setting and using the A3000 system. Information on the actual settings of the A3000 system on the ATC shift supervisor's working position is provided in Section 1.8.2.1. In particular, the RIM (Runway Incursion Monitoring) alert mode was activated on the ATC shift supervisor's working position. The B8-01 Reserved Line was not activated.

One of the Working Flowcharts in the job description of the ATC shift supervisor determines his actions when operations are conducted on the airstrip. In particular, the ATC shift supervisor shall receive pertinent request from the airdrome service, inform the controllers on the location, procedure and time of the start and end of the operations, then give approval for their conduct and further act in accordance with the Technology of Coordination of Airdrome Service

with Vnukovo ATC Center. According to the information received from the ground controller, the ATC shift supervisor informed her on the operation of airdrome vehicles at TWY B8.

The job description of ATC shift supervisor (Para 2.51) defines that he shall control the vehicles departure after the operations are completed. Monitoring of the vehicles during the operations by the ATC shift supervisor is not required. However, Para 2.52 of the job description requires that the ATC shift supervisor shall prohibit operations on the maneuvering area in case of absence or loss of two-way radio communication between a controller and person in charge of the operations. On the day of the accident the ATC shift supervisor was not notified on loss of radio communication.

At 19:57:49, after the aircraft had started takeoff roll and the A3000 system had identified snowplow 3 as track number 2228, there was an alert message generated on the ATC shift supervisor's screen. The following indication was to appear on the screen: "19:57 runway incursion between 2191³⁸ and 2228³⁹." The message first should have appeared on the light blue background and then on the amber one (Figure 97 and Figure 98) accompanied with an aural alert.

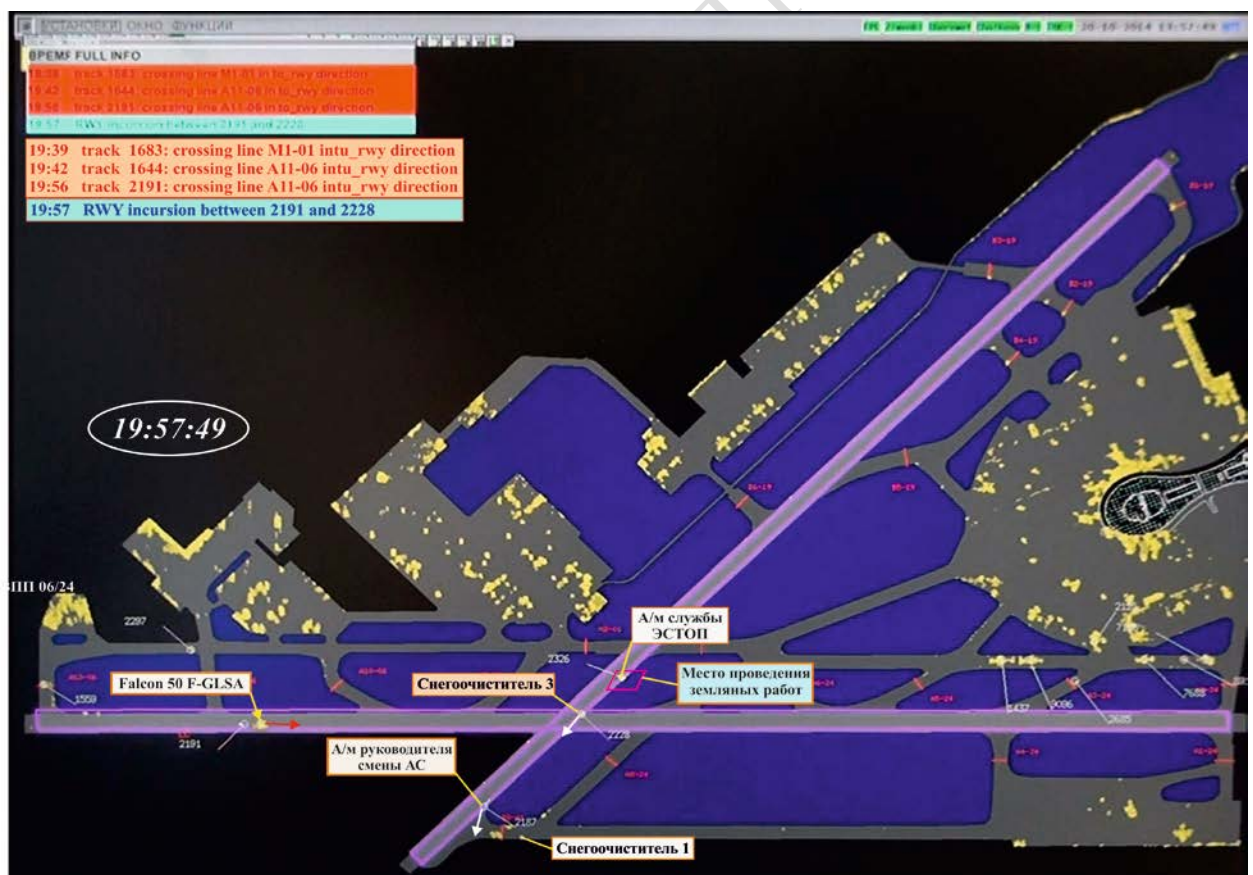

Figure 97 Location of objects at airdrome Vnukovo as viewed from the ATC shift supervisor's screen at 19:57:49

³⁸ Falcon 50EX F-GLSA aircraft.

³⁹ Snowplow 3.



Figure 98. Location of objects at the Vnukovo airdrome as viewed from the ATC shift supervisor's screen at 19:57:50

The investigation team notes that the screen of A3000 system installed on the ATC shift supervisor's working position was also used to display weather information (such combination is not provided by the system operations manual, the connection was done upon oral order of the management of Vnukovo ATC Center, See Section 1.18.1). When weather information is displayed, the information of the A3000 system is not shown. As the selection of screen and ATM room video monitor modes was not documented, and there were no clear explanations of the ATC shift supervisor, it was impossible to determine what was on the screen during the aircraft takeoff roll.

Note:

Extract from the interrogation of (name of ATC shift supervisor) as of 21.10.2014:

"I don't remember what picture was shown on the screen, either the airfield surveillance indicator or the weather radar".

Simultaneously a single oral alert (tone) was generated. The ATC shift supervisor's working position (personal computer) was not equipped with external speakers at the time of the accident. The output of sounds was made via built-in speakers of the computer system unit,

consequently the perception of the alert was significantly obstructed (low volume and short duration) by the sound of working equipment.

Note: *The investigation team notes that due to the short duration of the aural alert by default (no more than 0.1 sec) it can be left unnoticed even if a working position is equipped with good sound reproducing equipment. However, the format and/or duration of the alert can be modified by the A3000 subsystem's operator (see Section 1.8.2.1).*

It should be noted that as the archive video image on the ATC shift supervisor's screen was replayed it was revealed that from 19:42:10 to 19:57:49 there were 8 RIM alerts on the screen due to the "conflict" between the airdrome vehicles as they conducted operations at RWY 2 threshold and the electrical and lighting service car. At 19:43, as the aircraft with track number 1644 took off, an alert was generated on conflict with the electrical and lighting service car located in the earthwork area. There was no reaction from the ATC shift supervisor to those messages. This is evidence that the ATC shift supervisor did not actually operate the A3000 system.

After the alert appeared at 19:57:49 there were still 21 seconds left before the aircraft collision with the snowplow.

The job description of the ATC shift supervisor does not contain any recommendations as to his actions in that situation. However, from his working position the ATC shift supervisor is able to transmit at frequencies of the ground controller and departure controller, that is, in case he had identified the conflict, the ATC shift supervisor would have been able to warn the aircrew.

The investigation team notes that in violation of requirements of Para 2.37, Section 2 of the Job Description of the ATC Shift Supervisor, he did not make a record in the Log of Airfield Condition on having approved the time of the start and end of airfield operations.

Note: *Job Description of ATC Shift Supervisor.*

2. Responsibilities:

2.37. Receive information from airdrome service on airdrome condition, measured braking action and approve in written form the time of start and end of airdrome operations as well as bird information.

Record the approval in the Log of Airfield Condition.

Thus, the analysis performed by the investigation team allows concluding that the ATC controllers hardly used the information from A3000 system in their daily operations. The settings of the System on the ground controller and departure controller's working positions did not make it possible to get alerts on conflicting events. The messages generated by the System on the ATC shift supervisor's working position could not be displayed on the screen in case the weather radar information mode was selected. This modification was not provided by the operational manual of the A3000 system.

The mentioned deficiencies resulted from the inefficient arrangement of usage of the airfield surveillance and control subsystem A3000 by the Vnukovo ATC Center, first of all in terms of lack of personnel training on the use of the system.

However, according to the available data, there had been no voluntary reports from controllers to the Vnukovo ATC Center management on lack of knowledge and standard operating procedures to use the system. According to the analysis of SMS implementation at Vnukovo ATC Center (Section 1.18.6) for 2014, before the accident there had been no voluntary reports identifying hazards to flight safety at all. Considering the abovementioned accident circumstances and deficiencies in the ATM, lack of voluntary reports is evidence that this SMS element is not efficient. Line controllers, though being most aware on the safety hazards, did not become sources of information to identify and assess such hazards.

2.2.3. Flight Crew Status and Actions Analysis

When preparing for the flight, while on the stand, the crew listened to ATIS information Papa. Before the aircraft takeoff there were three more ATIS information transmissions: Quebec at 19:30, Romeo at 19:45 and Sierra at 19:47 that the crew did not listen to.

*Note: Information Papa, Quebec and Romeo were identical.
Information Sierra contained the following changes:
visibility 350 (instead of 550), RVR 900 (instead of 1400).*

The change of weather conditions did not hinder the flight. The crew took a justified decision to depart.

The crew actions during flight on the whole complied with the standard operating procedures.

When cleared for taxiing the ground controller cleared the aircraft for holding point at TWY A11 (not in the beginning of RWY 1) as TWY A13 located at the beginning of RWY 1 was closed for taxiing.

The information on TWY A13 closure was contained in Russian AIP and Instruction on Flight Operations in Vnukovo Airdrome terminal Area.

- Note:**
1. Russian AIP. 16 OCT 14. UUWW-41. WARNING: 2. TWY A12, A13, M2 (from TWY A13 to TWY C6) – are closed for taxiing of all ACFT types.
 2. Instruction on Flight Operations in Vnukovo Airdrome Terminal Area:
 - 2.3.15. Airdrome operation limitations:
 - 2.3.15.2. TWY A12, A13, M2 (from TWY A13 to TWY C6) – are closed for taxiing of all aircraft types.

The crew was also able to get information on the closure of TWY A13 when listening to ATIS information.

- Note:**
- Extract from the radio exchange transcript of the Falcon 50EX F-GLSA crew:
- «19:23:02.06 - 19:26:20.4. ATIS. Taxiway Alpha one three, taxiway Charlie four are out of operation, taxiway Mike three out of operation between taxiway Alpha two and taxiway Alpha five runway two out of operation between taxiway Mike two and runway two four".

The taxiing to the holding point was done by the PIC, judging by the extracts from the cockpit exchange:

- 19:54:26 PIC: "*J'en sais rien moi je suis le Follow Me*" ("I don't know I'm following the Follow Me");
- 19:54:47 PIC: "*Enfin moi je suis le Follow me pour l'instant mais tu sais ou on est?*" ("I mean I'm following the Follow Me so far, but do you know where we are?").

- Note:** As per design, nose wheel steering during taxiing operations on Falcon 50EX is only possible from the LH pilot seat.

The crew initiated takeoff along RWY 1 from TWY A11. The available takeoff distance was sufficient for safe takeoff.

According to the CVR record and design peculiarities of the aircraft, the PF at the start of the takeoff roll was the PIC, while the FO was the PM. It was the PIC who, while maintaining the takeoff direction and looking outside, noticed the snowplow 14 seconds after the start of the takeoff roll and said: "*What's the car crossing the road, eh?*". The investigation team concluded that the PIC detected exactly the snowplow 3 due to the fact that there were no other moving objects within the PIC's estimated visual range at that moment. Based on the available

information it was impossible to determine if the FO who was to monitor the instruments according to the SOP saw the snowplow 3 at that time.

Note: *However, as the crew were killed in the accident and there was no other evidence, the investigation team could not explicitly determine how the crew had perceived (interpreted) observing the mentioned object and what they observed (or did not observe) further on (until they noticed the snowplow again just before the collision) considering the night time and numerous runway and airfield lights.*

The speed of the aircraft and distance from the snowplow at the beginning of the phrase were 78 kt (145 km/h) and approximately 730 m respectively, and the end of the phrase being 85 kt (157 km/h) and approximately 660 m that is the actual RVR was consistent with the forecast and relatively good in that sector. The speed of snowplow 3 at the start of the phrase was about 14 km/h (Figure 74) (considering the delay between the actual detection and the uttering of the phrase, the speed of the snowplow at the moment it was detected was higher), it was moving perpendicular to the aircraft heading. The detection of the snowplow did not alert the crew, they continued taking off normally following the SOP. No report of the crew came to the ATC.

According to the information from Unijet, at the time of the accident the airline did not have recommendations for flight crews on actions when detecting obstacles on the runway in the course of the takeoff run before reaching V1. There were only recommendations for crews of Falcon 7x to reject takeoff at speeds from 80 knots to V1 in case they detect external threat. As explained by the airline, Flight Operation Manuals for crews of other aircraft types containing similar provisions "were being printed at the time of the accident".

However, even in the absence of explicit mention in the SOP, the expected behavior of a crew when detecting an obstacle on the runway is to abort the takeoff. This behavior is taught as of basic training.

At 19:58:00, after reaching the speed of 80 knots (starting from this speed effective yaw control is possible by applying rudder) the crew exercised transfer of control (this procedure is prescribed by the airline's SOP). The FO, being the PF, in accordance with the SOP uttered: «*My control*». At the time of the control transfer the snowplow had already stopped which could have prevented the FO from detecting it visually (at night time, with numerous runway lights, the strobe lights of the standing snowplow are less prominent than those of the moving one), provided he (the FO) had not probably seen it previously. The PIC from that moment was to start monitoring the instruments. Thus, the transfer of control from the PIC to the FO in the course of

the takeoff due to the design peculiarities of the Falcon 50EX (control of the nose landing gear is only possible from the LH pilot seat) might have made it more complicated for the crew to assess the actual risk level and probably prevented them from deciding to abort takeoff. The simulation showed (Section 1.16.3) that if the crew had decided to terminate takeoff at that stage and used all braking means in accordance with the rejected takeoff procedure the accident could have been avoided. The aircraft would have either stopped before reaching the snowplow or its speed would have been low enough to make it possible to turn off and even in case of collision would have hardly led to that severe outcome.

Note: *The investigation team notes that transfer of control from one pilot to the other during an unstabilized stressful (considering high workload) flight phase leads to extra risks especially in case there are additional hazards (unfavourable weather conditions, etc.).*

The rotation was initiated by the crew after making a relative report at a speed of 119 kt, in compliance with the AFM recommendations. At first (before the phrase of the PIC confirming he detected the snowplow again, 3 seconds before the collision, at a distance of about 200 m) the pitch rate was almost the same as in the previous flight. After detecting the obstacle there was an additional nose up input to the control column, which led to the increase of true AOA up to 17.4° at the moment of the collision. This is less than the stall AOA for the takeoff aircraft configuration without ground proximity effect, which is 19.5°. The stall AOA with ground proximity effect had not been defined by the aircraft designer.

According to the designer's data, the actual rate of nose up control column deflection was less than the maximum rate demonstrated during flight tests. If the rate of control column nose up input was the same as demonstrated during the flight tests⁴⁰, the aircraft would have rotated about 100 m before. Thus, considering the actual height of the aircraft at the time of the collision, the aerodynamics of the aircraft (in case of earlier detection of the obstacle by the crew) could have made it possible to fly over the snowplow and prevent the accident.

Thus, the crew had certain information and possibilities to prevent the accident. However, all crew actions until the obstacle was detected again, is evidence that seeing the object did not alert them.

Note: *The investigation team does not assume that the crew's "go-minded" status made them continue the takeoff roll while being*

⁴⁰ This could have happened in case the crew had noticed the obstacle earlier.

convinced that there was a vehicle on the runway. It can only be assumed that the crew did not identify that the vehicle could still be on the runway.

The investigation team presumes that the psycho-emotional status of the crew might have influenced somehow the decisions taken under those circumstances.

The crew had had enough time for rest before the flight. The investigation team did not reveal any violations of the duty time limitations on the previous days.

The crew arrived at the aircraft about 14:30 (the flight was initially planned for 18:00), that is 5 hours and 30 minutes before the accident. The crew had spent all the pre-flight time in the aircraft.

In accordance with the European rules, effective at the time of the accident that had to be complied with by the operator, the time of waiting for the flight on board the aircraft was not regulated as such. The rules only regulated the daily flight time (not more than 13 hours) and duty time (not more than 190 hours within 28 consecutive days and not more than 60 hours within the 7 consecutive days), moreover, according to the operator's documents the flight time accounting starts 30 minutes before the planned time of departure.

However, the analysis of the cockpit communication revealed that the crew yearned to leave the airport as soon as possible and fly home.

The crew requested Delivery controller clearance to start the flight (at 19:33) even before the passenger arrived and the door was closed, and was instructed to make another request after they are completely ready for the flight.

Then there was a revealing conversation in the crew:

FO: "They already had our flight plan but we have to call them back (door closed) and passenger onboard";

PIC: "What happens?"

...

FO: "I even set up the toilet paper"

...

FO: "(illeg) when will we leave from this place?"

At 19:48 the FO contacted Delivery again to report they were ready for departure. This was preceded by the PIC saying: *"We can consider he is on board, he is in the van"*.

As per the information available, this was the first flight of the crew to Vnukovo AP. The investigation team notes that the crew was not well familiarized with the airdrome. Thus, when

requesting engine startup the crew did not give correct information to the ground controller on their position, naming stand 3 Bravo while actually being at Stand 24.

As the FO confirmed the taxiing route he mentioned TWY C2 instead of TWY C5 advised by the ground controller. The taxiing route could not pass via TWY C2. Only while taxiing the FO regained orientation and named the right TWY where the aircraft was taxiing following the Follow Me car, and then the crew discussed their position and further taxiing route again.

Probably that was the reason why the Taxiing checklist was accomplished with a delay. According to Part 135 of Falcon DA-50 Training Program the Taxiing checklist shall be completed before the holding point, while in fact it was completed while the aircraft was taxiing to line up.

The mentioned facts could have changed the psycho-emotional status of the crew, leading to a status when information (if not clear and unambiguous) that can prevent from completing the mission is unconsciously repressed (forced out) and not taken into consideration.

The airline's FOM did not envisage the crew actions in case they detect an object crossing the runway in the course of the takeoff.

Note: *Commercial aviation pilots in the Russian Federation regularly undergo psychological examinations, including the MMPI test. The experience of using the test outcomes within the framework of aircraft accident investigations has revealed that among experienced successful pilots there are often personalities who are very stress resistant in common (expected) conditions (that is in situations they have been trained for and have explicit documented recommendations of how to act therein). On the other hand, the mentioned personality type often have a low level of personal or situational anxiety as well as low level of intellectual flexibility in uncommon (unexpected) situations. If the situation is unclear or ambiguous (when there is no preset decision) an individual with the mentioned personality type will most likely (unconsciously, without due rational analysis) choose an option that would allow completing the mission (though with a certain level of risk) over the one that is supported by personal and/or situational anxiety but will prevent from completing the mission.*

There was no information provided to the investigation team if the crew had experienced similar cases in their flight experience. According to the rules effective in France, it is only in

exceptional cases that two objects can be authorized to be on the runway when one of them is cleared for takeoff. According to the explanation of the operator, when preparing to fly to unknown airdromes the crews shall pay special attention to the so-called hotspots including runway intersections.

During the risk assessment of runway incursion within the Operator's SMS this risk was considered minor, as there were only three events of the type, two of them being taxiway incursions. However, the operator has a number of measures in place to prevent accidents related to runway incursions.

- recurrent theoretical flight crew training on the issue (once in three years);
- recurrent practical training including go-around and terminated takeoff procedures in case of runway incursion (every year during the check ride);
- regular information published at the airline's web-site on similar cases occurring to other operators. There was also information published with the recommendations of the DGAC of France, EASA and Eurocontrol on prevention of similar accidents.

Considering the abovementioned, the investigation team believes that the crew could have been in a non-optimal psycho-emotional status caused by their desire to take off as soon as possible to fly home. Having received the clearance from the controller, that, for the crew, among other things, mean that the runway is clear, the crew did not pay proper attention to the detection of the "car crossing the road" while rolling towards the hotspot and did not take a decision to terminate the takeoff.

3. CONCLUSION

The accident involving Falcon 50EX F-GLSA aircraft occurred at nighttime under foggy conditions while it was taking off after cleared by the controller due to collision with the snowplow that executed runway incursion and stopped on the runway.

Most probably, the accident was caused by the combination of the following⁴¹ contributing factors:

- lack of guidance on loss of control over an airdrome vehicle and/or situational awareness on the airfield in pertinent documents defining the duties of airdrome service personnel (airdrome shift supervisor and vehicle drivers);

- insufficient efficiency of risk mitigation measures to prevent runway incursions in terms of airdrome peculiarities that is two intersecting runways;

- lack of proper supervision from the airdrome service shift supervisor, alcohol detected in his organism, over the airfield operations: no report to the ATM or request to the snowplow driver as he lost visual contact with the snowplow;

- violation by the airdrome service shift supervisor of the procedure for airdrome vehicles operations, their entering the runway (RWY 2) out of operation (closed for takeoff and landing operations) without requesting and receiving clearance from the ground controller;

- violations by the medical personnel of Vnukovo AP of vehicle driver medical check requirements by performing formally (only exterior assessment) the mandatory medical check of drivers after the duty, which significantly increased the risk of drivers consuming alcohol during the duty. The measures and controls applied at Vnukovo Airport to mitigate the risk of airdrome drivers doing their duties under the influence of alcohol were not effective enough;

- no possibility for the snowplow drivers engaged in airfield operations (due to lack of pertinent equipment on the airdrome vehicles) to continuously listen to the radio exchange at the Departure Control frequency, which does not comply with the Interaction Procedure of the Airdrome Service with Vnukovo ATC Center.

- loss of situational awareness by the snowplow driver, alcohol detected in his organism, while performing airfield operations that led to runway incursion and stop on the runway in use. His failure to contact the airdrome service shift supervisor or ATC controllers after situational awareness was lost;

⁴¹ In accordance with the Manual of Aircraft Accident and Incident Investigation (ICAO Doc. 9756 AN/965), the factors are given in the logical sequence, without priority assessment. The identification of contributing factors is not to apportion blame or liability.

- ineffective procedures that resulted in insufficiently trained personnel using the airfield surveillance and control subsystem A3000 of A-SMGCS at the Vnukovo ATC Center, for air traffic management;

- no recommendation in the SOP of ATM personnel of Vnukovo ATC Center on how to set up the airfield surveillance and control subsystem A3000, including activation and de-activation of the Reserved Lines and alerts (as a result, all alerts were de-activated at the departure controller and ground controller's working positions) as well as how to operate the system including attention allocation techniques during aircraft takeoff and actions to deal with the subsystem messages and alerts;

- the porting of the screen second input of the A3000 A-SMGCS at the ATC shift supervisor WP for the display of the weather information that is not envisaged by the operational manual of the airfield surveillance and control subsystem. When weather information is selected to be displayed the radar data and the light alerts (which were present during the accident takeoff) become unavailable for the specialist that occupies the ATC shift supervisor's working position;

- the ATC shift supervisor's decision to join the sectors at working positions of Ground and Departure Control without considering the actual level of personnel training and possibilities for them to use the information of the airfield surveillance and control system (the criteria for joining of sectors are not defined in the Job Description of ATC shift supervisor, in particular it does not take into account the technical impossibility to change settings of the airfield surveillance and control system);

- failure by the ground controller to comply with the SOPs, by not taking actions to prevent the incursion of RWY 2 that was closed for takeoff and landing operations by the vehicles though having radar information and alert on the screen of the airfield surveillance and control system;

- failure by the out of staff instructor controller and trainee controller (providing ATM under the supervision of the instructor controller) to detect two runway incursions by the snowplow on the runway in use, including after the aircrew had been cleared to take off (as the clearance was given, the runway was clear), provided there was pertinent radar information on the screen of the airfield surveillance and control subsystem and as a result failure to inform the crew about the obstacle on the runway;

- lack of recommendations at the time of the accident in the Operator's (Unijet) FOM for flight crews on actions when external threats appear (e.g. foreign objects on the runway) during the takeoff;

- the crew failing to take measures to reject takeoff as soon as the Captain mentioned «*the car crossing the road*». No decision to abort takeoff might have been caused by probable non-optimal psycho-emotional status of the crew (the long wait for the departure at an unfamiliar airport and their desire to fly home as soon as possible), which might have made it difficult for them to assess the actual threat level as they noticed the snowplow⁴² after they had started the takeoff run;

- the design peculiarity of the Falcon 50EX aircraft (the nose wheel steering can only be controlled from the LH seat) resulting in necessity to transfer aircraft control at a high workload phase of the takeoff roll when the FO (seated right) performs the takeoff.

⁴² The investigation team concluded that it was exactly the snowplow that the PIC detected due to the fact that there were no other moving objects within the PIC's estimated visual range at that moment

4. SHORTCOMINGS

- 4.1. The ELT failed to activate during the accident. Despite the conducted examinations (Section 1.16.5) it was not possible to determine the cause of the ELT failure. During the subject accident the ELT failure did not affect the outcome, whereas under different circumstances it could bear significant impact on the survival aspects.
- 4.2. Vnukovo ATC Center personnel simulator training was organized and conducted with violation of the Provision on ATC Simulator Training Arrangement and Conduct for Personnel of State ATM Corporation:
 - 4.1.1. Some provisions of the arrangement and conduct of Vnukovo ATC Center personnel simulator training procedure (II-ГК-1616.07-1247) are not consistent with the requirements of the Provision on ATC Simulator Training Arrangement and Conduct for Personnel of State ATM Corporation (СТО-ГК-0001-045) and Supplement to Order № 93 of Russian Ministry of Transport as of 14.04.2010:
 - 4.1.2. The contents of training and checks plan in Supplement A is not consistent with the type form (reason for training is substituted by the objective);
 - 4.1.3. The contents of boxes in the Log of Simulator Training in Supplement B is not consistent with the type form (reason for training is substituted by the objective).
 - 4.1.4. "Synthesis TC-V" simulator training and check records were made with violations of the established procedure since June 2014 (numbers of training tasks were not recorded).
 - 4.3. The on-the-job training of the trainee controller was conducted with violation of regulations and corporate documents:
 - 4.3.1. In violation of Para 18, Supplement to Order № 93 of Russian Ministry of Transport, the practical training of the trainee controller was conducted without the on-the-job training plan;
 - 4.3.2. in violation of Para 7.1 Section 10 of the Provision on ATC Simulator Training Arrangement and Conduct for Personnel of State ATM Corporation, only 12 hours were scheduled for the simulator training and 2 hours for the simulator skill check instead of having complete simulator training to accomplish Tasks 1 to 4 (24 hours);
 - 4.3.3. no records were made of the date and time of the OJT sessions at the departure controller working station in the OJT log;
 - 4.3.4. there were no task and exercise number in the training assignments for Synthesis TC-V simulator, which violated the methodology of the trainee controller OJT training and decreased its quality and efficiency.
- 4.4. The following deficiencies were revealed in the ATM personnel individual logs:

- 4.4.1. The records of simulator training, theoretical and practical checks did not contain information on the name of the evaluator;
- 4.4.2. The records in the medical examination section were not consistent with the conclusion of the medical check;
- 4.4.3. Boxes in the various sections of the logs were filled in with violations of the applicable requirements;
- 4.4.4. There are no rules for ATC personnel individual log book maintenance, there are no responsible persons assigned for the maintenance of the ATM personnel individual logs.
- 4.5. In violation of FAR-216 of the Russian Ministry of Transport as of 26.11.2009, a Class 2 air traffic controller (instructor controller) was authorized to work as a out of staff instructor by order № 601 of Deputy Director for ATM of Moscow ATM Center, State ATM Corporation as of 01.09.2011.
- 4.6. Controllers of Vnukovo ATC Center, Moscow ATC Center, State ATM Corporation, airdrome service personnel of Vnukovo AP as well as drivers of Russia Special Flight Squadron when maintaining radio exchange violate the RTF rules and callsigns established by Para 11.6 of Technology on Coordination of Airdrome Service with the Vnukovo ATC Center and Other Ground Services at Vnukovo Airdrome and Para 7 of the Temporary Instruction on Aircraft Towing at Vnukovo Airdrome (introduced by Order № 146 of Vnukovo AP General Director as of 15.05.2007).
- 4.7. In violation of Para 2.1, Provision of Usage of Recording Devices and Data during ATM at Moscow ATC Center, State ATM Corporation (II-ГК-1601-250), 24/7 background recording and video monitoring of ATM working positions was not provided.
- 4.8. In violation of Flowchart 5 of the ATC Shift Supervisor's Job Description did not order the MAMC officer to make an unscheduled measuring of all weather elements being notified on the accident.
- 4.9. In violation of requirements of Para 2.37, Section 2 of the ATC Shift Supervisor's Job Description the ATC shift supervisor did not make a record in the Log of Airfield Condition on having approved the time of the start and end of airfield operations.
- 4.10. In violation of Para 4.1.2 of the Interaction Procedure of the Airdrome Service with the Vnukovo ATC Center, the coordination of operations between the ATC shift supervisor and the airdrome service shift supervisor was done without using the internal airdrome communications radio, telephones or intercom telephony.
- 4.11. In violation of Para 39 of Instruction 82 the airdrome shift supervisor did not report to the Tower controllers on the vehicle failure.

- 4.12. In violation of Supplement to Order № 93 of Russian Ministry of Transport, an ATC controller was authorized to work as a out of staff instructor controller by Order № 921 of Moscow ATC Center Director, State ATM Corporation as of 11.12.2012 without pertinent approval of the Russian CAA.
- 4.13. In violation of Para 45, Supplement to Order № 93 of Russian Ministry of Transport, duties of the ATC shift supervisor in April-May and June-August 2014 were delegated to chief shift 3 controller who had not passed the annual check for work as an ATC shift supervisor.
- 4.14. VIPPORT LTD, in violation of Para 4.1.1 Section ENR 1.10 and ENR 1.11 of the Aeronautical Information Publication (Russian AIP), Para 52.1 of FAR "Planning of Use of Airspace of Russian Federation" (approved by Order № 6 of the Russian Ministry of Transport as of 16.01.2012), Para 3.7.1 of FAR-293 did not submit to the ATM information on delay of the unscheduled LEA074P flight from Moscow Vnukovo to Paris Le Bourget of over 30 minutes.
- 4.15. In violation of Para 36 of Instruction 82, the Interaction Procedure of Airdrome Service with Vnukovo ATC Center did not contain the requirement to establish reference contact between the airdrome service shift supervisor and ATC every 15 minutes.
- 4.16. Incomplete weather information was provided to the Falcon 50EX F-GLSA crew by the VIPPORT LTD representatives.
- 4.17. The Falcon 50EX F-GLSA crew did not have current weather forecast and actual weather for the destination, alternate and en-route airdromes before the takeoff.
- 4.18. At the emergency and rescue station № 1 observation post, located at the area of RWY 2 departure (magnetic heading final = 13°) the observation of the RWY 2 portion at the landing area is obstructed as there is a structural frame at the observation sector, so that the observer is forced to move within the post during the duty.
- 4.19. At the revelation of the airdrome light element the respective report had not been drawn up.
- 4.20. In violation of Para 2.3.1 of PRAPI-98 there is no specific instruction on the actions, responsibilities and accountabilities of management personnel in case of an accident at Vnukovo ATC Center that shall be accepted by Central Territorial Office of Rosaviatsiya.
- 4.21. FAR-293 does not specify a procedure for monitoring that the runway is clear of foreign objects during the takeoff run and the landing roll.
- 4.22. There is inconsistency between the provisions of FAR-362 and Instruction № 82 in terms of fitting all airdrome vehicles involved in airfield operations with equipment to enable listening to the radio exchange at the Landing (Departure) Control frequency.

- 4.23. The form of the record of knowledge testing of airdrome vehicle and car drivers used during the seasonal training for autumn 2014/winter 2015 does not comply with the Manual on the Operation and Maintenance of Airdrome Vehicles at Airports of the Russian Federation enforced by Letter № 30/И of the Federal Aviation Service of Russia as of 07.04.1997.
- 4.24. There is no system in the Russian Federation for the planning and implementation of the SMGCS system. The implementation of the SMGCS is conducted in the course of its operation. No airdrome regulation contains a requirement that there shall be SMGCS system deployed at airdromes.

COURTESY ENGLISH TRANSLATION

5. SAFETY RECOMMENDATIONS

5.1. It is recommended that the Russian Aviation Authorities:

- 5.1.1. Communicate information on the accident to civil flight operations personnel, ATM personnel and airdrome service personnel.
- 5.1.2. Consider the practicability of developing additional measures to prevent runway incursions taking into account ICAO Doc 9870 AN/463 "Manual on the Prevention of Runway Incursions".
- 5.1.3. Consider the practicability of developing additional action plans to monitor that the runway is clear of foreign objects during takeoff run and landing roll.
- 5.1.4. Consider amending the aviation regulations to add a requirement of mandatory monitoring of ATC objects with the help of background recording and video monitoring of ATC working positions.
- 5.1.5. Consider mandating the check of airdrome vehicle drivers performing airfield operations for alcohol influence during the medical check before and after the duty shift. Introduce a standardized form of the medical check log for drivers of airdrome vehicles.
- 5.1.6. Conduct a re-assessment of ATC personnel working stations paying special attention to the field of view and mutual positioning of the screens providing necessary information to conduct the ATC.
- 5.1.7. Eliminate the contradiction between the provision of Para 1, Article 53 of the Air Code of the Russian Federation and Para 18, Section III of Order № 93 of the Russian Ministry of Transport as of 14.04.2010 in terms of the possibility of air traffic control being provided by trainee controllers not holding aviation personnel licenses.
- 5.1.8. Consider the practicability of introducing additions to FAR-262 in terms of mandating the marking of runway holding points at runway/runway intersections.
- 5.1.9. Bring the Instruction № 82 provisions into compliance with the ones of FAR-362 with regard to all the vehicles, performing works on the runway, to be equipped with the devices for the permanent listening to the radio exchange at the departure controller's frequency.
- 5.1.10. Clarify (improve) the training and authorization procedure for accredited instructors to be authorized to work as an out of staff ATC instructor.
- 5.1.11. Develop unified rules of ATC personnel individual log books maintenance.
- 5.1.12. Due to a big number of hazards identified as to the Vnukovo Airport and Vnukovo ATC Center airdrome service operations, consider conducting a re-assessment of pertinent risks and taking risk mitigation actions.

- 5.1.13. Develop technical specifications and operation procedures for the Surface Movement, Guidance and Control Systems (SMGCS).
- 5.1.14. Introduce requirements for the SMGCS system similar to those in Section 9.8 of ICAO Annex 14 Airdromes, Volume I and ICAO Doc 9476 and 9830 into the national aviation regulations on certification and operation of airdromes.
- 5.1.15. Ensure documentation and implementation within Airdrome Operators' SMS of a procedure to conduct medical checks (pre-duty and post-duty) as well as oversight during shifts to mitigate the risk of drivers doing their duties being under the influence of alcohol.
- 5.1.16. Consider the practicability of amending the applicable regulations to include a requirement to fit the airfield surveillance and control systems (in case they are installed at an airdrome) with MLAT/ADSB functions.

5.2. It is recommended that ATM State Corporation:

- 5.2.1. In cooperation with the Vnukovo ATC Center management arrange training for their personnel on the use of the airfield surveillance and control system A3000. Improve Working Instructions to include provisions on the recommended settings of the A3000 system depending on the working position as well as guidance on attention allocation while operating the system and reaction to various types of alerts. Consider the applicability of this recommendation to other ATC Centers where the same or similar system is used.
- 5.2.2. Consider revoking authorizations for work as out of staff instructors of ATC controllers issued with violation of Supplement to Order № 93 of Russian Ministry of Transport as of 14.04.2010.
- 5.2.3. Consider introducing standardized OJT logs for all ATC personnel for use during on-the-job probation training.
- 5.2.4. Maintain records of annual practical checks of instructor training for instructor controllers, both staff and out of staff ones, in the personal ATC controller log books.

5.3. It is recommended that the Moscow ATM Center of ATM State Corporation:

- 5.3.1. Take measures to prevent falsification of records in personnel documents. With regard to the previous recommendation, consider conducting an internal investigation on falsification of records in the individual log book and Log of Simulator Training on the simulator training of the instructor controller on the day of the accident (20.10.2014).
- 5.3.2. Consider revoking authorizations for work as instructors of ATC controllers authorized to be out of staff instructor controllers by orders № 601 by Moscow ATM Center of

State ATM Corporation as of 01.09.2011 № 921 as of 11.12.2012 № 4.1.1-08801 as of 17.08.2011.

5.4. It is recommended that the Vnukovo ATC Center of Moscow ATM Center, ATM State Corporation:

- 5.4.1. Improve its SMS taking into account the results of this investigation paying special attention to the functioning of the voluntary reporting system.
- 5.4.2. Develop a procedure for and accomplish the setting of Reserved Lines of the airfield surveillance and control system A3000 in the area of the big runway crossing. Assess the necessity of placing and/or correcting Reserved Lines in other locations.
- 5.4.3. Consider changing the format and duration of the sound alarm when various alert modes are activated to ensure a more attracting effect.
- 5.4.4. Arrange regular checks of ATC controllers in terms of efficiency of their operation of the airfield surveillance and control subsystem A3000 using readouts of the system's recorder.
- 5.4.5. Determine criteria to be used by the ATC shift supervisor when deciding to join ATC sectors.
- 5.4.6. Ensure compliance of radio exchange and reference radio communication by the Tower ATC units with the Coordination Procedure of Airdrome Service with Vnukovo ATC Center and Other Ground Support Services at Vnukovo Airdrome.
- 5.4.7. Ensure compliance of background recording and video monitoring of ATM working positions at Moscow ATM Center of State ATM Corporation with the Provision of Usage of Recording Devices and Data during ATM at Moscow ATC Center, State ATM Corporation (П-ГК-1601-250).
- 5.4.8. Ensure compliance of ATM personnel simulator training with Order № 182 of State ATM Corporation as of 16.04.2014.
- 5.4.9. In cooperation with MAMC, ensure automatic notification of the meteorologist of the main observation post upon the Emergency Landing (Alarm) signal.
- 5.4.10. Ensure terminology used in the Job Description of ATC Shift Supervisor of Vnukovo ATC Center (ДИ-ГК-1616.01-683) complies with the pertinent regulations.
- 5.4.11. Conduct training for ATM personnel on the usage of Terma Scanter 2001 Airfield Surveillance Radar and airfield surveillance and control subsystem A3000.
- 5.4.12. Consider clarifying the contents of exercises in Task 2 of the Arrangement and Conduct of Vnukovo ATC Center Personnel Simulator Training Procedure (П-ГК-1616.07-1247) to specify exercises to train personnel actions during runway and taxiway incursions.

5.4.13. Develop and enforce Instruction on Management Personnel Actions, Responsibilities and Accountabilities in Case of Accidents and have it accepted by the Central Territorial Office of Rosaviatsiya in compliance with Para 2.3 of PRAPI-98.

5.5. It is recommended that Vnukovo Airport, JSC⁴³:

- 5.5.1. Improve its SMS considering the investigation findings and take efficient measures to prevent runway incursions taking into account the peculiarity of the airdrome (two intersecting runways).
- 5.5.2. Ensure a check and, if required, provision of proper airdrome signage and marking prescribed by applicable regulations.
- 5.5.3. Ensure medical checks of airdrome vehicle drivers of Vnukovo AP are conducted in compliance with the requirements of the Instruction on Airdrome Vehicles Traffic Management at Vnukovo Airdrome before and after the duty shift.
- 5.5.4. Determine the actions of a person in charge of the airfield operations in case they lose visual contact with vehicles or in case of a vehicle failure.
- 5.5.5. Determine the actions of a vehicle driver in case they lose visual contact with the airfield operations supervisor or spatial orientation on the airfield.
- 5.5.6. Provide training for vehicle drivers on elements of airdrome lighting.
- 5.5.7. Consider the practicability of introducing qualification requirements as to English proficiency for airfield operations supervisors.
- 5.5.8. Require that reference radio communication is maintained by airdrome operations supervisors in accordance with the Interaction Procedure of Airdrome Service with Vnukovo ATC Center.
- 5.5.9. Revise the Interaction Procedure of Airdrome Service with Vnukovo ATC Center to add callsigns for all types of vehicles belonging to organizations operating on the airfield.
- 5.5.10. Bring the Interaction Procedure of Airdrome Service with Vnukovo ATC Center into compliance with the FAR-362 provisions with regard to all the vehicles, performing works on the runway, to be equipped with the devices for the permanent listening to the radio exchange at the departure controller's frequency.
- 5.5.11. Ensure compliance of the Interaction Procedure of Airdrome Service with Vnukovo ATC Center with the requirements of Para 36 of Instruction № 82 in terms of maintaining reference radio exchange.

⁴³ It is recommended that other Airport Operators of the Contracting States consider the applicability of the recommendations with regard to the actual state of affairs.

- 5.5.12. Consider revising the procedure for radio communication for vehicles operating on runways to make it compliant with Para 4.2.6 of ICAO Doc 9870.
- 5.5.13. Ensure the observer at the departure search and rescue station at departure area of RWY 2 (01) when on duty should pay special attention to complying with the requirements of Para 8 of the Instruction for Search and Rescue Station Observer as of 12.07.2012 in terms of taking a place at the observation post that ensures uninterrupted visual observation of aircraft takeoff and landing.
- 5.5.14. Ensure the radio exchange between the airdrome service dispatcher, airdrome service shift supervisors and vehicle drivers conducting airfield operations is recorded.

5.6. It is recommended that VIPPORT LTD:

- 5.6.1. Ensure timely provision of meteorological information to aircraft crews in accordance with the regulations.
- 5.6.2. Ensure the rectification of the raised findings including reporting to pertinent services in case the departure time is postponed.

5.7. It is recommended that Unijet:

- 5.7.1. Consider the practicability of improving their SMS in terms of recommended crew actions in case they detect an obstacle on the runway during takeoff or landing.
- 5.7.2. Re-assess the risks of transfer of aircraft control during the takeoff roll when the FO is the PF on aircraft where nose wheel steering is only possible from the LH seat. If necessary amend the FOM accordingly.

5.8. It is recommended that EASA, IAC Aviation Register, Rosaviatsiya and other certification authorities:

- 5.9.1. Consider the practicability to make mandatory for newly certified airplane (as per CS-25, AR-25 or equivalent) the installation of a nose wheel steering accessible by each flight crew member at their duty position.

5.9. It is recommended that the International Civil Aviation Organization:

- 5.9.1. Consider the practicability of introducing additions to Standard 5.2.10.7 of ICAO Annex 14, Volume 1 Airdrome Design and Operations (Edition 6, July 2013) in terms of marking the runway holding point at the runway/runway intersection even if there are no standard taxiing routes passing through the location.