

REPORT MDC K0388  
REVISION "E"  
ISSUED: \_\_\_ 1996

# **MD-11 AIRPLANE CHARACTERISTICS FOR AIRPORT PLANNING**

OCTOBER 1990

To Whom It May Concern:

This document is intended for airport planning purposes.  
Specific aircraft performance and operational requirements are  
established by the airline that will use the airport under consideration.

Questions concerning the use of this document should be  
addressed to:

Airport Compatibility Group  
McDonnell Douglas  
3855 Lakewood Blvd.  
M/C 801-23  
Long Beach, CA 90846 USA

Tel. (310) 593-6497

FAX (310) 982-6713

**MCDONNELL DOUGLAS**  
**DOUGLAS AIRCRAFT COMPANY**



## CONTENTS

Section	Page
1.0 SCOPE .....	1-1
1.1 Purpose .....	1-1
1.2 Introduction .....	1-2
2.0 AIRPLANE DESCRIPTION .....	2-1
2.1 General Airplane Characteristics .....	2-1
2.2 General Airplane Dimensions .....	2-4
2.3 Ground Clearances .....	2-5
2.4 Interior Arrangements .....	2-6
2.5 Cabin Cross Section .....	2-12
2.6 Lower Compartment .....	2-17
2.7 Door Clearances .....	2-19
3.0 AIRPLANE PERFORMANCE .....	3-1
3.1 General Information .....	3-1
3.2 Payload-Range .....	3-2
3.3 FAR Takeoff Runway Length Requirements .....	3-10
3.4 FAR Landing Runway Length Requirements .....	3-16
4.0 GROUND MANEUVERING .....	4-1
4.1 General Information .....	4-1
4.2 Turning Radii, No Slip Angle .....	4-2
4.3 Minimum Turning Radaii .....	4-3
4.4 Visibility from Cockpit .....	4-4
4.5 Runway and Taxiway Turn Paths .....	4-5
4.6 Runway Holding Bay (Apron) .....	4-10
5.0 TERMINAL SERVICING .....	5-1
5.1 Airplane Servicing Arrangement (Typical) .....	5-1
5.2 Terminal Operations, Turnaround .....	5-4
5.3 Terminal Operations, En Route Station .....	5-5
5.4 Ground Service Connections .....	5-6
5.5 Engine Starting Pneumatic Requirements .....	5-8
5.6 Ground Pneumatic Power Requirements .....	5-10
5.7 Preconditioned Airflow Requirements .....	5-11
5.8 Ground Towing Requirements .....	5-12
6.0 OPERATING CONDITIONS .....	6-1
6.1 Jet Engine Exhaust Velocities and Temperatures .....	6-1
6.2 Airport and Community Noise .....	6-8

## CONTENTS (CONTINUED)

<b>Section</b>		<b>Page</b>
7.0	PAVEMENT DATA .....	7-1
7.1	General Information .....	7-1
7.2	Footprint .....	7-4
7.3	Maximum Pavement Loads .....	7-5
7.4	Landing Gear Loading on Pavement .....	7-6
7.5	Flexible Pavement Requirements .....	7-8
7.6	Flexible Pavement Requirements, LCN Conversion .....	7-10
7.7	Rigid Pavement Requirements .....	7-12
7.8	Rigid Pavement Requirements, LCN Conversion .....	7-14
7.9	ACN-PCN Reporting System .....	7-18
8.0	POSSIBLE MD-11 DERIVATIVE AIRPLANES .....	8-1
9.0	MD-11 SCALE DRAWINGS .....	9-1

## **1.0 SCOPE**

**1.1 Purpose**

**1.2 Introduction**

## **1.0 SCOPE**

### **1.1 Purpose**

This document provides, in a standardized format, airplane characteristics data for general airport planning. Since operational practices vary among airlines, specific data should be coordinated with the using airlines prior to facility design. Douglas Aircraft Company should be contacted for any additional information required.

Content of this document reflects the results of a coordinated effort by representatives of the following organizations:

- Aerospace Industries Association
- Airports Council International
- Air Transport Association of America
- International Air Transport Association

The airport planner may also want to consider the information presented in the “CTOL Transport Aircraft: Characteristics, Trends, and Growth Projections,” available from the US AIA, 1250 Eye St., Washington DC 20005, for long range planning needs. This document is updated periodically and represents the coordinated efforts of the following organizations regarding future aircraft growth trends:

- International Coordinating Council of Aerospace Industries Association
- Airports Council International
- Air Transport Association of America
- International Air Transport Association

## **1.2 Introduction**

This document conforms to NAS 3601. It provides Model MD-11 characteristics for airport operators, airlines, and engineering consultant organizations. Since airplane changes and available options may alter the information, the data presented herein must be regarded as subject to change. Similarly, for airplanes not yet certified, changes can be expected to occur.

For further information, contact:

McDonnell Douglas  
Attention: Airport Compatibility Group  
M/C 801-23  
3855 Lakewood Blvd.  
Long Beach, California, 90846-0001 USA

or

Telex: 674357  
FAX: (562) 982-6713

**REV E**

## **1.0 SCOPE**

### **1.1 Purpose**

This document provides, in a standardized format, airplane characteristics data for general airport planning. Since operational practices vary among airlines, specific data should be coordinated with the using airlines prior to facility design. Douglas Aircraft Company should be contacted for any additional information required.

Content of this document reflects the results of a coordinated effort by representatives of the following organizations:

- Aerospace Industries Association
- Airports Council International
- Air Transport Association of America
- International Air Transport Association

The airport planner may also want to consider the information presented in the “CTOL Transport Aircraft: Characteristics, Trends, and Growth Projections,” available from the US AIA, 1250 Eye St., Washington DC 20005, for long range planning needs. This document is updated periodically and represents the coordinated efforts of the following organizations regarding future aircraft growth trends:

- International Coordinating Council of Aerospace Industries Association
- Airports Council International
- Air Transport Association of America
- International Air Transport Association



## **1.2 Introduction**

This document conforms to NAS 3601. It provides Model MD-11 characteristics for airport operators, airlines, and engineering consultant organizations. Since airplane changes and available options may alter the information, the data presented herein must be regarded as subject to change. Similarly, for airplanes not yet certified, changes can be expected to occur.

For further information, contact:

McDonnell Douglas  
Attention: Airport Compatibility Group  
M/C 801-23  
3855 Lakewood Blvd.  
Long Beach, California, 90846-0001 USA

or

Telex: 674357  
FAX: (562) 982-6713

**REV E**

## **2.0 AIRPLANE DESCRIPTION**

**2.1 General Airplane Characteristics**

**2.2 General Airplane Dimensions**

**2.3 Ground Clearances**

**2.4 Interior Arrangements**

**2.5 Cabin Cross Section**

**2.6 Lower Compartment**

**2.7 Door Clearances**

## 2.0 AIRPLANE DESCRIPTION

### 2.1 General Airplane Characteristics — MD-11

Maximum Design Taxi Weight (MTW). Maximum weight for ground maneuvering as limited by aircraft strength (MTOW plus taxi fuel).

Maximum Design Landing Weight (MLW). Maximum weight for landing as limited by aircraft strength and airworthiness requirements.

Maximum Design Takeoff Weight (MTOW). Maximum weight for takeoff as limited by aircraft strength and airworthiness requirements. (This is the maximum weight at the start of the takeoff run.)

Operating Empty Weight (OEW). Weight of structure, power plant, furnishing, systems, unusable fuel and other unusable propulsion agents, and other items of equipment that are considered part of a particular airplane configuration. OEW also includes certain standard items, personnel, equipment, and supplies necessary for full operations, excluding usable fuel and payload.

Maximum Design Zero Fuel Weight (MZFW). Maximum weight allowed before usable fuel and other specified usable agents must be loaded in defined sections of the aircraft as limited by strength and airworthiness requirements.

Maximum Payload. Maximum design zero fuel weight minus operational empty weight.

Maximum Seating Capacity. The maximum number of passengers certified or anticipated for certification.

Maximum Cargo Volume. The maximum space available for cargo.

Usable Fuel. Fuel available for aircraft propulsion.

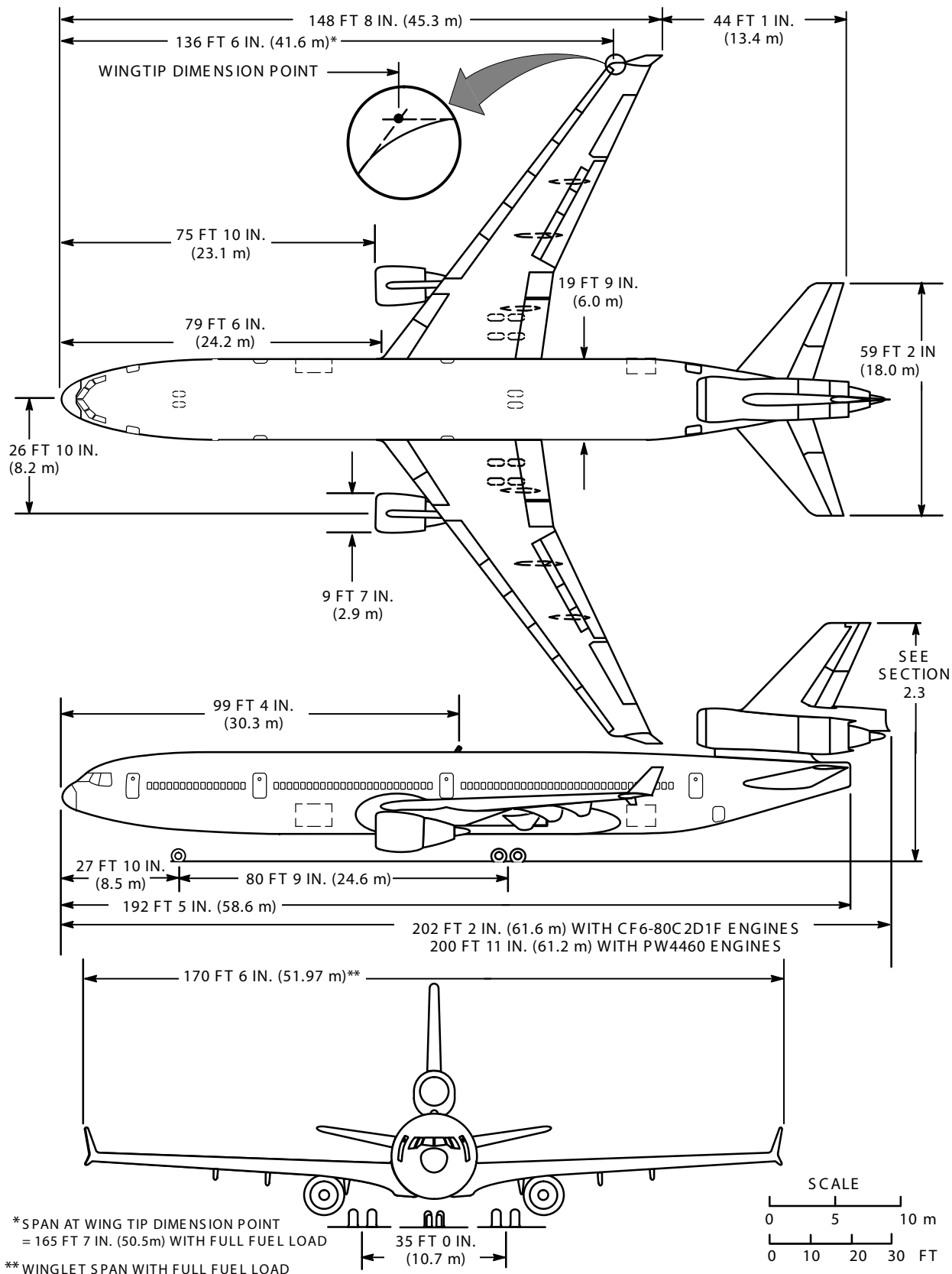

\* SPAN AT WING TIP DIMENSION POINT  
 = 165 FT 7 IN. (50.5m) WITH FULL FUEL LOAD

\*\* WINGLET SPAN WITH FULL FUEL LOAD

2.2 GENERAL AIRPLANE DIMENSIONS  
 MODEL MD-1

Chap2±Text  
 REV E

- MAXIMUM AND MINIMUM CLEARANCES OF INDIVIDUAL LOCATIONS ARE GIVEN FOR COMBINATIONS OF AIRPLANE LOADING/UNLOADING ACTIVITIES THAT PRODUCE THE GREATEST VARIATION AT EACH LOCATION. ZERO ROLL ANGLE AND LEVEL GROUND WERE ASSUMED FOR ANALYSIS.
- IT IS RECOMMENDED THAT APPROXIMATELY  $\pm 3$  INCHES (0.1 m) BE ALLOWED FOR VERTICAL EXCURSIONS DUE TO VARYING STRUT AND TIRE INFLATIONS, PAVEMENT UNEVENNESS, ETC.

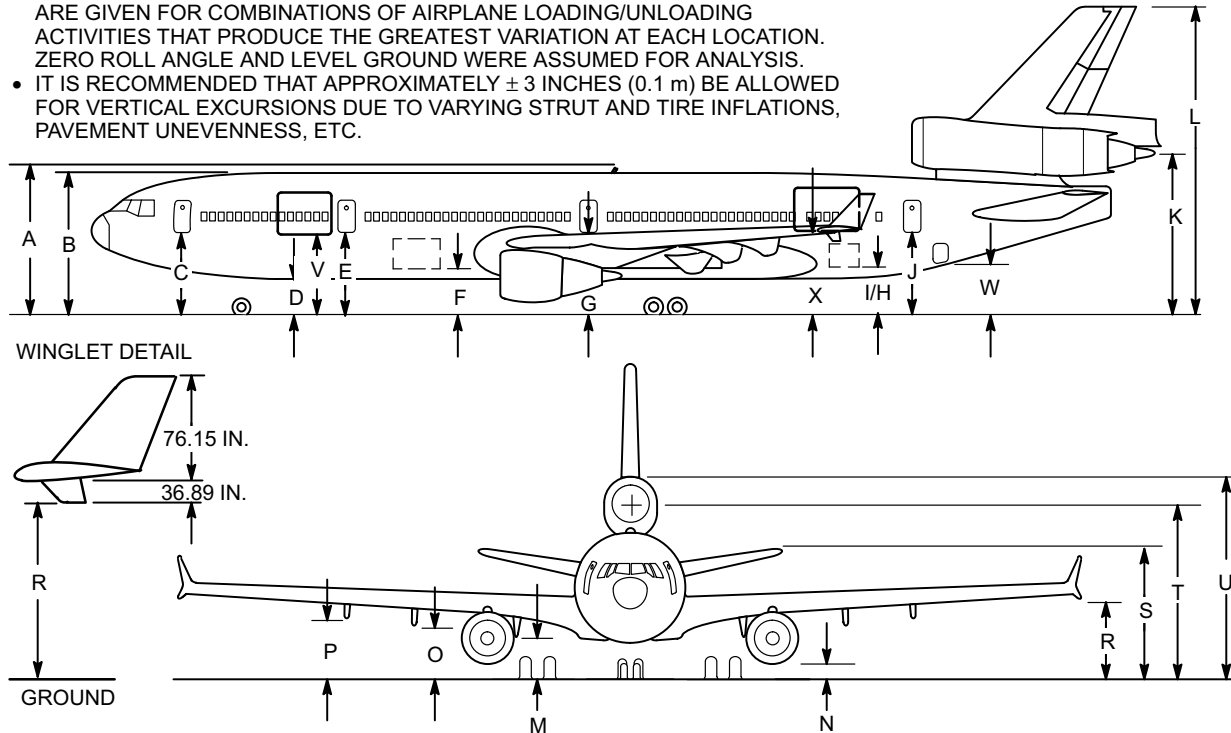

VERTICAL CLEARANCE				
	MIN CLEARANCE CRITICAL WT AND CG		MAX CLEARANCE CRITICAL WT AND CG	
	FT - IN.	METERS	FT - IN.	METERS
A	28 - 5	8.66	29 - 2	8.88
B	27 - 1	8.27	28 - 6	8.69
C	15 - 9	4.81	17 - 5	5.31
D	7 - 4	2.23	8 - 9	2.67
E	15 - 8	4.78	16 - 11	5.16
F	9 - 2	2.80	10 - 3	3.14
G	15 - 7	4.75	16 - 3	4.96
H	8 - 8	2.64	9 - 9	2.96
I	8 - 8	2.64	9 - 9	2.96
J	15 - 0	4.57	16 - 3	4.94
K	28 - 8	8.73	30 - 9	9.38
L	56 - 9	17.31	58 - 10	17.93
M	7 - 10	2.38	8 - 5	2.57
N *	3 - 2	0.96	4 - 5	1.25
O	9 - 8	2.93	10 - 5	3.17
P	10 - 8	3.25	11 - 7	3.52
R	12 - 4	3.77	13 - 4	4.07
S	22 - 7	6.89	25 - 7	7.49
T	32 - 3	9.83	33 - 6	10.20
U	36 - 10	11.23	38 - 2	11.63
V	15 - 8	4.80	17 - 1	5.21
W	9 - 11	3.03	11 - 4	3.44
X	15 - 3	4.61	16 - 3	4.94

\* = GE CF6-80C2 D1F  
H = STANDARD CENTER CARGO DOOR

V = FREIGHTER  
I = COMBI CENTER CARGO DOOR  
X = COMBI MAIN DECK DOOR

DMC005-5

### 2.3 GROUND CLEARANCES MODEL MD-11

REV D

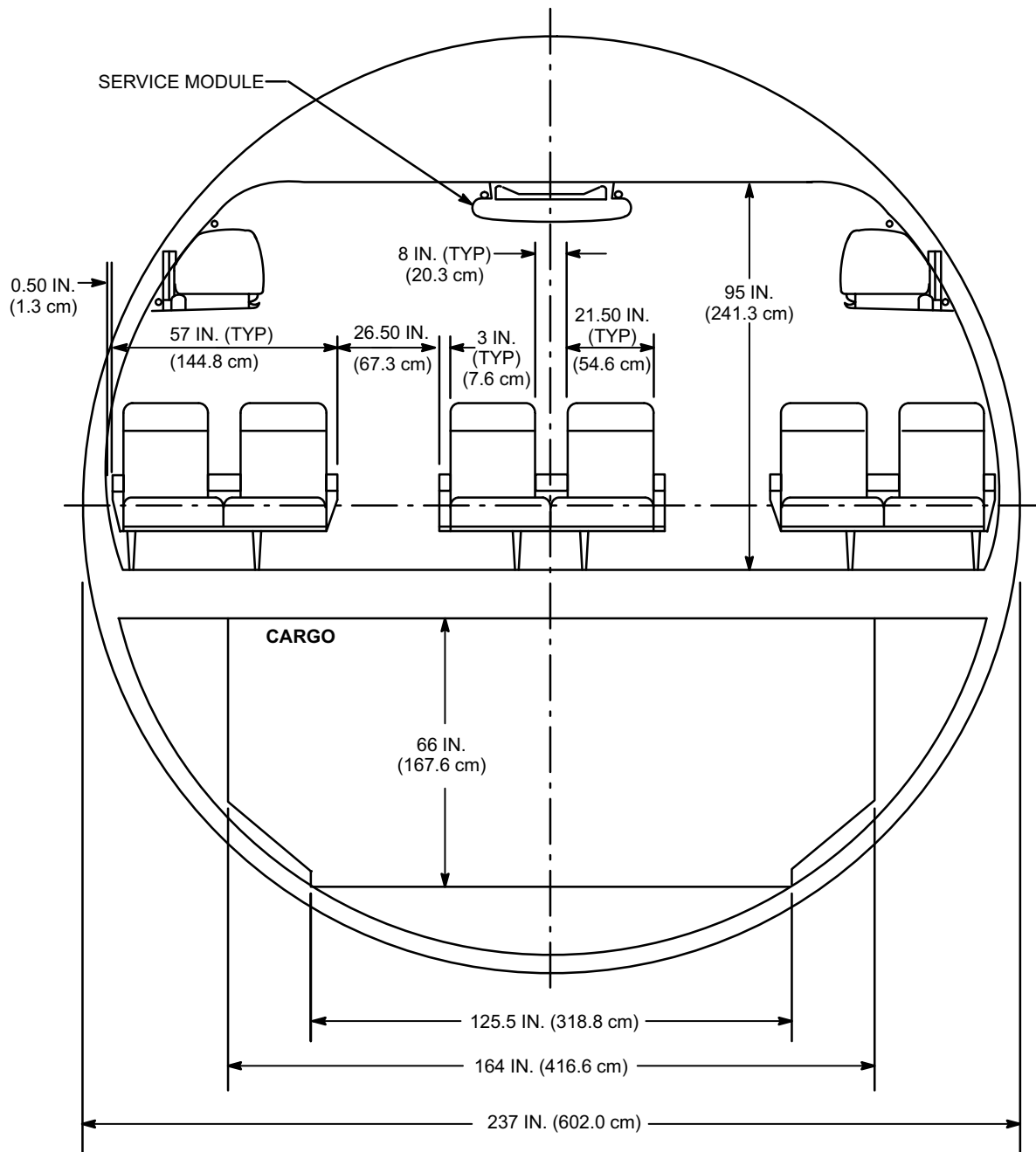

**2.5 CABIN CROSS SECTION  
2.5.1 FIRST CLASS  
MODEL MD-11**

REV E

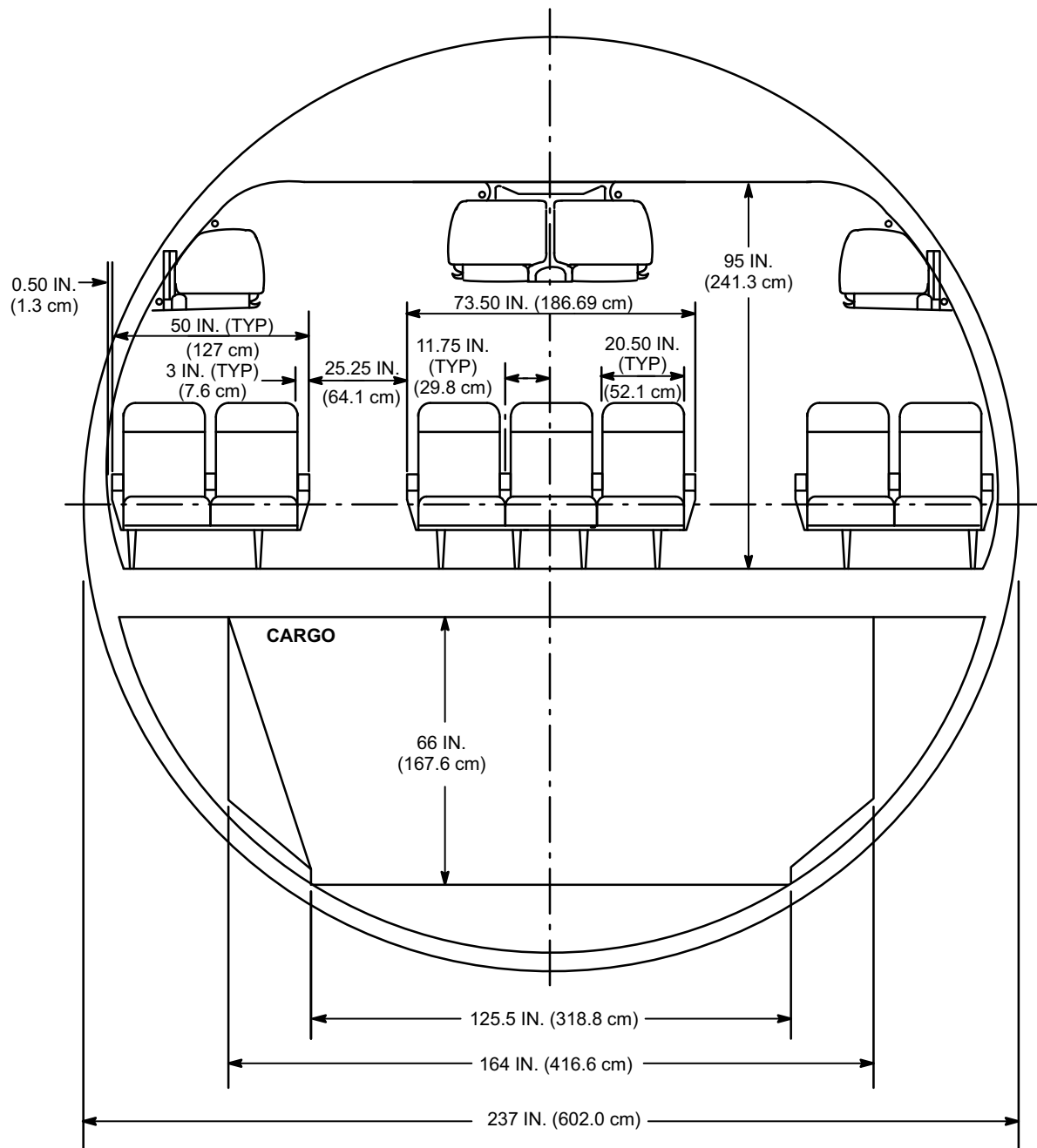

**2.5.2 BUSINESS CLASS  
MODEL MD-11**

REV E

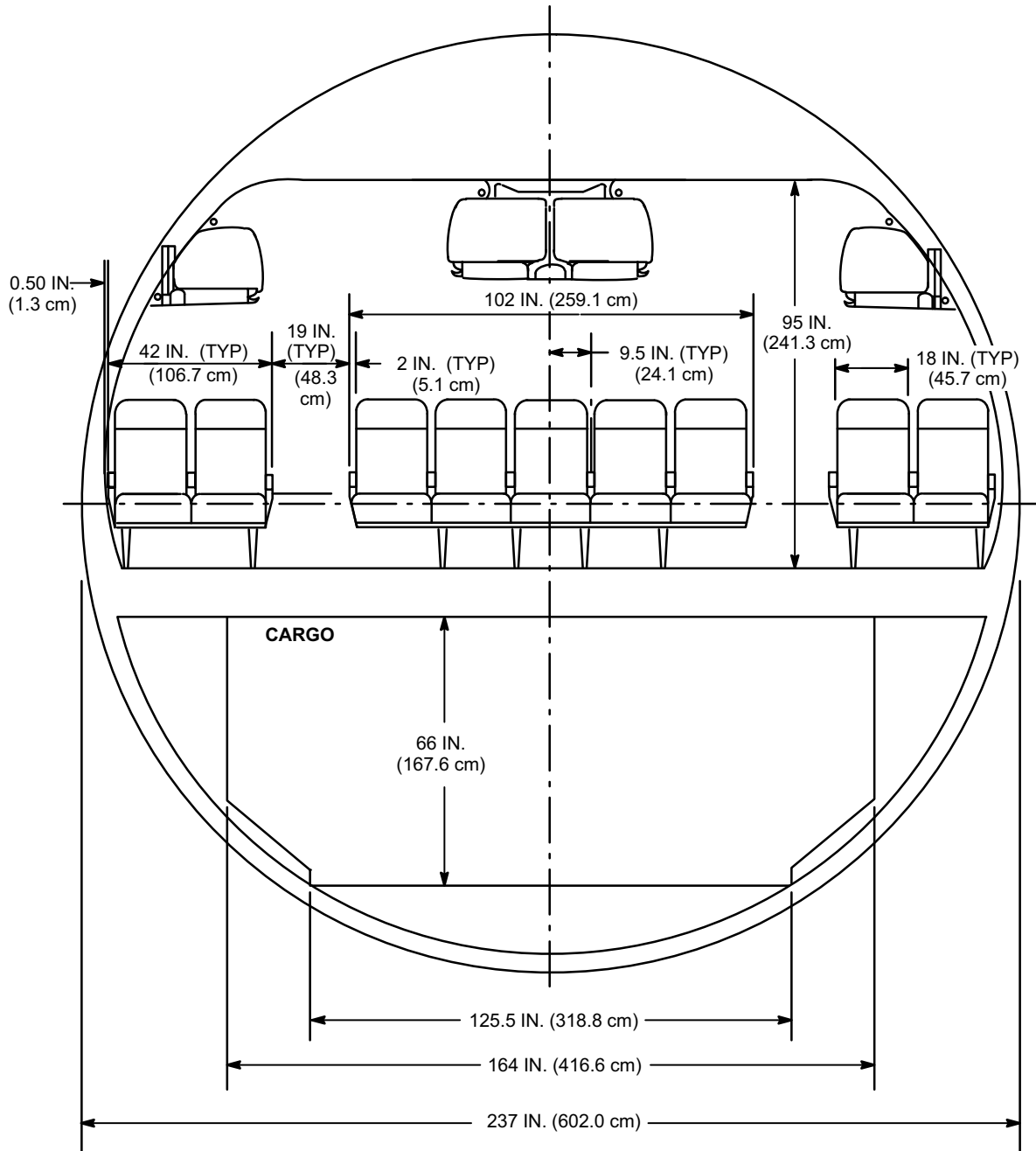

**2.5.3 ECONOMY  
MODEL MD-11**

REV E



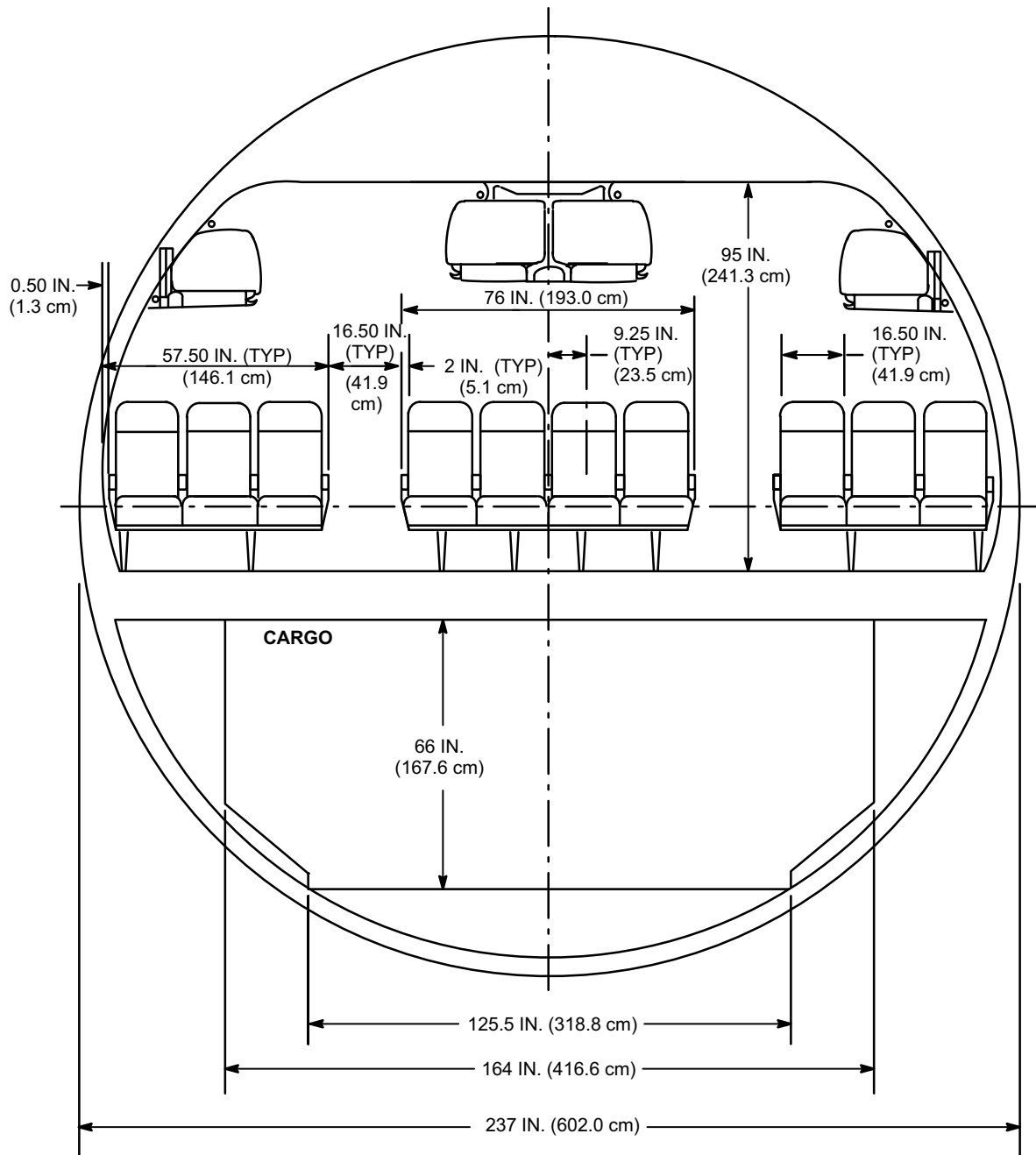

**2.5.4 HIGH-DENSITY  
MODEL MD-11**

REV E

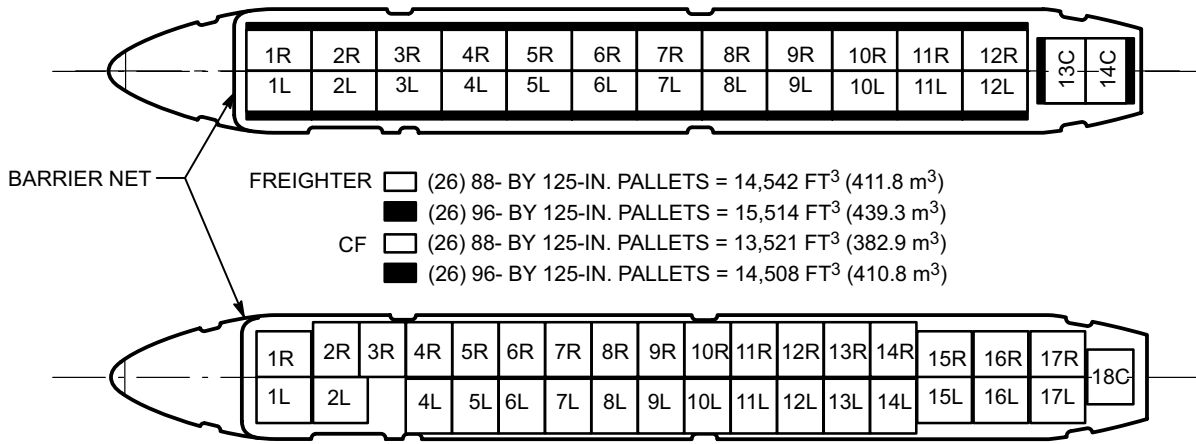

- FREIGHTER  (26) 88- BY 125-IN. PALLETS = 14,542 FT<sup>3</sup> (411.8 m<sup>3</sup>)
- (26) 96- BY 125-IN. PALLETS = 15,514 FT<sup>3</sup> (439.3 m<sup>3</sup>)
- CF  (26) 88- BY 125-IN. PALLETS = 13,521 FT<sup>3</sup> (382.9 m<sup>3</sup>)
- (26) 96- BY 125-IN. PALLETS = 14,508 FT<sup>3</sup> (410.8 m<sup>3</sup>)

FREIGHTER  (34) 88- BY 108-INCH PALLETS = 15,537 FT<sup>3</sup> (440.0 m<sup>3</sup>)

MAIN CARGO LOADED COMPARTMENT  
 LENGTH = 144 FT 4 IN. (44.0 m)  
 FLAT FLOOR AREA = 2,614.5 FT<sup>2</sup> (242.9 m<sup>2</sup>)  
 BULK VOLUME = 22,048 FT<sup>3</sup>\* (624.3 m<sup>3</sup>)

\* BULK VOLUME IS WATER VOLUME OF CABIN BETWEEN BARRIER NET AND AFT BULKHEAD

**TYPICAL CARGO SECTION**

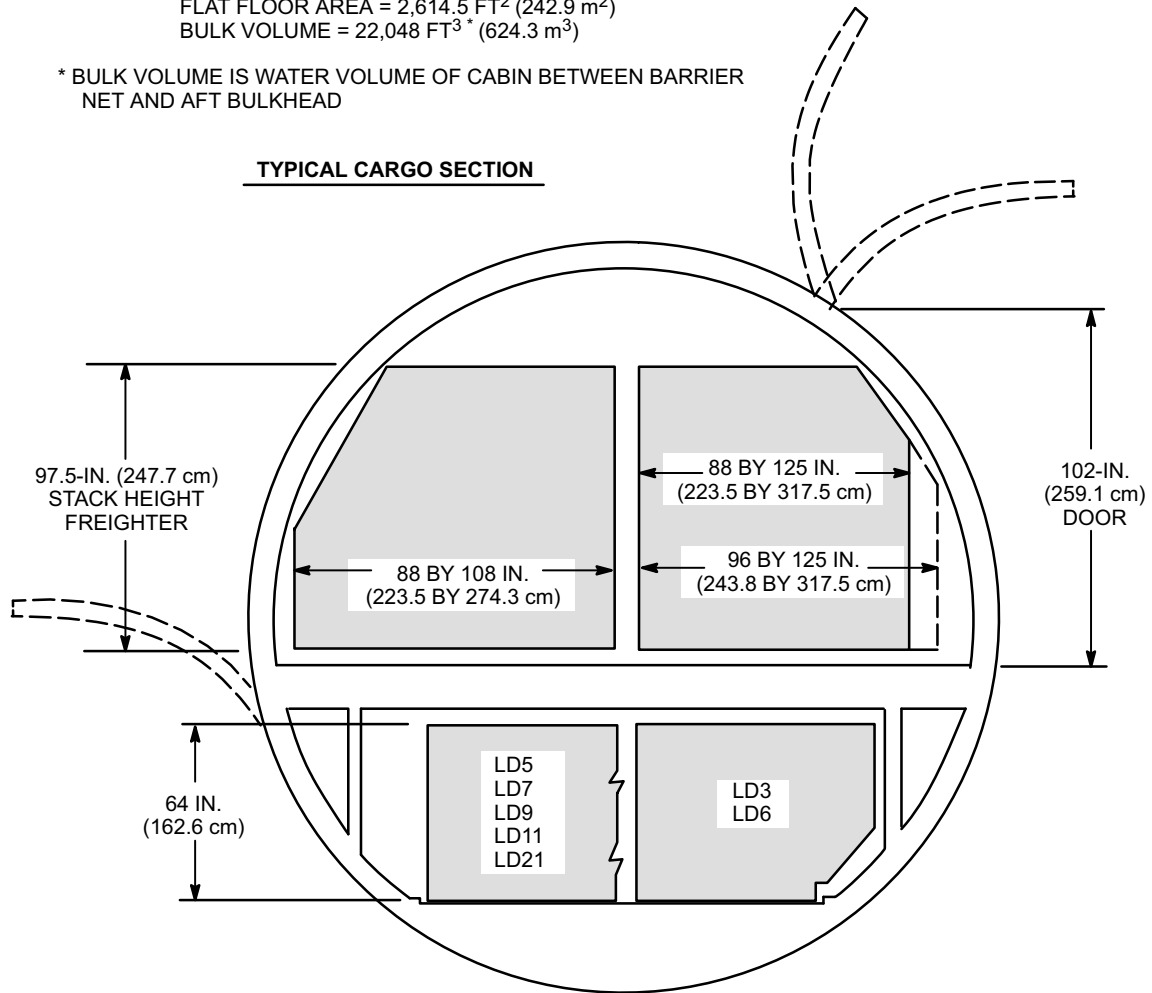

DMC005-15

**2.5.5 CROSS SECTION – CARGO  
 MODEL MD-11F/CF**

REV D

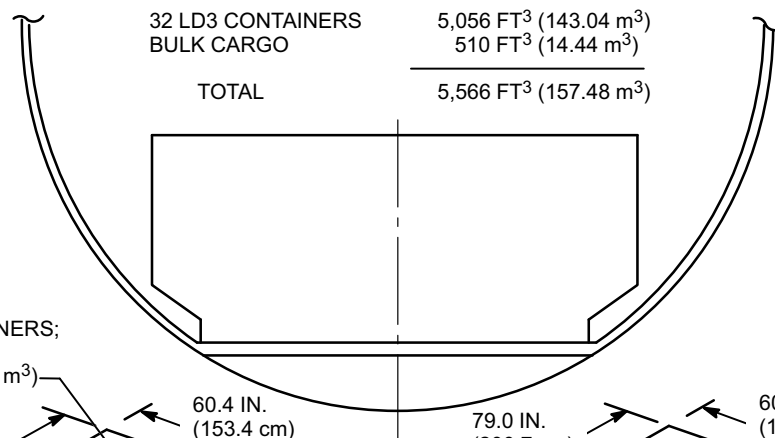
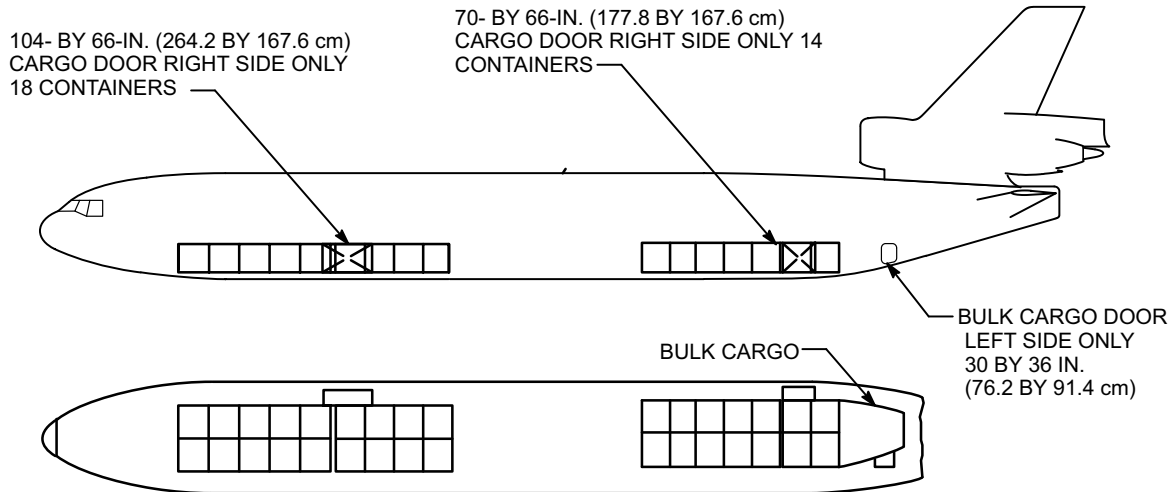

16 FULL WIDTH CONTAINERS;  
EACH 320 FT<sup>3</sup> (9.06 m<sup>3</sup>)  
TOTAL 5,120 FT<sup>3</sup> (144.96 m<sup>3</sup>)

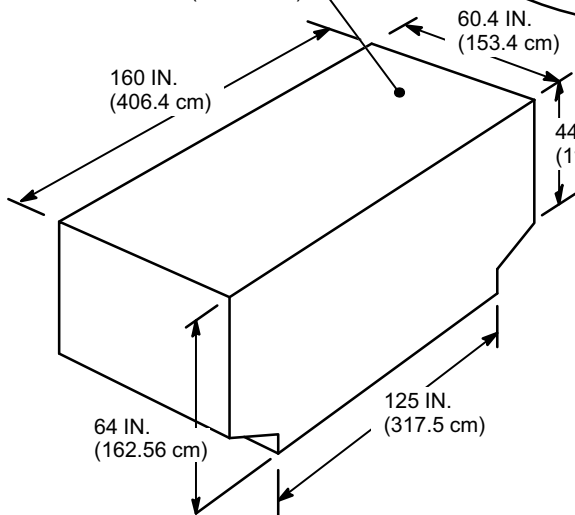

**LD6 CONTAINER**

<b>GROSS WEIGHT</b> 7,000 LB EACH (3,175 kg)	<b>TARE WEIGHT</b> 600 LB EACH (272.2 kg)
--	---

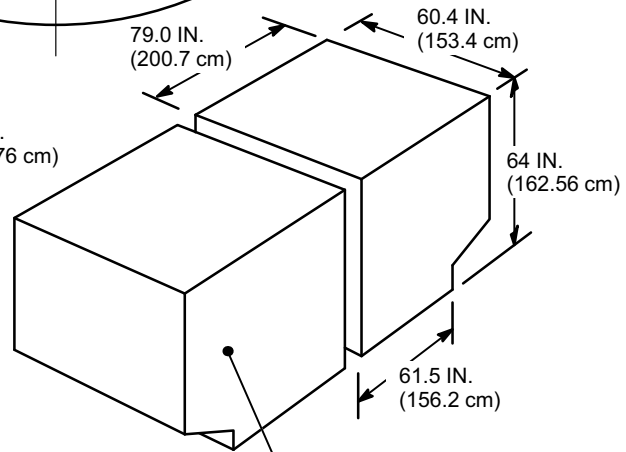

32 HALF WIDTH CONTAINERS;  
EACH 158 FT<sup>3</sup> (4.47 m<sup>3</sup>)  
TOTAL 5,056 FT<sup>3</sup> (143.04 m<sup>3</sup>)

**LD3 CONTAINER**

<b>GROSS WEIGHT</b> 3,500 LB EACH (1,588 kg)	<b>TARE WEIGHT</b> 320 LB EACH (145.1 kg)
--	---

**2.6 LOWER COMPARTMENT**  
**2.6.1 CARGO COMPARTMENTS – CONTAINERS**  
**MODEL MD-11**

DMC005-16

REV B

104- BY 66-IN. (264.2 BY 167.6 cm)  
CARGO DOOR RIGHT SIDE ONLY  
6 PALLETS

70- BY 66-IN. (177.8 BY 167.6 cm)  
OPTIONAL 104- BY 66-IN. (264.2 BY 167.6 cm)  
CARGO DOOR RIGHT SIDE ONLY  
14 CONTAINERS

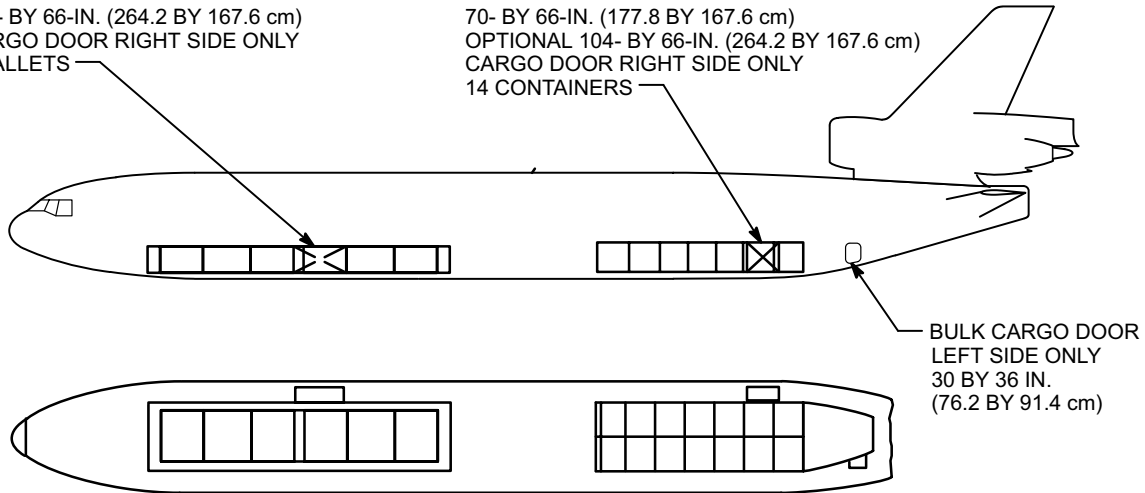

OR

6-96 BY 125 PALLETS	2,667 FT <sup>3</sup> (75.48 m <sup>3</sup> )
6-88 BY 125 PALLETS	2,268 FT <sup>3</sup> (64.20 m <sup>3</sup> )
14 LD3 CONTAINERS	2,212 FT <sup>3</sup> (62.58 m <sup>3</sup> )
BULK CARGO	510 FT <sup>3</sup> (14.44 m <sup>3</sup> )
<b>TOTAL</b>	<b>4,990 FT<sup>3</sup> (141.22 m<sup>3</sup>)</b>

6-96 BY 125-IN. PALLETS  
EACH 444 FT<sup>3</sup> (12.57 m<sup>3</sup>)  
TOTAL 2,664 FT<sup>3</sup> (75.41 m<sup>3</sup>)  
OR  
6-88 x 125 PALLETS  
EACH 378 FT<sup>3</sup> (10.70 m<sup>3</sup>)  
TOTAL 2,268 FT<sup>3</sup> (64.2 m<sup>3</sup>)

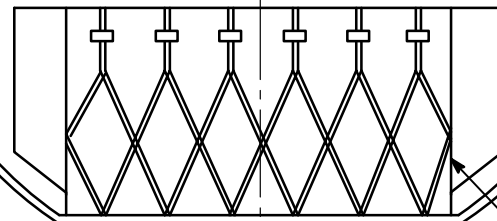

CONTAINERS  
CENTER COMPARTMENT

PALLETS  
FWD COMPARTMENT

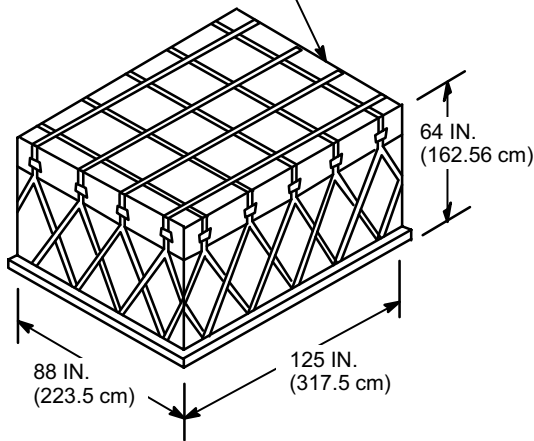

88 BY 125-IN. PALLET (223.5 BY 317.5 cm)

GROSS WEIGHT	TARE WEIGHT
10,300 LB EACH	248 LB EACH
(4,672 kg)	(113 kg)

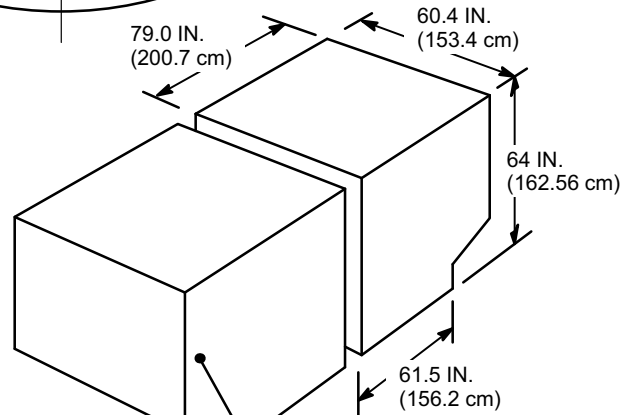

14 HALF WIDTH CONTAINERS; (LD3)  
EACH 158 FT<sup>3</sup> (4.47 m<sup>3</sup>)  
TOTAL 2,212 FT<sup>3</sup> (62.58 m<sup>3</sup>)

LD3 CONTAINER

GROSS WEIGHT	TARE WEIGHT
3,500 LB EACH	320 LB EACH
(1,588 kg)	(145.2 kg)

DMC005-17

## 2.6.2 CARGO COMPARTMENTS – CONTAINERS/PALLETS MODEL MD-11

REV D

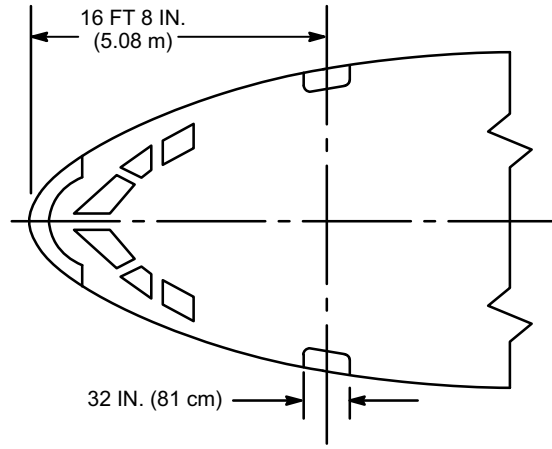

PLAN VIEW

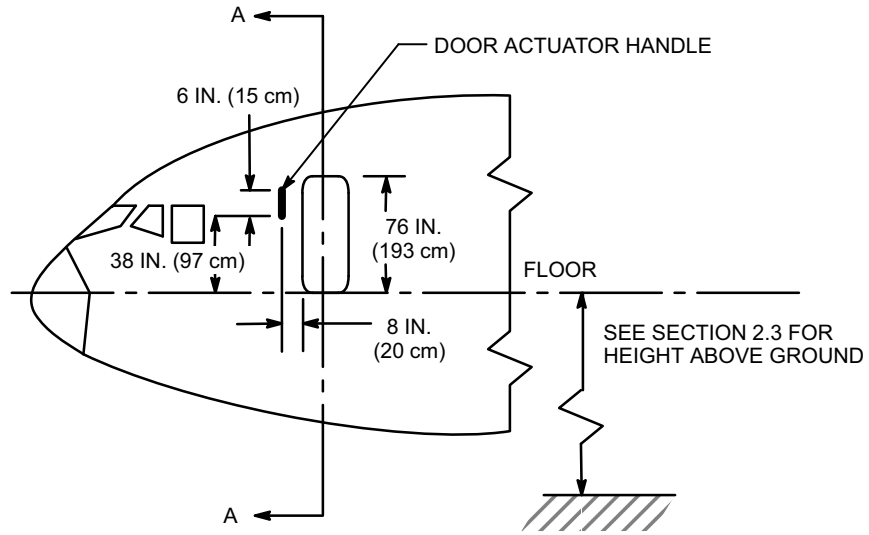

ELEVATION

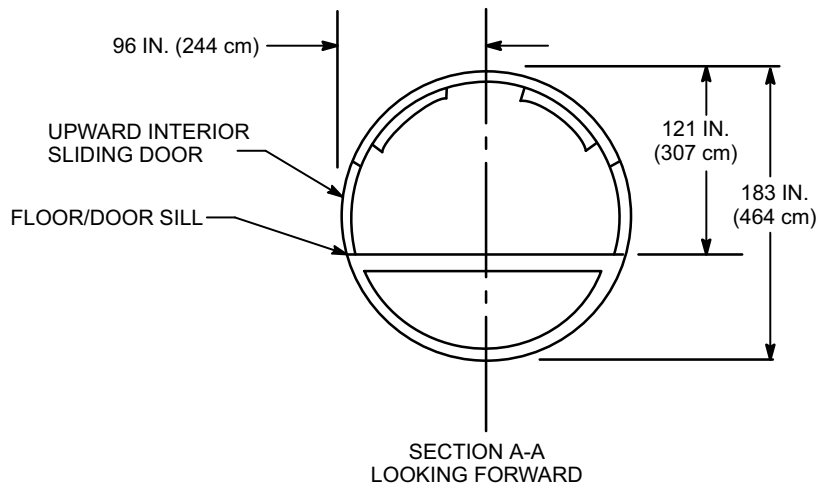

## 2.7 DOOR CLEARANCES

DMC005-18

### 2.7.1 CLEARANCES, PASSENGER LOADING DOORS, DOOR NO. 1 MODEL MD-11

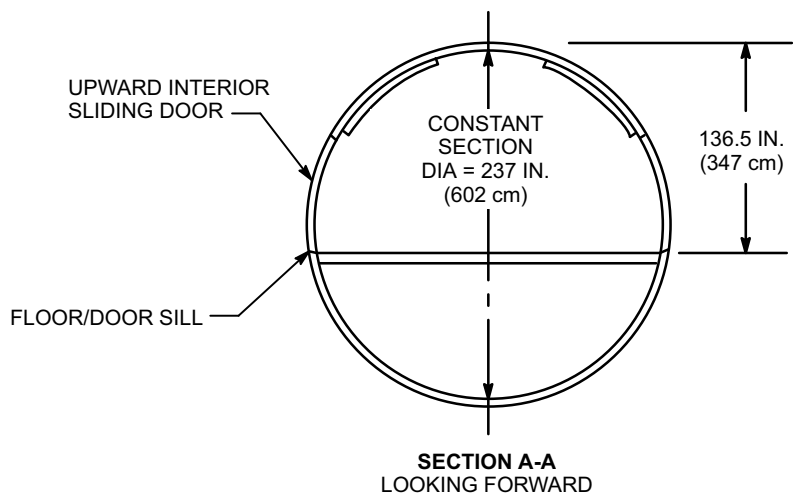
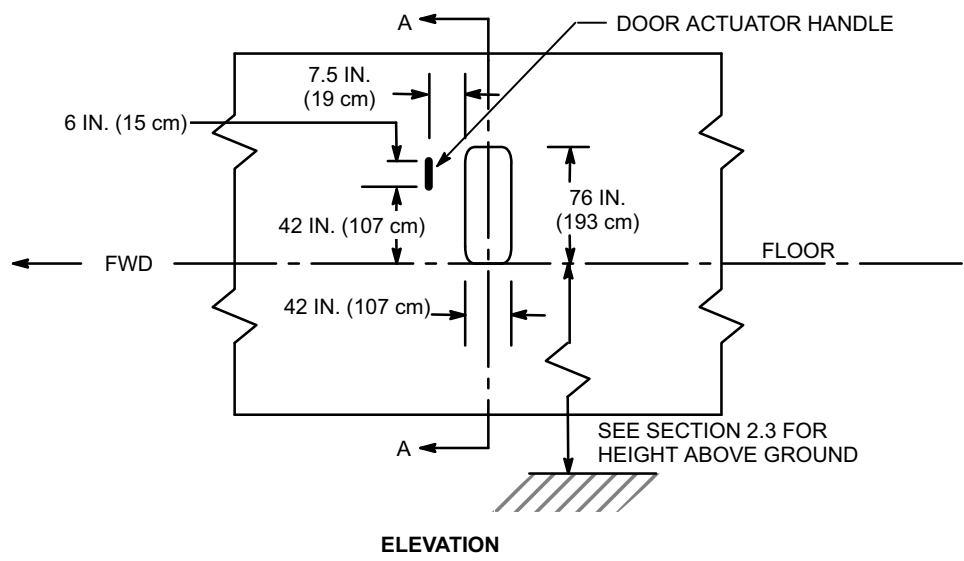
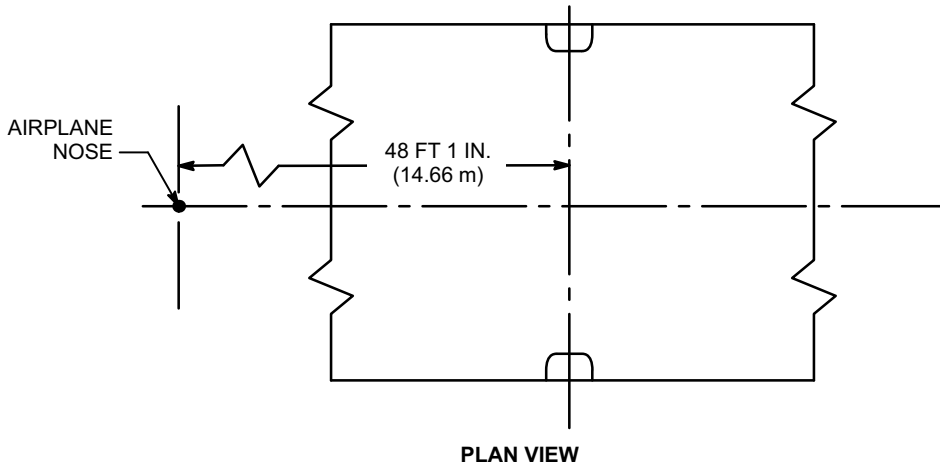

DMC005-19

**2.7.1 CLEARANCES, PASSENGER LOADING DOORS, DOOR NO. 2  
MODEL MD-11**

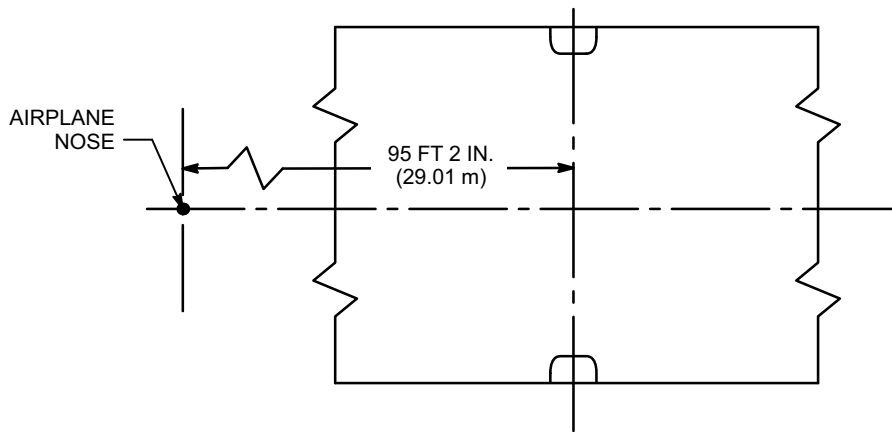

PLAN VIEW

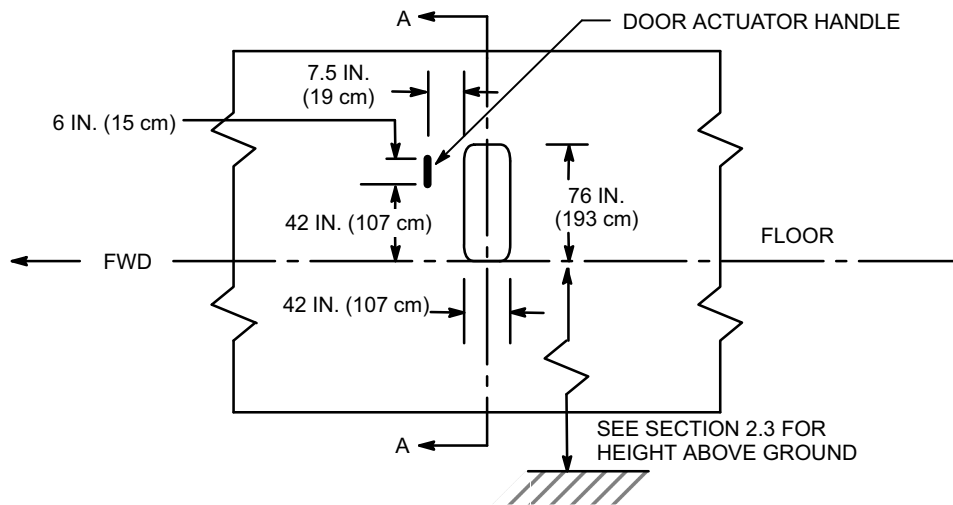

ELEVATION

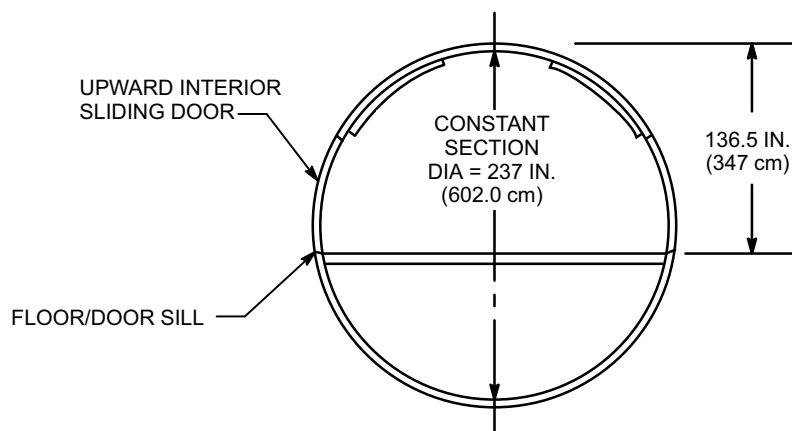

SECTION A-A  
LOOKING FORWARD

DMC005-20

**2.7.1 CLEARANCES, PASSENGER LOADING DOORS, DOOR NO. 3  
MODEL MD-11**

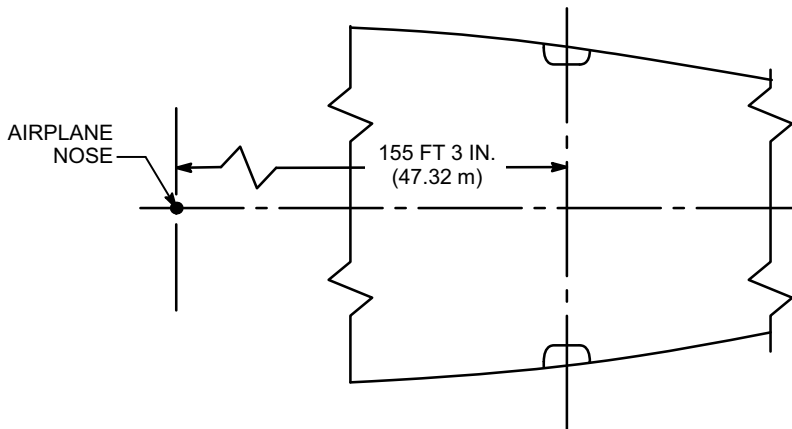

PLAN VIEW

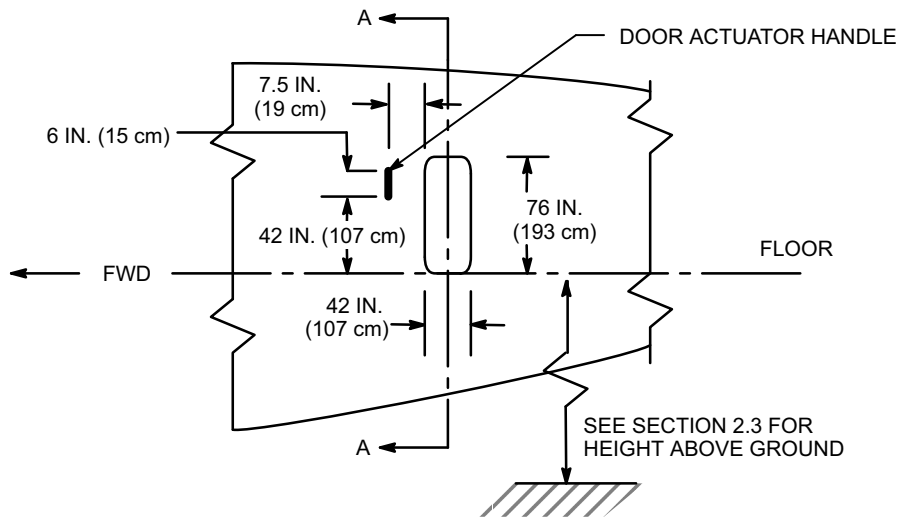

ELEVATION

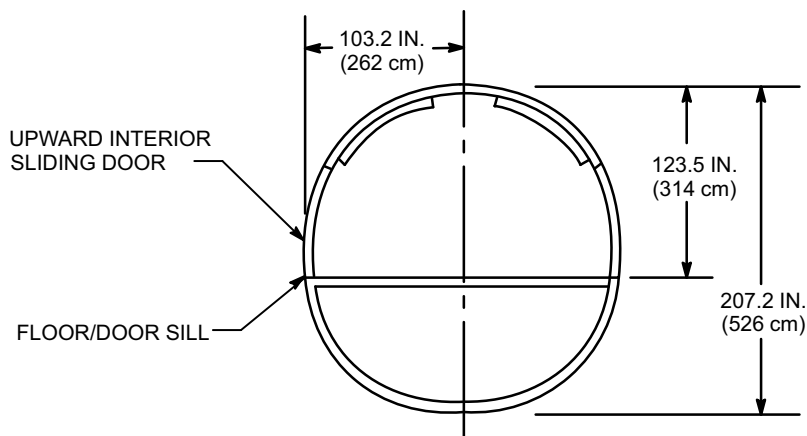

SECTION A-A  
LOOKING FORWARD

DMC005-21

**2.7.1 CLEARANCES, PASSENGER LOADING DOORS, DOOR NO. 4  
MODEL MD-11**



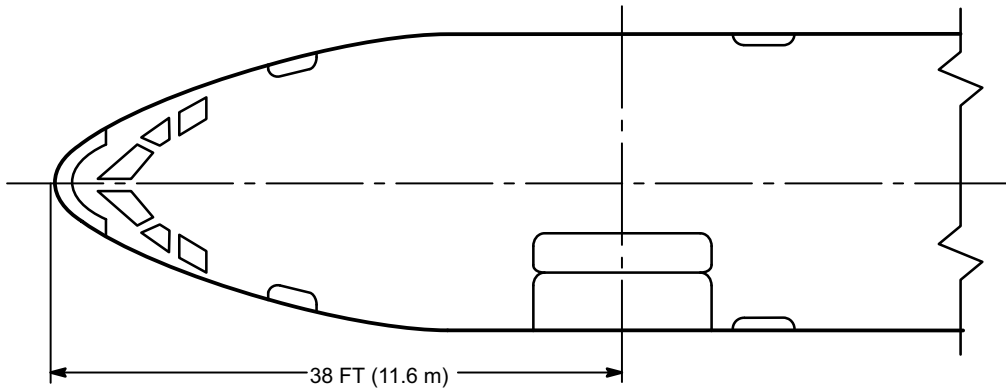

PLAN VIEW

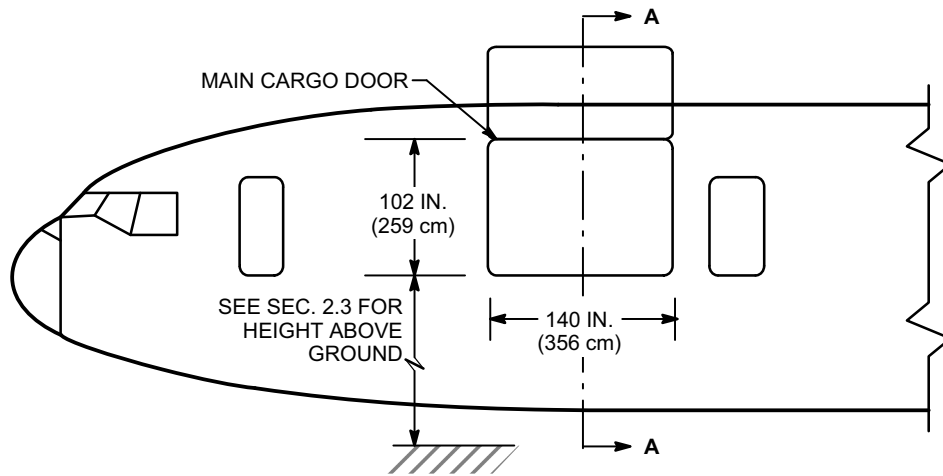

ELEVATION

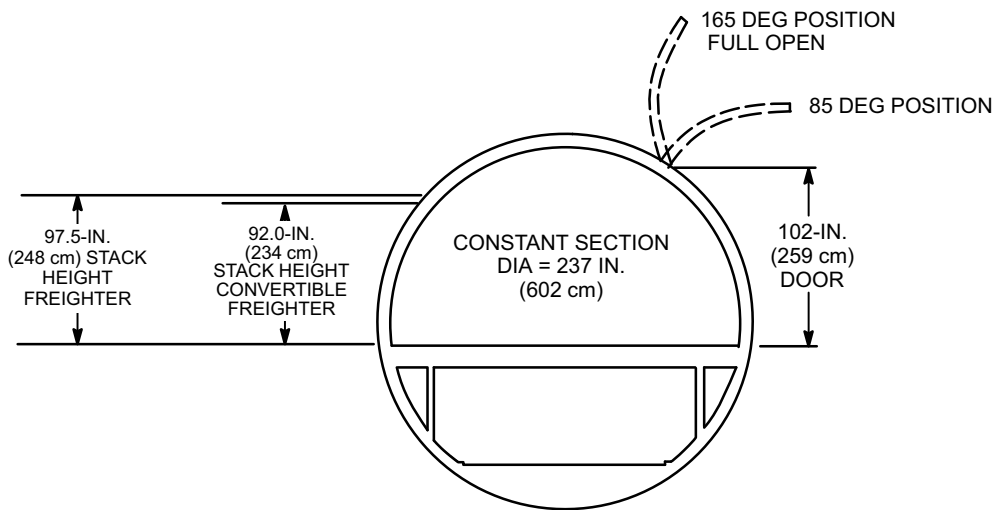

SECTION A-A  
LOOKING AFT

DMC005-82

**2.7.2 CARGO LOADING DOORS – MAIN DECK  
MODEL MD-11F/CF**

REV D

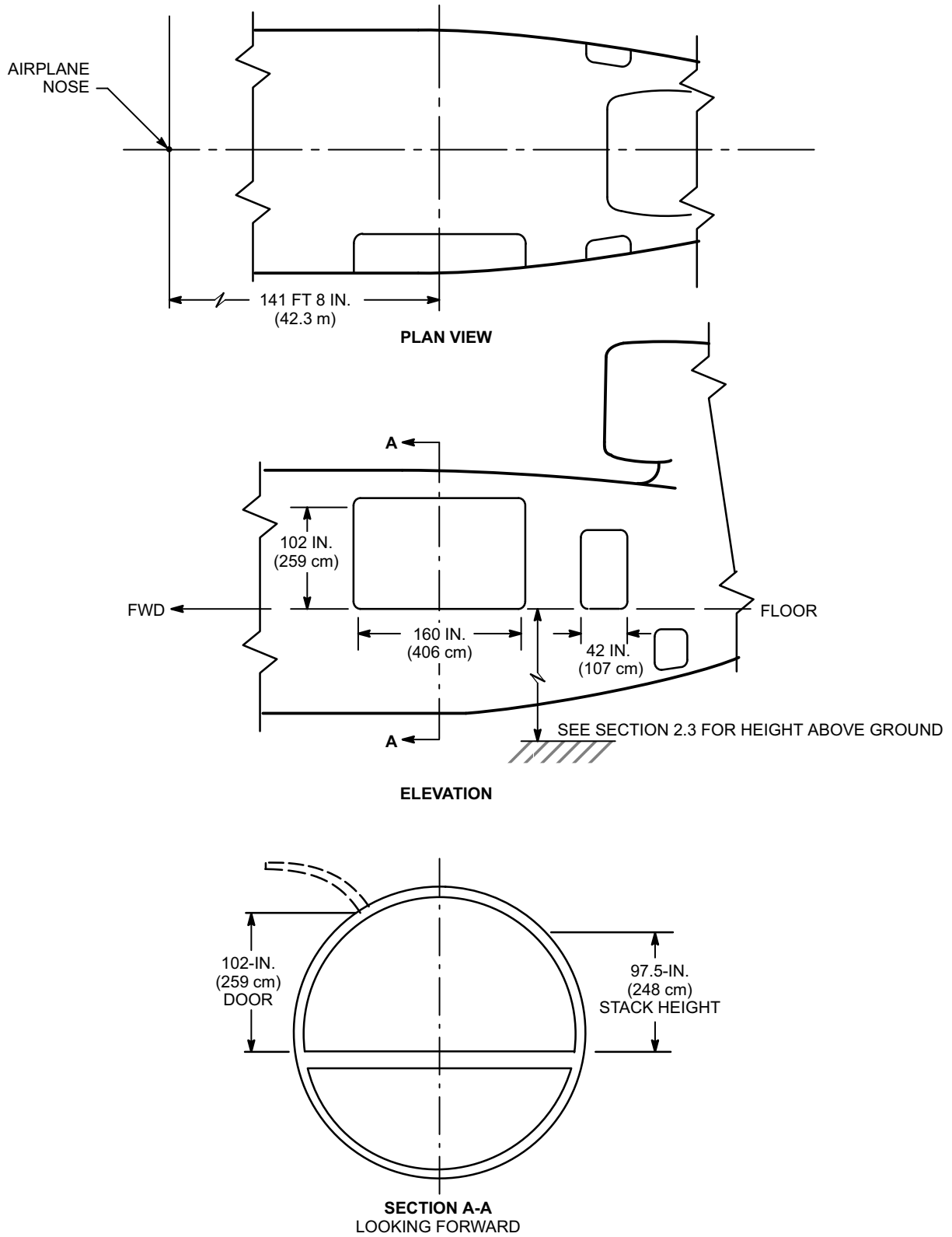

**2.7.2 CARGO LOADING DOORS – MAIN DECK  
MODEL MD-11 COMBI**

DMC005-83

REV D

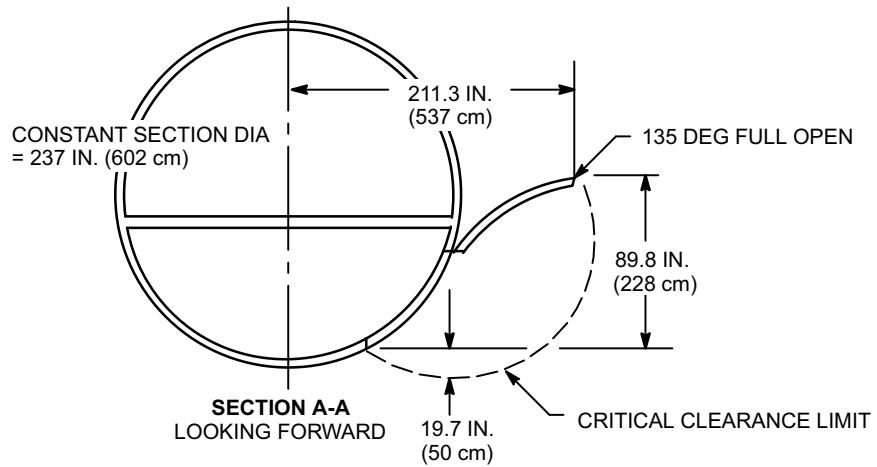
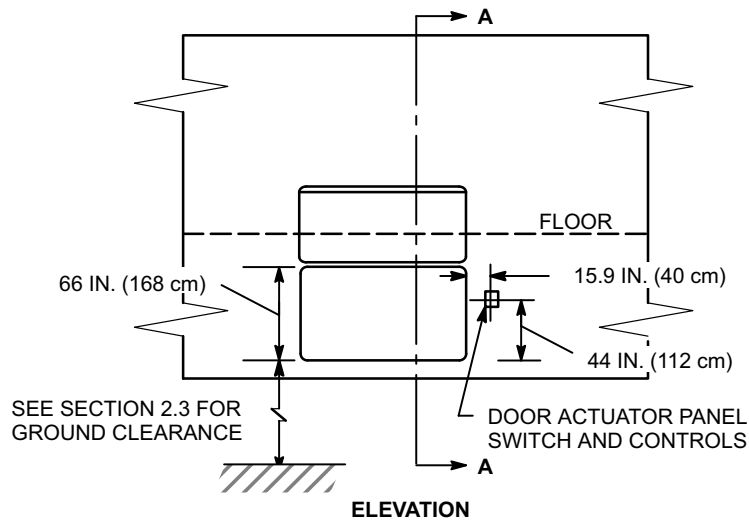
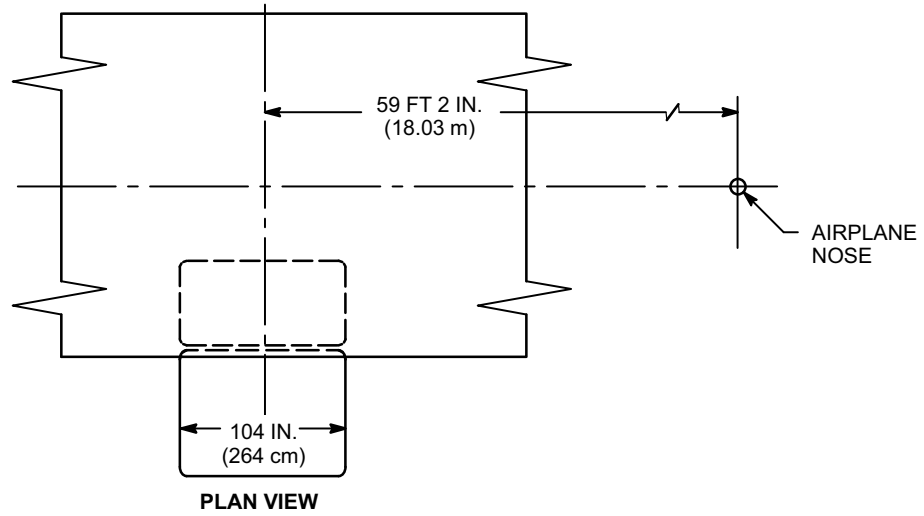

**2.7.3 CARGO LOADING DOORS, LOWER DECK  
FORWARD DOOR  
MODEL MD-11**

DMC005-94

REV D

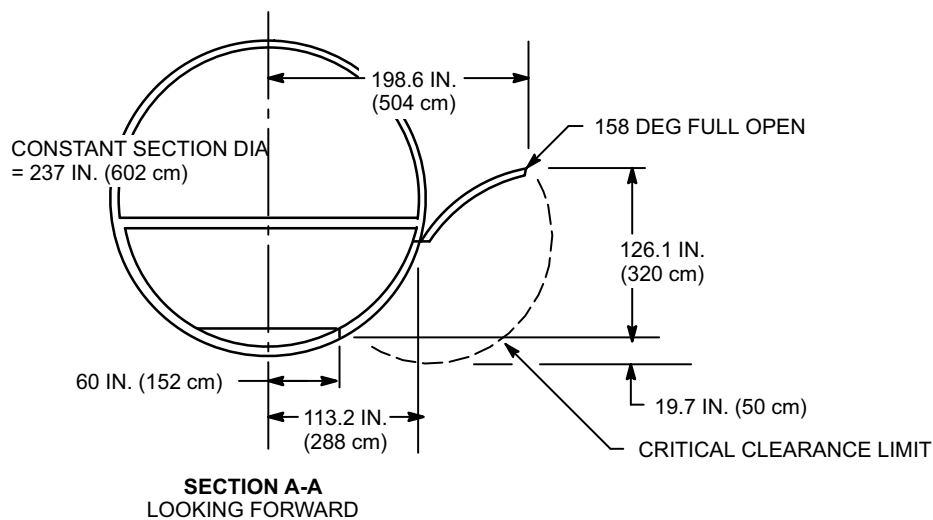
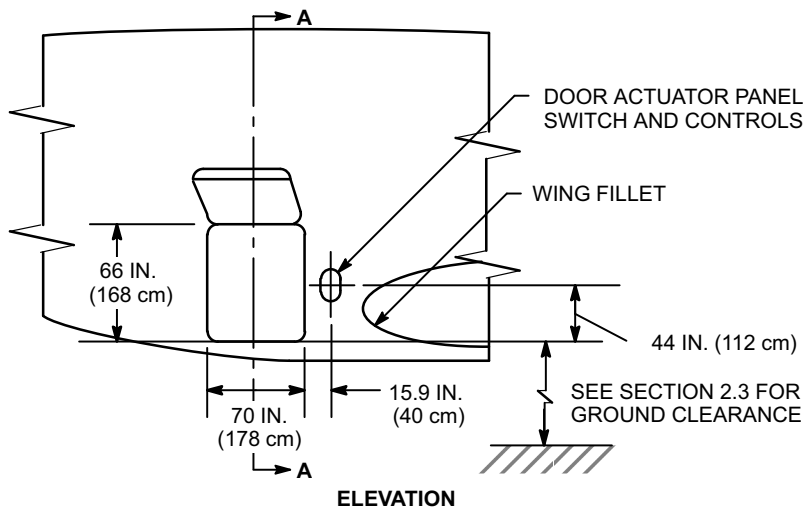
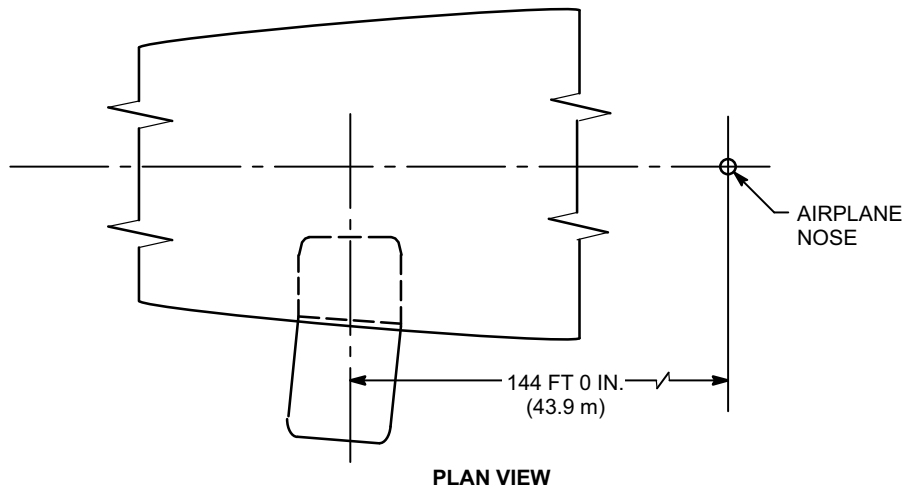

**2.7.3 CARGO LOADING DOORS, LOWER DECK  
CENTER CARGO DOOR  
MODEL MD-11**

DMC005-96

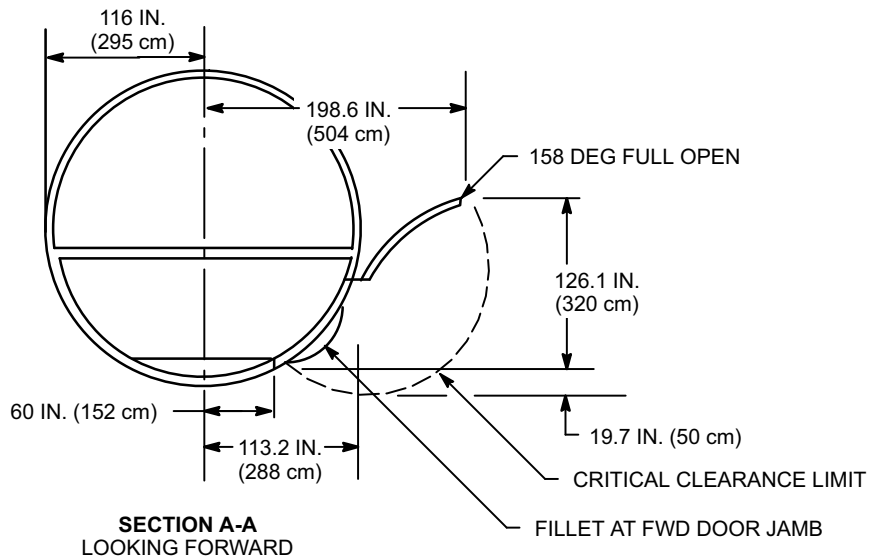
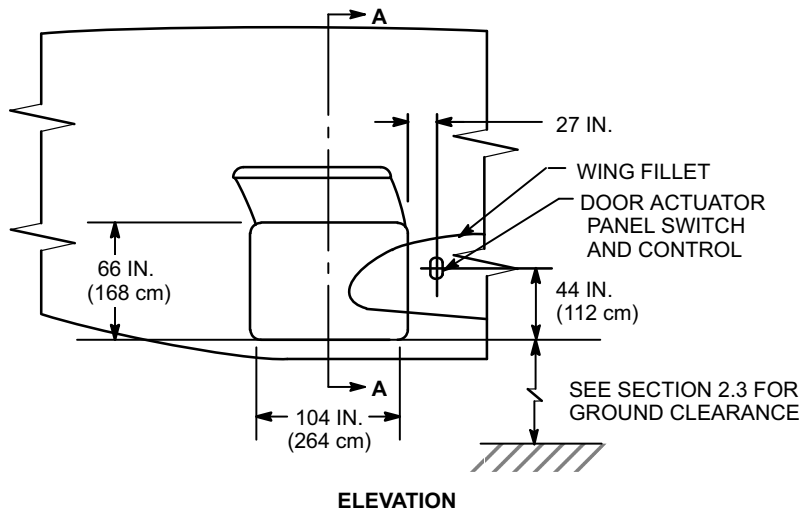
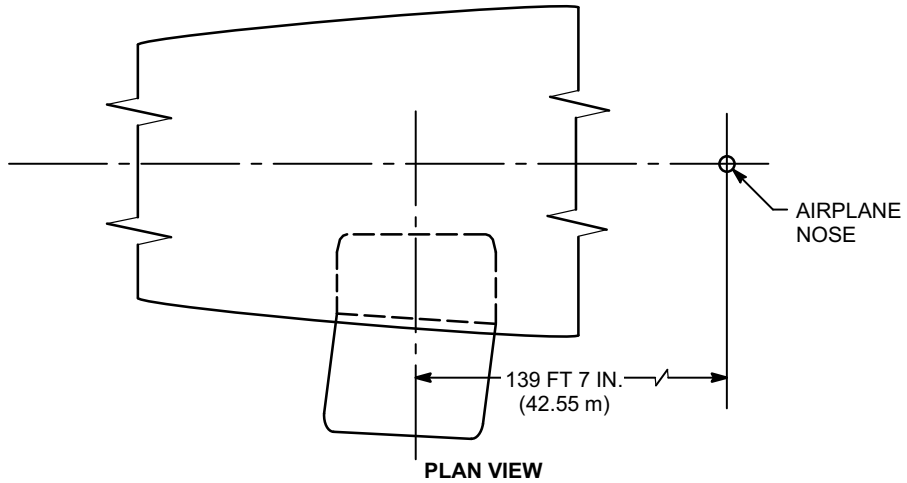

**2.7.3 CARGO LOADING DOORS, LOWER DECK  
CENTER CARGO DOOR (OPTIONAL FOR OTHER MODELS)  
MODEL MD-11 COMBI**

Chap2-Text

REV D

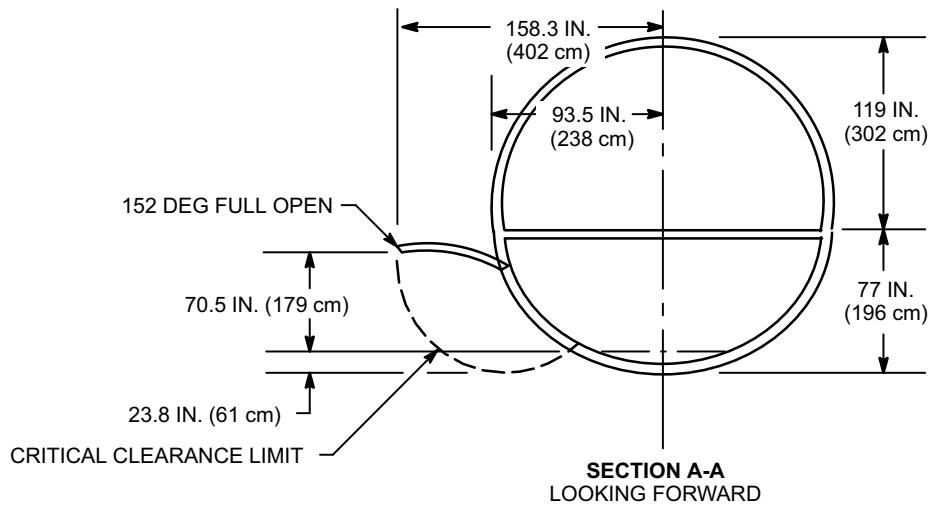
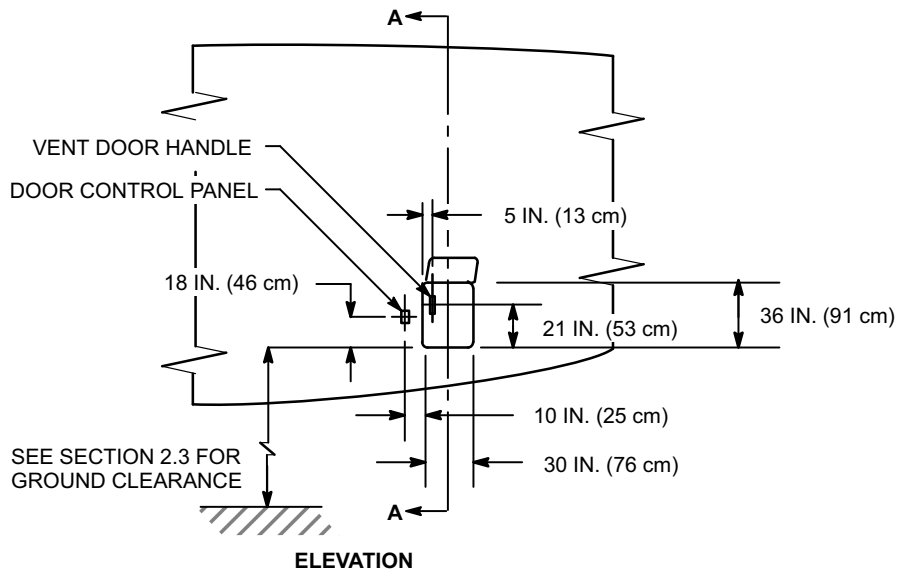
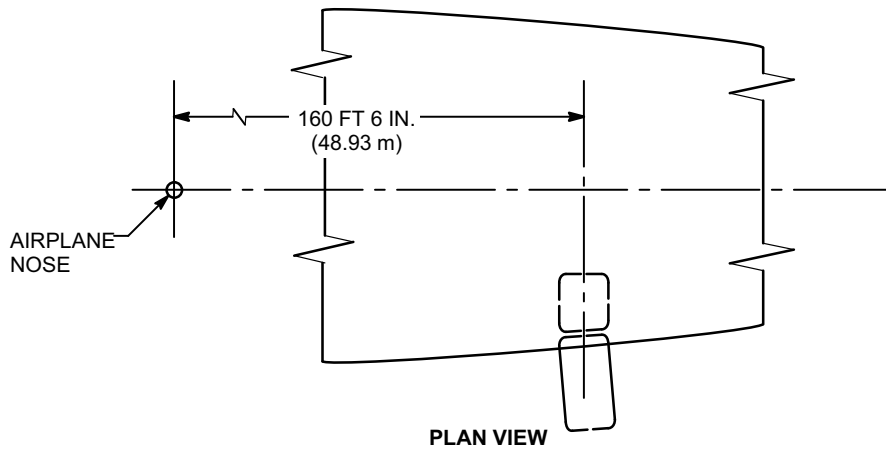

**2.7.3 CARGO LOADING DOORS, LOWER DECK  
AFT BULK CARGO DOOR  
MODEL MD-11**

DMC005-97

## **3.0 AIRPLANE PERFORMANCE**

### **3.1 General Information**

### **3.2 Payload-Range**

### **3.3 FAR Takeoff Runway Length Requirements**

### **3.4 FAR Landing Runway Length Requirements**

### 3.0 AIRPLANE PERFORMANCE

#### 3.1 General Information

Figures 3.2.1 through 3.2.8 present payload-range information for a specific Mach number cruise at the fuel reserve condition shown.

Figures 3.3.1 through 3.4.2 represent FAR takeoff and landing field length requirements for FAA certification.

Standard day temperatures for the altitudes shown are tabulated below:

ELEVATION		STANDARD DAY TEMPERATURE	
FEET	METERS	°F	°C
0	0	59	15
2,000	610	51.9	11.1
4,000	1,220	44.7	7.1
6,000	1,830	37.6	3.1
8,000	2,440	30.5	-0.8

Note: These data are provided for information only and are not to be used for flight planning purposes.

For specific performance data/analysis, contact the using airline or the Airport Compatibility Group at (562) 593-5511 or:

Douglas Aircraft Company  
Attn: Airport Compatibility Group  
3855 Lakewood Blvd.  
Long Beach, CA 90846-0001 USA



NOT TO BE USED FOR  
FLIGHT PLANNING PURPOSES

- CF6-80C2D1F ENGINES
- FAR INTERNATIONAL RESERVES 150 NM ALTERNATE PLUS MISSED APPROACH
- STEP CRUISE AT 31-35-39,000 FT AT MACH 0.82
- STANDARD DAY
- NO WIND
- OEW - 287,594 LB, 130,435 KG
- MTOW - 618,000 LB, 280,325 KG

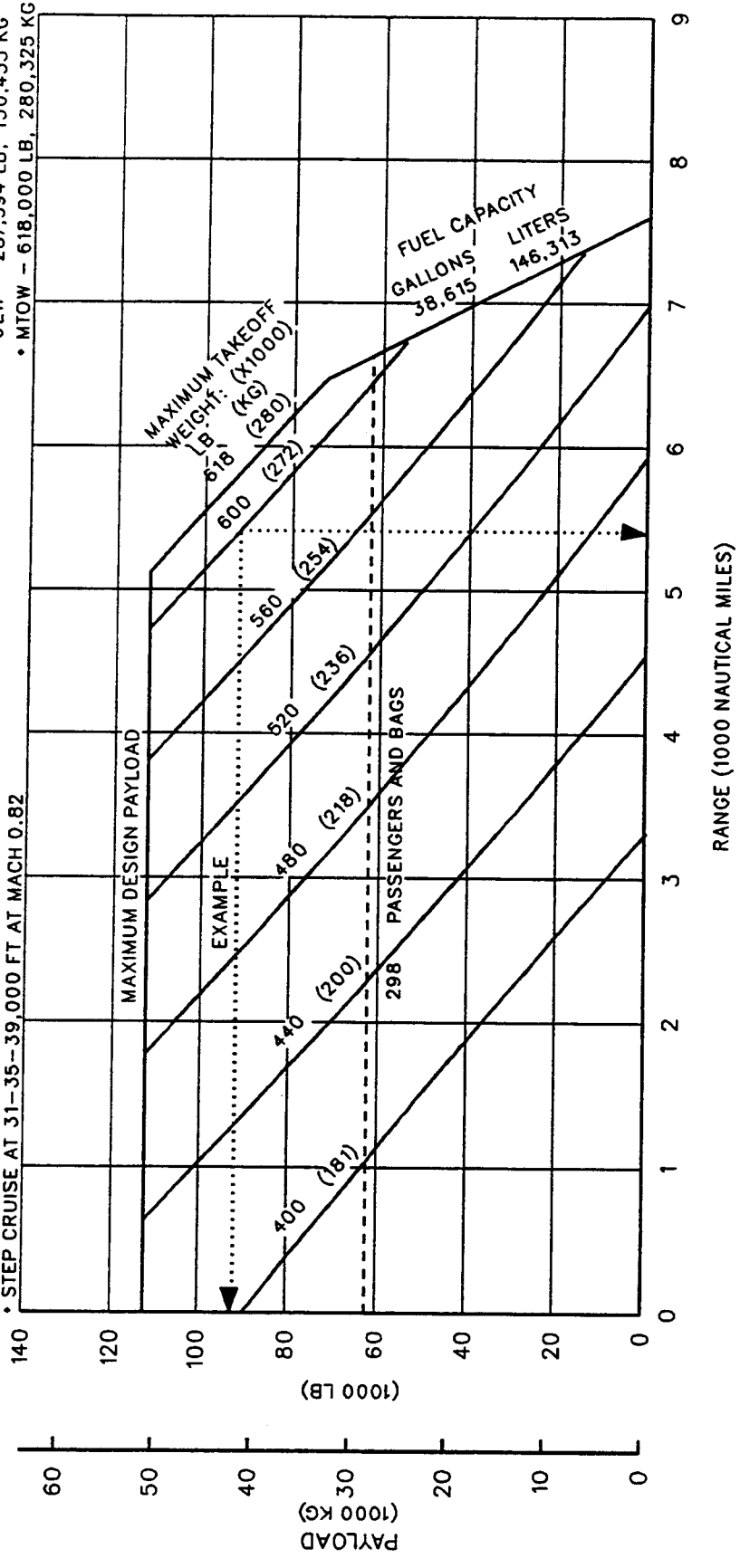

### 3.2 PAYLOAD-RANGE 3.2.1 GE ENGINE MODEL MD-11 PASSENGER

NOT TO BE USED FOR  
FLIGHT PLANNING PURPOSES

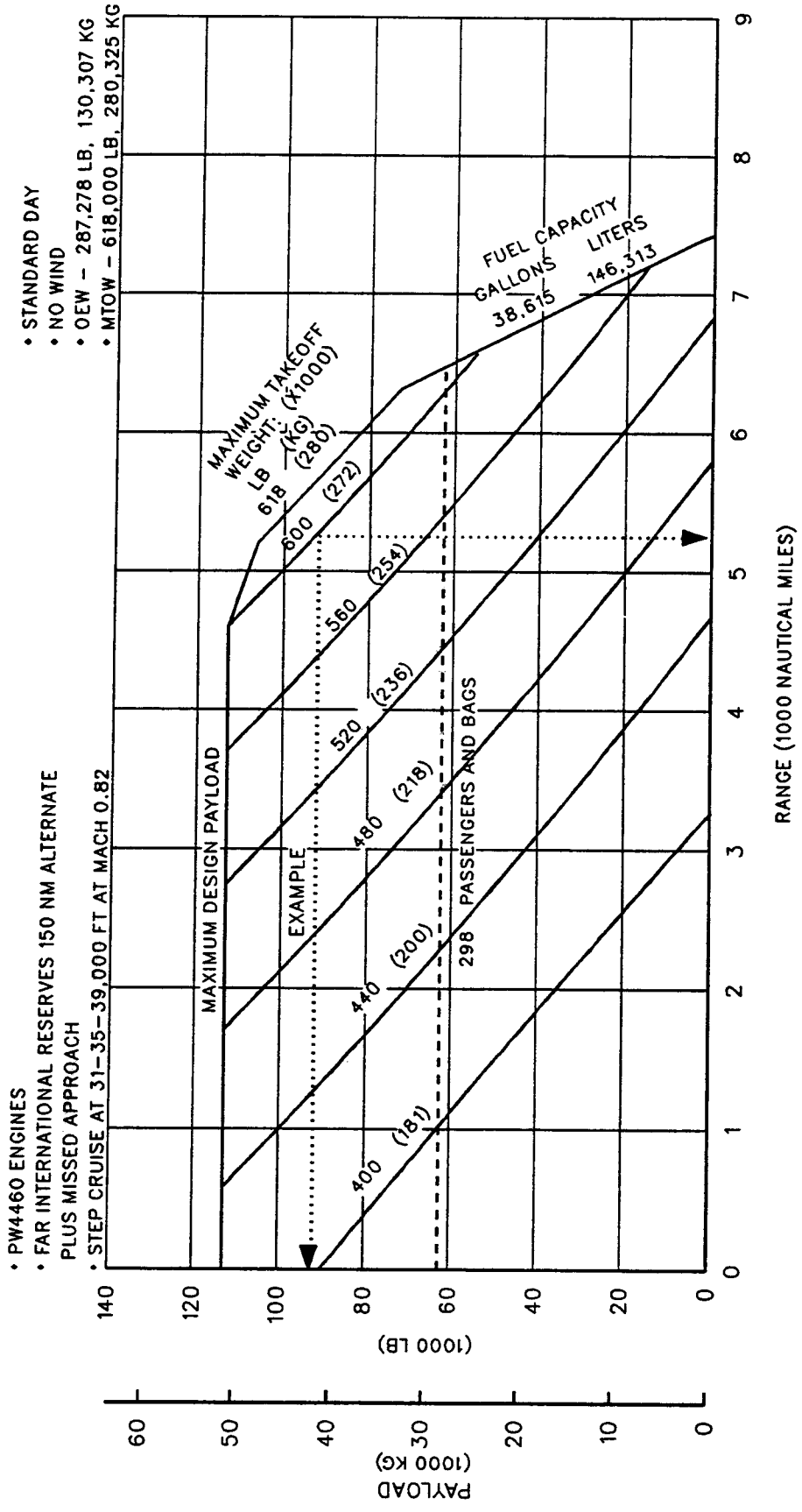

**3.2 PAYLOAD-RANGE  
3.2.2 PW ENGINE  
MODEL MD-11 PASSENGER**

NOT TO BE USED FOR  
FLIGHT PLANNING PURPOSES

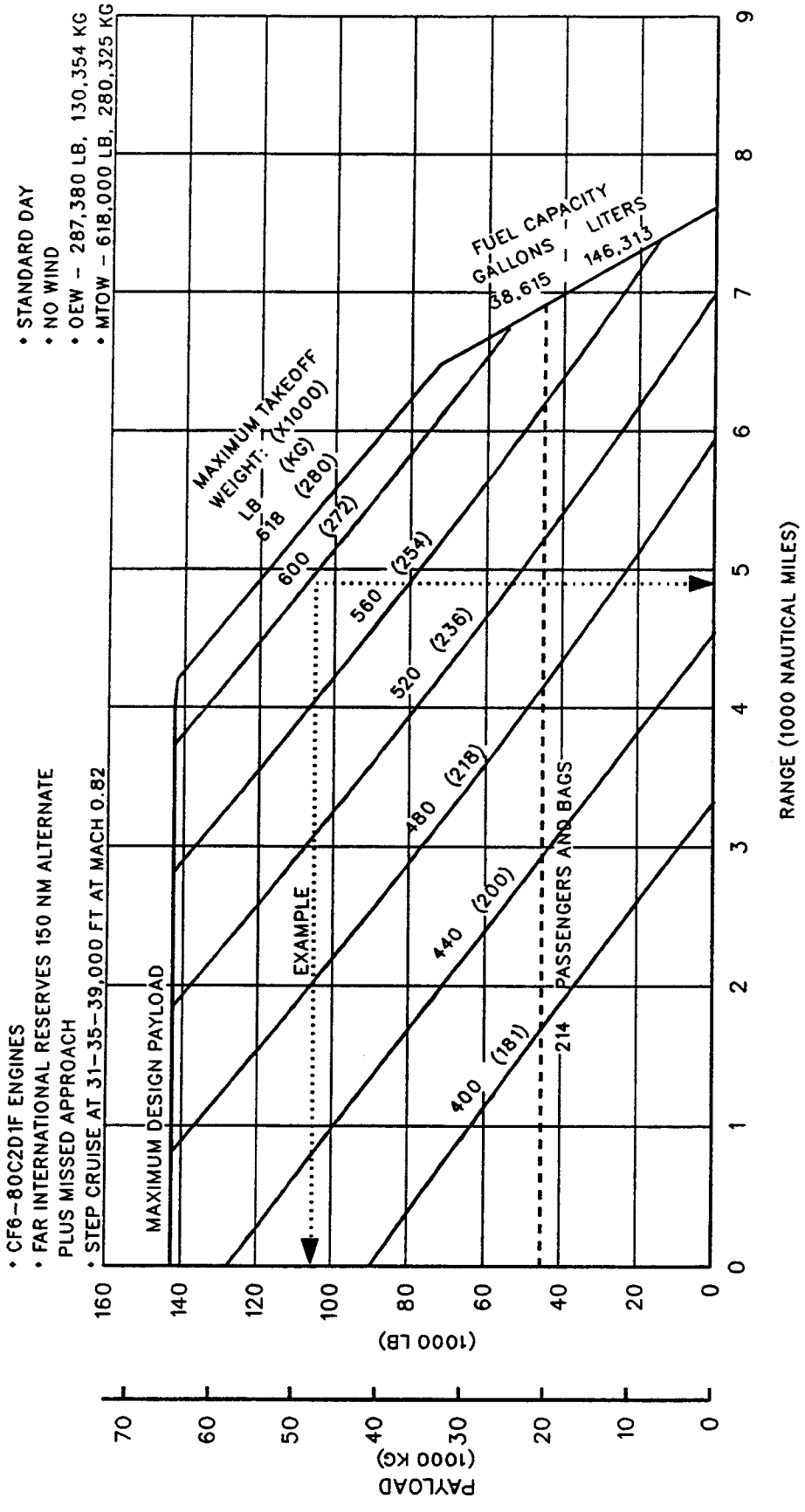

**3.2 PAYLOAD-RANGE**  
**3.2.3 GE ENGINE**  
**MODEL MD-11 COMBI**

NOT TO BE USED FOR  
FLIGHT PLANNING PURPOSES

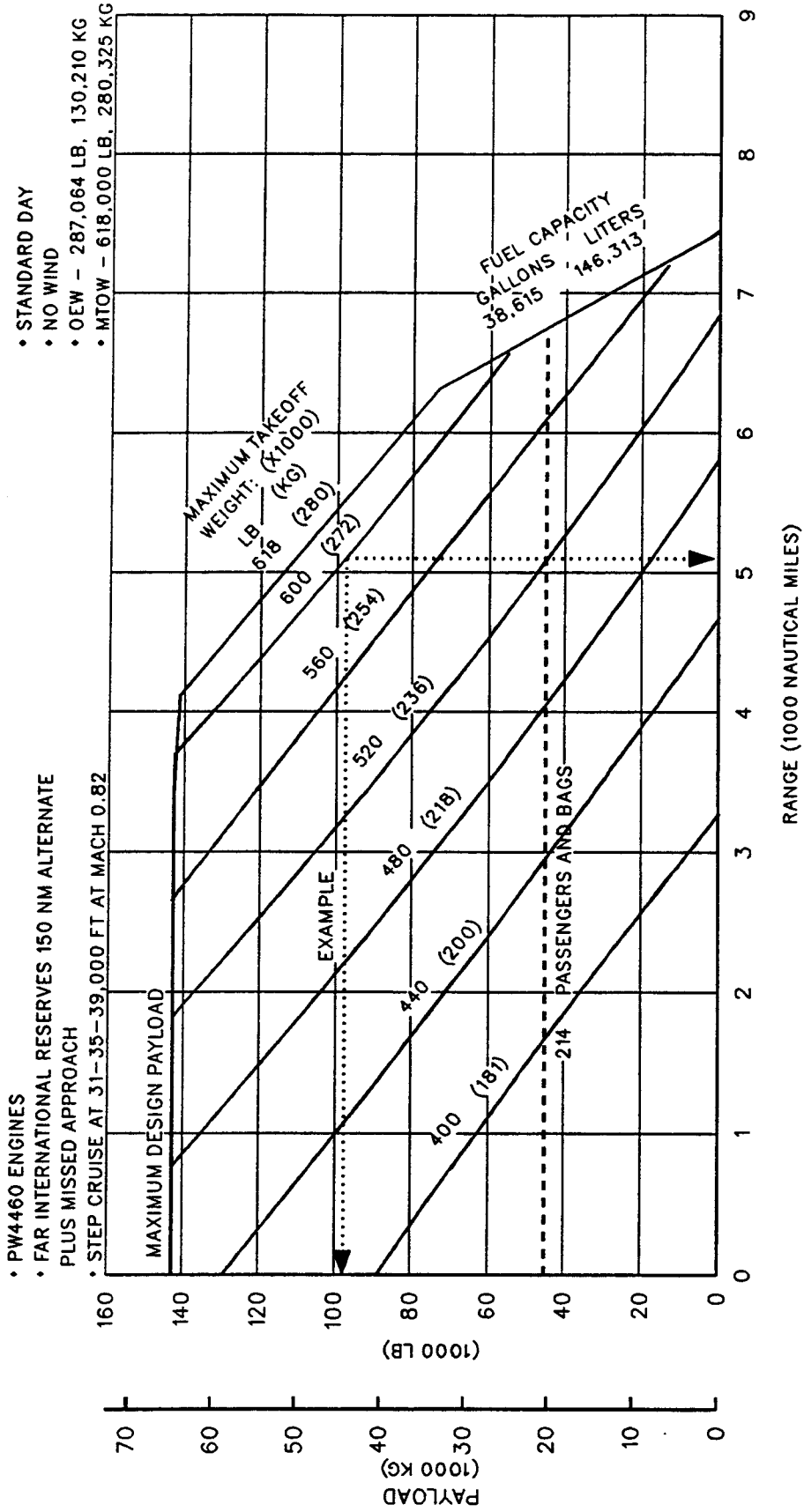

3.2 PAYLOAD-RANGE  
3.2.4 PW ENGINE  
MODEL MD-11 COMBI

NOT TO BE USED FOR  
FLIGHT PLANNING PURPOSES

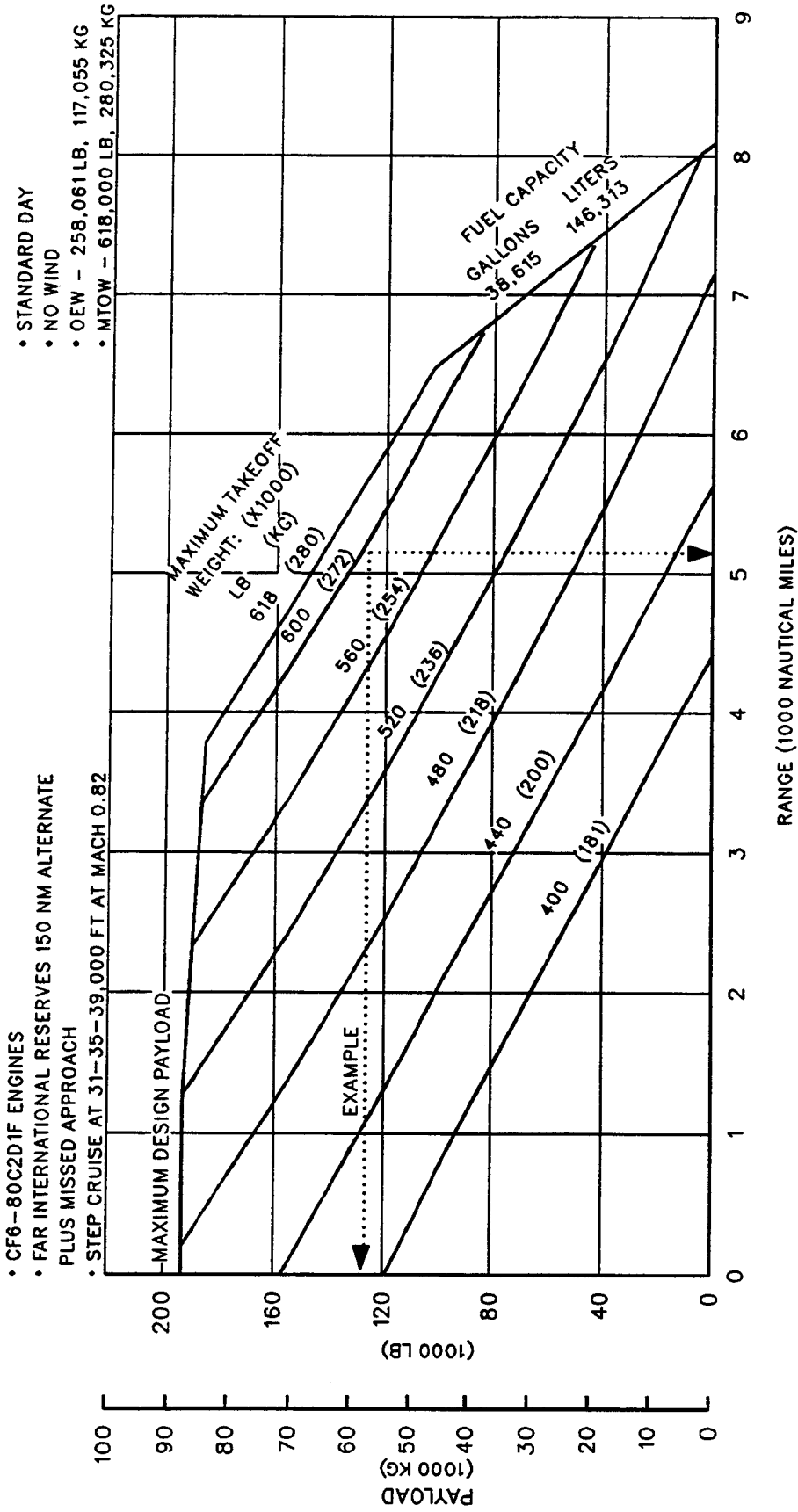

3.2 PAYLOAD-RANGE  
 3.2.5 GE ENGINE  
 MODEL MD-11 CONVERTIBLE FREIGHTER

NOT TO BE USED FOR  
FLIGHT PLANNING PURPOSES

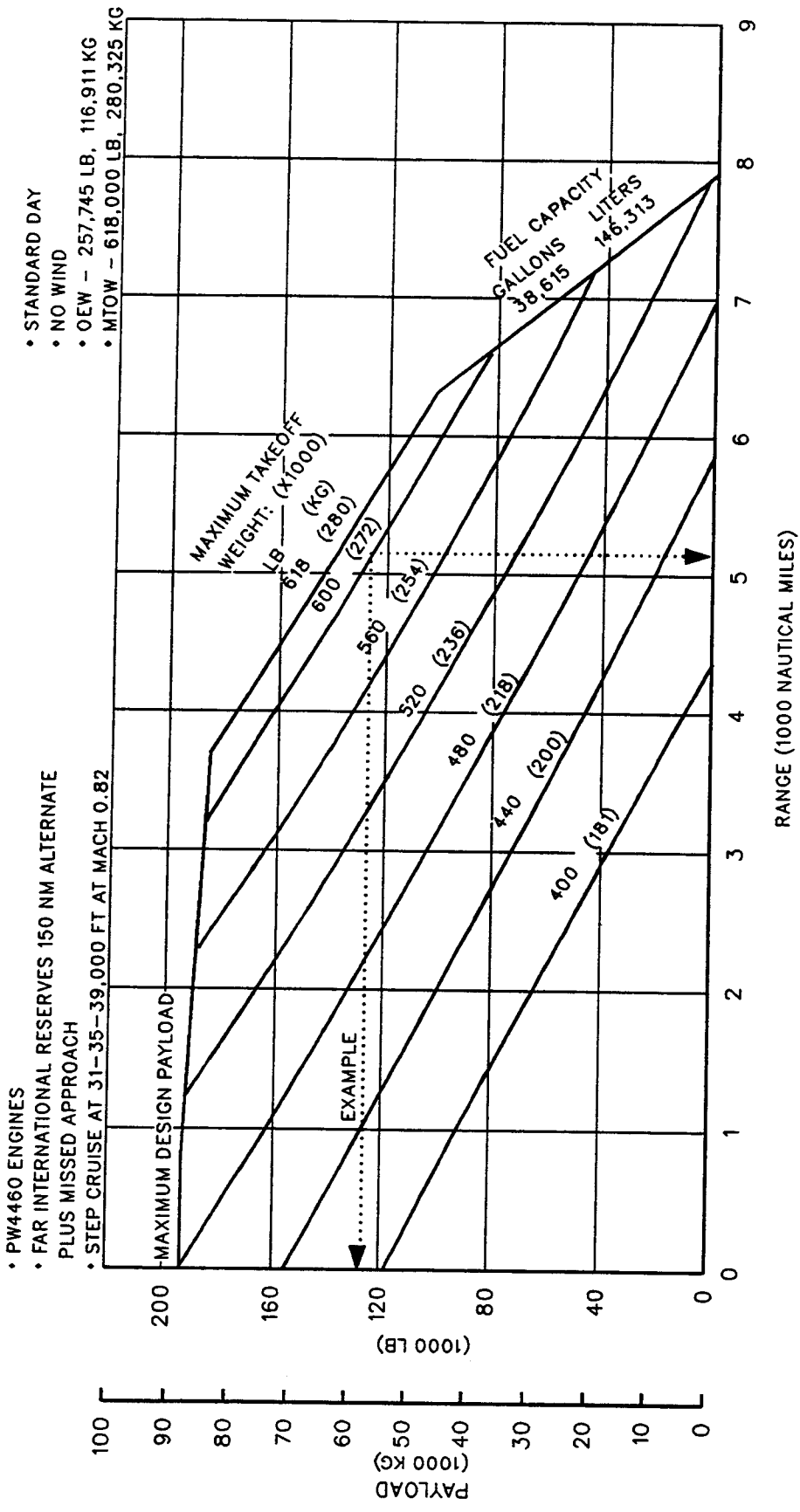

3.2 PAYLOAD-RANGE  
 3.2.6 PW ENGINE  
 MODEL MD-11 CONVERTIBLE FREIGHTER

NOT TO BE USED FOR  
FLIGHT PLANNING PURPOSES

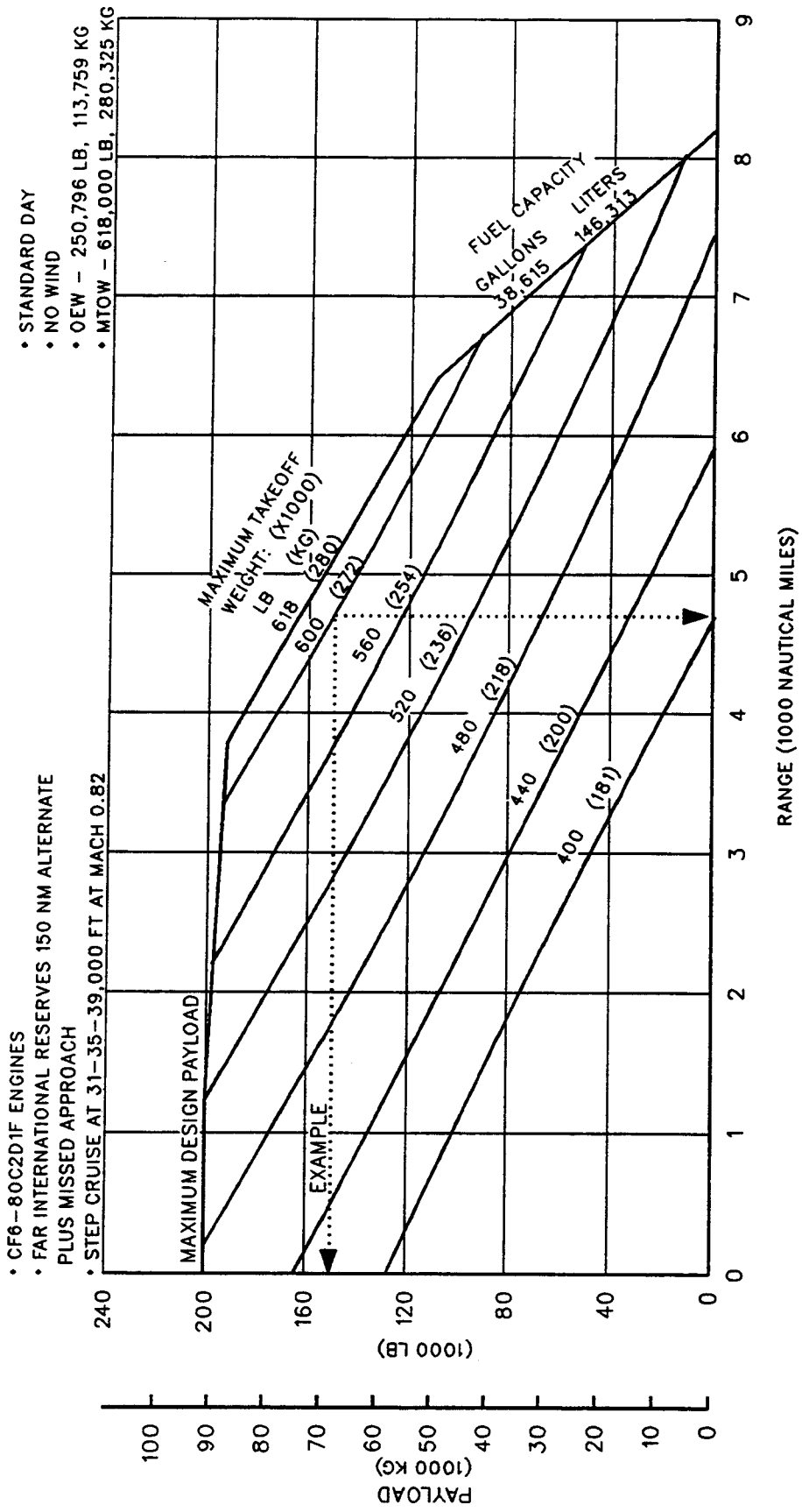

3.2 PAYLOAD-RANGE  
 3.2.7 GE ENGINE  
 MODEL MD-11 FREIGHTER

NOT TO BE USED FOR  
FLIGHT PLANNING PURPOSES

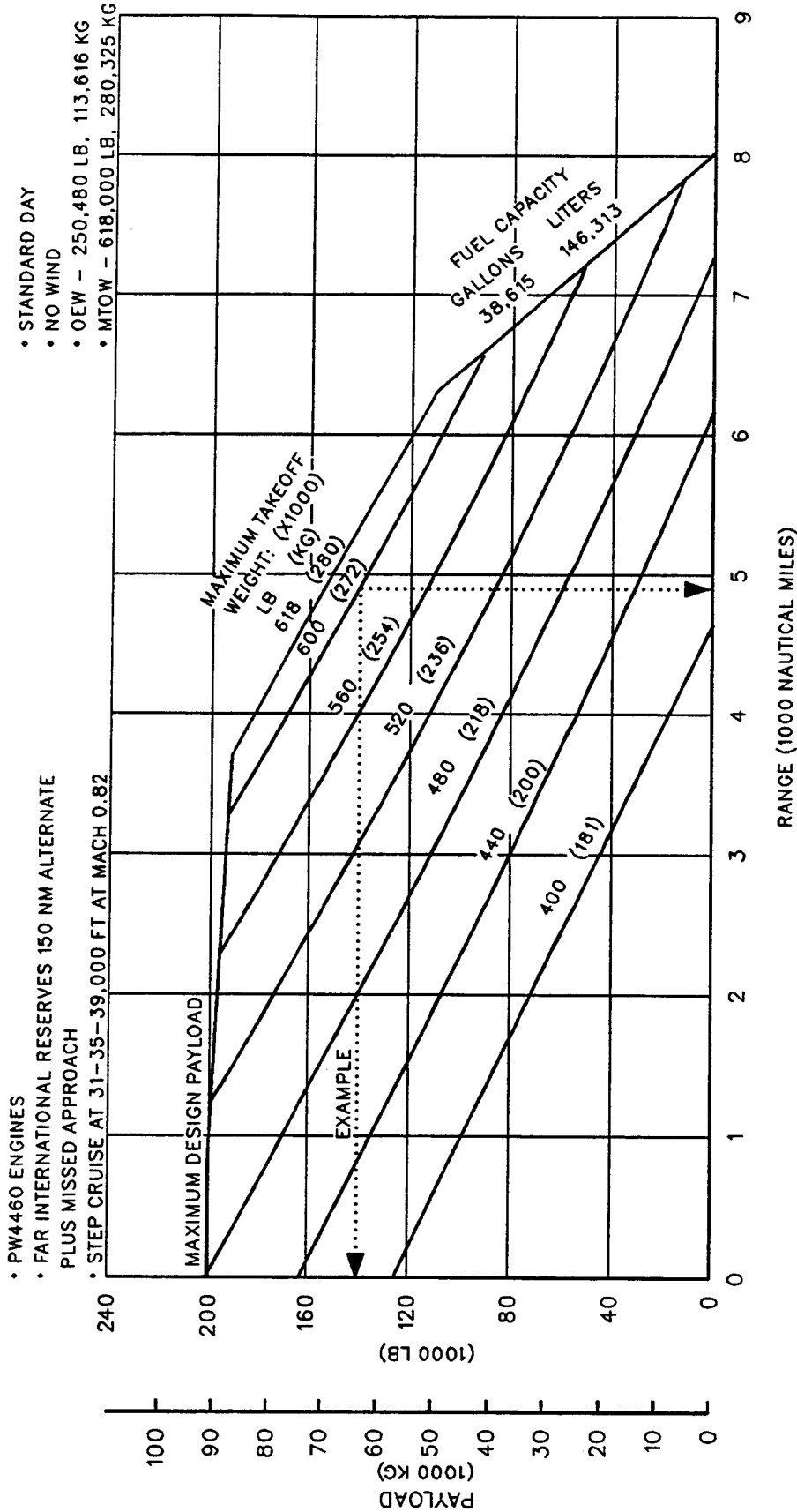

- PW4460 ENGINES
- FAR INTERNATIONAL RESERVES 150 NM ALTERNATE PLUS MISSED APPROACH
- STEP CRUISE AT 31-35-39,000 FT AT MACH 0.82
- STANDARD DAY
- NO WIND
- OEW - 250,480 LB, 113,616 KG
- MTOW - 618,000 LB, 280,325 KG

### 3.2 PAYLOAD-RANGE 3.2.8 PW ENGINE MODEL MD-11 FREIGHTER



NOT TO BE USED FOR  
FLIGHT PLANNING PURPOSES

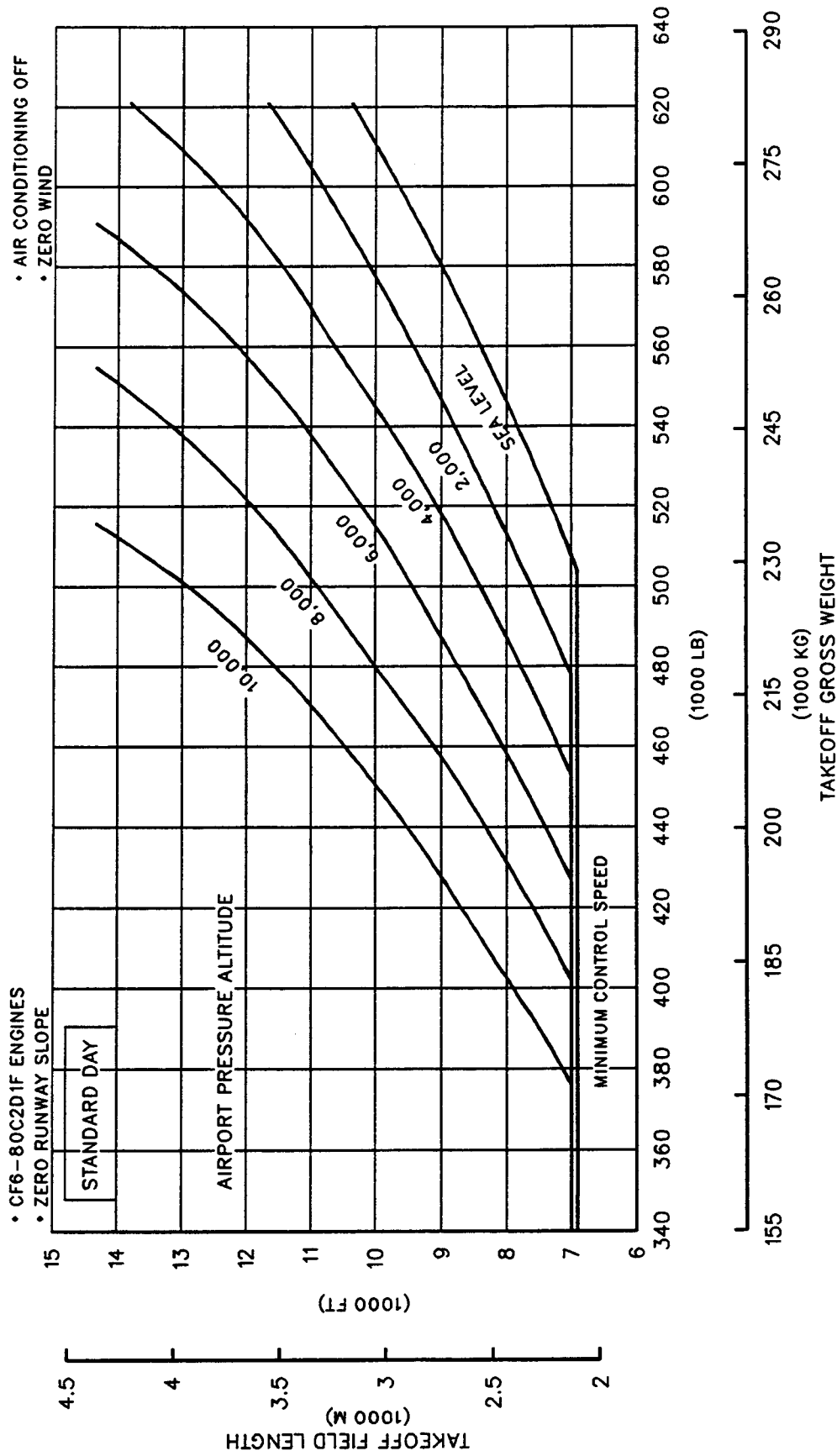

### 3.3 FAR TAKEOFF FIELD LENGTH REQUIREMENTS 3.3.1 STANDARD DAY MODEL MD-11 GE ENGINE

NOT TO BE USED FOR  
FLIGHT PLANNING PURPOSES

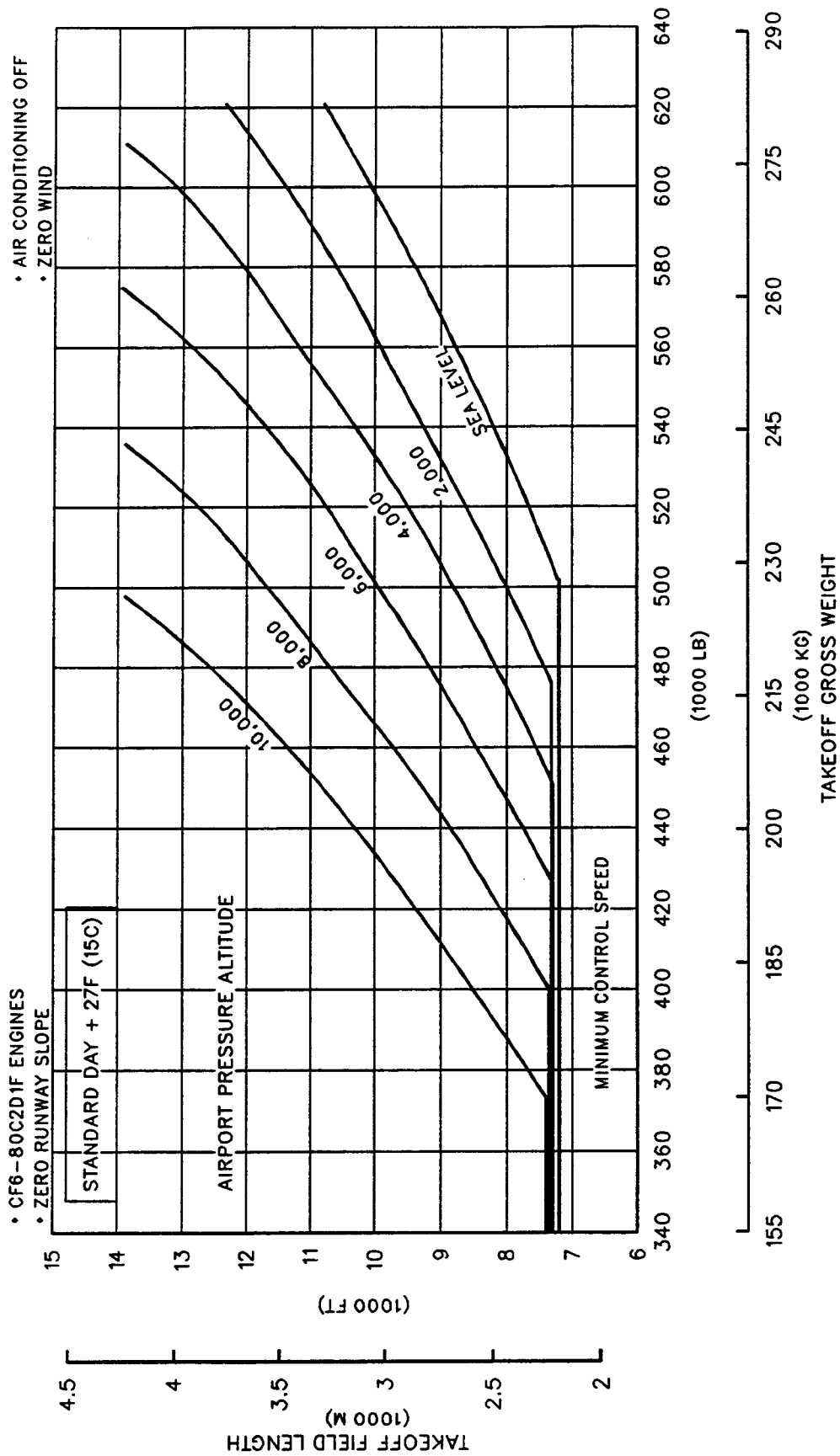

**3.3 FAR TAKEOFF FIELD LENGTH REQUIREMENTS**  
**3.3.2 STANDARD DAY + 27F (15C)**  
**MODEL MD-11 GE ENGINE**

NOT TO BE USED FOR  
FLIGHT PLANNING PURPOSES

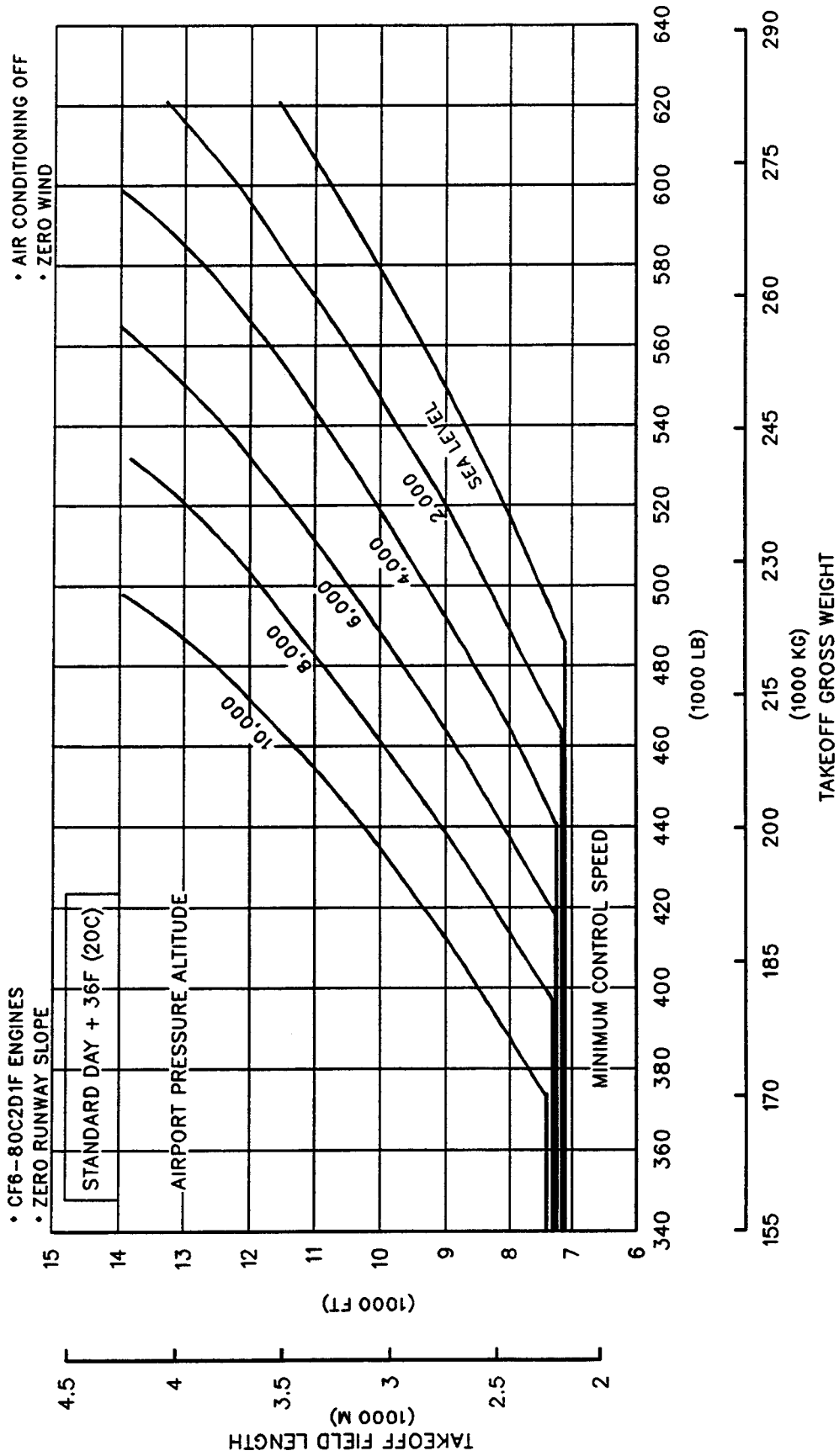

3.3 FAR TAKEOFF FIELD LENGTH REQUIREMENTS  
3.3.3 STANDARD DAY + 36F (20C)  
MODEL MD-11 GE ENGINE

NOT TO BE USED FOR  
FLIGHT PLANNING PURPOSES

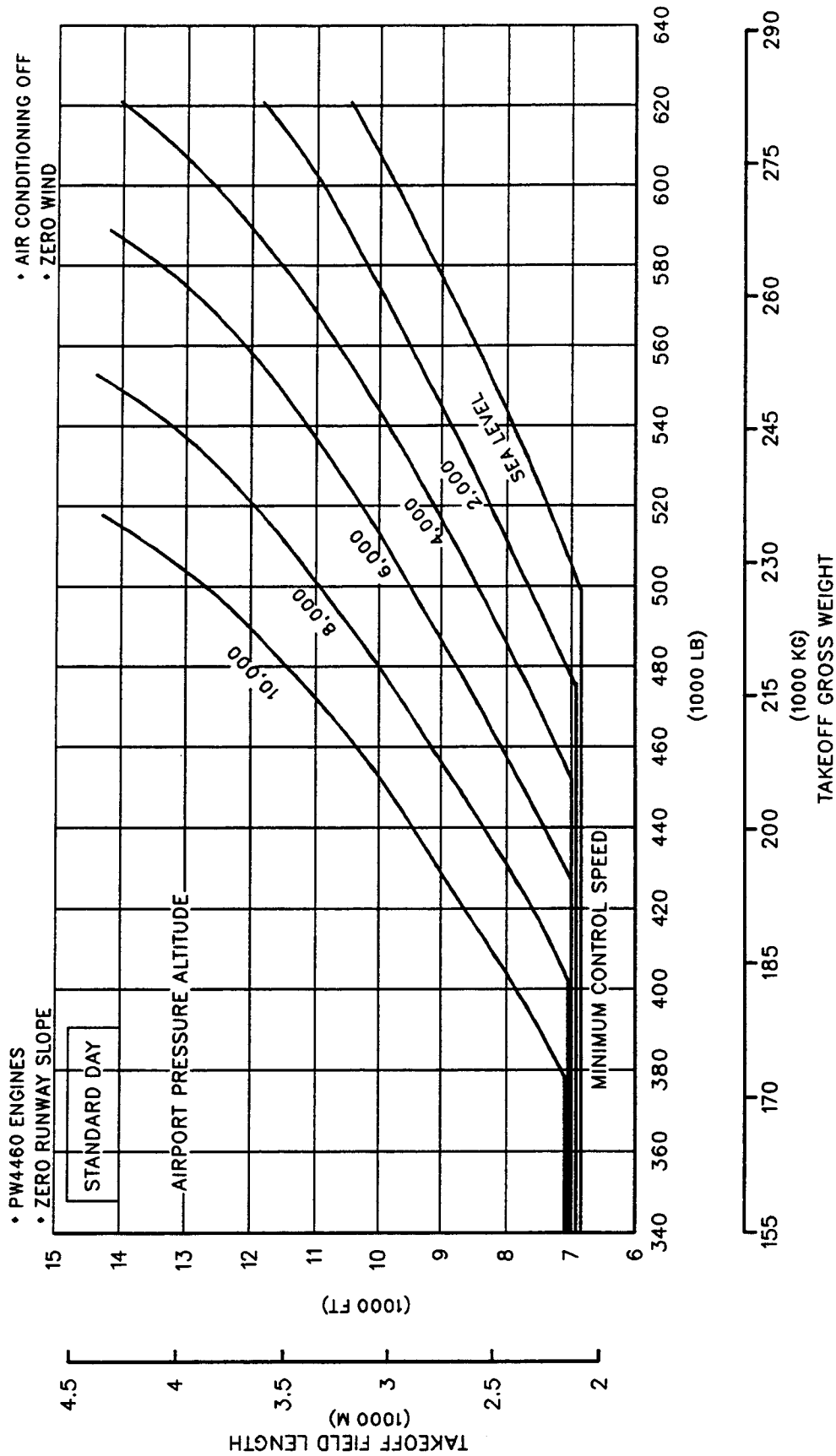

**3.3 FAR TAKEOFF FIELD LENGTH REQUIREMENTS**  
**3.3.4 STANDARD DAY**  
**MODEL MD-11 PW ENGINE**

NOT TO BE USED FOR  
FLIGHT PLANNING PURPOSES

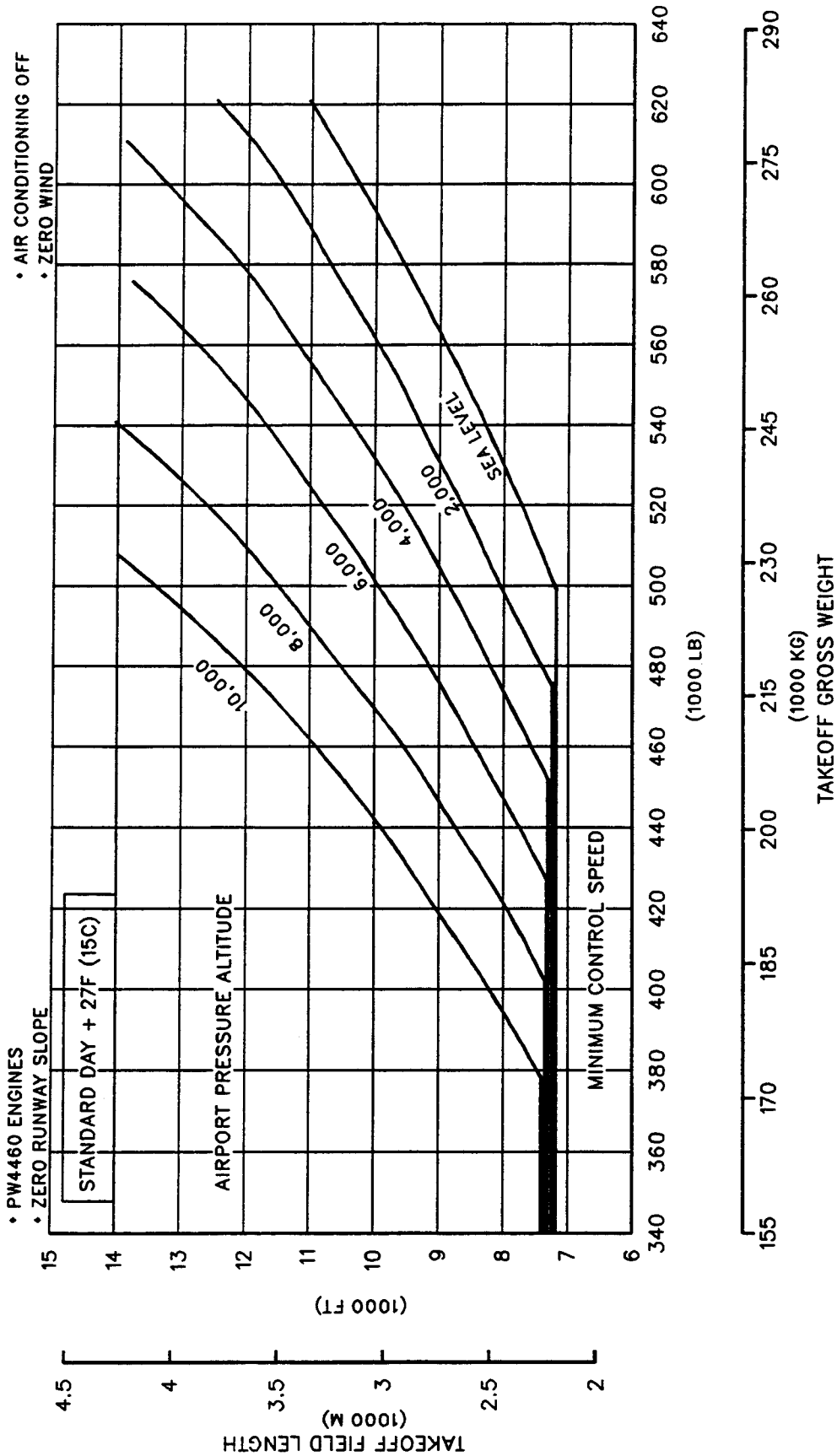

**3.3 FAR TAKEOFF FIELD LENGTH REQUIREMENTS**  
**3.3.5 STANDARD DAY + 27F (15C)**  
**MODEL MD-11 PW ENGINE**

NOT TO BE USED FOR  
FLIGHT PLANNING PURPOSES

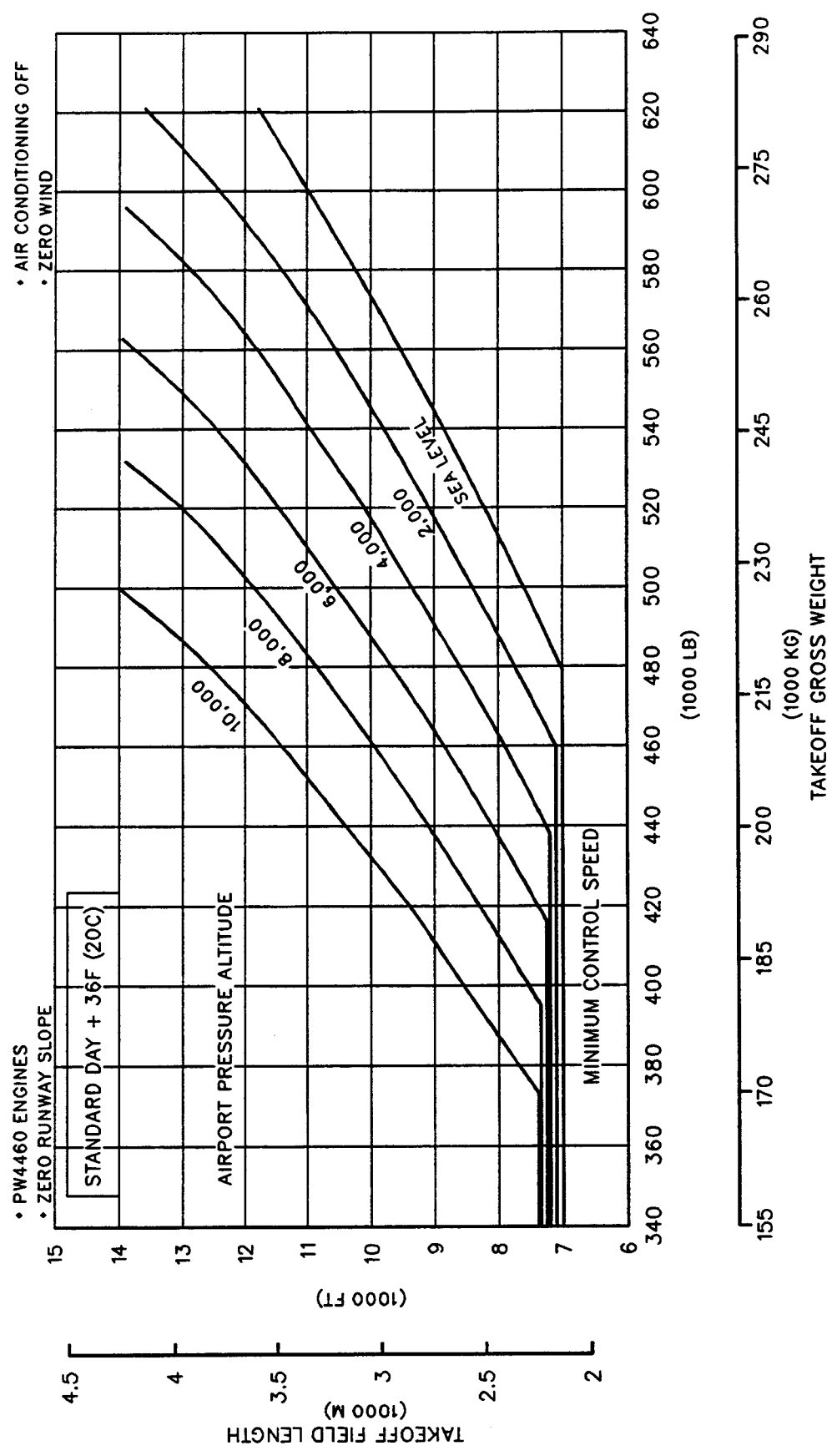

**3.3 FAR TAKEOFF FIELD LENGTH REQUIREMENTS**  
**3.3.6 STANDARD DAY + 36F (20C)**  
**MODEL MD-11 PW ENGINE**

NOT TO BE USED FOR  
FLIGHT PLANNING PURPOSES

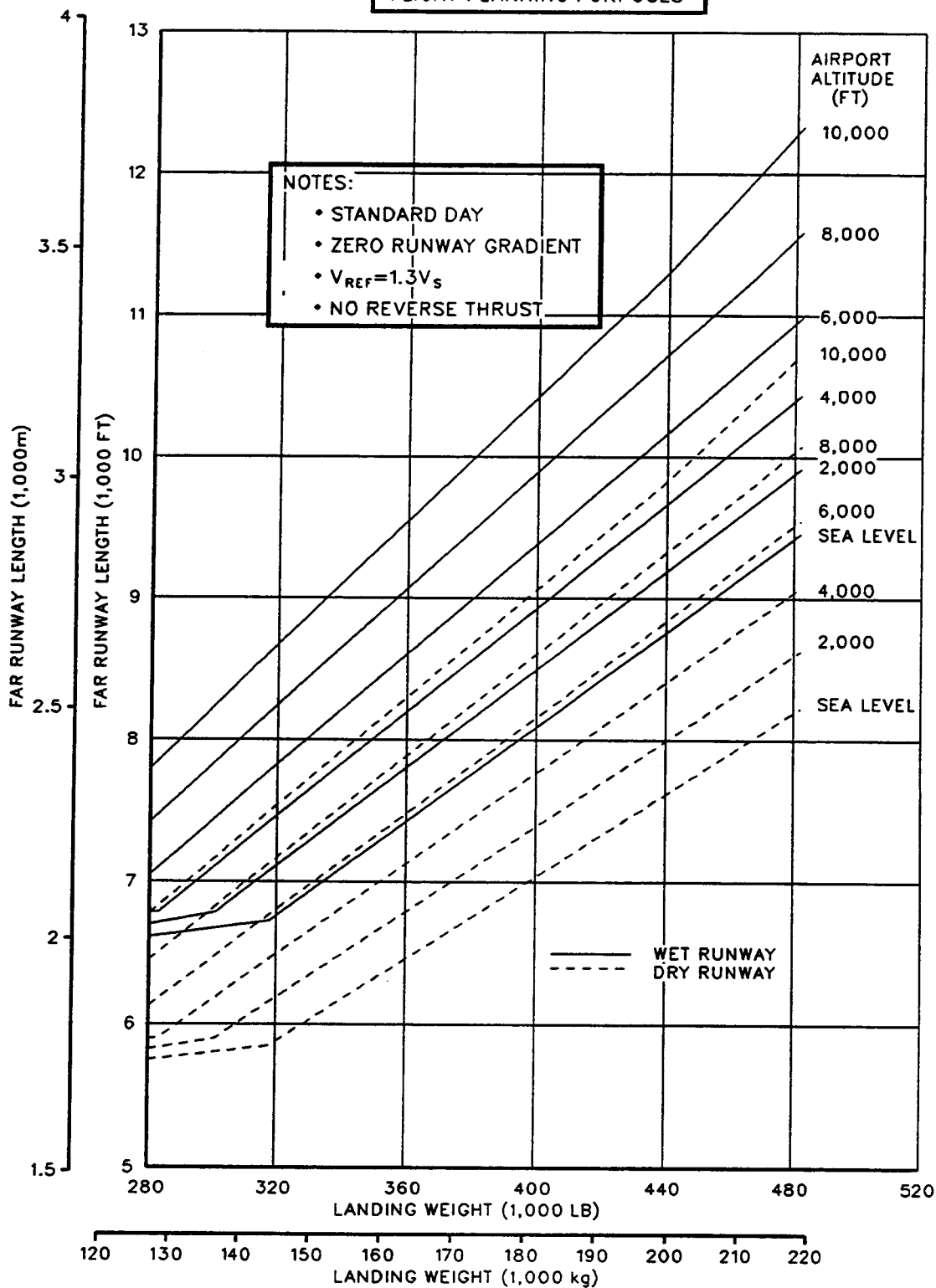

**3.4 FAR LANDING RUNWAY LENGTH REQUIREMENTS**

**3.4.1 FLAPS 35 DEGREES**

**MODEL MD-11**

REV D

NOT TO BE USED FOR  
FLIGHT PLANNING PURPOSES

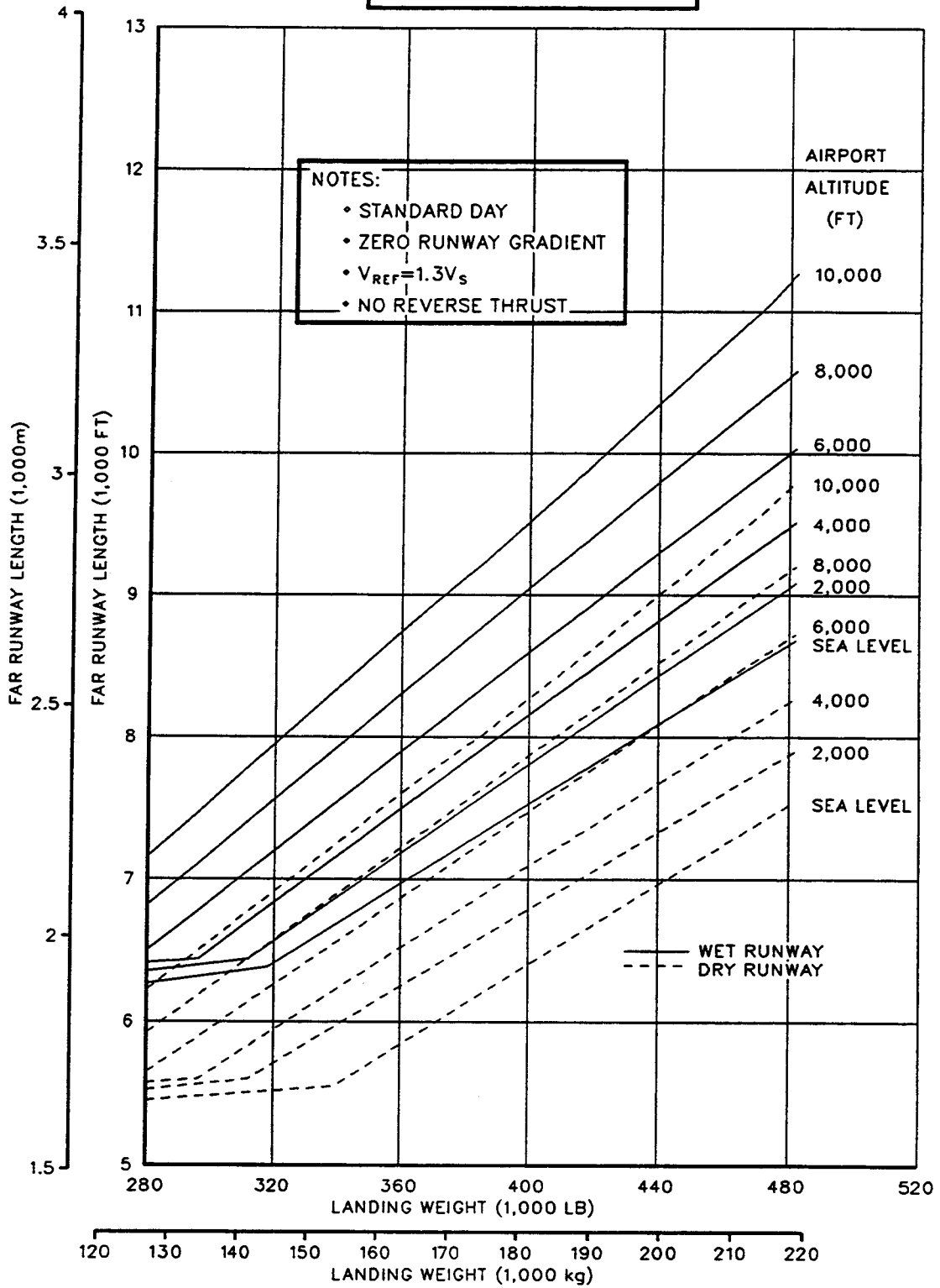

**3.4 FAR LANDING RUNWAY LENGTH REQUIREMENTS**  
**3.4.2 FLAPS 50 DEGREES**  
**MODEL MD-11**

REV D



## **4.0 GROUND MANEUVERING**

**4.1 General Information**

**4.2 Turning Radii, No Slip Angle**

**4.3 Minimum Turning Radii**

**4.4 Visibility from Cockpit**

**4.5 Runway and Taxiway Turn Paths**

**4.6 Runway Holding Bay (Apron)**

## **4.0 GROUND MANEUVERING**

### **4.1 General Information**

This section provides airplane turning capability and maneuvering characteristics.

For ease of presentation, these data have been determined from the theoretical limits imposed by the geometry of the aircraft, and where noted, provide for a normal allowance for tire slippage. As such, they reflect the turning capability of the aircraft in favorable operating circumstances. The data should only be used as guidelines for determining such parameters and to obtain the maneuvering characteristics of this aircraft type.

In the ground operating mode, varying airline practices may demand that more conservative turning procedures be adopted. Airline operating techniques will vary in level of performance over a wide range of circumstances throughout the world. Variations from standard aircraft operating patterns may be necessary to satisfy physical constraints within the maneuvering area, such as adverse grades, limited space, or high risk of jet blast damage. For these reasons, ground maneuvering requirements should be coordinated with the using airlines prior to layout planning.

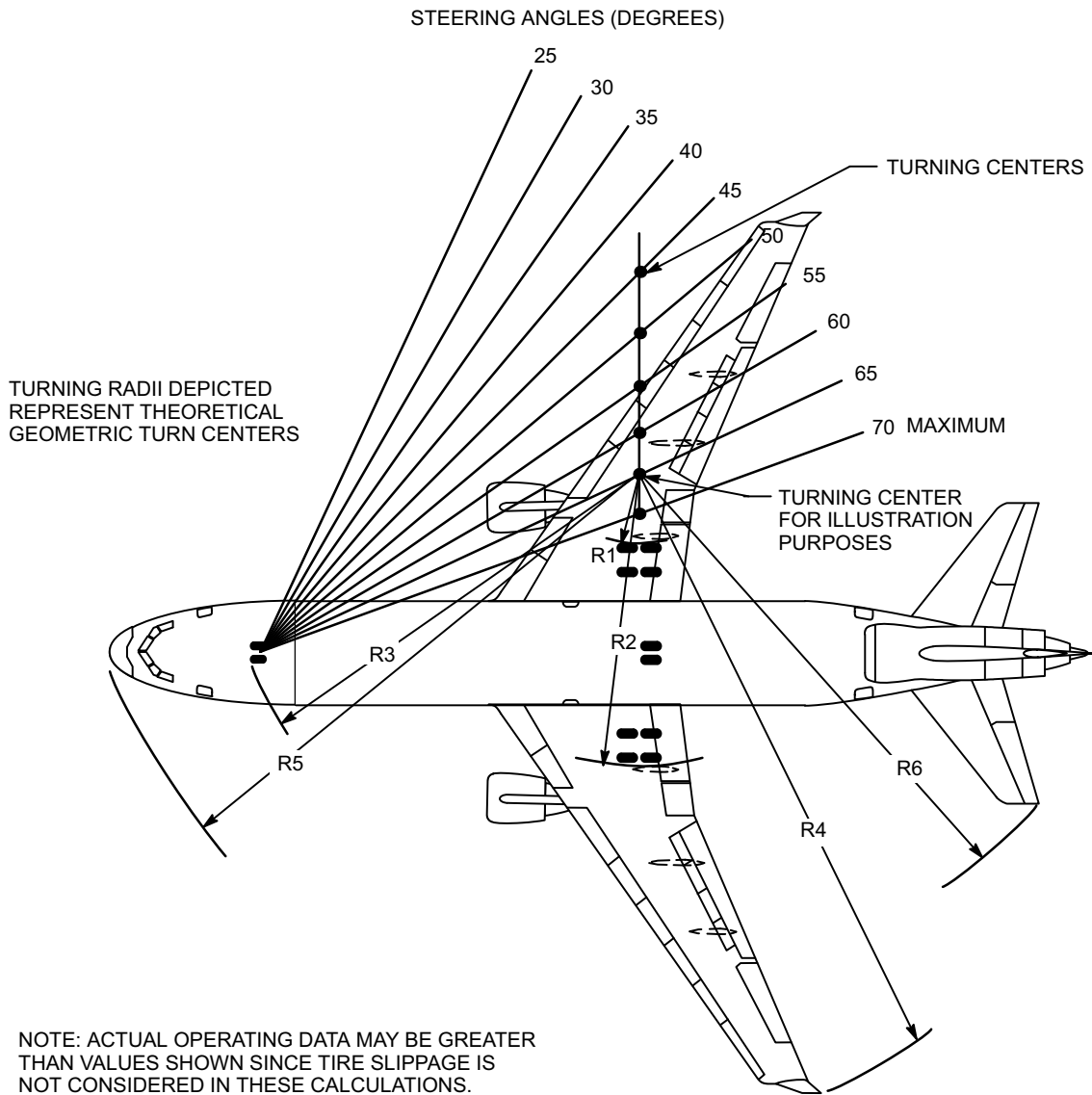

STEERING ANGLE (DEG)	R-1		R-2		R-3		R-4		R-5		R-6	
	FT	m	FT	m	FT	m	FT	m	FT	m	FT	m
25	153.7	46.8	194.9	59.4	194.0	59.1	262.6	80.0	205.7	62.7	220.2	67.1
30	120.2	36.6	161.4	49.2	164.3	50.1	229.5	69.9	178.2	54.3	189.5	57.8
35	95.5	29.1	136.7	41.7	143.5	43.7	205.2	62.5	159.4	48.6	167.7	51.2
40	76.3	23.2	117.5	35.8	128.2	39.1	186.4	56.8	145.9	44.5	151.3	46.1
45	60.7	18.5	101.9	31.1	116.6	35.6	171.2	52.2	136.1	41.5	138.5	42.2
50	47.6	14.5	88.8	27.1	107.8	32.9	158.5	48.3	128.7	39.2	128.3	39.1
55	36.3	11.1	77.5	23.6	100.9	30.8	147.6	45.0	123.1	37.5	119.9	36.6
60	26.3	8.0	67.6	20.6	95.6	29.1	138.0	42.0	118.8	36.2	112.9	34.4
65	17.3	5.3	58.5	17.8	91.4	27.9	129.4	39.4	115.6	35.2	107.0	32.6
70 MAXIMUM	9.0	2.7	50.2	15.3	88.2	26.9	121.5	37.0	113.8	34.5	102.0	31.1

DMC005-40

### 4.2 TURNING RADII, NO SLIP ANGLE MODEL MD-11

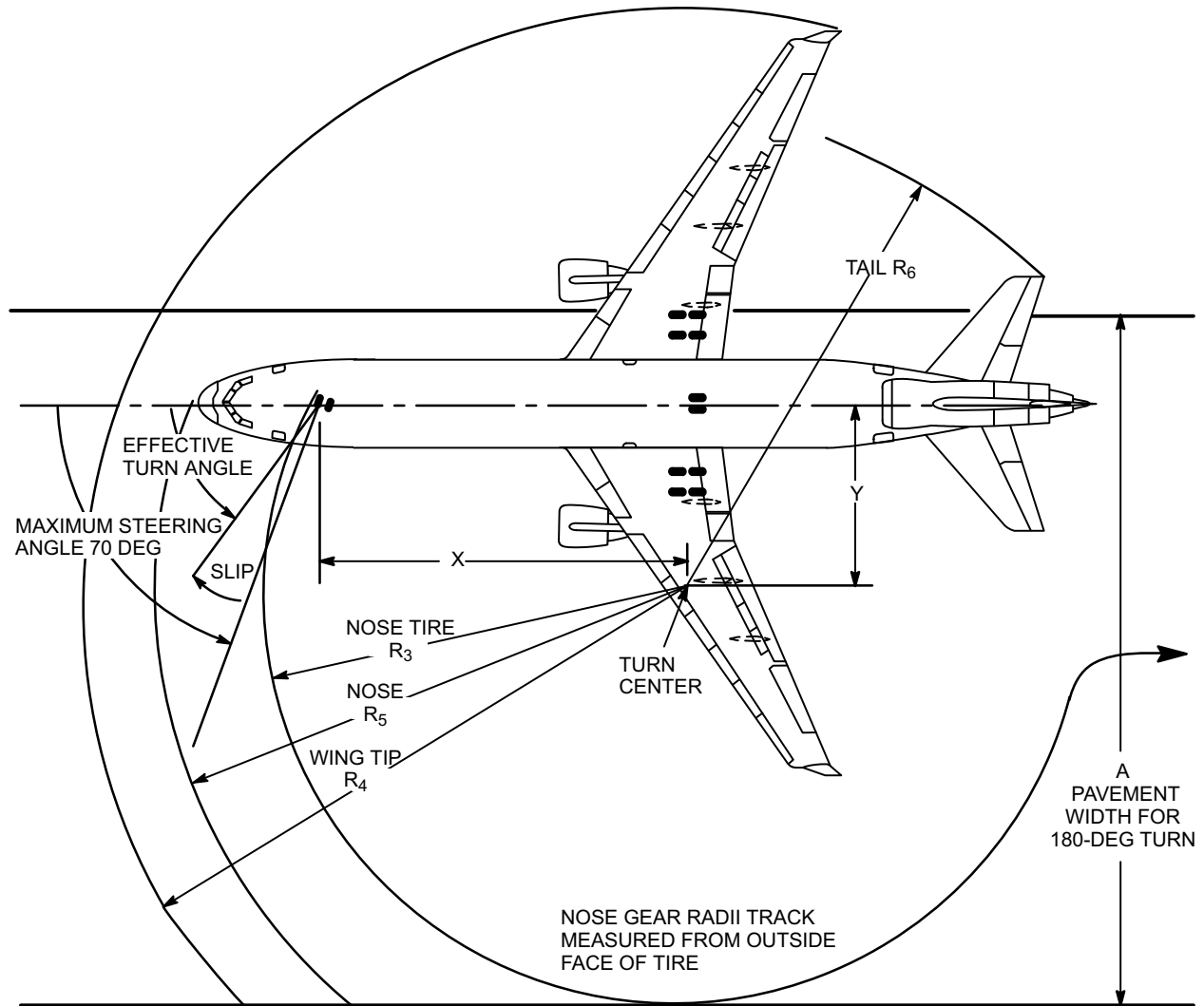

1 **NORMAL TURNS**  
 SYMMETRICAL THRUST AND NO DIFFERENTIAL BRAKING. SLOW CONTINUOUS TURN. AFT CENTER OF GRAVITY AT MAX RAMP WEIGHT

2 **LIGHTLY BRAKED TURN**  
 UNSYMMETRICAL THRUST AND LIGHT DIFFERENTIAL BRAKING. SLOW CONTINUOUS TURN. AFT CENTER OF GRAVITY AT MAX RAMP WEIGHT

3 **MINIMUM RECOMMENDED RADIUS TO AVOID EXCESSIVE TIRE WEAR. LIMITED BY 8-DEG MAIN GEAR TIRE SCRUB**

TYPE TURN	EFFECTIVE TURN ANGLE	TIRE SLIP ANGLE	X FT/m	Y FT/m	A FT/m	R <sub>3</sub> FT/m	R <sub>4</sub> FT/m	R <sub>5</sub> FT/m	R <sub>6</sub> FT/m
1	60.8 DEG	9.2 DEG	81.2	45.3	160.6	94.7	136.4	118.1	111.9
			24.7	13.8	49.0	28.9	41.6	36.0	34.1
2	72.0 DEG	-2.0 DEG	81.6	26.5	134.6	87.5	118.5	112.6	100.0
			24.9	8.1	41.0	26.7	36.1	34.3	30.5
3	-	-	81.2	42.1	155.8	93.1	133.4	116.9	109.8
			24.7	12.8	47.5	28.4	40.6	35.6	33.5

Chap4-Text

### 4.3 MINIMUM TURNING RADII MODEL MD-11

REV D

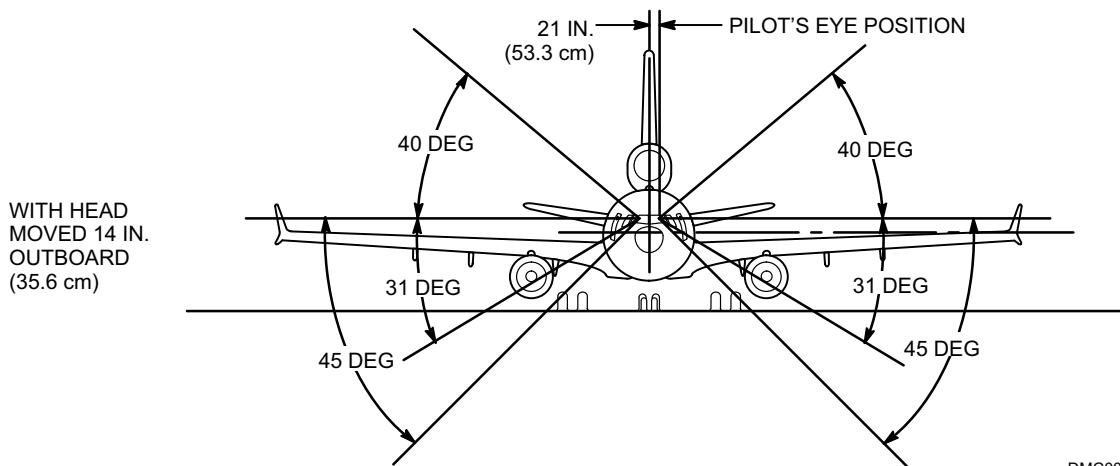
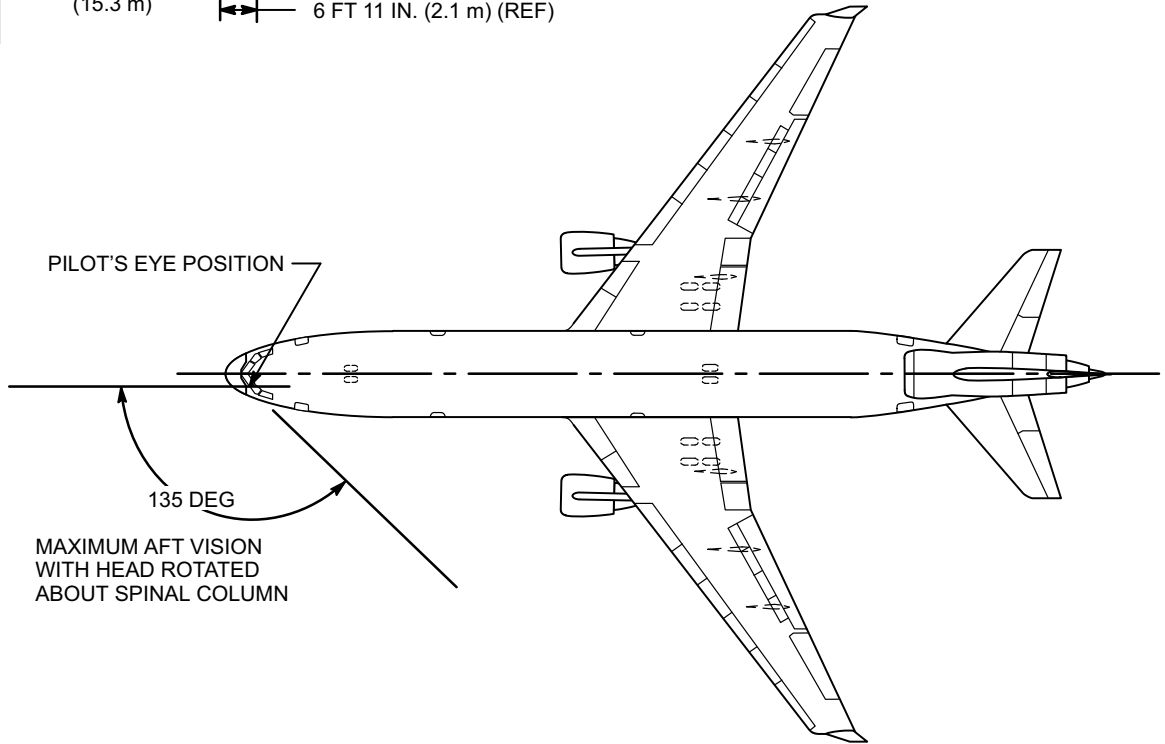
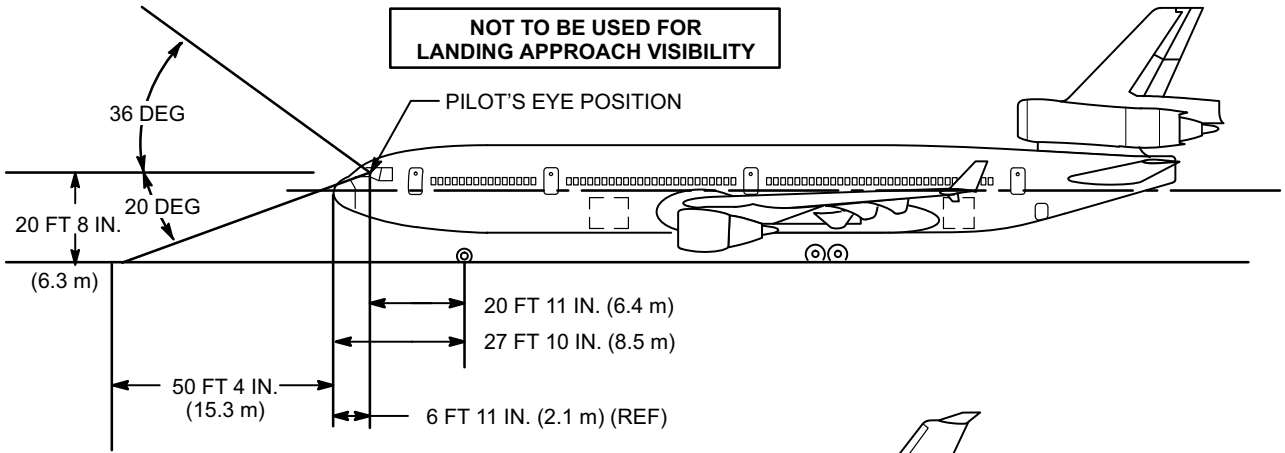

DMC005-42

**4.4 VISIBILITY FROM COCKPIT IN STATIC POSITION  
MODEL MD-11**

REV B

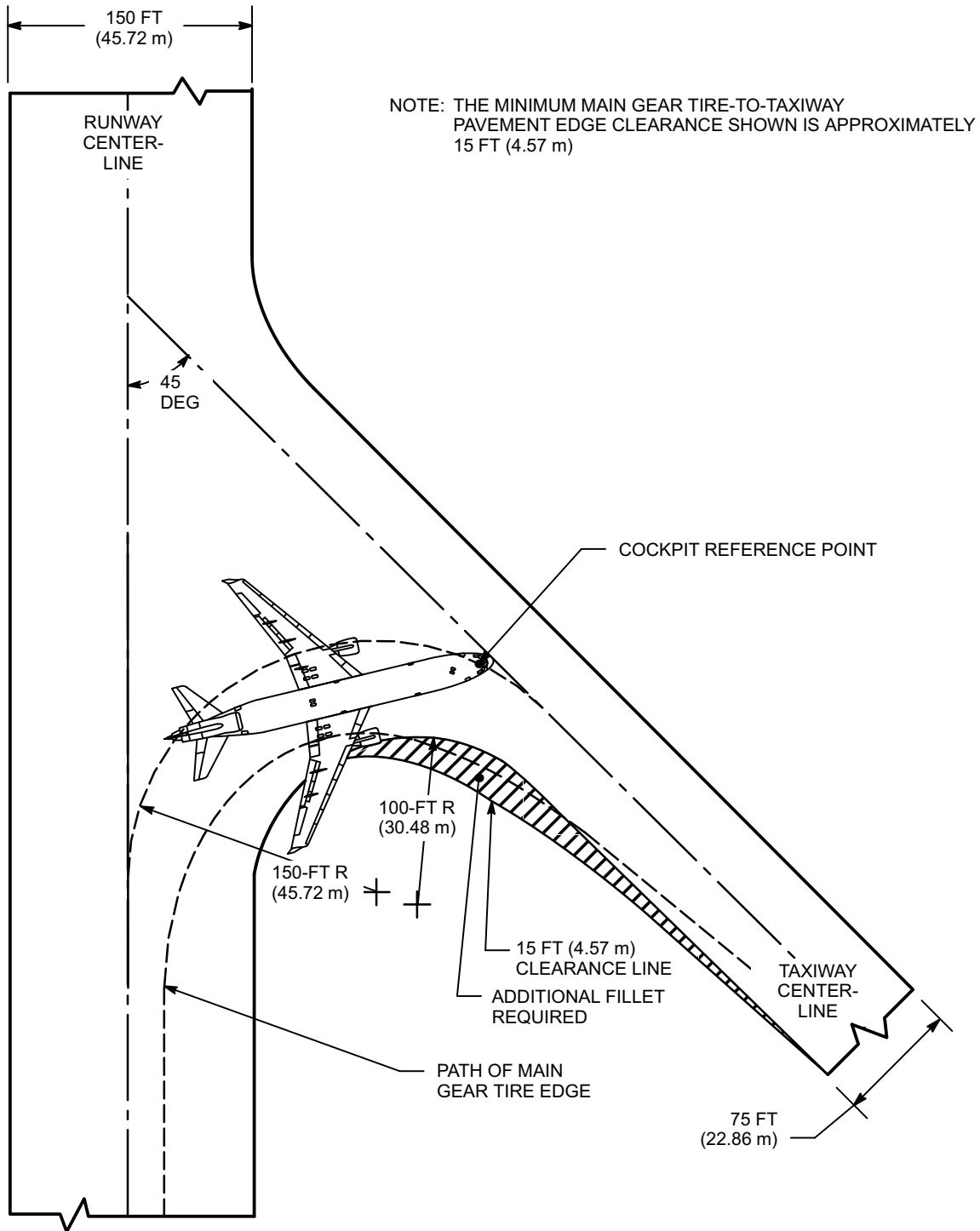

DMC005-89

**4.5 RUNWAY AND TAXIWAY TURN PATHS**  
**4.5.1 MORE THAN 90-DEG TURN – RUNWAY TO TAXIWAY**  
**MANEUVERING METHOD – COCKPIT OVER CENTERLINE**  
**MODEL MD-11**

REV B

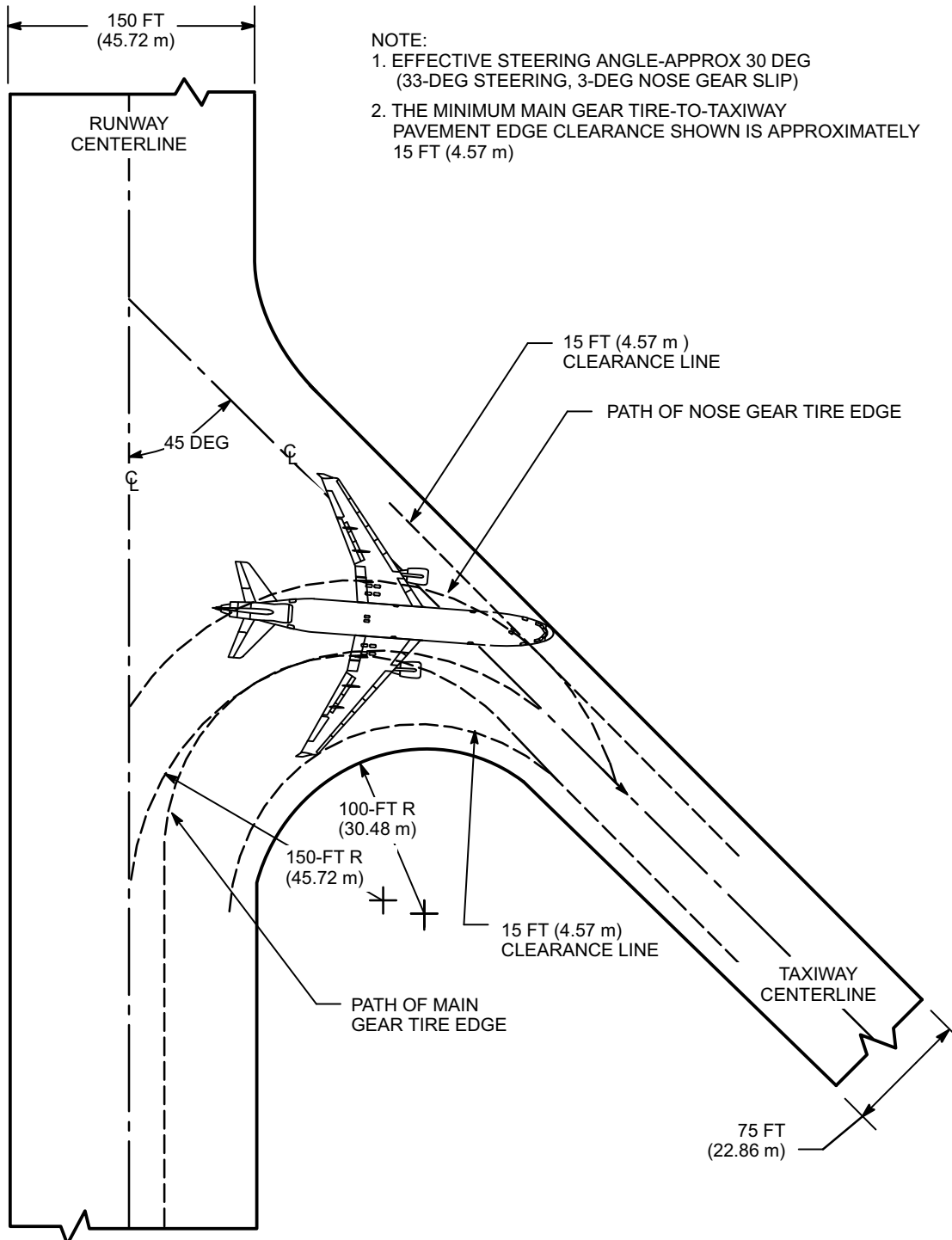

DMC005-88

**4.5.2 MORE THAN 90-DEGREE TURN – RUNWAY TO TAXIWAY  
 MANEUVERING METHOD – JUDGMENTAL OVERSTEERING  
 MODEL MD-11**

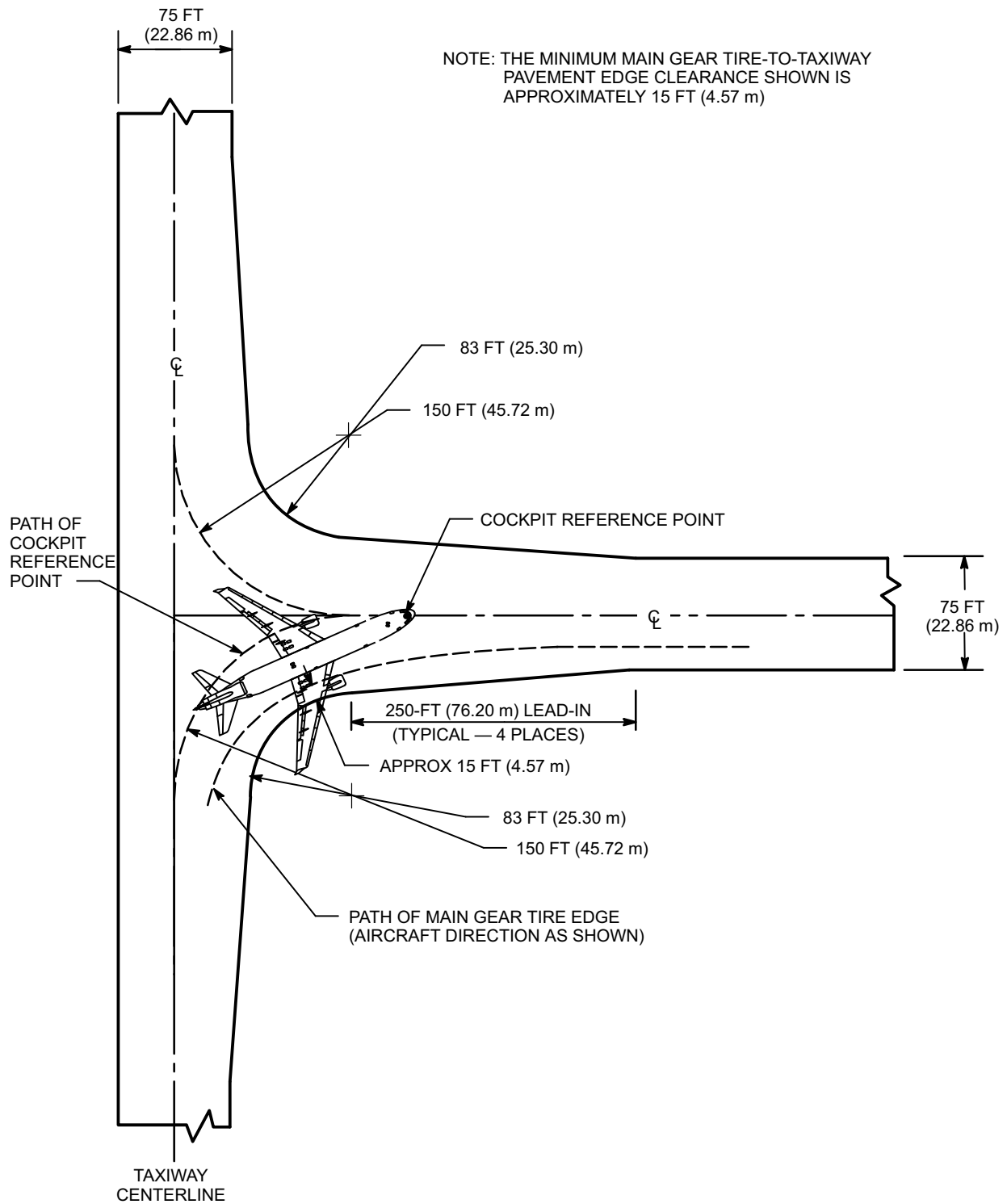

DMC005-90

**4.5.3 90-DEGREE TURN – TAXIWAY TO TAXIWAY  
MANEUVERING METHOD — COCKPIT OVER CENTERLINE  
MODEL MD-11**

REV D



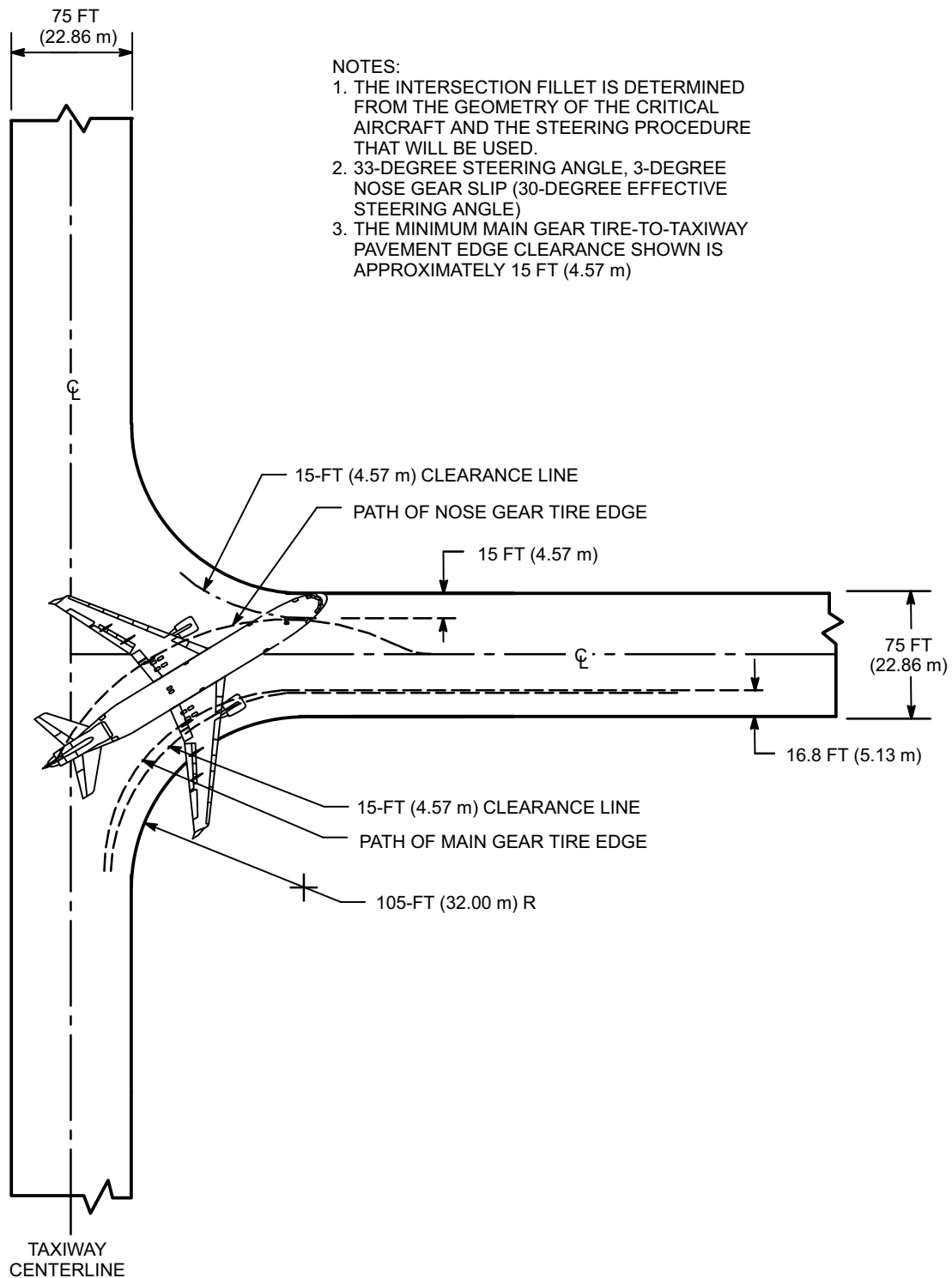

DMC005-91

**4.5.4 90-DEGREE TURN – TAXIWAY TO TAXIWAY  
MANEUVERING METHOD – JUDGMENTAL OVERSTEERING  
MODEL MD-11**

REV B

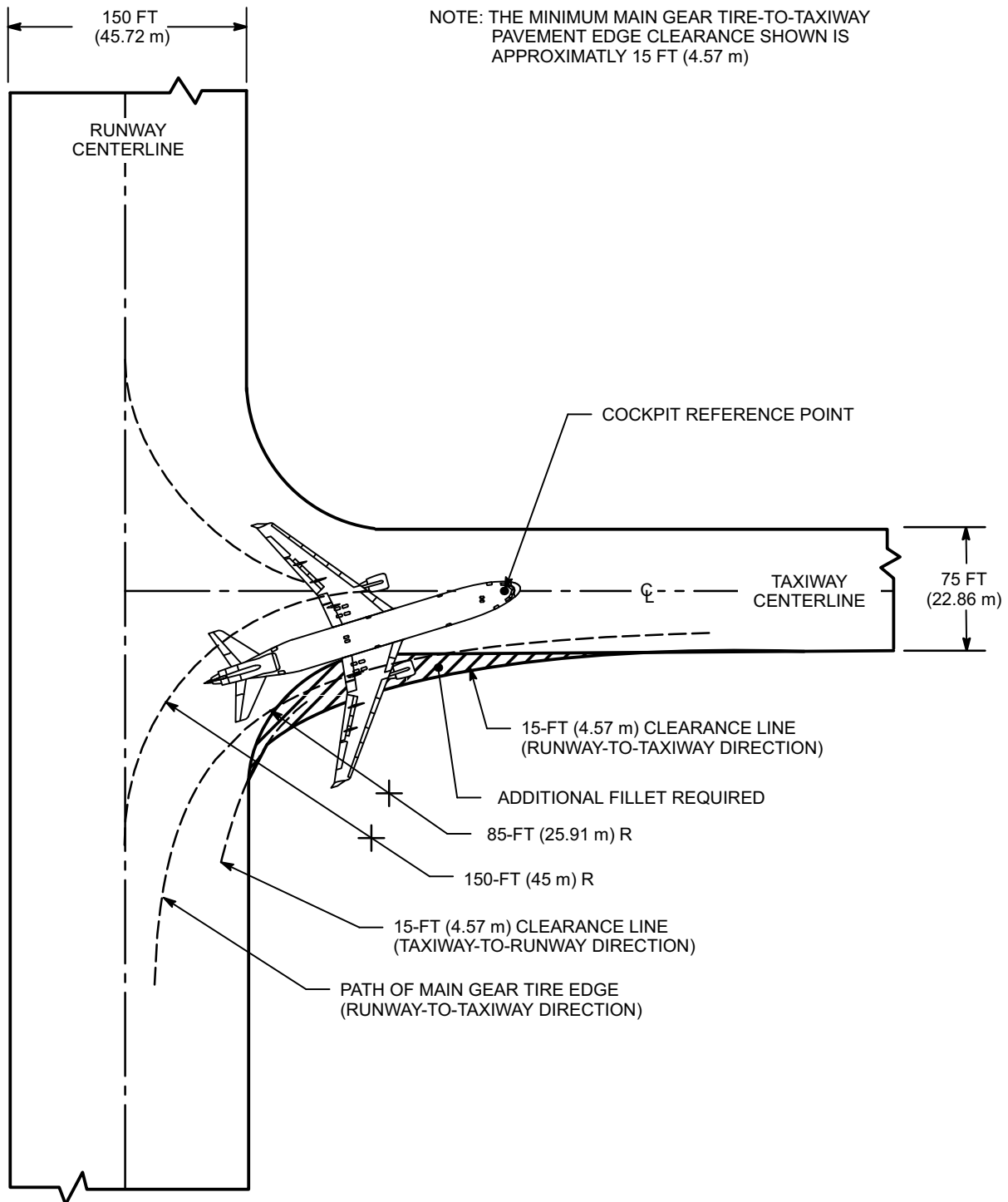

DMC005-92

**4.5.5 90-DEGREE TURN – RUNWAY TO TAXIWAY  
MANEUVERING METHOD — COCKPIT OVER CENTERLINE  
MODEL MD-11**

NOTE: THE MINIMUM MAIN GEAR TIRE-TO-PAVEMENT EDGE CLEARANCE SHOWN IS APPROXIMATELY 15 FT (4.57 m)

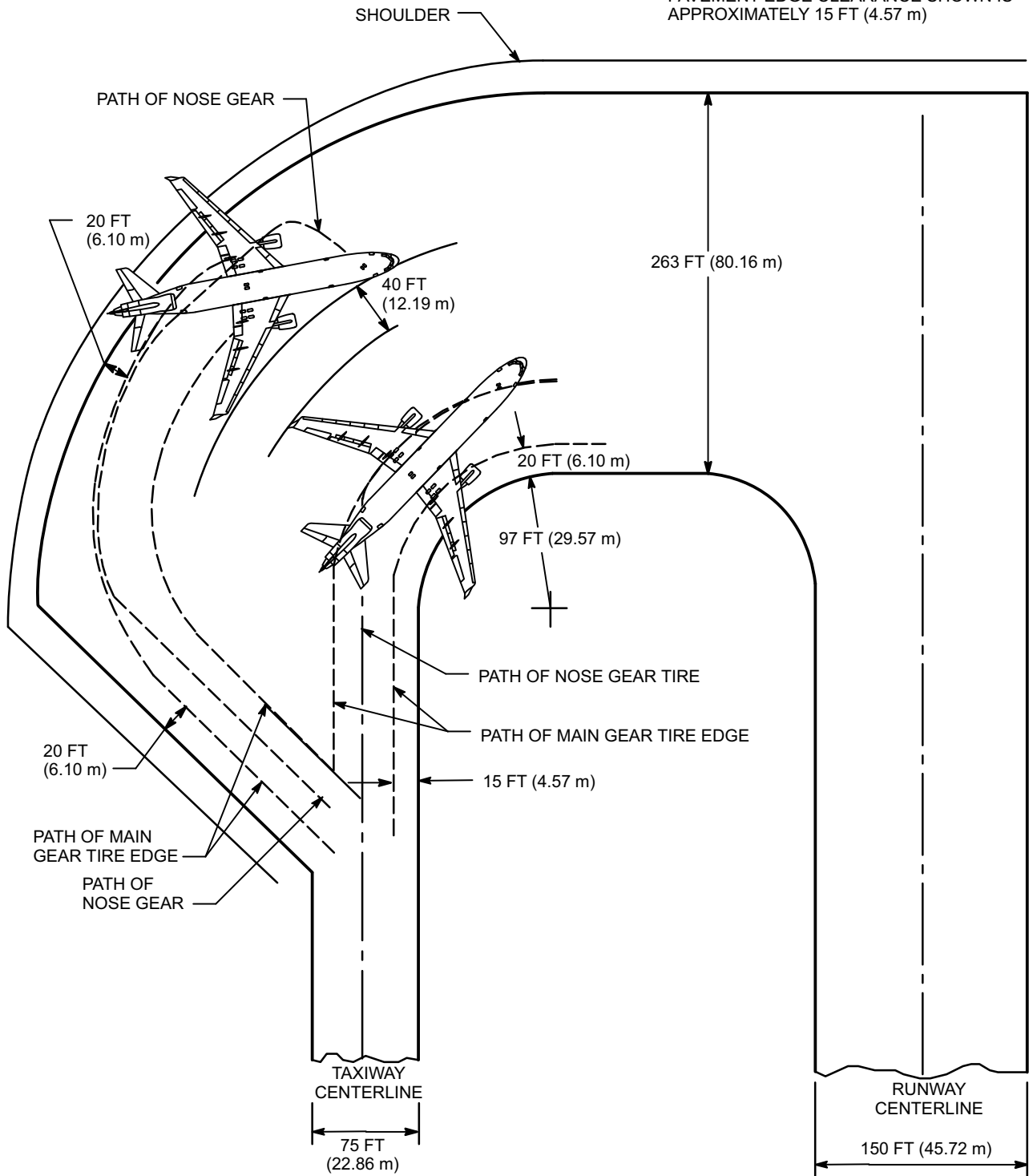

DMC005-93

#### 4.6 RUNWAY HOLDING BAY (APRON) MODEL MD-11

## **5.0 TERMINAL SERVICING**

- 5.1 Airplane Servicing Arrangement (Typical)**
- 5.2 Terminal Operations, Turnaround Station**
- 5.3 Terminal Operations, En Route Station**
- 5.4 Ground Service Connections**
- 5.5 Engine Starting Pneumatic Requirements**
- 5.6 Ground Pneumatic Power Requirements**
- 5.7 Preconditioned Airflow Requirements**
- 5.8 Ground Towing Requirements**

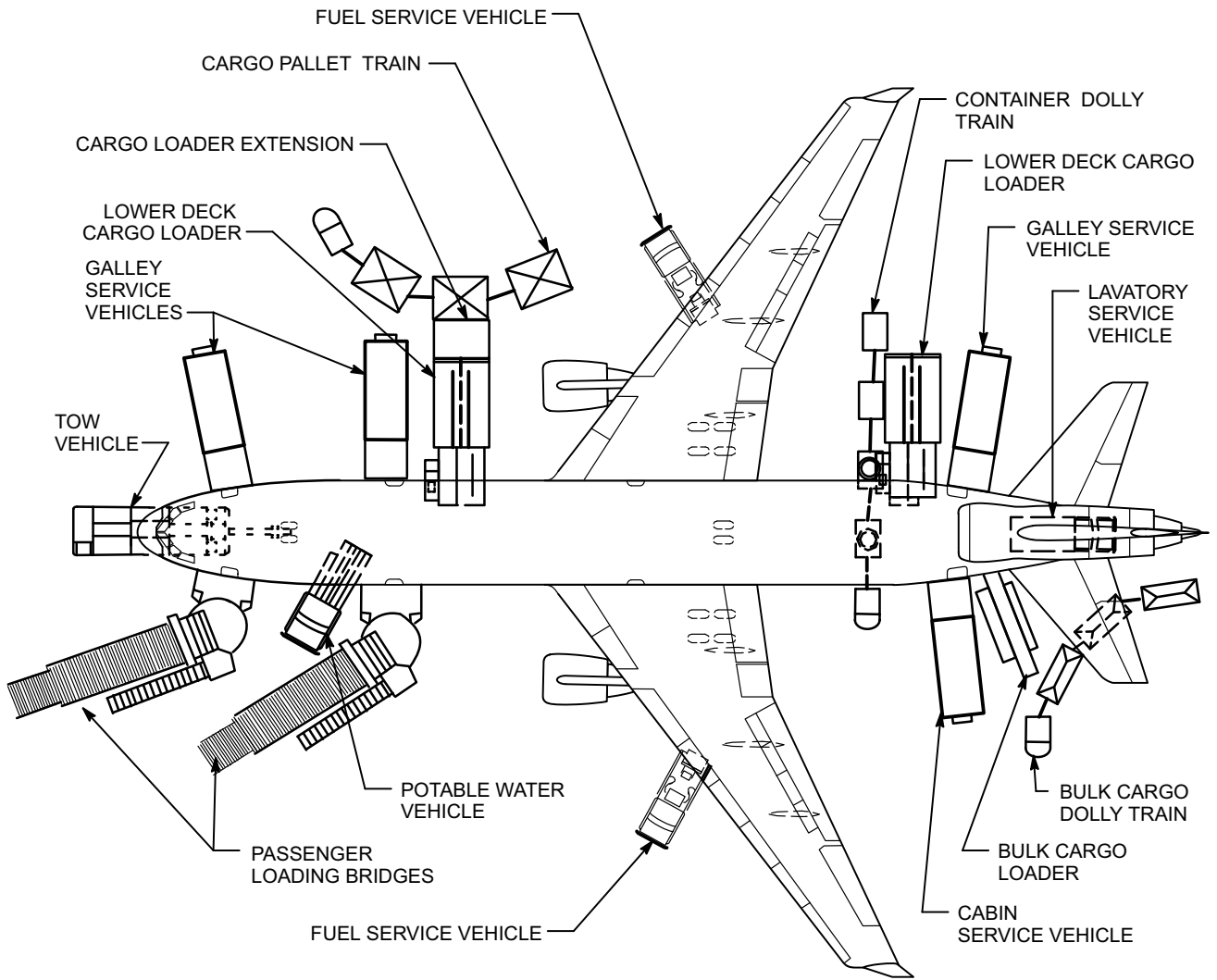

NOTE: THE AIRCRAFT AUXILIARY POWER UNIT SUPPLIES ELECTRICAL, PNEUMATIC AIR, AND PRECONDITIONED AIR.

DMC005-43

**5.0 TERMINAL SERVICING**  
**5.1 AIRPLANE SERVICING ARRANGEMENT (TYPICAL)**  
**5.1.1 AIRPLANE SERVICING ARRANGEMENT — TYPICAL TURNAROUND**  
**MODEL MD-11**

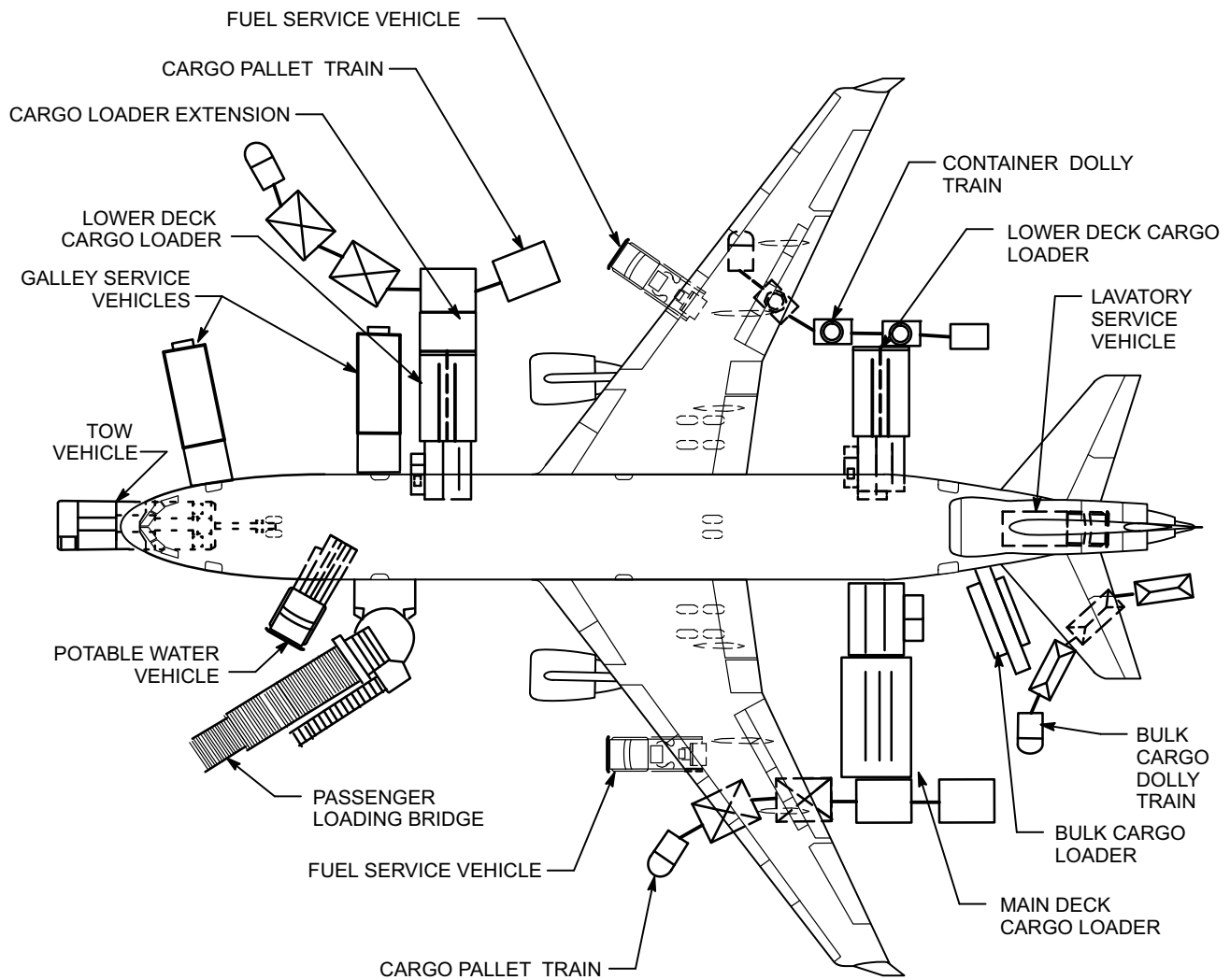

NOTE: THE AIRCRAFT AUXILIARY POWER UNIT SUPPLIES ELECTRICAL, PNEUMATIC AIR, AND PRECONDITIONED AIR.

DMC005-44

**5.0 TERMINAL SERVICING**  
**5.1.2 AIRPLANE SERVICING ARRANGEMENT — TYPICAL TURNAROUND**  
**MODEL MD-11 COMBI**

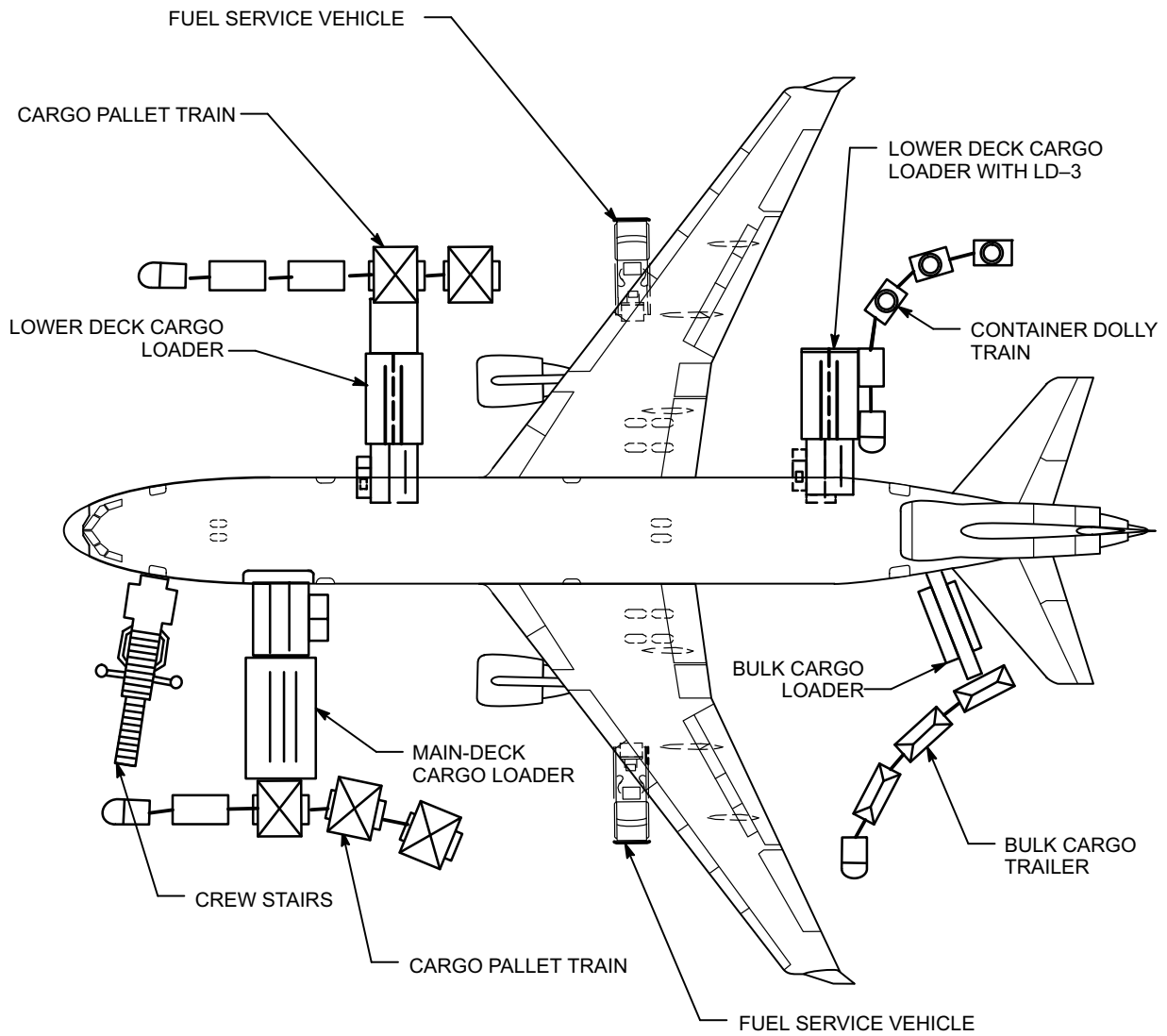

NOTE: THE AIRCRAFT AUXILIARY POWER UNIT SUPPLIES ELECTRICAL, PNEUMATIC, AND PRECONDITIONED AIR

DMC005-45

**5.0 TERMINAL SERVICING**  
**5.1.3 AIRLINE SERVICING ARRANGEMENT — TYPICAL TURNAROUND**  
**MODEL MD-11F/CF**

REV D

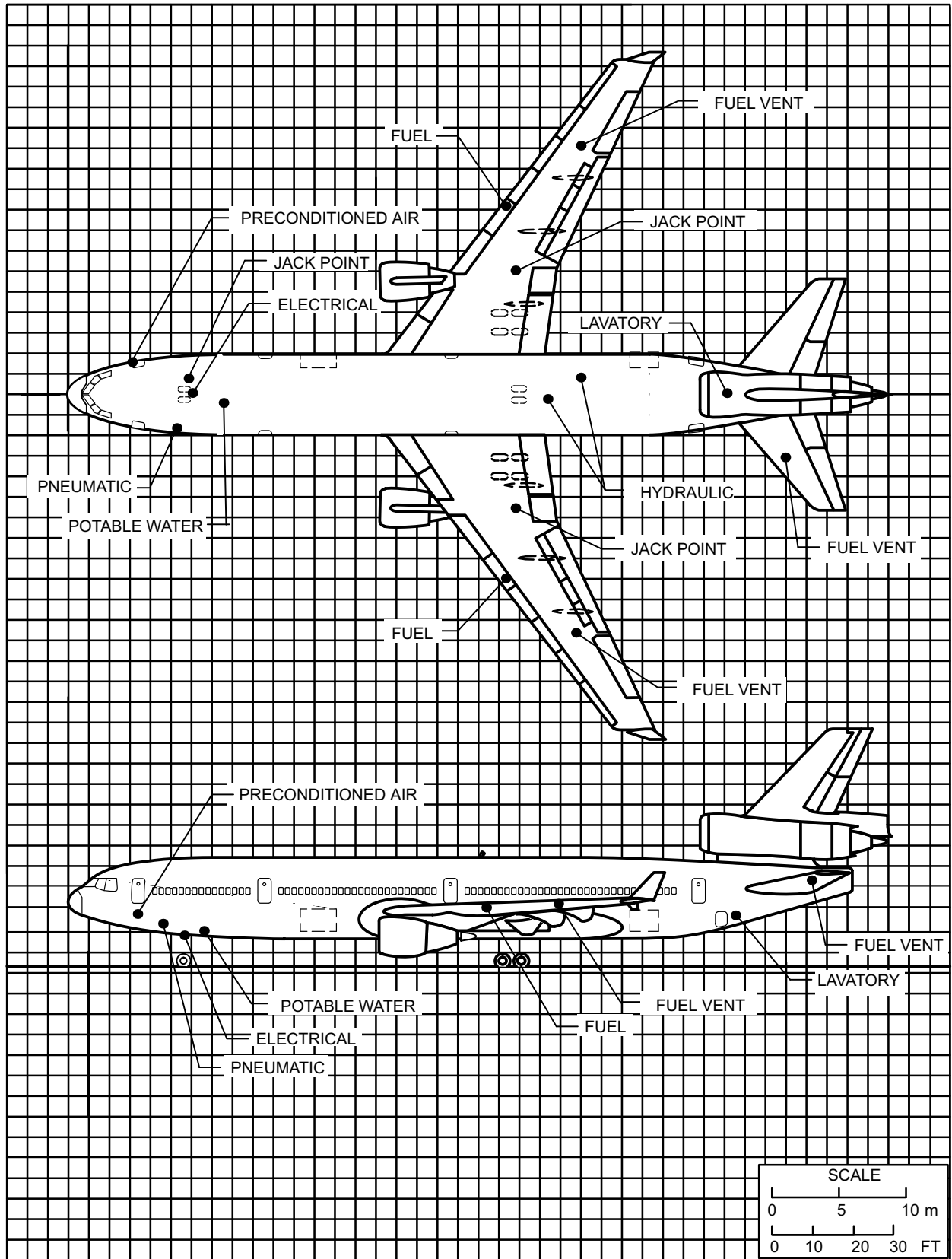

**5.4 GROUND SERVICE CONNECTIONS  
MODEL MD-11**

DMC005-48



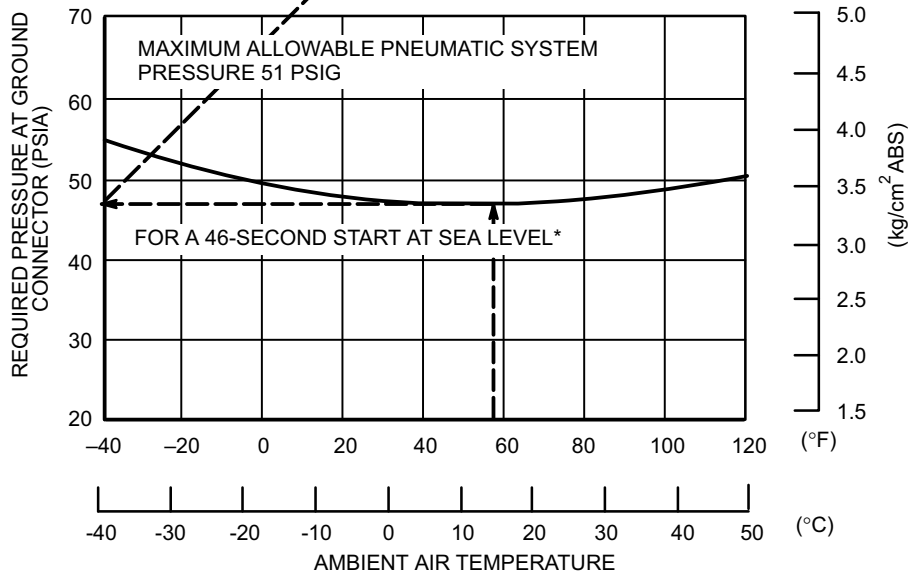
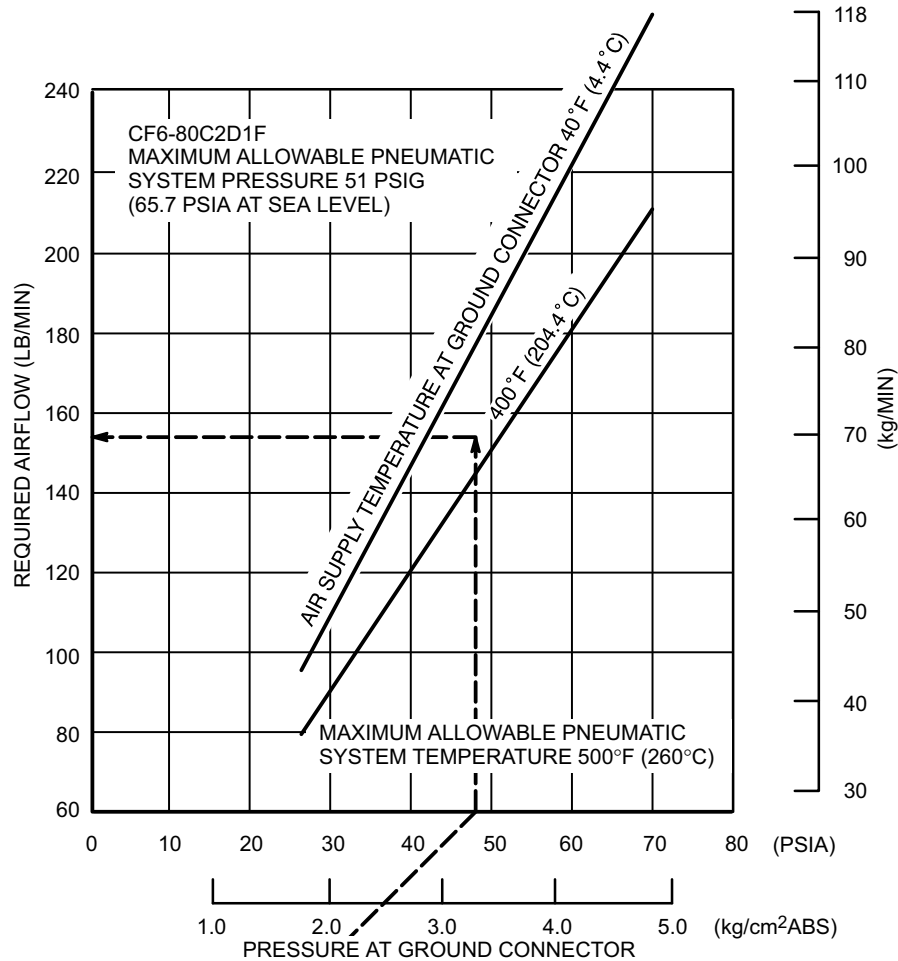

\* THERE IS NO SATISFACTORY DEFINITION FOR "REQUIRED PRESSURE AT GROUND CONNECTOR" SO THAT A SINGLE LINE CAN BE DEPICTED. THE LINE DEPICTED IS FOR A 46-SECOND START TIME, WHICH IS AN ARBITRARY VALUE.

DMC005-49

## 5.5 ENGINE STARTING PNEUMATIC REQUIREMENTS MODEL MD-11 GE ENGINE

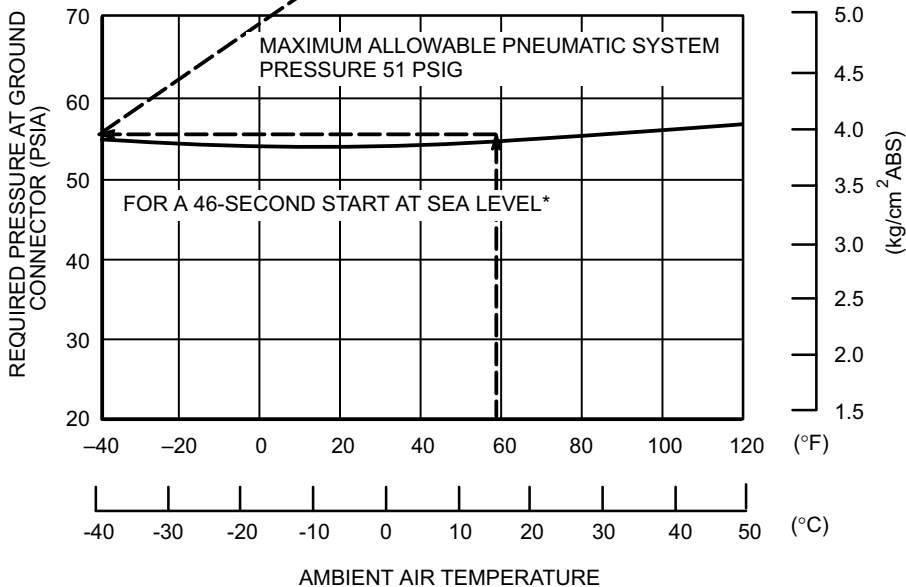
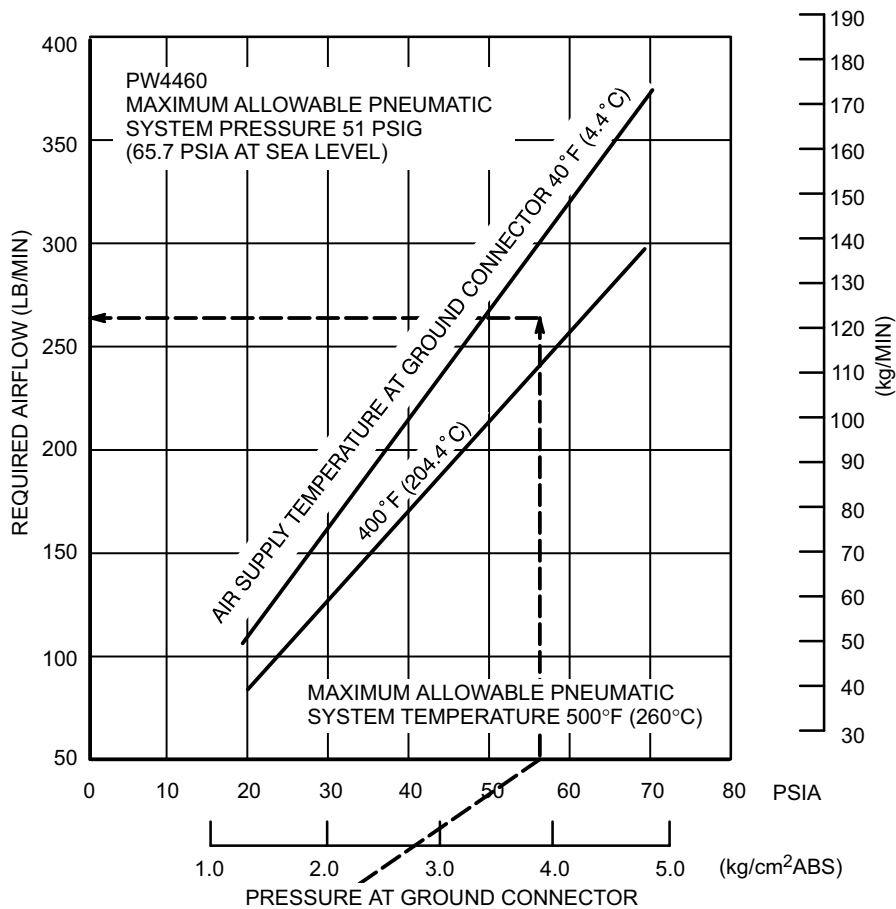

\* THERE IS NO SATISFACTORY DEFINITION FOR "REQUIRED PRESSURE AT GROUND CONNECTOR" SO THAT A SINGLE LINE CAN BE DEPICTED. THE LINE DEPICTED IS FOR A 46-SECOND START TIME, WHICH IS AN ARBITRARY VALUE.

DMC005-50

## 5.5 ENGINE STARTING PNEUMATIC REQUIREMENTS MODEL MD-11 P&W ENGINE

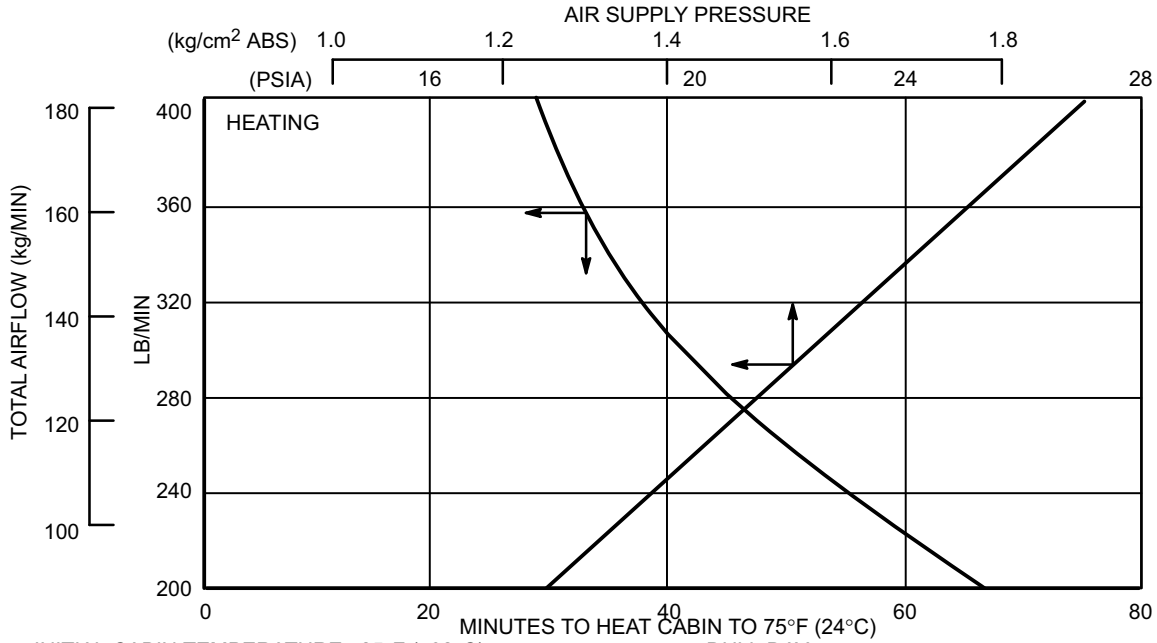

- INITIAL CABIN TEMPERATURE -25°F (-32°C)
- OUTSIDE AIR TEMPERATURE -40°F (-40°C)
- MAX TEMPERATURE AT GROUND CONN 440°F (227°C)
- MIN TEMPERATURE NOT LESS THAN 200°F (93°C) ABOVE O.A.T
- DOORS CLOSED
- DULL DAY
- NO CABIN OCCUPANTS OR ELECTRICAL LOAD
- MAX ALLOWABLE SUPPLY PRESSURE 45 PSIG
- BOTH GROUND CONNECTIONS USED
- THREE-PACK OPERATION

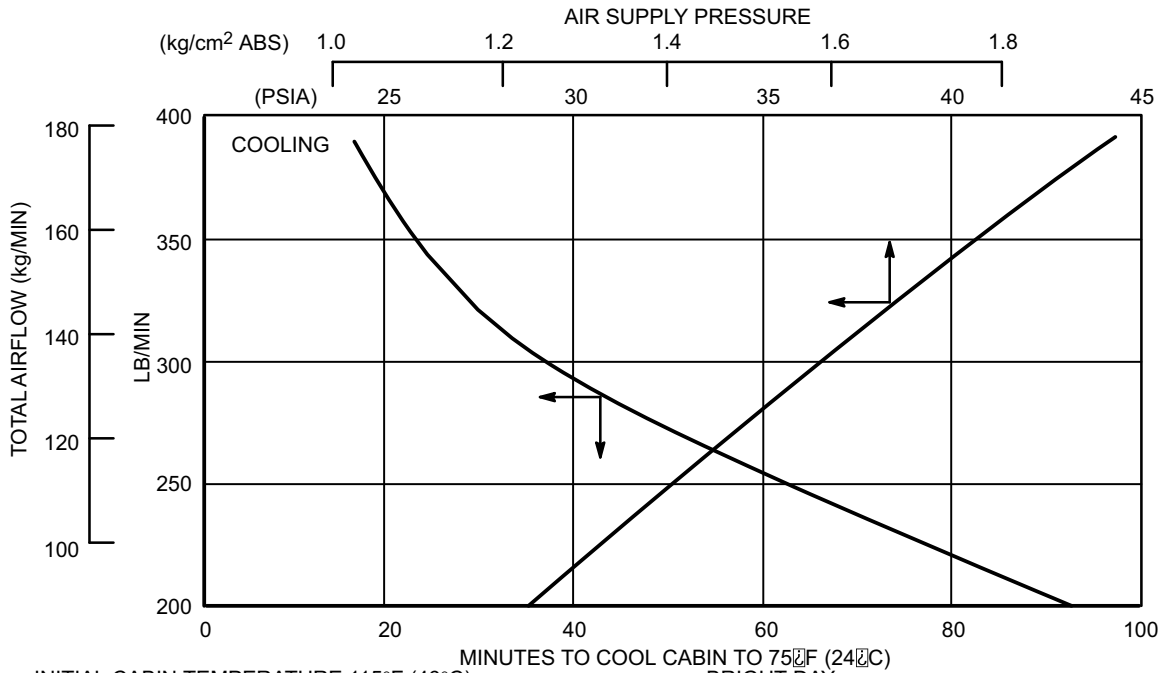

- INITIAL CABIN TEMPERATURE 115°F (46°C)
- OUTSIDE AIR TEMPERATURE 103°F (40°C) REL HUM 42%
- MAX TEMPERATURE AT GROUND CONN 440°F (227°C)
- MIN TEMPERATURE NOT LESS THAN 200°F (93°C) ABOVE O.A.T
- DOORS CLOSED
- BRIGHT DAY
- NO CABIN OCCUPANTS OR ELECTRICAL LOAD
- MAX ALLOWABLE SUPPLY PRESSURE 45 PSIG
- BOTH GROUND CONNECTIONS USED
- THREE-PACK OPERATION

## 5.6 GROUND PNEUMATIC POWER REQUIREMENTS MODEL MD-11

DMC005-51

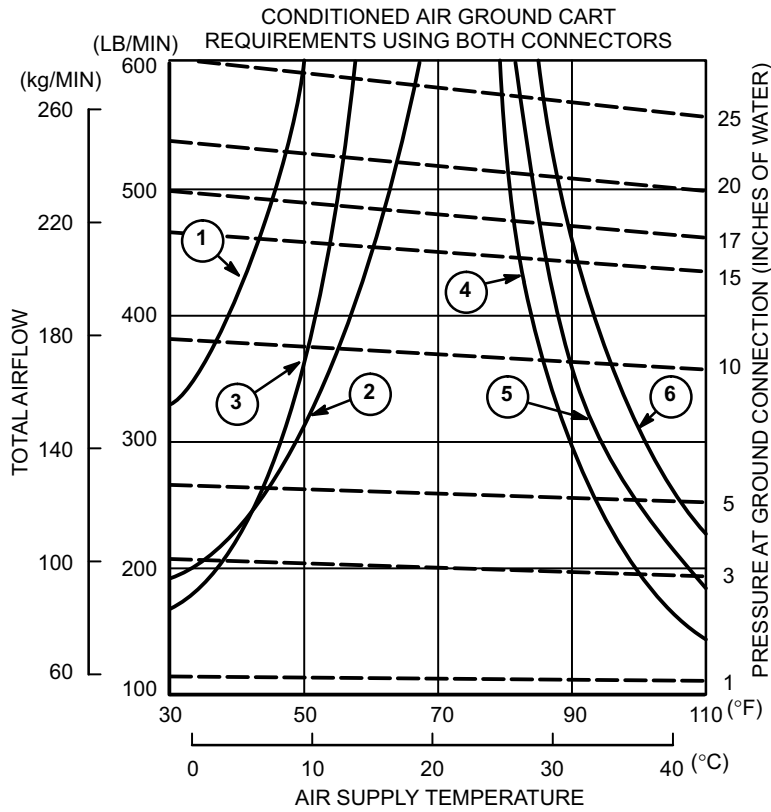

- ① CABIN AT 75°F (24°C), 410 OCCUPANTS, BRIGHT DAY (SOLAR IRRADIATION), 103°F (39°C) DAY
- ② SAME AS 1 EXCEPT CABIN AT 85°F (29°C)
- ③ SAME AS 1 EXCEPT CABIN AT 70°F (21°C), NO CABIN OCCUPANTS, FIVE CREW MEMBERS ONLY
- ④ CABIN AT 70°F (21°C), 50 CABIN OCCUPANTS, OVERCAST DAY (NO SOLAR IRRADIATION), 0°F (-18°C) DAY
- ⑤ SAME AS 4 EXCEPT -20°F (-29°C) DAY
- ⑥ SAME AS 4 EXCEPT -40°F (-40°C) DAY

MAXIMUM ALLOWABLE TEMPERATURE  
190°F (88°C)

MAXIMUM ALLOWABLE PRESSURE AT  
GROUND CONNECTION (25 INCHES WATER)

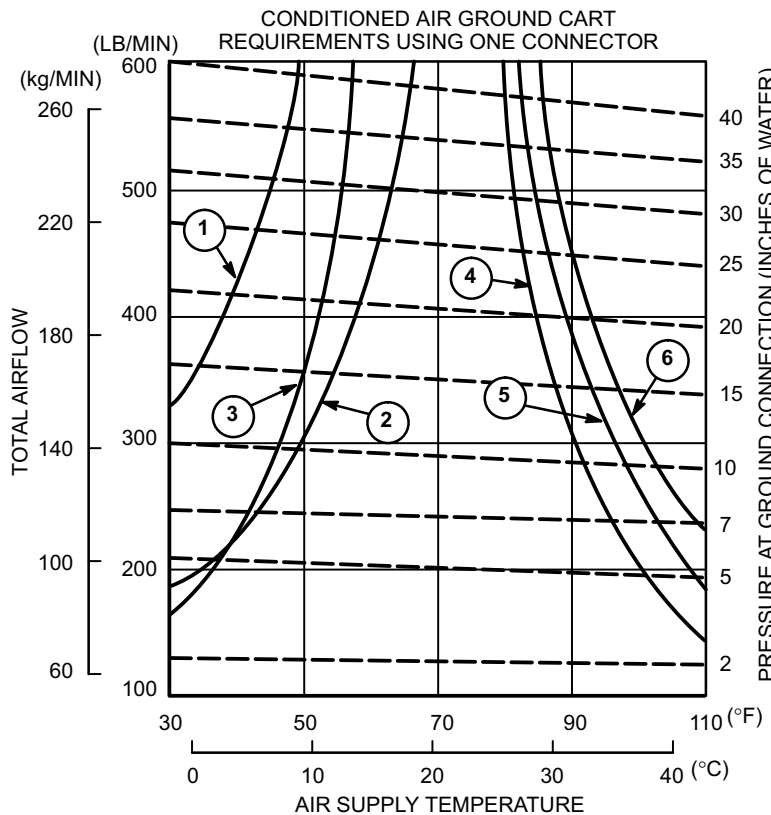

## 5.7 PRECONDITIONED AIRFLOW REQUIREMENTS MODEL MD-11

DMC005-53-54

## **6.0 OPERATING CONDITIONS**

### **6.1 Jet Engine Exhaust Velocities and Temperatures**

### **6.2 Airport and Community Noise**

#### 6.1.4 Jet Engine Exhaust Temperature (MD-11, All Engine Models)

Jet engine exhaust temperature contour lines have not been presented because the adverse effects of exhaust temperature at any given position behind the aircraft fitted with these high-bypass engines are considerably less than the effects of exhaust velocity.

## 6.2 Airport and Community Noise

Airport noise is of major concern to the airport and community planner. The airport is a major element of the community's transportation system and, as such, is vital to its growth. However, the airport must also be a good neighbor, and this can be accomplished only with proper planning. Since aircraft noise extends beyond the boundaries of the airport, it is vital to consider the impact on surrounding communities. Many means have been devised to provide the planner with a tool to estimate the impact of airport operations. Too often they oversimplify noise to the point where the results become erroneous. Noise is not a simple subject; therefore, there are no simple answers.

The cumulative noise contour is an effective tool. However, care must be exercised to ensure that the contours, used correctly, estimate the noise resulting from aircraft operations conducted at an airport.

The size and shape of the single-event contours, which are inputs into the cumulative noise contours, are dependent upon numerous factors. They include:

1. Operational Factors
  - (a) Aircraft Weight — Aircraft weight is dependent on distance to be traveled, en route winds, payload, and anticipated aircraft delay upon reaching the destination.
  - (b) Engine Power Settings — The rates of ascent and descent and the noise levels emitted at the source are influenced by the power setting used.
  - (c) Airport Altitude — Higher airport altitude will affect engine performance and thus can influence noise.
2. Atmospheric Conditions — Sound Propagation
  - (a) Wind — With stronger headwinds, the aircraft can take off and climb more rapidly relative to the ground. Also, winds can influence the distribution of noise in surrounding communities.
  - (b) Temperature and Relative Humidity — The absorption of noise in the atmosphere along the transmission path between the aircraft and the ground observer varies with both temperature and relative humidity.
3. Surface Condition — Shielding, Extra Ground Attenuation (EGA)

**Terrain** — If the ground slopes down after takeoff or up before landing, noise will be reduced since the aircraft will be at a higher altitude above the ground. Additionally, hills, shrubs, trees, and large buildings can act as sound buffers.

All of these factors can alter the shape and size of the contours appreciably. To demonstrate the effect of some of these factors, estimated noise level contours for two different operating conditions are shown below. These contours reflect a given noise level upon a ground level plane at runway elevation.

As indicated by these data, the contour size varies substantially with operating and atmospheric conditions. Most aircraft operations are, of course, conducted at less than maximum gross weights because average flight distances are much shorter than maximum aircraft range capability and average load factors are less than 100 percent. Therefore, in developing cumulative contours for planning purposes, it is recommended that the airlines serving a particular city be contacted to provide operational information.

In addition, there are no universally accepted methods for developing aircraft noise contours or for relating the acceptability of specific noise zones to specific land uses. It is therefore expected that noise contour data for particular aircraft and the impact assessment methodology will be changing. To ensure that currently available information of this type is used in any planning study, it is recommended that it be obtained directly from the Office of Environmental Quality in the Federal Aviation Administration in Washington, D.C.

It should be noted that the contours are shown here only to illustrate the impact of operating and atmospheric conditions and do not represent the single-event contour of the family of aircraft described in this document. It is expected that the cumulative contours will be developed as required by planners using the data and methodology applicable to their specific study.

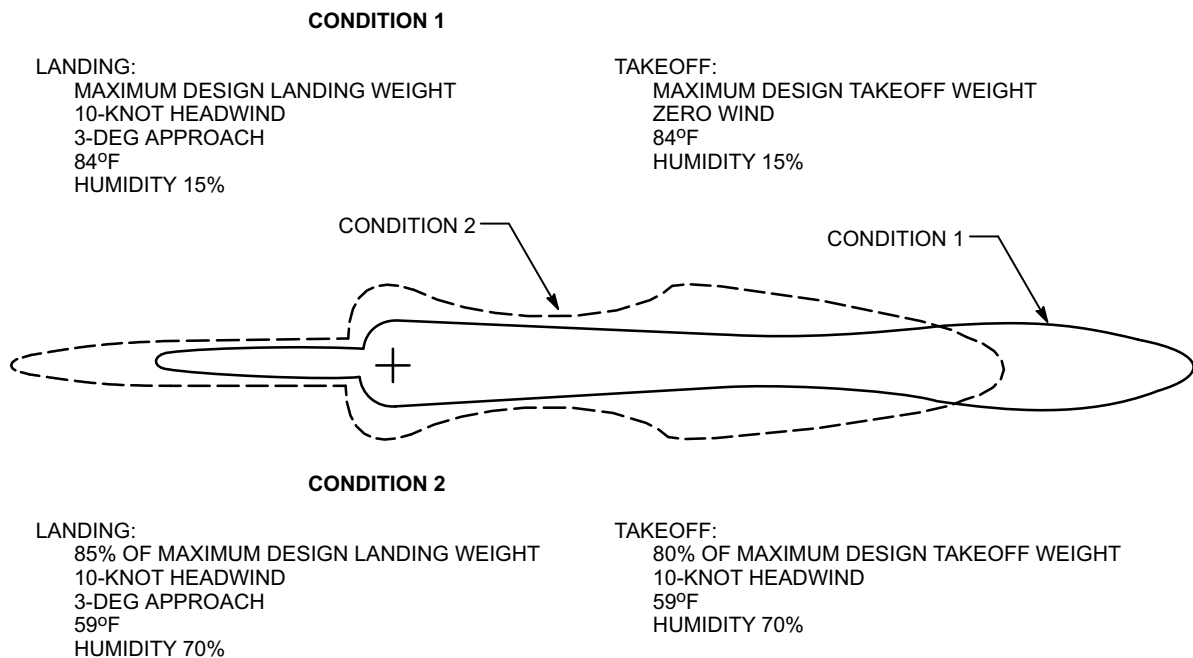



## **7.0 PAVEMENT DATA**

**7.1 General Information**

**7.2 Footprint**

**7.3 Maximum Pavement Loads**

**7.4 Landing Gear Loading on Pavement**

**7.5 Flexible Pavement Requirements**

**7.6 Flexible Pavement Requirements, LCN  
Conversion**

**7.7 Rigid Pavement Requirements**

**7.8 Rigid Pavement Requirements, LCN  
Conversion**

**7.9 ACN-PCN Reporting System; Flexible  
and Rigid Pavements**

## 7.0 PAVEMENT DATA

### 7.1 General Information

A brief description of the following pavement charts will facilitate their use for airport planning. Each airplane configuration is shown with a minimum range of four loads imposed on the main landing gear to aid in interpolation between the discrete values shown. All curves are plotted at constant specified tire pressure at the highest certified weight for each model.

Subsection 7.2 presents basic data on the landing gear footprint configuration, tire sizes, and tire pressures.

Subsection 7.3 lists maximum vertical and horizontal pavement loads at the tire ground interfaces for certain critical conditions.

Subsection 7.4 presents a chart showing static loads imposed on the main landing gear struts for the operational limits of the airplane. These main landing gear loads are used for interpreting the pavement design charts. All pavement requirements are based on the wing gear because the center gear is less demanding under normal conditions.

Subsection 7.5 presents a pavement requirement chart for flexible pavements. Flexible pavement design curves are based on the format and procedures set forth in Instruction Report No. S-77-1, Procedures for Development of CBR Design Curves, published in June 1977 by the U.S. Army Engineer Waterways Experiment Station, Soils and Pavements Laboratory, Vicksburg, Mississippi.

The following procedure is used to develop the flexible pavement curves:

1. Having established the scale for pavement depth at the bottom and the scale for CBR at the top, an arbitrary line is drawn representing 6,000 annual departures.
2. Values of the aircraft gross weight are then plotted.
3. Additional annual departure lines are drawn based on the load lines of the aircraft gross weights already established.
4. An additional line is drawn to represent 10,000 “coverages,” statistically the number of maximum stresses the aircraft causes in the pavement. This is used to calculate the flexible pavement Aircraft Classification Number.

Subsection 7.6 provides LCN conversion curves for flexible pavements. These curves have been plotted using procedures and curves in the International Civil Aviation Organization (ICAO) Aerodrome Design Manual, Part 3 — Pavements, Document 9157-AN/901, 1977. The same charts have plots of equivalent single-wheel load versus pavement thickness.

Subsection 7.7 provides rigid pavement design curves prepared with the use of the Westergaard equations in general accord with the relationships outlined in the 1955 edition of Design of Concrete Airport Pavement, published by the Portland Cement Association, 33 W. Grand Ave., Chicago, Illinois, but modified to the new format described in the 1968 Portland Cement Association publication, Computer Program for Airport Pavement Design by Robert G. Packard. The following procedure is used to develop the rigid pavement design curves.

1. Having established the scale for pavement thickness to the left and the scale for allowable working stress to the right, an arbitrary load line is drawn representing the main landing gear maximum weight to be shown.
2. All values of the subgrade modulus (K-values) are then plotted using the maximum load line, as shown.
3. Additional load lines for the incremental value of weight on the main landing gear are then established on the basis of the curve for  $K = 300 \text{ lb/in.}^3$  already established.

Subsection 7.8 presents LCN conversion curves for rigid pavements. These curves have been plotted using procedures and curves in the ICAO Aerodrome Design Manual, Part 3 — Pavements, Document 9157-AN/901, 1977. The same charts include plots of equivalent single-wheel load versus radius of relative stiffness. The LCN requirements are based on the condition of center-of-slab loading. Radii of relative stiffness values are obtained from Subsection 7.8.1.

Subsection 7.9 provides ACN data prepared according to the ACN-PCN system described in Aerodromes, Annex 14 to the Convention on International Civil Aviation. ACN is the Aircraft Classification Number and PCN is the corresponding Pavement Classification Number.

ACN-PCN provides a standardized international airplane/pavement rating system replacing the various S, T, TT, LCN, AUW, ISWL, etc., rating systems used throughout the world. An aircraft having an ACN equal to or less than the PCN can operate without restriction on the pavement. Numerically, the ACN is two times the derived single-wheel load expressed in thousands of kilograms, where the load is on a single tire inflated to 1.25 MPa (181 psi) that would have the same pavement requirements as the aircraft. Computationally, the ACN-PCN system uses PCA program PDILB for rigid pavements and S-77-1 for flexible pavements to calculate ACN values. The method of pavement evaluation is the responsibility of the airport, with the results of its evaluation presented as follows:

REPORT EXAMPLE: PCN 80/R/B/W/T

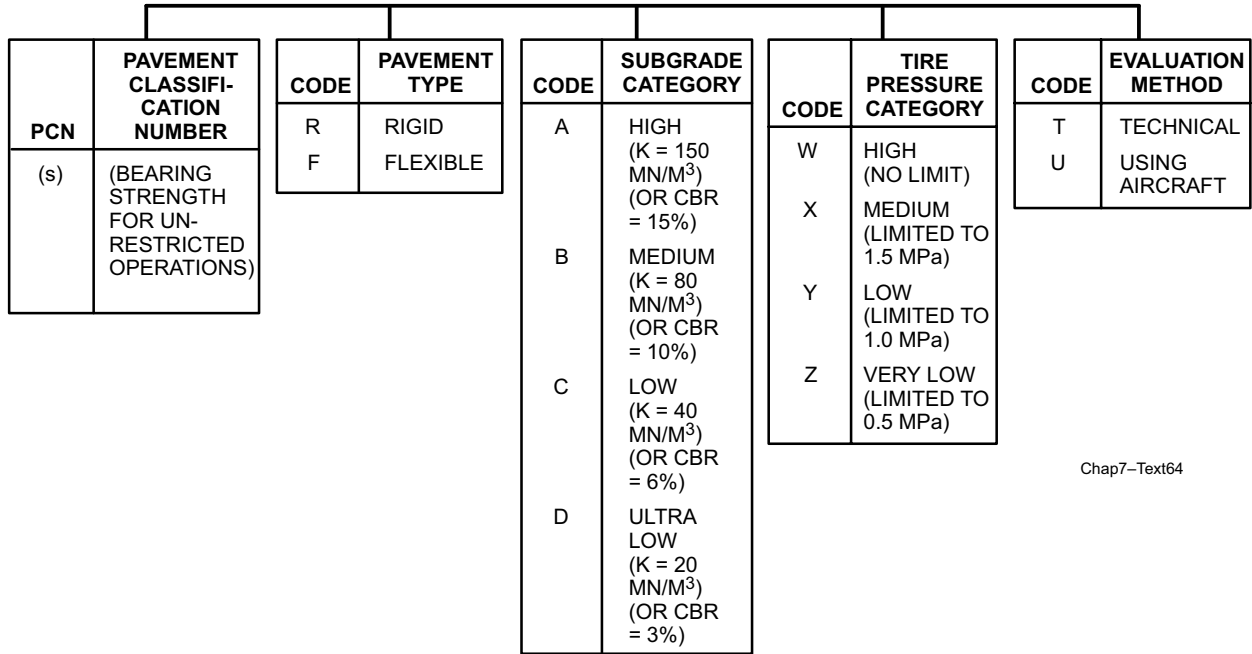

Chap7--Text64

MAXIMUM RAMP WEIGHT	628,000 LB (284,860 kg)
PERCENT OF WEIGHT ON MAIN GEAR	SEE SECTION 7.4
NOSE TIRE SIZE	40 x 15.5 — 16
NOSE TIRE PRESSURE	180 PSI (12.7 kg/cm <sup>2</sup> )
WING AND CENTER GEAR TIRE SIZE	H54 x 21.0 — 24
WING GEAR TIRE PRESSURE	205 PSI (14.4 kg/cm <sup>2</sup> )
CENTER GEAR TIRE PRESSURE	180 PSI (12.7 kg/cm <sup>2</sup> )

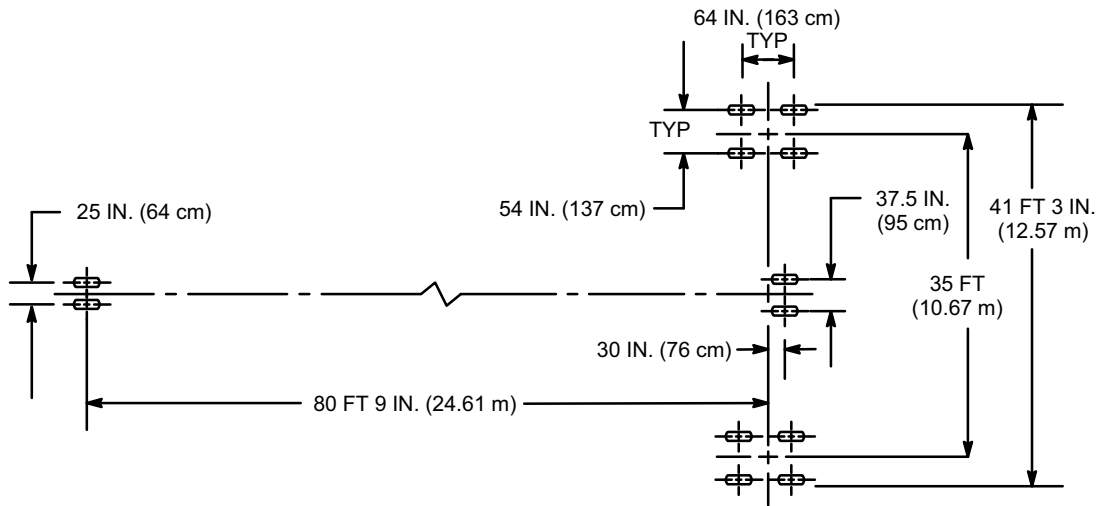

DMC005-65

## 7.2 FOOTPRINT MODEL MD-11

REV D

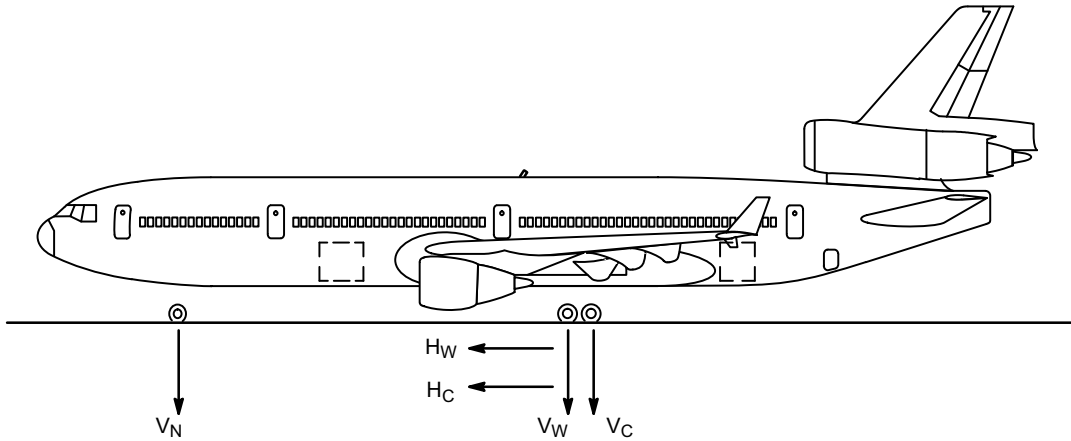

PAVEMENT LOADS FOR CRITICAL COMBINATIONS OF WEIGHT AND CG POSITIONS  
 $V_N$  = VERTICAL NOSE GEAR GROUND LOAD PER STRUT  
 $V_W$  = VERTICAL WING GEAR GROUND LOAD PER STRUT  
 $V_C$  = VERTICAL CENTER GEAR GROUND LOAD PER STRUT  
 $H_W$  = HORIZONTAL WING GEAR GROUND LOAD PER STRUT FROM BRAKING  
 $H_C$  = HORIZONTAL CENTER GEAR GROUND LOAD PER STRUT FROM BRAKING

MODEL MD-11	RAMP WEIGHT	NOSE GEAR (1) FORWARD CG		WING GEAR (2) AFT CG			CENTER GEAR (1) AFT CG		
		$V_N$	$V_N$	$V_W$	$H_W$		$V_C$	$H_C$	
		STATIC	STEADY BRAKING*	STATIC	STEADY BRAKING*	INST BRAKING**	STATIC	STEADY BRAKING*	INST BRAKING**
LB	628,000	62,500	99,100	242,000	79,700	168,200	104,800	34,500	72,900
kg	284,900	28,300	45,000	109,800	36,200	76,300	47,600	15,600	33,100

\* AIRCRAFT DECELERATION = 10 FT/SEC<sup>2</sup>.  $H_W$  AND  $H_C$  ASSUME DECELERATION FROM BRAKING ONLY  
 \*\* INSTANTANEOUS BRAKING; COEFFICIENT OF FRICTION = 0.8

DMC005-77

### 7.3 MAXIMUM PAVEMENT LOADS MODEL MD-11

REV D

## **7.4 Landing Gear Loading on Pavement**

### **7.4.1 Loads on the Main Landing Gear Group**

For the MD-11, the main gear group consists of two wing gears plus one center gear.

In the example for the MD-11, the gross weight is 470,000 pounds, the percent of weight on the main gears is 93.77 percent, and the total weight on the three main gears is 440,730 pounds.

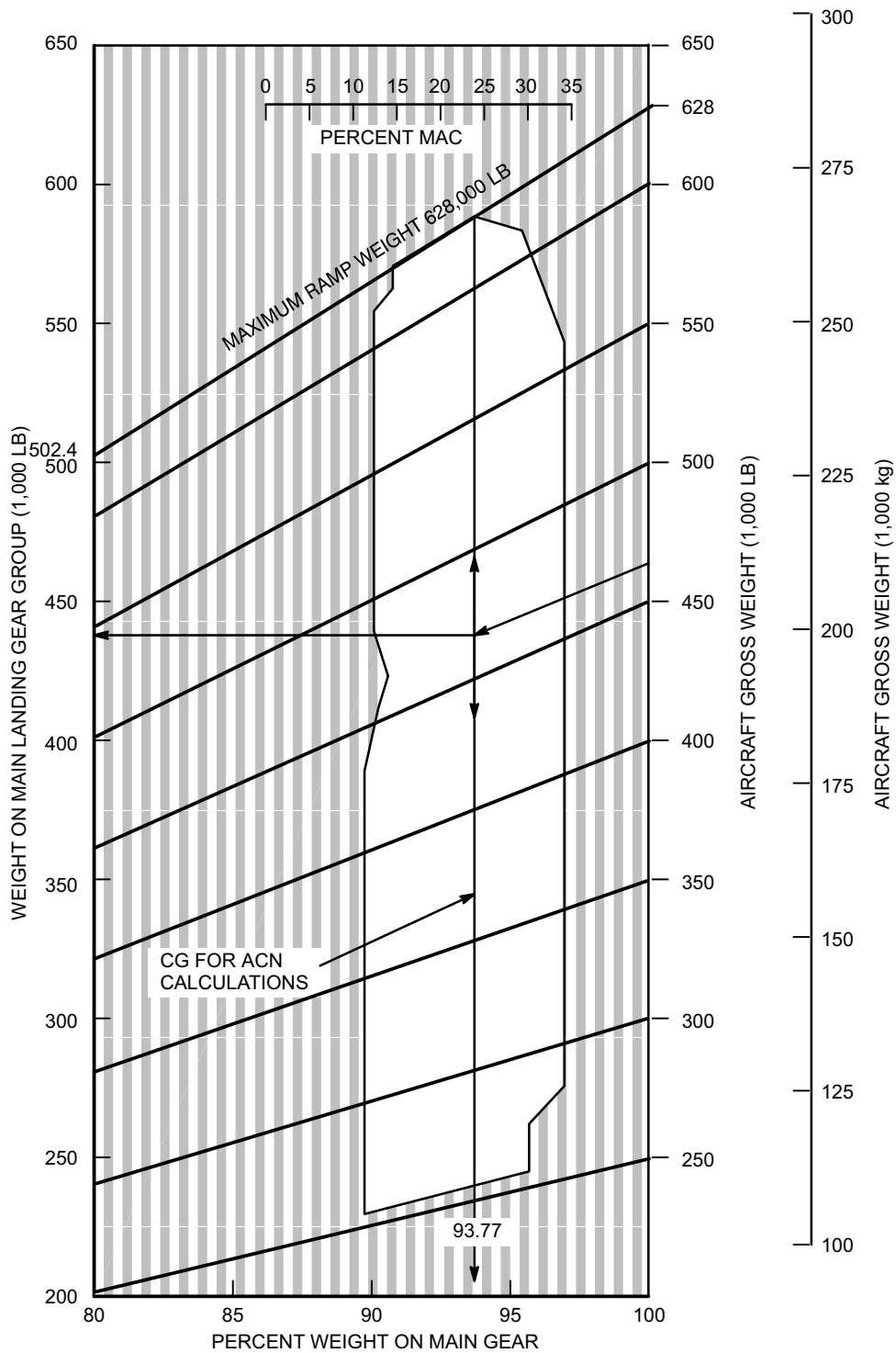

DMC005-66

### 7.4 LANDING GEAR LOADING ON PAVEMENT MODEL MD-11

REV D



NOTE: H54 x 21.0-24 TIRES TIRE PRESSURE CONSTANT AT 205 PSI (14.4 kg/cm<sup>2</sup>)

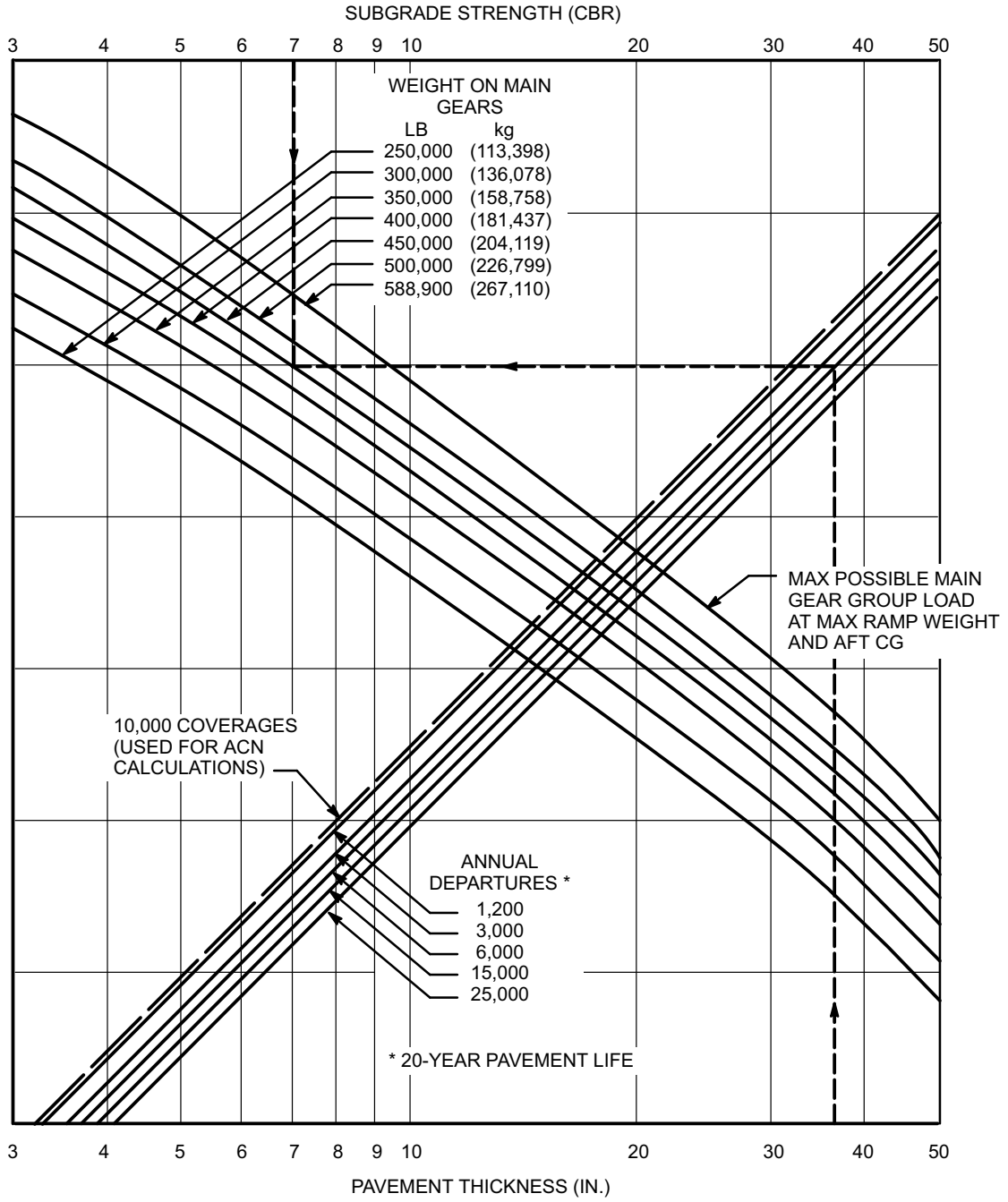

DMC005-67

**7.5 FLEXIBLE PAVEMENT REQUIREMENTS  
U.S. ARMY CORPS OF ENGINEERS/FAA DESIGN METHOD  
MODEL MD-11**

REV D

## **7.6 Flexible Pavement Requirements, LCN Conversion**

To determine the airplane weight that can be accommodated on a particular flexible airport pavement, both the LCN of the pavement and the thickness (h) of the pavement must be known.

In the example for the MD-11, the flexible pavement thickness is 30 inches, the LCN is 76, and the main landing gear group weight is 350,000 pounds.

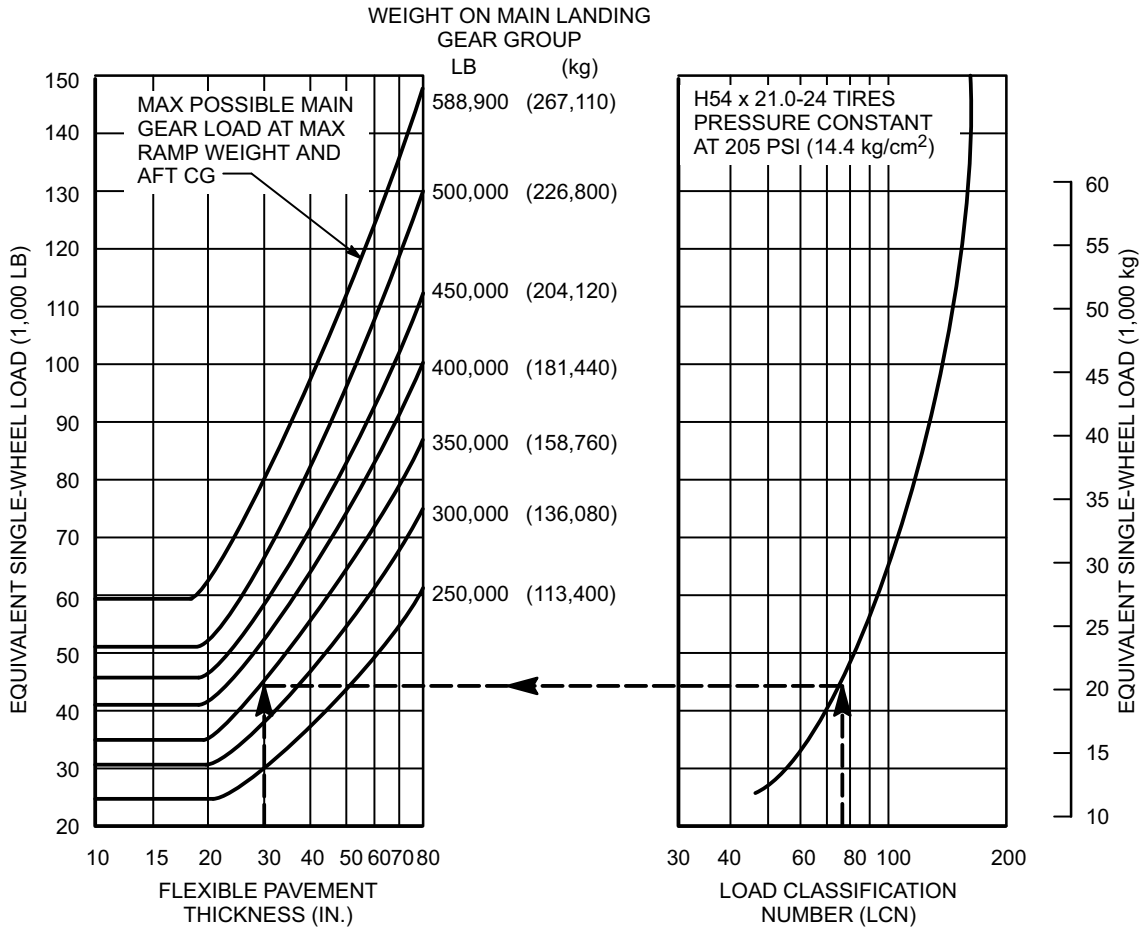

NOTE: EQUIVALENT SINGLE-WHEEL LOADS ARE DERIVED BY METHODS SHOWN IN ICAO AERODROME MANUAL, PART 2, PAR. 4.1.3

DMC005-68

## 7.6 FLEXIBLE PAVEMENT REQUIREMENTS – LCN CONVERSION MODEL MD-11

REV D

## **7.7 Rigid Pavement Requirements, Portland Cement Association Design Method**

To determine the airplane weight that can be accommodated on a particular rigid pavement, the thickness of the pavement, the subgrade modulus ( $k$ ), and the allowable working stress must be known.

In the example for the MD-11, the rigid pavement thickness is 13.7 inches, the subgrade modulus is 150, and the allowable working stress is 400 psi. For these conditions, the weight on the landing gear group is 450,000 pounds.

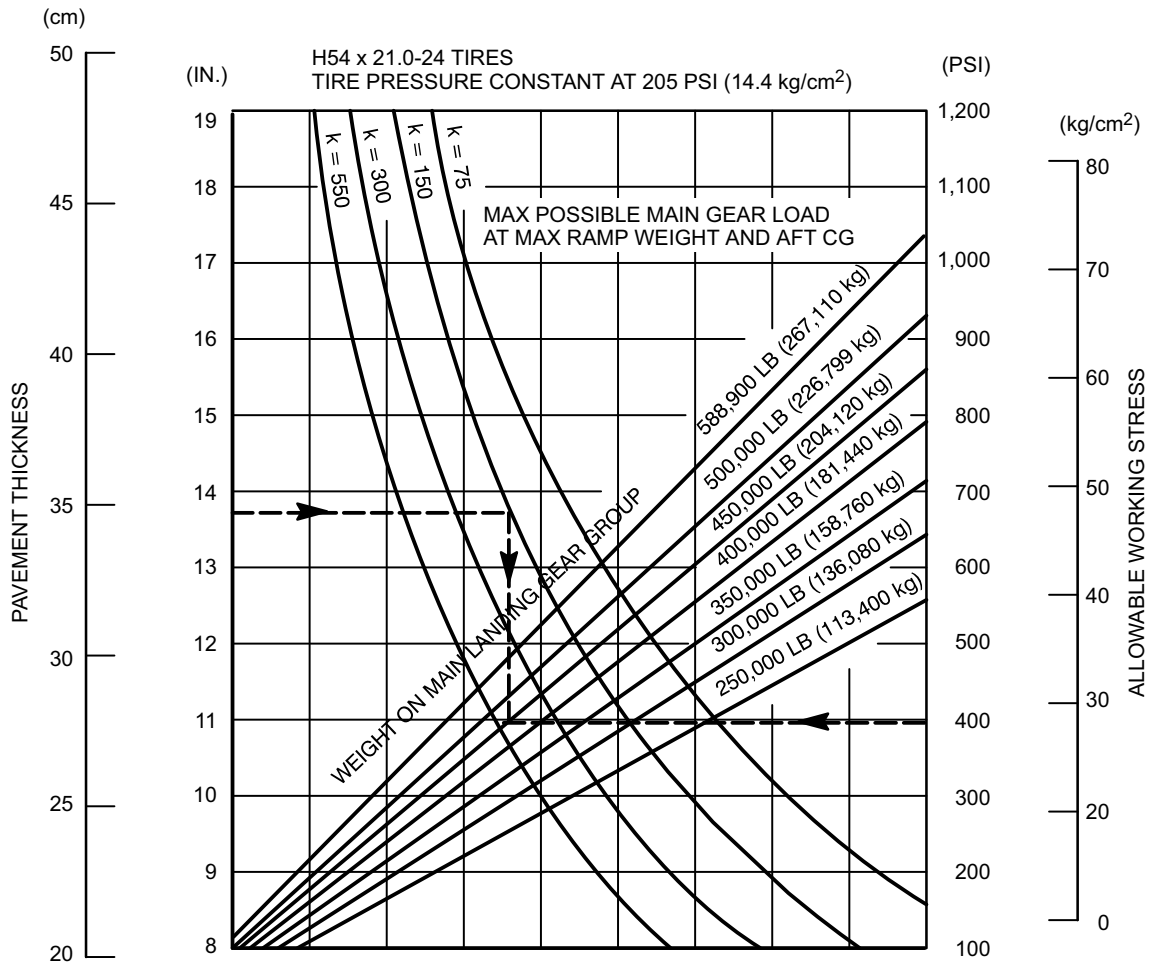

NOTE: THE VALUES OBTAINED BY USING THE MAX LOAD REFERENCE LINE AND ANY VALUES OF K ARE EXACT. FOR LOADS LESS THAN MAX, THE CURVES ARE EXACT FOR K = 300, BUT DEVIATE SLIGHTLY FOR OTHER VALUES OF K.

REF: DESIGN OF CONCRETE AIRPORT PAVEMENT, 1968 PORTLAND CEMENT ASSOCIATION COMPUTER PROGRAM

DMC005-69

**7.7 RIGID PAVEMENT REQUIREMENTS,  
PORTLAND CEMENT ASSOCIATION DESIGN METHOD  
MODEL MD-11**

REV D

## 7.8 Rigid Pavement Requirements, LCN Conversion

To determine the airplane weight that can be accommodated on a particular rigid airport pavement, both the LCN of the pavement and the radius of relative stiffness must be known.

In the example for the MD-11, the rigid pavement radius of relative stiffness is 40 inches and the LCN is 78. For these conditions, the weight on the main landing gear group is 400,000 pounds.

The LCN charts use  $\ell$ -values based on Young's Modulus (E) of 4 million psi and Poisson's ratio (m) of 0.15. For convenience in finding  $\ell$ -values based on other values of E and m, the curves in chart 7.8.2 are included. For example, to find an  $\ell$ -value based on an E of 3 million psi, the E-factor of 0.931 is multiplied by the  $\ell$ -value found in Chart 7.8.1. The effect of variations in m on the  $\ell$ -value is treated in a similar manner.

Note: If the resulting aircraft LCN is not more than 10 percent above the published pavement LCN, the United Kingdom, which originated the LCN method, considers that the bearing strength of the pavement is sufficient for unlimited use by the airplane. The figure of 10 percent has been chosen as representing the lowest degree of variation in LCN which is significant. (Reference: ICAO Aerodrome Design Manual, Part 3 — Pavements, Document 9157-AN/901, 1977 Edition.)

H54 x 21.0-24 TIRES  
TIRE PRESSURE CONSTANT AT 205 PSI (14.4 kg/cm<sup>2</sup>)

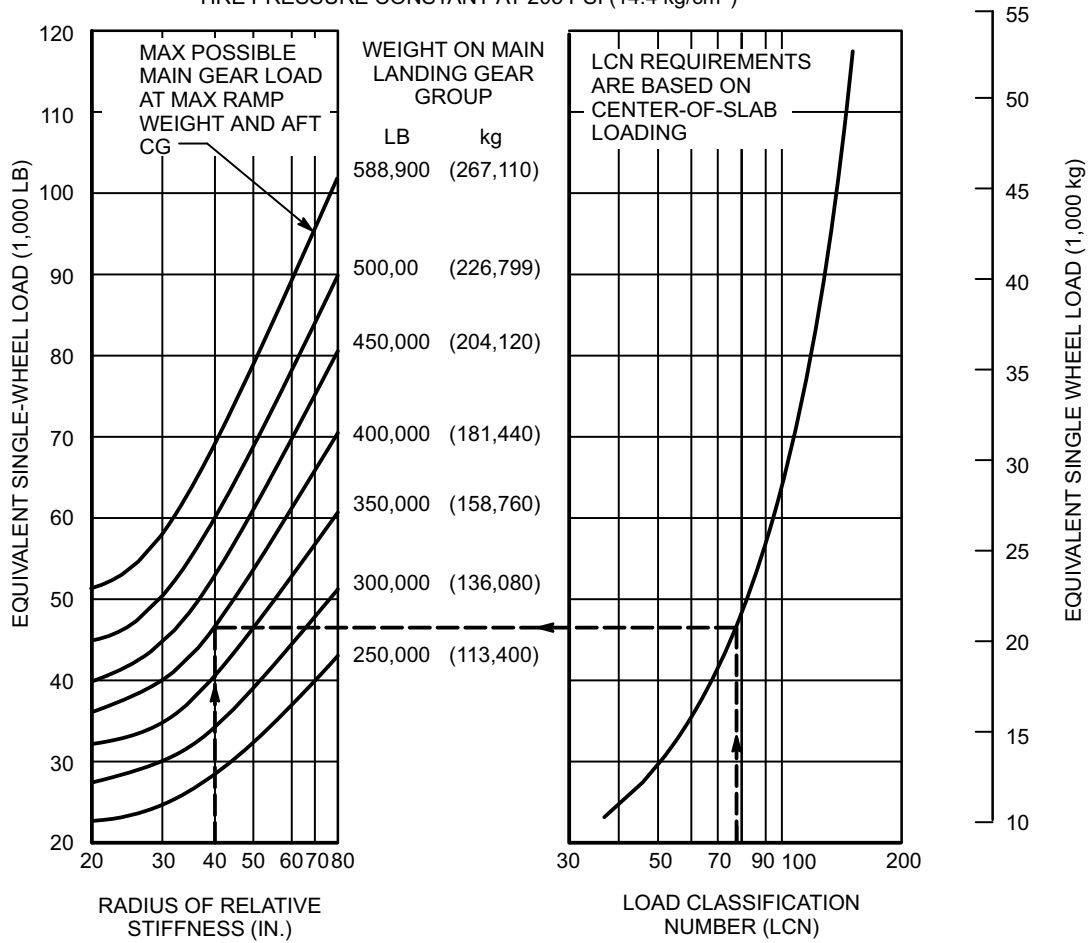

NOTE: EQUIVALENT SINGLE-WHEEL LOADS ARE DERIVED BY METHODS SHOWN IN ICAO AERODROME MANUAL, PART 2, PAR. 4.1.3

DMC005-70

### 7.8.1 RIGID PAVEMENT REQUIREMENTS, LCN CONVERSION MODEL MD-11

REV D

RADIUS OF RELATIVE STIFFNESS ( $\ell$ )  
VALUES IN INCHES

$$\ell = \sqrt[4]{\frac{Ed^3}{12(1-\mu^2)k}} = 24.1652 \sqrt[4]{\frac{d^3}{k}}$$

WHERE: E = YOUNG'S MODULUS =  $4 \times 10^6$  PSI  
 k = SUBGRADE MODULUS, LB/IN.<sup>3</sup>  
 d = RIGID-PAVEMENT THICKNESS, IN.  
 $\mu$  = POISSON'S RATIO = 0.15

d (IN.)	k = 75	k = 100	k = 150	k = 200	k = 250	k = 300	k = 350	k = 400	k = 500	k = 550
6.0	31.48	29.30	26.47	24.63	23.30	22.26	21.42	20.72	19.59	19.13
6.5	33.43	31.11	28.11	26.16	24.74	23.64	22.74	22.00	20.80	20.31
7.0	35.34	32.89	29.72	27.65	26.15	24.99	24.04	23.25	21.99	21.47
7.5	37.22	34.63	31.29	29.12	27.54	26.32	25.32	24.49	23.16	22.61
8.0	39.06	36.35	32.85	30.57	28.91	27.62	26.58	25.70	24.31	23.74
8.5	40.88	38.04	34.37	31.99	30.25	28.91	27.81	26.90	25.44	24.84
9.0	42.67	39.71	35.88	33.39	31.58	30.17	29.03	28.08	26.55	25.93
9.5	44.43	41.35	37.36	34.77	32.89	31.42	30.23	29.24	27.65	27.00
10.0	46.18	42.97	38.83	36.14	34.17	32.65	31.42	30.39	28.74	28.06
10.5	47.90	44.57	40.28	37.48	35.45	33.87	32.59	31.52	29.81	29.11
11.0	49.60	46.16	41.71	38.81	36.71	35.07	33.75	32.64	30.87	30.14
11.5	51.28	47.72	43.12	40.13	37.95	36.26	34.89	33.74	31.91	31.16
12.0	52.94	49.27	44.52	41.43	39.18	37.44	36.02	34.84	32.95	32.17
12.5	54.59	50.80	45.90	42.72	40.40	38.60	37.14	35.92	33.97	33.17
13.0	56.22	52.32	47.27	43.99	41.61	39.75	38.25	36.99	34.99	34.16
13.5	57.83	53.82	48.63	45.26	42.80	40.89	39.35	38.06	35.99	35.14
14.0	59.43	55.31	49.98	46.51	43.98	42.02	40.44	39.11	36.99	36.12
14.5	61.02	56.78	51.31	47.75	45.16	43.15	41.51	40.15	37.97	37.08
15.0	62.59	58.25	52.63	48.98	46.32	44.26	42.58	41.19	38.95	38.03
15.5	64.15	59.70	53.94	50.20	47.47	45.36	43.64	42.21	39.92	38.98
16.0	65.69	61.13	55.24	51.41	48.62	46.45	44.70	43.23	40.88	39.92
16.5	67.23	62.56	56.53	52.61	49.75	47.54	45.74	44.24	41.84	40.85
17.0	68.75	63.98	57.81	53.80	50.88	48.61	46.77	45.24	42.78	41.78
17.5	70.26	65.38	59.48	54.98	52.00	49.68	47.80	46.23	43.72	42.70
18.0	71.76	66.78	60.35	56.16	53.11	50.74	48.82	47.22	44.66	43.61
19.0	74.73	69.54	62.84	58.48	55.31	52.84	50.84	49.17	46.51	45.41
20.0	77.66	72.27	65.30	60.77	57.47	54.92	52.84	51.10	48.33	47.19
21.0	80.55	74.97	67.74	63.04	59.62	56.96	54.81	53.01	50.13	48.95
22.0	83.41	77.63	70.14	65.28	61.73	58.98	56.75	54.89	51.91	50.69
23.0	86.24	80.26	72.52	67.49	63.83	60.98	58.68	56.75	53.67	52.41
24.0	89.04	82.86	74.87	69.68	65.90	62.96	60.58	58.89	55.41	54.11
25.0	91.81	85.44	77.20	71.84	67.95	64.92	62.46	60.41	57.14	55.79

REFERENCE: PORTLAND CEMENT ASSOCIATION

DMC005-71

## 7.8.2 RADIUS OF RELATIVE STIFFNESS



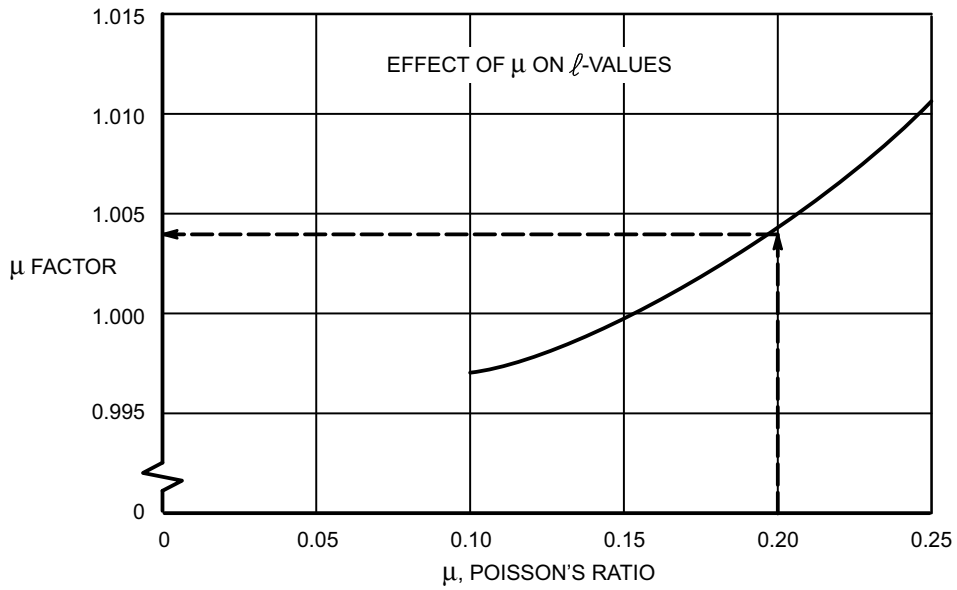
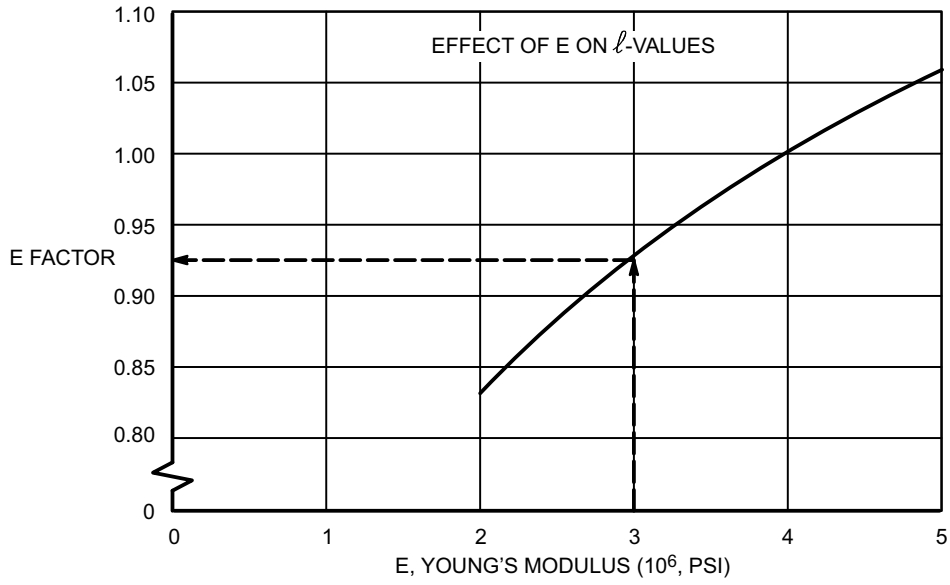

NOTE: BOTH CURVES ON THIS PAGE ARE USED TO ADJUST THE  $l$ -VALUES OF TABLE 7.8.2

### 7.8.3 EFFECT OF E AND $\mu$ ON $l$ -VALUES

DMC005-72

## **7.9 ACN-PCN Reporting System: Flexible and Rigid Pavements**

To determine the ACN of an aircraft on flexible or rigid pavement, both the aircraft gross weight and the subgrade strength category must be known. The examples show that for an aircraft gross weight of 425,000 pounds and low subgrade strength, the ACN for flexible pavement is 50 and the ACN for rigid pavement for the same gross weight is 48.

Note: An aircraft with an ACN equal to or less than the reported PCN can operate on the pavement subject to any limitations on the tire pressure.

### 7.9.1 Development of ACN Charts

The ACN charts for flexible and rigid pavements were developed by methods referenced in the ICAO Aerodrome Manual, Part 3 — Pavements, Document 9157-AN/901, 1983 Edition. The procedures used in developing these charts are described below.

The following procedure was used to develop the flexible-pavement ACN charts already shown in this subsection.

1. Determine the percentage of weight on the main gear to be used below in Steps 2, 3, and 4, below. The maximum aft center-of-gravity position yields the critical loading on the critical gear (see Subsection 7.4). This center-of-gravity position is used to determine main gear loads at all gross weights of the model being considered.
2. Establish a flexible-pavement requirements chart using the S-77-1 design method, such as shown on the right side of Figure 7.9.3. Use standard subgrade strengths of CBR 3, 6, 10, and 15 percent and 10,000 coverages. This chart provides the same thickness values as those of Subsection 7.5, but is presented here in a different format.
3. Determine reference thickness values from the pavement requirements chart of Step 2 for each standard subgrade strength and gear loading.
4. Enter the reference thickness values into the ACN flexible-pavement conversion chart shown on the left side of Figure 7.9.3 to determine ACN. This chart was developed using the S-77-1 design method with a single tire inflated to 1.25 MPa (181 psi) pressure and 10,000 coverages. The ACN is two times the derived single-wheel load expressed in thousands of kilograms. These values of ACN were plotted as functions of aircraft gross weight, as already shown.

The following procedure was used to develop the rigid-pavement ACN charts already shown in this subsection.

1. Determine the percentage of weight on the main gear to be used in Steps 2, 3, and 4, below. The maximum aft center-of-gravity position yields the critical loading on the critical gear (see Subsection 7.4). This center-of-gravity position is used to determine main gear loads at all gross weights of the model being considered.
2. Establish a rigid-pavement requirements chart using the PCA computer program PDILB, such as shown on the right side of Figure 7.9.4. Use standard subgrade strengths of  $k = 75, 150, 300, \text{ and } 550 \text{ lb/in.}^3$  (nominal values for  $k = 20, 40, 80, \text{ and } 150 \text{ MN/m}^3$ ). This chart provides the same thickness values as those of Subsection 7.7.
3. Determine reference thickness values from the pavement requirements chart of Step 2 for each standard subgrade strength and gear loading at 400 psi working stress (nominal value for 2.75 MPa working stress).

4. Enter the reference thickness values into the ACN rigid-pavement conversion chart shown on the left side of Figure 7.9.4 to determine ACN. This chart was developed using the PCA computer program PDILB with a single tire inflated to 1.25 MPa (181 psi) pressure and a working stress of 2.75 MPa (400 psi.) The ACN is two times the derived single-wheel load expressed in thousands of kilograms. These values of ACN were plotted as functions of aircraft gross weight, as already shown in this subsection.

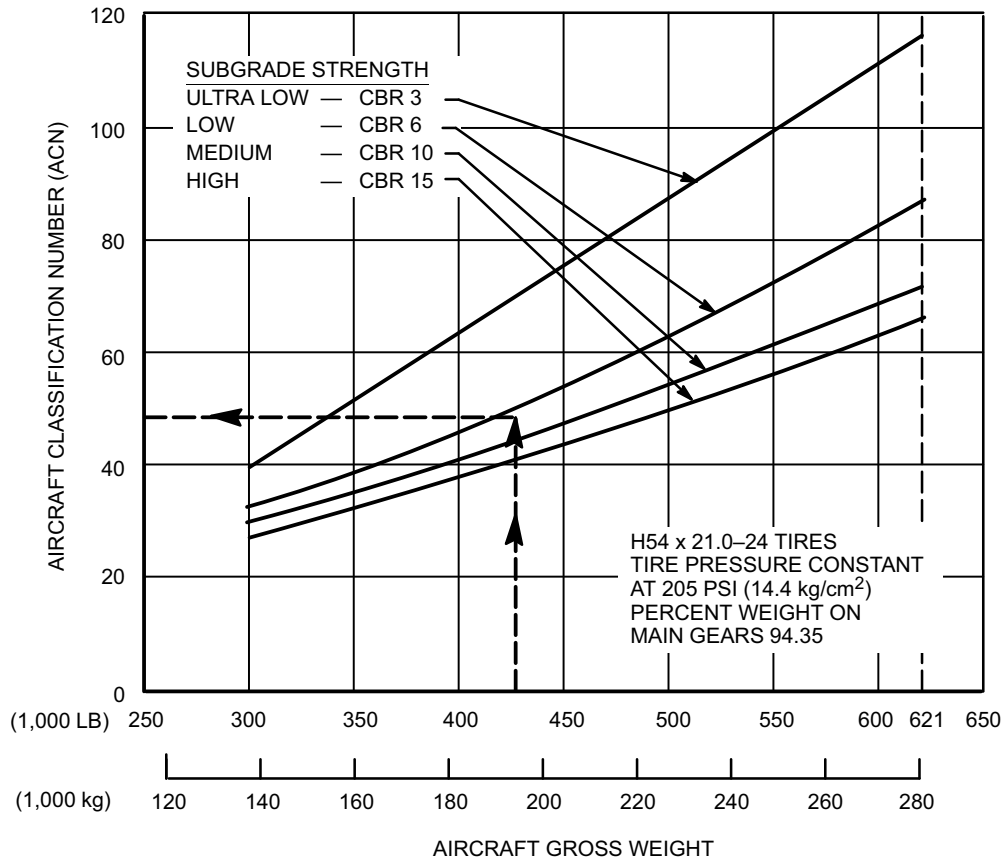

DMC005-73

### 7.9.1 AIRCRAFT CLASSIFICATION NUMBER – FLEXIBLE PAVEMENT MODEL MD-11

REV B

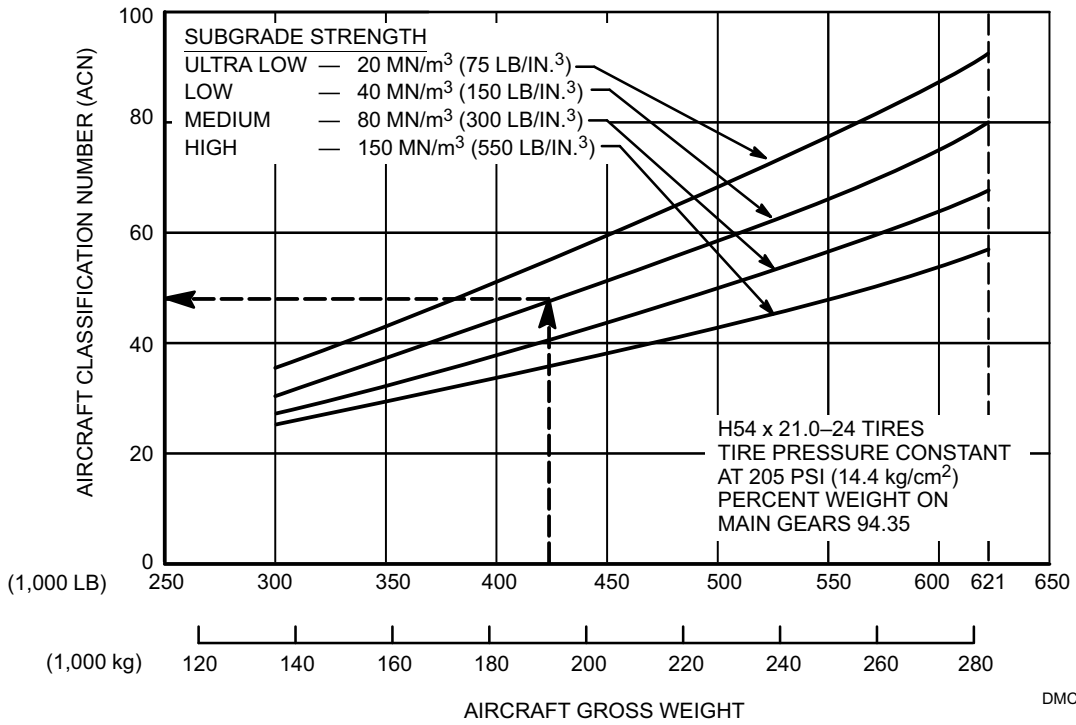

DMC005-74

### 7.9.2 AIRCRAFT CLASSIFICATION NUMBER – RIGID PAVEMENT MODEL MD-11

REV B

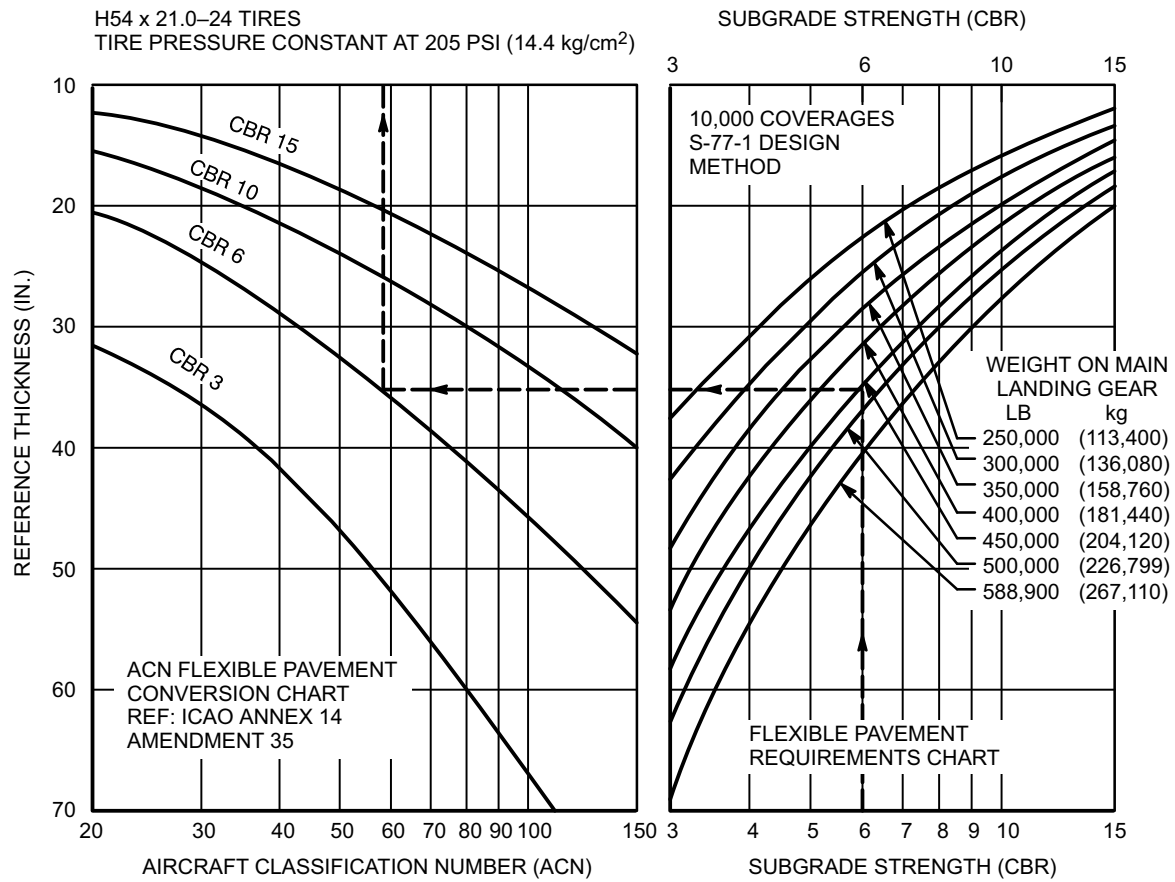

DMC005-75

### 7.9.3 DEVELOPMENT OF AIRCRAFT CLASSIFICATION NUMBER (ACN) – FLEXIBLE PAVEMENT MODEL MD-11

REV D

H54 x 21.0-24 TIRES  
 TIRE PRESSURE CONSTANT AT 205 PSI (14.4 kg/cm<sup>2</sup>)

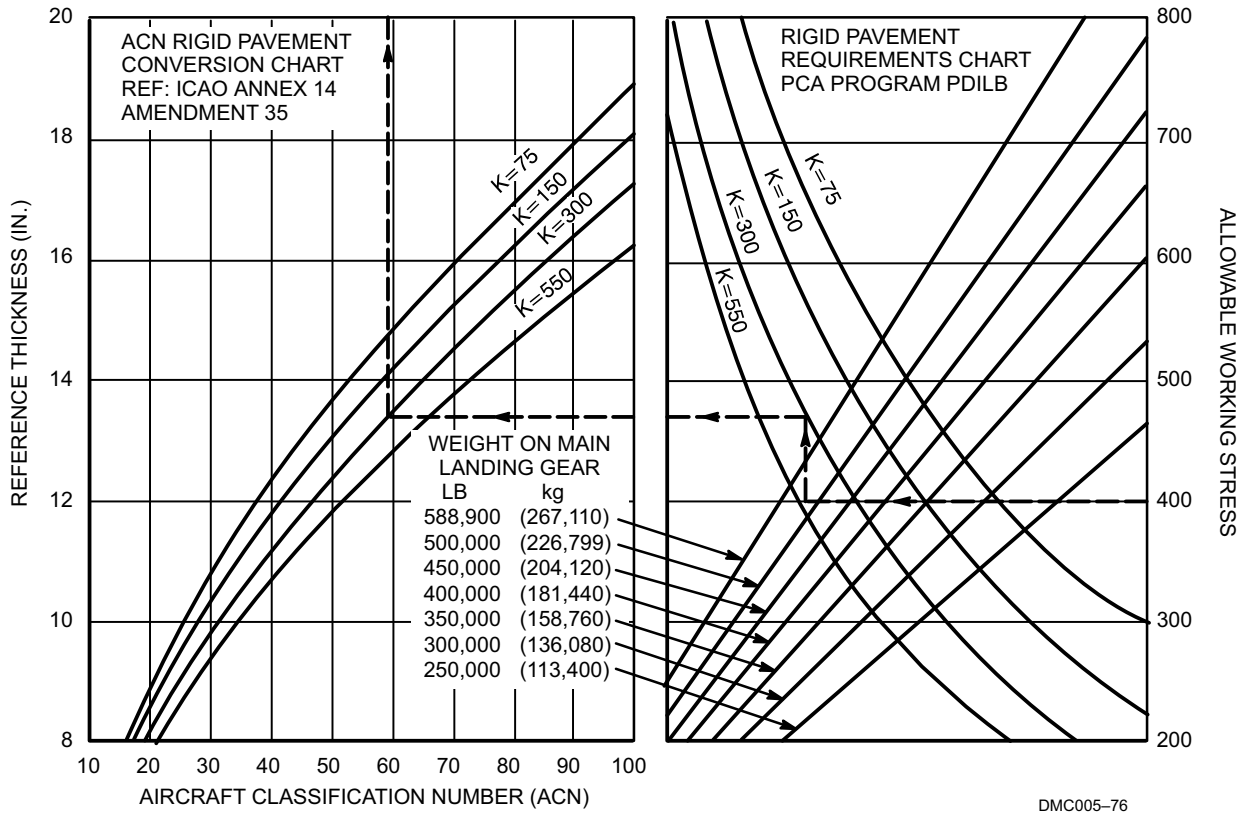

**7.9.4 DEVELOPMENT OF AIRCRAFT CLASSIFICATION NUMBER (ACN) – RIGID PAVEMENT MODEL MD-11**

REV D



## **8.0 POSSIBLE MD-11 DERIVATIVE AIRPLANES**

## **8.0 POSSIBLE MD-11 DERIVATIVE AIRPLANES**

An MD-11 growth version may be expected with a gross weight of up to about 800,000 pounds (298,400 kg), a wingspan of up to 211 feet (64.3 m), and an overall length of 230 (70.1 m) to 260 (79.2 m) feet.

## **9.0 MD-11 SCALE DRAWINGS**

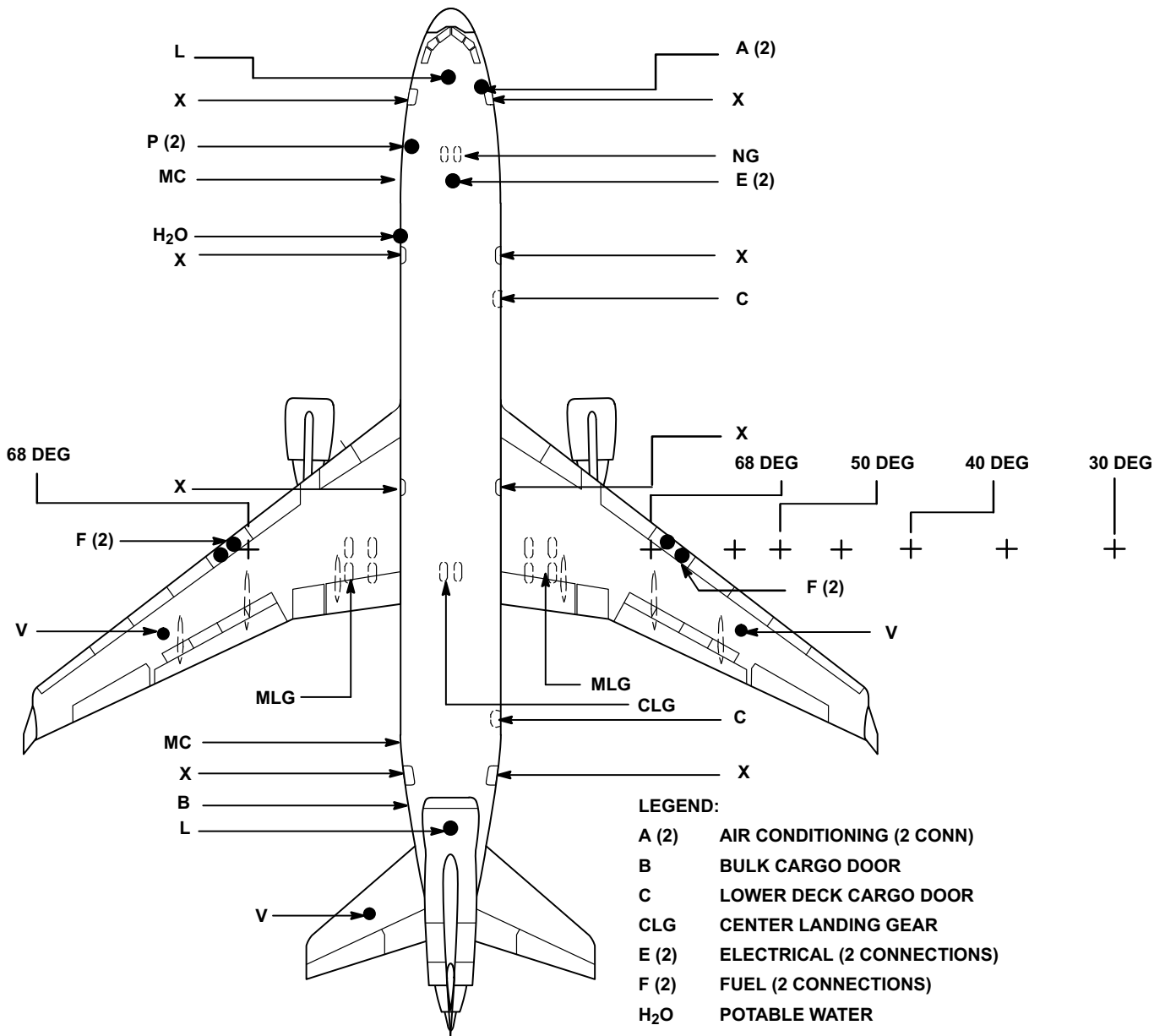

- LEGEND:**
- A (2) AIR CONDITIONING (2 CONN)
  - B BULK CARGO DOOR
  - C LOWER DECK CARGO DOOR
  - CLG CENTER LANDING GEAR
  - E (2) ELECTRICAL (2 CONNECTIONS)
  - F (2) FUEL (2 CONNECTIONS)
  - H<sub>2</sub>O POTABLE WATER
  - L LAVATORY
  - MC MAIN DECK CARGO DOOR
  - MLG MAIN LANDING GEAR
  - NG NOSE GEAR
  - P (2) PNEUMATIC (2 CONNECTIONS)
  - V FUEL VENT
  - X PASSENGER DOOR
  - + TURNING RADIUS POINTS:  
68 DEG, 60 DEG, 55 DEG, 50 DEG,  
45 DEG, 40 DEG, 35 DEG, 30 DEG

**9.0 SCALE DRAWINGS**  
**9.1 1 INCH EQUALS 32 FEET**  
**MODEL MD-11**

DMC005-81

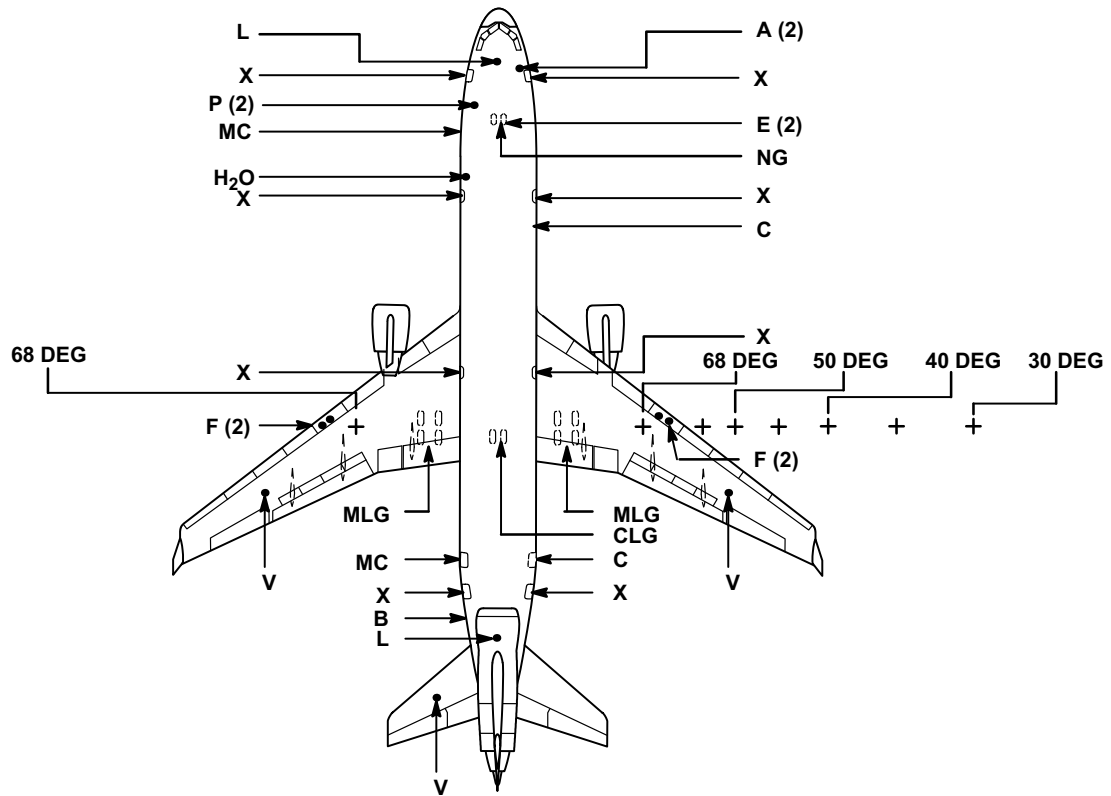

**LEGEND:**

- A (2) AIR CONDITIONING (2 CONN)
- B BULK CARGO DOOR
- C LOWER DECK CARGO DOOR
- CLG CENTER LANDING GEAR
- E (2) ELECTRICAL (2 CONNECTIONS)
- F (2) FUEL (2 CONNECTIONS)
- H<sub>2</sub>O POTABLE WATER
- L LAVATORY

- MC MAIN DECK CARGO DOOR
- MLG MAIN LANDING GEAR
- NG NOSE GEAR
- P (2) PNEUMATIC (2 CONNECTIONS)
- V FUEL VENT
- X PASSENGER DOOR
- + TURNING RADIUS POINTS:  
68 DEG, 60 DEG, 55 DEG, 50 DEG,  
45 DEG, 40 DEG, 35 DEG, 30 DEG

**9.0 SCALE DRAWINGS  
9.2 1 INCH EQUALS 50 FEET  
MODEL MD-11**

DMC005-84

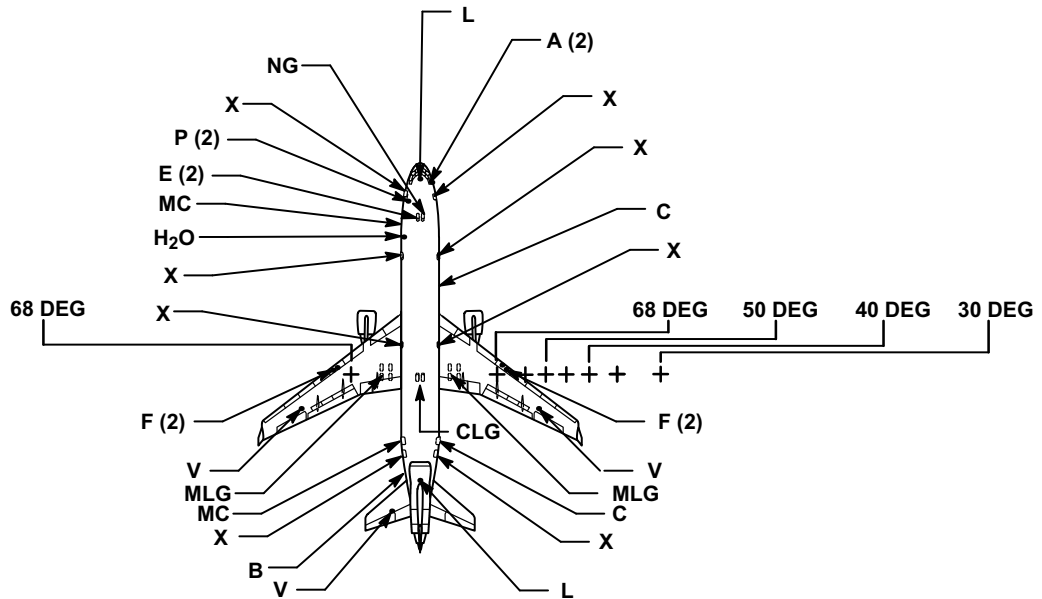

**LEGEND:**

- |                  |                            |       |                                 |
|------------------|----------------------------|-------|---------------------------------|
| A (2)            | AIR CONDITIONING (2 CONN)  | MC    | MAIN DECK CARGO DOOR            |
| B                | BULK CARGO DOOR            | MLG   | MAIN LANDING GEAR               |
| C                | LOWER DECK CARGO DOOR      | NG    | NOSE GEAR                       |
| CLG              | CENTER LANDING GEAR        | P (2) | PNEUMATIC (2 CONNECTIONS)       |
| E (2)            | ELECTRICAL (2 CONNECTIONS) | V     | FUEL VENT                       |
| F (2)            | FUEL (2 CONNECTIONS)       | X     | PASSENGER DOOR                  |
| H <sub>2</sub> O | POTABLE WATER              | +     | TURNING RADIUS POINTS:          |
| L                | LAVATORY                   |       | 68 DEG, 60 DEG, 55 DEG, 50 DEG, |
|                  |                            |       | 45 DEG, 40 DEG, 35 DEG, 30 DEG  |

**9.0 SCALE DRAWINGS  
9.3 1 INCH EQUALS 100 FEET  
MODEL MD-11**

DMC005-85

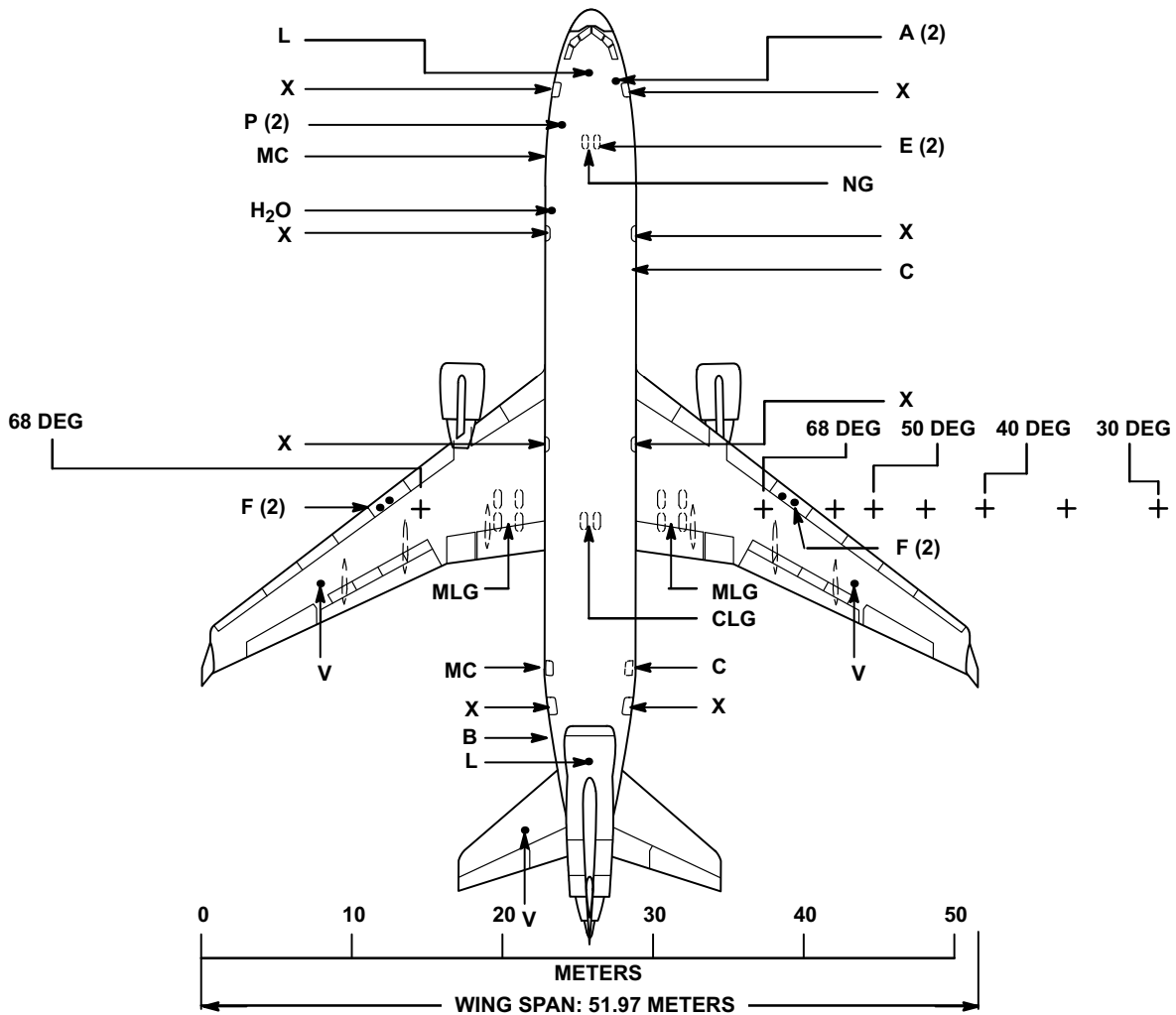

**LEGEND:**

- |                  |                            |       |   |
|------------------|----------------------------|-------|---|
| A (2)            | AIR CONDITIONING (2 CONN)  | MC    | MAIN DECK CARGO DOOR  |
| B                | BULK CARGO DOOR            | MLG   | MAIN LANDING GEAR   |
| C                | LOWER DECK CARGO DOOR      | NG    | NOSE GEAR   |
| CLG              | CENTER LANDING GEAR        | P (2) | PNEUMATIC (2 CONNECTIONS)   |
| E (2)            | ELECTRICAL (2 CONNECTIONS) | V     | FUEL VENT   |
| F (2)            | FUEL (2 CONNECTIONS)       | X     | PASSENGER DOOR  |
| H <sub>2</sub> O | POTABLE WATER              | +     | TURNING RADIUS POINTS:<br>68 DEG, 60 DEG, 55 DEG, 50 DEG,<br>45 DEG, 40 DEG, 35 DEG, 30 DEG |
| L                | LAVATORY                   |       |   |

**9.0 SCALE DRAWINGS  
9.4 1 TO 500  
MODEL MD-11**

DMC005-86

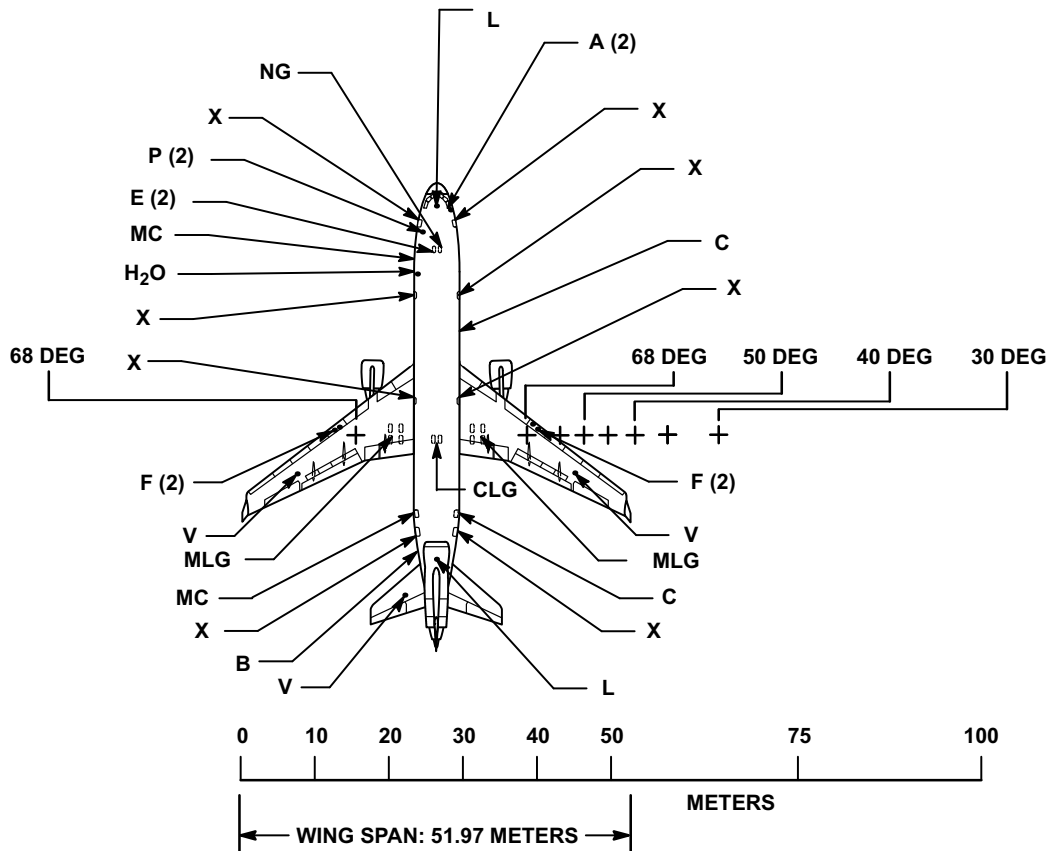

**LEGEND:**

- |                  |                            |       |   |
|------------------|----------------------------|-------|---|
| A (2)            | AIR CONDITIONING (2 CONN)  | MC    | MAIN DECK CARGO DOOR  |
| B                | BULK CARGO DOOR            | MLG   | MAIN LANDING GEAR   |
| C                | LOWER DECK CARGO DOOR      | NG    | NOSE GEAR   |
| CLG              | CENTER LANDING GEAR        | P (2) | PNEUMATIC (2 CONNECTIONS)   |
| E (2)            | ELECTRICAL (2 CONNECTIONS) | V     | FUEL VENT   |
| F (2)            | FUEL (2 CONNECTIONS)       | X     | PASSENGER DOOR  |
| H <sub>2</sub> O | POTABLE WATER              | +     | TURNING RADIUS POINTS:<br>68 DEG, 60 DEG, 55 DEG, 50 DEG,<br>45 DEG, 40 DEG, 35 DEG, 30 DEG |
| L                | LAVATORY                   |       |   |

**9.0 SCALE DRAWINGS  
9.5 1 TO 1,000  
MODEL MD-11**

DMC005-87