

International Standards  
and Recommended Practices



**Annex 10**  
to the Convention on  
International Civil Aviation

# Aeronautical Telecommunications

---

**Volume IV**  
Surveillance and Collision Avoidance Systems

This edition incorporates all amendments adopted by the Council prior to 27 February 2007 and supersedes, on 22 November 2007, all previous editions of Annex 10, Volume IV.

For information regarding the applicability of the Standards and Recommended Practices, see Foreword.

Fourth Edition  
July 2007

International Civil Aviation Organization





## TRANSMITTAL NOTE

### NEW EDITIONS OF ANNEXES TO THE CONVENTION ON INTERNATIONAL CIVIL AVIATION

It has come to our attention that when a new edition of an Annex is published, users have been discarding, along with the previous edition of the Annex, the **Supplement** to the previous edition. Please note that the Supplement to the previous edition should be retained until a new Supplement is issued.

---



**International Standards  
and Recommended Practices**



**Annex 10  
to the Convention on  
International Civil Aviation**

# **Aeronautical Telecommunications**

---

**Volume IV  
Surveillance and Collision Avoidance Systems**

This edition incorporates all amendments adopted by the Council prior to 27 February 2007 and supersedes, on 28 November 2007, all previous editions of Annex 10, Volume IV.

For information regarding the applicability of the Standards and Recommended Practices, see Foreword.

Fourth Edition  
July 2007

**International Civil Aviation Organization**

# AMENDMENTS

Amendments are announced in the supplements to the *Catalogue of ICAO Publications*; the Catalogue and its supplements are available on the ICAO website at [www.icao.int](http://www.icao.int). The space below is provided to keep a record of such amendments.

## RECORD OF AMENDMENTS AND CORRIGENDA

AMENDMENTS			
No.	Date applicable	Date entered	Entered by
70–82	Incorporated in this edition		
83	Did not affect this volume		
84	Did not affect this volume		
85	18/11/10		ICAO
86	Did not affect this volume		
87	Did not affect this volume		

CORRIGENDA			
No.	Date of issue	Date entered	Entered by
1	28/7/10		ICAO

# TABLE OF CONTENTS

	<i>Page</i>
<b>Foreword</b> .....	(v)
<b>Chapter 1. Definitions</b> .....	<b>1-1</b>
<b>Chapter 2. General</b> .....	<b>2-1</b>
2.1 Secondary surveillance radar (SSR) .....	2-1
2.2 Human Factors considerations.....	2-6
<b>Chapter 3. Surveillance systems</b> .....	<b>3-1</b>
3.1 Secondary surveillance radar (SSR) system characteristics.....	3-1
Appendix to Chapter 3. SSR automatic pressure-altitude transmission code (pulse position assignment).....	3-87
<b>Chapter 4. Airborne collision avoidance system</b> .....	<b>4-1</b>
4.1 Definitions relating to airborne collision avoidance system .....	4-1
4.2 ACAS I general provisions and characteristics.....	4-3
4.3 General provisions relating to ACAS II and ACAS III .....	4-5
4.4 Performance of the ACAS II collision avoidance logic.....	4-30A
4.5 ACAS use of extended squitter.....	4-45
<b>Chapter 5. Mode S extended squitter</b> .....	<b>5-1</b>
5.1 Mode S extended squitter transmitting system characteristics .....	5-1
5.2 Mode S extended squitter receiving system characteristics (ADS-B in and TIS-B in).....	5-2
<b>Chapter 6. Multilateration systems</b> .....	<b>6-1</b>
6.1 Definitions .....	6-1
6.2 Functional requirements .....	6-1
6.3 Protection of the radio frequency environment.....	6-2
6.4 Performance requirements .....	6-2
<b>Chapter 7. Technical requirements for airborne surveillance applications</b> .....	<b>7-1</b>
7.1 General requirements.....	7-1

Page

<b>Attachment. Guidance material related to airborne collision avoidance system (ACAS).....</b>	<b>ATT-1</b>
1. Equipment, functions and capabilities .....	ATT-1
2. Factors affecting system performance .....	ATT-5
3. Considerations on technical implementation .....	ATT-7
4. Typical algorithms and parameters for threat detection and generation of advisories.....	ATT-37
5. ACAS II use of hybrid surveillance techniques.....	ATT-54
6. Performance of the collision avoidance logic .....	ATT-56

---



# FOREWORD

## Historical background

Standards and Recommended Practices for Aeronautical Telecommunications were first adopted by the Council on 30 May 1949 pursuant to the provisions of Article 37 of the Convention on International Civil Aviation (Chicago 1944) and designated as Annex 10 to the Convention. They became effective on 1 March 1950. The Standards and Recommended Practices were based on recommendations of the Communications Division at its Third Session in January 1949.

Up to and including the Seventh Edition, Annex 10 was published in one volume containing four Parts together with associated attachments: Part I — Equipment and Systems, Part II — Radio Frequencies, Part III — Procedures, and Part IV — Codes and Abbreviations.

By Amendment 42, Part IV was deleted from the Annex; the codes and abbreviations contained in that Part were transferred to a new document, Doc 8400.

As a result of the adoption of Amendment 44 on 31 May 1965, the Seventh Edition of Annex 10 was replaced by two volumes: Volume I (First Edition) containing Part I — Equipment and Systems, and Part II — Radio Frequencies, and Volume II (First Edition) containing Communication Procedures.

As a result of the adoption of Amendment 70 on 20 March 1995, Annex 10 was restructured to include five volumes: Volume I — Radio Navigation Aids; Volume II — Communication Procedures; Volume III — Communication Systems; Volume IV — Surveillance Radar and Collision Avoidance Systems; and Volume V — Aeronautical Radio Frequency Spectrum Utilization. By Amendment 70, Volumes III and IV were published in 1995 and Volume V was planned for publication with Amendment 71.

Table A shows the origin of amendments to Annex 10, Volume IV subsequent to Amendment 70, together with a summary of the principal subjects involved and the dates on which the Annex and the amendments were adopted by Council, when they became effective and when they became applicable.

## Action by Contracting States

*Notification of differences.* The attention of Contracting States is drawn to the obligation imposed by Article 38 of the Convention by which Contracting States are required to notify the Organization of any differences between their national regulations and practices and the International Standards contained in this Annex and any amendments thereto. Contracting States are invited to extend such notification to any differences from the Recommended Practices contained in this Annex and any amendments thereto, when the notification of such differences is important for the safety of air navigation. Further, Contracting States are invited to keep the Organization currently informed of any differences which may subsequently occur, or of the withdrawal of any differences previously notified. A specific request for notification of differences will be sent to Contracting States immediately after the adoption of each amendment to this Annex.

The attention of States is also drawn to the provisions of Annex 15 related to the publication of differences between their national regulations and practices and the related ICAO Standards and Recommended Practices through the Aeronautical Information Service, in addition to the obligation of States under Article 38 of the Convention.

*Promulgation of information.* The establishment and withdrawal of and changes to facilities, services and procedures affecting aircraft operations provided in accordance with the Standards, Recommended Practices and Procedures specified in Annex 10 should be notified and take effect in accordance with the provisions of Annex 15.

*Use of the text of the Annex in national regulations.* The Council, on 13 April 1948, adopted a resolution inviting the attention of Contracting States to the desirability of using in their own national regulations, as far as practicable, the precise language of those ICAO Standards that are of a regulatory character and also of indicating departures from the Standards, including any additional national regulations that were important for the safety or regularity of air navigation. Wherever possible, the provisions of this Annex have been deliberately written in such a way as would facilitate incorporation, without major textual changes, into national legislation.

### Status of Annex components

An Annex is made up of the following component parts, not all of which, however, are necessarily found in every Annex; they have the status indicated:

1.— *Material comprising the Annex proper:*

- a) *Standards and Recommended Practices* adopted by the Council under the provisions of the Convention. They are defined as follows:

*Standard:* Any specification for physical characteristics, configuration, matériel, performance, personnel or procedure, the uniform application of which is recognized as necessary for the safety or regularity of international air navigation and to which Contracting States will conform in accordance with the Convention; in the event of impossibility of compliance, notification to the Council is compulsory under Article 38.

*Recommended Practice:* Any specification for physical characteristics, configuration, matériel, performance, personnel or procedure, the uniform application of which is recognized as desirable in the interest of safety, regularity or efficiency of international air navigation, and to which Contracting States will endeavour to conform in accordance with the Convention.

- b) *Appendices* comprising material grouped separately for convenience but forming part of the Standards and Recommended Practices adopted by the Council.
- c) *Definitions* of terms used in the Standards and Recommended Practices which are not self-explanatory in that they do not have accepted dictionary meanings. A definition does not have independent status but is an essential part of each Standard and Recommended Practice in which the term is used, since a change in the meaning of the term would affect the specification.
- d) *Tables and Figures* which add to or illustrate a Standard or Recommended Practice and which are referred to therein, form part of the associated Standard or Recommended Practice and have the same status.

2.— *Material approved by the Council for publication in association with the Standards and Recommended Practices:*

- a) *Forewords* comprising historical and explanatory material based on the action of the Council and including an explanation of the obligations of States with regard to the application of the Standards and Recommended Practices ensuing from the Convention and the Resolution of Adoption;
- b) *Introductions* comprising explanatory material introduced at the beginning of parts, chapters or sections of the Annex to assist in the understanding of the application of the text;

- c) *Notes* included in the text, where appropriate, to give factual information or references bearing on the Standards or Recommended Practices in question, but not constituting part of the Standards or Recommended Practices;
- d) *Attachments* comprising material supplementary to the Standards and Recommended Practices, or included as a guide to their application.

### Disclaimer regarding patents

Attention is drawn to the possibility that certain elements of Standards and Recommended Practices in this Annex may be the subject of patents or other intellectual property rights. ICAO shall not be responsible or liable for not identifying any or all such rights. ICAO takes no position regarding the existence, validity, scope or applicability of any claimed patents or other intellectual property rights, and accepts no responsibility or liability therefore or relating thereto.

### Selection of language

This Annex has been adopted in four languages — English, French, Russian and Spanish. Each Contracting State is requested to select one of those texts for the purpose of national implementation and for other effects provided for in the Convention, either through direct use or through translation into its own national language, and to notify the Organization accordingly.

### Editorial practices

The following practice has been adhered to in order to indicate at a glance the status of each statement: *Standards* have been printed in light face roman; *Recommended Practices* have been printed in light face italics, the status being indicated by the prefix **Recommendation**; *Notes* have been printed in light face italics, the status being indicated by the prefix *Note*.

The following editorial practice has been followed in the writing of specifications: for Standards the operative verb “shall” is used, and for Recommended Practices the operative verb “should” is used.

The units of measurement used in this document are in accordance with the International System of Units (SI) as specified in Annex 5 to the Convention on International Civil Aviation. Where Annex 5 permits the use of non-SI alternative units these are shown in parentheses following the basic units. Where two sets of units are quoted it must not be assumed that the pairs of values are equal and interchangeable. It may, however, be inferred that an equivalent level of safety is achieved when either set of units is used exclusively.

Any reference to a portion of this document, which is identified by a number and/or title, includes all subdivisions of that portion.

Table A. Amendments to Annex 10, Volume IV

<i>Amendment</i>	<i>Source(s)</i>	<i>Subject(s)</i>	<i>Adopted/approved Effective Applicable</i>
70	Air Navigation Commission; Fifth meeting of the Secondary Surveillance Radar Improvements and Collision Avoidance Systems Panel	Creation of Volume IV and introduction of Standards and Recommended Practices and related guidance material for the airborne collision avoidance system (ACAS).	20 March 1995 24 July 1995 9 November 1995
71	Air Navigation Commission; Fourth and fifth meetings of the Secondary Surveillance Radar Improvements and Collision Avoidance Systems Panel (SICASP)	Changes to material related to SSR Mode S air-ground data link system and the carriage of SSR transponders.	12 March 1996 15 July 1996 7 November 1996
72	—	No change.	—
73 (2nd edition)	Air Navigation Commission; Sixth meeting of the Secondary Surveillance Radar Improvements and Collision Avoidance Systems Panel (SICASP)	Addition of specifications for the SSR Mode S system; introduction of material related to the performance of the collision avoidance logic; changes to guidance material related to the airborne collision avoidance system; introduction of Human Factors related material.	19 March 1998 20 July 1998 5 November 1998
74	Air Navigation Commission	Note related to the waiving of patent rights on Mode S extended squitter technique.	18 March 1999 18 March 1999 —
75	—	No change.	—
76	Seventh meeting of the Aeronautical Mobile Communications Panel (AMCP)	Note related to update of references to the ITU Radio Regulations.	12 March 2001 12 March 2001 —
77 (3rd edition)	Seventh meeting of the Secondary Surveillance Radar Improvements and Collision Avoidance Systems Panel (SICASP)	SSR Mode S (Chapters 2 and 3); and ACAS (Chapters 1 and 4).	27 February 2002 15 July 2002 28 November 2002
78	—	No change.	—
79	—	No change.	—
80	—	No change.	—
81	—	No change.	—
82 (4th edition)	Surveillance and Conflict Resolution Systems Panel (SCRSP)	Updates to SARPs on ADS-B	26 February 2007 16 July 2007 22 November 2007
83	—	No change.	—
84	—	No change.	—

<i>Amendment</i>	<i>Source(s)</i>	<i>Subject(s)</i>	<i>Adopted/approved Effective Applicable</i>
85	Aeronautical Surveillance Panel (ASP)	<ul style="list-style-type: none"> <li>a) Update of provisions relating to secondary surveillance radar (SSR) (Modes A/C and S) and automatic dependent surveillance — broadcast (ADS-B) using 1 090 MHz extended squitter resulting from operational experience;</li> <li>b) introduction of a system-level and functional requirement for multilateration systems used for air traffic surveillance;</li> <li>c) introduction of an initial set of technical requirements for airborne surveillance applications that are enabled by the use of ADS-B IN messages on the flight deck;</li> <li>d) new requirements for display of proximate traffic, traffic advisory (TA) and resolution advisory (RA);</li> <li>e) update of provisions on hybrid surveillance in light of relevant recent developments; and</li> <li>f) introduction of a new functional requirement for monitoring own aircraft's vertical rate during an RA which would be affected by implementing a new version of the collision avoidance system (CAS) logic (commonly referred to as traffic alert and collision avoidance system (TCAS) Version 7.1). The new version of the CAS logic would also include a change in the annunciation of the RA "Adjust Vertical Speed, Adjust" to "Level Off".</li> </ul>	<p>26 February 2010 12 July 2010 18 November 2010</p>
86	—	No change.	—
87	—	No change.	—



# INTERNATIONAL STANDARDS AND RECOMMENDED PRACTICES

## CHAPTER 1. DEFINITIONS

*Note 1.— All references to “Radio Regulations” are to the Radio Regulations published by the International Telecommunication Union (ITU). Radio Regulations are amended from time to time by the decisions embodied in the Final Acts of World Radiocommunication Conferences held normally every two to three years. Further information on the ITU processes as they relate to aeronautical radio system frequency use is contained in the Handbook on Radio Frequency Spectrum Requirements for Civil Aviation including statement of approved ICAO policies (Doc 9718).*

*Note 2.— The Mode S extended squitter system is subject to patent rights from the Massachusetts Institute of Technology (MIT) Lincoln Laboratory. On 22 August 1996, MIT Lincoln Laboratory issued a notice in the Commerce Business Daily (CBD), a United States Government publication, of its intent not to assert its rights as patent owner against any and all persons in the commercial or non-commercial practice of the patent, in order to promote the widest possible use of the Mode S extended squitter technology. Further, by letter to ICAO dated 27 August 1998, MIT Lincoln Laboratory confirmed that the CBD notice has been provided to satisfy ICAO requirements for a statement of patent rights for techniques that are included in SARPs, and that the patent holders offer this technique free of charge for any use.*

**Airborne collision avoidance system (ACAS).** An aircraft system based on secondary surveillance radar (SSR) transponder signals which operates independently of ground-based equipment to provide advice to the pilot on potential conflicting aircraft that are equipped with SSR transponders.

*Note.— SSR transponders referred to above are those operating in Mode C or Mode S.*

**Aircraft address.** A unique combination of twenty-four bits available for assignment to an aircraft for the purpose of air-ground communications, navigation and surveillance.

*Note.— SSR Mode S transponders transmit extended squitters to support the broadcast of aircraft-derived position for surveillance purposes. The broadcast of this type of information is a form of automatic dependent surveillance (ADS) known as ADS-broadcast (ADS-B).*

**Automatic dependent surveillance-broadcast (ADS-B) OUT.** A function on an aircraft or vehicle that periodically broadcasts its state vector (position and velocity) and other information derived from on-board systems in a format suitable for ADS-B IN capable receivers.

**Automatic dependent surveillance-broadcast (ADS-B) IN.** A function that receives surveillance data from ADS-B OUT data sources.

**Collision avoidance logic.** The sub-system or part of ACAS that analyses data relating to an intruder and own aircraft, decides whether or not advisories are appropriate and, if so, generates the advisories. It includes the following functions: range and altitude tracking, threat detection and RA generation. It excludes surveillance.

**Human Factors principles.** Principles which apply to design, certification, training, operations and maintenance and which seek safe interface between the human and other system components by proper consideration to human performance.

**Secondary surveillance radar (SSR).** A surveillance radar system which uses transmitters/receivers (interrogators) and transponders.

*Note.— The requirements for interrogators and transponders are specified in Chapter 3.*

**Surveillance radar.** Radar equipment used to determine the position of an aircraft in range and azimuth.

**Traffic information service – broadcast (TIS-B) IN.** A surveillance function that receives and processes surveillance data from TIS-B OUT data sources.

**Traffic information service – broadcast (TIS-B) OUT.** A function on the ground that periodically broadcasts the surveillance information made available by ground sensors in a format suitable for TIS-B IN capable receivers.

*Note.— This technique can be achieved through different data links. The requirements for Mode S extended squitters are specified in Annex 10, Volume IV, Chapter 5. The requirements for VHF digital link (VDL) Mode 4 and universal access transceiver (UAT) are specified in Annex 10, Volume III, Part I.*



## CHAPTER 2. GENERAL

### 2.1 SECONDARY SURVEILLANCE RADAR (SSR)

2.1.1 When SSR is installed and maintained in operation as an aid to air traffic services, it shall conform with the provisions of 3.1 unless otherwise specified in this 2.1.

*Note.— As referred to in this Annex, Mode A/C transponders are those which conform to the characteristics prescribed in 3.1.1. Mode S transponders are those which conform to the characteristics prescribed in 3.1.2. The functional capabilities of Mode A/C transponders are an integral part of those of Mode S transponders.*

#### 2.1.2 Interrogation modes (ground-to-air)

2.1.2.1 Interrogation for air traffic services shall be performed on the modes described in 3.1.1.4.3 or 3.1.2. The uses of each mode shall be as follows:

- 1) *Mode A* — to elicit transponder replies for identity and surveillance.
- 2) *Mode C* — to elicit transponder replies for automatic pressure-altitude transmission and surveillance.
- 3) *Intermode* —
  - a) *Mode A/C/S all-call*: to elicit replies for surveillance of Mode A/C transponders and for the acquisition of Mode S transponders.
  - b) *Mode A/C-only all-call*: to elicit replies for surveillance of Mode A/C transponders. Mode S transponders do not reply.
- 4) *Mode S* —
  - a) *Mode S-only all-call*: to elicit replies for acquisition of Mode S transponders.
  - b) *Broadcast*: to transmit information to all Mode S transponders. No replies are elicited.
  - c) *Selective*: for surveillance of, and communication with, individual Mode S transponders. For each interrogation, a reply is elicited only from the transponder uniquely addressed by the interrogation.

*Note 1.— Mode A/C transponders are suppressed by Mode S interrogations and do not reply.*

*Note 2.— There are 25 possible interrogation (uplink) formats and 25 possible Mode S reply (downlink) formats. For format assignment see 3.1.2.3.2, Figures 3-7 and 3-8.*

2.1.2.1.1 **Recommendation.**— *Administrations should coordinate with appropriate national and international authorities those implementation aspects of the SSR system which will permit its optimum use.*

*Note.*— In order to permit the efficient operation of ground equipment designed to eliminate interference from unwanted aircraft transponder replies to adjacent interrogators (defruiting equipment), States may need to develop coordinated plans for the assignment of pulse recurrence frequencies (PRF) to SSR interrogators.

2.1.2.1.2 The assignment of interrogator identifier (II) codes, where necessary in areas of overlapping coverage, across international boundaries of flight information regions, shall be the subject of regional air navigation agreements.

2.1.2.1.3 The assignment of surveillance identifier (SI) codes, where necessary in areas of overlapping coverage, shall be the subject of regional air navigation agreements.

*Note.*— The SI lockout facility cannot be used unless all Mode S transponders within coverage range are equipped for this purpose.

2.1.2.2 Mode A and Mode C interrogations shall be provided.

*Note.*— This requirement may be satisfied by intermode interrogations which elicit Mode A and Mode C replies from Mode A/C transponders.

2.1.2.3 **Recommendation.**— In areas where improved aircraft identification is necessary to enhance the effectiveness of the ATC system, SSR ground facilities having Mode S features should include aircraft identification capability.

*Note.*— Aircraft identification reporting through the Mode S data link provides unambiguous identification of aircraft suitably equipped.

#### 2.1.2.4 SIDE-LOBE SUPPRESSION CONTROL INTERROGATION

2.1.2.4.1 Side-lobe suppression shall be provided in accordance with the provisions of 3.1.1.4 and 3.1.1.5 on all Mode A, Mode C and intermode interrogations.

2.1.2.4.2 Side-lobe suppression shall be provided in accordance with the provisions of 3.1.2.1.5.2.1 on all Mode S-only all-call interrogations.

### 2.1.3 Transponder reply modes (air-to-ground)

2.1.3.1 Transponders shall respond to Mode A interrogations in accordance with the provisions of 3.1.1.7.12.1 and to Mode C interrogations in accordance with the provisions of 3.1.1.7.12.2.

*Note.*— If pressure-altitude information is not available, transponders reply to Mode C interrogations with framing pulses only.

2.1.3.1.1 The pressure-altitude reports contained in Mode S replies shall be derived as specified in 3.1.1.7.12.2.

*Note.*— 3.1.1.7.12.2 is intended to relate to Mode C replies and specifies, inter alia, that Mode C pressure-altitude reports be referenced to a standard pressure setting of 1 013.25 hectopascals. The intention of 2.1.3.1.1 is to ensure that all transponders, not just Mode C transponders, report uncorrected pressure-altitude.

2.1.3.2 Where the need for Mode C automatic pressure-altitude transmission capability within a specified airspace has been determined, transponders, when used within the airspace concerned, shall respond to Mode C interrogations with pressure-altitude encoding in the information pulses.

2.1.3.2.1 From 1 January 1999, all transponders, regardless of the airspace in which they will be used, shall respond to Mode C interrogations with pressure-altitude information.

*Note.— Operation of the airborne collision avoidance system (ACAS) depends upon intruder aircraft reporting pressure-altitude in Mode C replies.*

2.1.3.2.2 For aircraft equipped with 7.62 m (25 ft) or better pressure-altitude sources, the pressure-altitude information provided by Mode S transponders in response to selective interrogations (i.e. in the AC field, 3.1.2.6.5.4) shall be reported in 7.62 m (25 ft) increments.

*Note.— Performance of the ACAS is significantly enhanced when an intruder aircraft is reporting pressure-altitude in 7.62 m (25 ft) increments.*

2.1.3.2.3 All Mode A/C transponders shall report pressure-altitude encoded in the information pulses in Mode C replies.

2.1.3.2.4 All Mode S transponders shall report pressure-altitude encoded in the information pulses in Mode C replies and in the AC field of Mode S replies.

2.1.3.2.5 When a Mode S transponder is not receiving more pressure-altitude information from a source with a quantization of 7.62 m (25 ft) or better increments, the reported value of the altitude shall be the value obtained by expressing the measured value of the uncorrected pressure-altitude of the aircraft in 30.48 m (100 ft) increments and the Q bit (see 3.1.2.6.5.4 b)) shall be set to 0.

*Note.— This requirement relates to the installation and use of the Mode S transponder. The purpose is to ensure that altitude data obtained from a 30.48 m (100 ft) increment source are not reported using the formats intended for 7.62 m (25 ft) data.*

2.1.3.3 Transponders used within airspace where the need for Mode S airborne capability has been determined shall also respond to intermode and Mode S interrogations in accordance with the applicable provisions of 3.1.2.

2.1.3.3.1 Requirements for mandatory carriage of SSR Mode S transponders shall be on the basis of regional air navigation agreements which shall specify the airspace and the airborne implementation timescales.

2.1.3.3.2 **Recommendation.**— *The agreements indicated in 2.1.3.3.1 should provide at least five years' notice.*

#### 2.1.4 Mode A reply codes (information pulses)

2.1.4.1 All transponders shall be capable of generating 4 096 reply codes conforming to the characteristics given in 3.1.1.6.2.

2.1.4.1.1 **Recommendation.**— *ATS authorities should establish the procedures for the allotment of SSR codes in conformity with Regional Air Navigation agreements, taking into account other users of the system.*

*Note.— Principles for the allocation of SSR codes are given in Doc 4444, Chapter 8.*

2.1.4.2 The following Mode A codes shall be reserved for special purposes:

2.1.4.2.1 Code 7700 to provide recognition of an aircraft in an emergency.

2.1.4.2.2 Code 7600 to provide recognition of an aircraft with radiocommunication failure.

2.1.4.2.3 Code 7500 to provide recognition of an aircraft which is being subjected to unlawful interference.

2.1.4.3 Appropriate provisions shall be made in ground decoding equipment to ensure immediate recognition of Mode A codes 7500, 7600 and 7700.

2.1.4.4 **Recommendation.**— *Mode A code 0000 should be reserved for allocation subject to regional agreement, as a general purpose code.*

2.1.4.5 Mode A code 2000 shall be reserved to provide recognition of an aircraft which has not received any instructions from air traffic control units to operate the transponder.

### 2.1.5 Mode S airborne equipment capability

2.1.5.1 All Mode S transponders shall conform to one of the following five levels:

2.1.5.1.1 Level 1 — Level 1 transponders shall have the capabilities prescribed for:

- a) Mode A identity and Mode C pressure-altitude reporting (3.1.1);
- b) intermode and Mode S all-call transactions (3.1.2.5);
- c) addressed surveillance altitude and identity transaction (3.1.2.6.1, 3.1.2.6.3, 3.1.2.6.5 and 3.1.2.6.7);
- d) lockout protocols (3.1.2.6.9);
- e) basic data protocols except data link capability reporting (3.1.2.6.10); and
- f) air-air service and squitter transactions (3.1.2.8).

*Note.*— *Level 1 permits SSR surveillance based on pressure-altitude reporting and the Mode A identity code. In an SSR Mode S environment, technical performance relative to a Mode A/C transponder is improved due to Mode S selective aircraft interrogation.*

2.1.5.1.2 Level 2 — Level 2 transponders shall have the capabilities of 2.1.5.1.1 and also those prescribed for:

- a) standard length communications (Comm-A and Comm-B) (3.1.2.6.2, 3.1.2.6.4, 3.1.2.6.6, 3.1.2.6.8 and 3.1.2.6.11);
- b) data link capability reporting (3.1.2.6.10.2.2); and
- c) aircraft identification reporting (3.1.2.9).

*Note.*— *Level 2 permits aircraft identification reporting and other standard length data link communications from ground to air and air to ground. The aircraft identification reporting capability requires an interface and appropriate input device.*

2.1.5.1.3 Level 3 — Level 3 transponders shall have the capabilities of 2.1.5.1.2 and also those prescribed for ground-to-air extended length message (ELM) communications (3.1.2.7.1 to 3.1.2.7.5).

*Note.*— *Level 3 permits extended length data link communications from ground to air and thus may provide retrieval from ground-based data banks and receipt of other air traffic services which are not available with Level 2 transponders.*

2.1.5.1.4 Level 4 — Level 4 transponders shall have the capabilities of 2.1.5.1.3 and also those prescribed for air-to-ground extended length message (ELM) communications (3.1.2.7.7 and 3.1.2.7.8).

*Note.*— Level 4 permits extended length data link communications from air to ground and thus may provide access from the ground to airborne data sources and the transmission of other data required by air traffic services which are not available with Level 2 transponders.

2.1.5.1.5 Level 5 — Level 5 transponders shall have the capabilities of 2.1.5.1.4 and also those prescribed for enhanced Comm-B and extended length message (ELM) communications (3.1.2.6.11.3.4, 3.1.2.7.6 and 3.1.2.7.9).

*Note.*— Level 5 permits Comm-B and extended length data link communications with multiple interrogators without requiring the use of multisite reservations. This level of transponder has a higher minimum data link capacity than the other transponder levels.

2.1.5.1.6 *Extended squitter* — Extended squitter transponders shall have the capabilities of 2.1.5.1.2, 2.1.5.1.3, 2.1.5.1.4 or 2.1.5.1.5, the capabilities prescribed for extended squitter operation (3.1.2.8.6) and the capabilities prescribed for ACAS cross-link operation (3.1.2.8.3 and 3.1.2.8.4). Transponders with these capabilities shall be designated with a suffix “e”.

*Note.*— For example, a level 4 transponder with extended squitter capability would be designated “level 4e”.

2.1.5.1.7 *SI capability* — Transponders with the ability to process SI codes shall have the capabilities of 2.1.5.1.1, 2.1.5.1.2, 2.1.5.1.3, 2.1.5.1.4 or 2.1.5.1.5 and also those prescribed for SI code operation (3.1.2.3.2.1.4, 3.1.2.5.2.1, 3.1.2.6.1.3, 3.1.2.6.1.4.1, 3.1.2.6.9.1.1 and 3.1.2.6.9.2). Transponders with this capability shall be designated with a suffix “s”.

*Note.*— For example, a level 4 transponder with extended squitter capability and SI capability would be designated “level 4es”.

2.1.5.1.7.1 SI code capability shall be provided in accordance with the provisions of 2.1.5.1.7 for all Mode S transponders installed on or after 1 January 2003 and by all Mode S transponders by 1 January 2005.

*Note.*— Mandates from certain States may require applicability in advance of these dates.

2.1.5.1.8 *Extended squitter non-transponder devices.* Devices that are capable of broadcasting extended squitters that are not part of a Mode S transponder shall conform to all of the 1 090 MHz RF signals in space requirements specified for a Mode S transponder, except for transmit power levels for the identified equipment class as specified in 5.1.1.

2.1.5.2 All Mode S transponders used by international civil air traffic shall conform, at least, to the requirements of Level 2 prescribed in 2.1.5.1.2.

*Note 1.*— Level 1 may be admitted for use within an individual State or within the terms of a regional air navigation agreement. The Mode S Level 1 transponder comprises the minimum set of features for compatible operation of Mode S transponders with SSR Mode S interrogators. It is defined to prevent a proliferation of transponder types below Level 2 which would be incompatible with SSR Mode S interrogators.

*Note 2.*— The intent of the requirement for a Level 2 capability is to ensure the widespread use of an ICAO standard transponder capability to allow worldwide planning of Mode S ground facilities and services. The requirement also discourages an initial installation with Level 1 transponders that would be rendered obsolete by later requirements in certain airspace for mandatory carriage of transponders having Level 2 capabilities.

2.1.5.3 Mode S transponders installed on aircraft with gross mass in excess of 5 700 kg or a maximum cruising true airspeed capability in excess of 463 km/h (250 kt) shall operate with antenna diversity as prescribed in 3.1.2.10.4 if:

- a) the aircraft individual certificate of airworthiness is first issued on or after 1 January 1990; or
- b) Mode S transponder carriage is required on the basis of regional air navigation agreement in accordance with 2.1.3.3.1 and 2.1.3.3.2.

*Note.*— Aircraft with maximum cruising true airspeed exceeding 324 km/h (175 kt) are required to operate with a peak power of not less than 21.0 dBW as specified in 3.1.2.10.2 c).

#### 2.1.5.4 CAPABILITY REPORTING IN MODE S SQUITTERS

2.1.5.4.1 Capability reporting in Mode S acquisition squitters (unsolicited downlink transmissions) shall be provided in accordance with the provisions of 3.1.2.8.5.1 for all Mode S transponders installed on or after 1 January 1995.

2.1.5.4.2 **Recommendation.**— *Transponders equipped for extended squitter operation should have a means to disable acquisition squitters when extended squitters are being emitted.*

*Note.*— *This will facilitate the suppression of acquisition squitters if all ACAS units have been converted to receive the extended squitter.*

#### 2.1.5.5 EXTENDED LENGTH MESSAGE (ELM) TRANSMIT POWER

In order to facilitate the conversion of existing Mode S transponders to include full Mode S capability, transponders originally manufactured before 1 January 1999 shall be permitted to transmit a burst of 16 ELM segments at a minimum power level of 20 dBW.

*Note.*— *This represents a 1 dB relaxation from the power requirement specified in 3.1.2.10.2.*

### 2.1.6 SSR Mode S address (aircraft address)

The SSR Mode S address shall be one of 16 777 214 twenty-four-bit aircraft addresses allocated by ICAO to the State of Registry or common mark registering authority and assigned as prescribed in 3.1.2.4.1.2.3.1.1 and the Appendix to Chapter 9, Part I, Volume III, Annex 10.

## 2.2 HUMAN FACTORS CONSIDERATIONS

**Recommendation.**— *Human Factors principles should be observed in the design and certification of surveillance radar and collision avoidance systems.*

*Note.*— *Guidance material on Human Factors principles can be found in Doc 9683, Human Factors Training Manual and Circular 249 (Human Factors Digest No. 11 — Human Factors in CNS/ATM Systems).*

## CHAPTER 3. SURVEILLANCE SYSTEMS

### 3.1 SECONDARY SURVEILLANCE RADAR (SSR) SYSTEM CHARACTERISTICS

*Note 1.— Section 3.1.1 prescribes the technical characteristics of SSR systems having only Mode A and Mode C capabilities. Section 3.1.2 prescribes the characteristics of systems with Mode S capabilities. Chapter 5 prescribes additional requirements on Mode S extended squitters.*

*Note 2.— Systems using Mode S capabilities are generally used for air traffic control surveillance systems. In addition, certain ATC applications may use Mode S emitters, e.g. for vehicle surface surveillance or for fixed target detection on surveillance systems. Under such specific conditions, the term “aircraft” can be understood as “aircraft or vehicle (A/V)”. While those applications may use a limited set of data, any deviation from standard physical characteristics must be considered very carefully by the appropriate authorities. They must take into account not only their own surveillance (SSR) environment but also possible effects on other systems like ACAS.*

*Note 3.— Non-Standard-International alternative units are used as permitted by Annex 5, Chapter 3, 3.2.2.*

#### 3.1.1 Systems having only Mode A and Mode C capabilities

*Note 1.— In this section, SSR modes are designated by letters A and C. Suffixes letters, e.g. A<sub>2</sub>, C<sub>4</sub>, are used to designate the individual pulses used in the air-to-ground pulse trains. This common use of letters is not to be construed as implying any particular association of modes and codes.*

*Note 2.— Provisions for the recording and retention of radar data are contained in Annex 11, Chapter 6.*

##### 3.1.1.1 INTERROGATION AND CONTROL (INTERROGATION SIDE-LOBE SUPPRESSION) RADIO FREQUENCIES (GROUND-TO-AIR)

3.1.1.1.1 The carrier frequency of the interrogation and control transmissions shall be 1 030 MHz.

3.1.1.1.2 The frequency tolerance shall be plus or minus 0.2 MHz.

3.1.1.1.3 The carrier frequencies of the control transmission and of each of the interrogation pulse transmissions shall not differ from each other by more than 0.2 MHz.

##### 3.1.1.2 REPLY CARRIER FREQUENCY (AIR-TO-GROUND)

3.1.1.2.1 The carrier frequency of the reply transmission shall be 1 090 MHz.

3.1.1.2.2 The frequency tolerance shall be plus or minus 3 MHz.

## 3.1.1.3 POLARIZATION

Polarization of the interrogation, control and reply transmissions shall be predominantly vertical.

## 3.1.1.4 INTERROGATION MODES (SIGNALS-IN-SPACE)

3.1.1.4.1 The interrogation shall consist of two transmitted pulses designated  $P_1$  and  $P_3$ . A control pulse  $P_2$  shall be transmitted following the first interrogation pulse  $P_1$ .

3.1.1.4.2 Interrogation Modes A and C shall be as defined in 3.1.1.4.3.

3.1.1.4.3 The interval between  $P_1$  and  $P_3$  shall determine the mode of interrogation and shall be as follows:

Mode A	8 ±0.2 microseconds
Mode C	21 ±0.2 microseconds

3.1.1.4.4 The interval between  $P_1$  and  $P_2$  shall be 2.0 plus or minus 0.15 microseconds.

3.1.1.4.5 The duration of pulses  $P_1$ ,  $P_2$  and  $P_3$  shall be 0.8 plus or minus 0.1 microsecond.

3.1.1.4.6 The rise time of pulses  $P_1$ ,  $P_2$  and  $P_3$  shall be between 0.05 and 0.1 microsecond.

*Note 1.— The definitions are contained in Figure 3-1 “Definitions of secondary surveillance radar waveform shapes, intervals and the reference point for sensitivity and power”.*

*Note 2.— The intent of the lower limit of rise time (0.05 microsecond) is to reduce sideband radiation. Equipment will meet this requirement if the sideband radiation is no greater than that which, theoretically, would be produced by a trapezoidal wave having the stated rise time.*

3.1.1.4.7 The decay time of pulses  $P_1$ ,  $P_2$  and  $P_3$  shall be between 0.05 and 0.2 microsecond.

*Note.— The intent of the lower limit of decay time (0.05 microsecond) is to reduce sideband radiation. Equipment will meet this requirement if the sideband radiation is no greater than that which, theoretically, would be produced by a trapezoidal wave having the stated decay time.*

3.1.1.5 INTERROGATOR AND CONTROL TRANSMISSION CHARACTERISTICS  
(INTERROGATION SIDE-LOBE SUPPRESSION — SIGNALS-IN-SPACE)

3.1.1.5.1 The radiated amplitude of  $P_2$  at the antenna of the transponder shall be:

- a) equal to or greater than the radiated amplitude of  $P_1$  from the side-lobe transmissions of the antenna radiating  $P_1$ ; and
- b) at a level lower than 9 dB below the radiated amplitude of  $P_1$ , within the desired arc of interrogation.

3.1.1.5.2 Within the desired beam width of the directional interrogation (main lobe), the radiated amplitude of  $P_3$  shall be within 1 dB of the radiated amplitude of  $P_1$ .



## 3.1.1.6 REPLY TRANSMISSION CHARACTERISTICS (SIGNALS-IN-SPACE)

3.1.1.6.1 Framing pulses. The reply function shall employ a signal comprising two framing pulses spaced 20.3 microseconds as the most elementary code.

3.1.1.6.2 Information pulses. Information pulses shall be spaced in increments of 1.45 microseconds from the first framing pulse. The designation and position of these information pulses shall be as follows:

<i>Pulses</i>	<i>Position (microseconds)</i>
C <sub>1</sub>	1.45
A <sub>1</sub>	2.90
C <sub>2</sub>	4.35
A <sub>2</sub>	5.80
C <sub>4</sub>	7.25
A <sub>4</sub>	8.70
X	10.15
B <sub>1</sub>	11.60
D <sub>1</sub>	13.05
B <sub>2</sub>	14.50
D <sub>2</sub>	15.95
B <sub>4</sub>	17.40
D <sub>4</sub>	18.85

*Note.*— The Standard relating to the use of these pulses is given in 2.1.4.1. However, the position of the “X” pulse is not used in replies to Mode A or Mode C interrogations and is specified only as a technical standard to safeguard possible future expansion of the system. It has nevertheless been decided that such expansion should be achieved using Mode S. The presence of a pulse in the X pulse position is used in some States to invalidate replies.

3.1.1.6.3 *Special position identification pulse (SPI).* In addition to the information pulses provided, a special position identification pulse shall be transmitted but only as a result of manual (pilot) selection. When transmitted, it shall be spaced at an interval of 4.35 microseconds following the last framing pulse of Mode A replies only.

3.1.1.6.4 *Reply pulse shape.* All reply pulses shall have a pulse duration of 0.45 plus or minus 0.1 microsecond, a pulse rise time between 0.05 and 0.1 microsecond and a pulse decay time between 0.05 and 0.2 microsecond. The pulse amplitude variation of one pulse with respect to any other pulse in a reply train shall not exceed 1 dB.

*Note.*— The intent of the lower limit of rise and decay times (0.05 microsecond) is to reduce sideband radiation. Equipment will meet this requirement if the sideband radiation is not greater than that which, theoretically, would be produced by a trapezoidal wave having the stated rise and decay times.

3.1.1.6.5 *Reply pulse position tolerances.* The pulse spacing tolerance for each pulse (including the last framing pulse) with respect to the first framing pulse of the reply group shall be plus or minus 0.10 microsecond. The pulse interval tolerance of the special position identification pulse with respect to the last framing pulse of the reply group shall be plus or minus 0.10 microsecond. The pulse spacing tolerance of any pulse in the reply group with respect to any other pulse (except the first framing pulse) shall not exceed plus or minus 0.15 microsecond.

3.1.1.6.6 *Code nomenclature.* The code designation shall consist of digits between 0 and 7 inclusive, and shall consist of the sum of the subscripts of the pulse numbers given in 3.1.1.6.2 above, employed as follows:

<i>Digit</i>	<i>Pulse Group</i>
First (most significant)	A
Second	B
Third	C
Fourth	D

### 3.1.1.7 TECHNICAL CHARACTERISTICS OF TRANSPONDERS WITH MODE A AND MODE C CAPABILITIES ONLY

3.1.1.7.1 *Reply.* The transponder shall reply (not less than 90 per cent triggering) when all of the following conditions have been met:

- the received amplitude of  $P_3$  is in excess of a level 1 dB below the received amplitude of  $P_1$  but no greater than 3 dB above the received amplitude of  $P_1$ ;
- either no pulse is received in the interval 1.3 microseconds to 2.7 microseconds after  $P_1$ , or  $P_1$  exceeds by more than 9 dB any pulse received in this interval;
- the received amplitude of a proper interrogation is more than 10 dB above the received amplitude of random pulses where the latter are not recognized by the transponder as  $P_1$ ,  $P_2$  or  $P_3$ .

3.1.1.7.2 The transponder shall not reply under the following conditions:

- to interrogations when the interval between pulses  $P_1$  and  $P_3$  differs from those specified in 3.1.1.4.3 by more than plus or minus 1.0 microsecond;
- upon receipt of any single pulse which has no amplitude variations approximating a normal interrogation condition.

3.1.1.7.3 *Dead time.* After recognition of a proper interrogation, the transponder shall not reply to any other interrogation, at least for the duration of the reply pulse train. This dead time shall end no later than 125 microseconds after the transmission of the last reply pulse of the group.

#### 3.1.1.7.4 SUPPRESSION

*Note.— This characteristic is used to prevent replies to interrogations received via the side lobes of the interrogator antenna, and to prevent Mode A/C transponders from replying to Mode S interrogations.*

3.1.1.7.4.1 The transponder shall be suppressed when the received amplitude of  $P_2$  is equal to, or in excess of, the received amplitude of  $P_1$  and spaced 2.0 plus or minus 0.15 microseconds. The detection of  $P_3$  is not required as a prerequisite for initiation of suppression action.

3.1.1.7.4.2 The transponder suppression shall be for a period of 35 plus or minus 10 microseconds.

3.1.1.7.4.2.1 The suppression shall be capable of being reinitiated for the full duration within 2 microseconds after the end of any suppression period.

3.1.1.7.4.3 Suppression in presence of  $S_1$  pulse

*Note.*— The  $S_1$  pulse is used in a technique employed by ACAS known as “whisper-shout” to facilitate ACAS surveillance of Mode A/C aircraft in higher traffic densities. The whisper-shout technique is explained in the Airborne Collision Avoidance System (ACAS) Manual (Doc 9863).

When an  $S_1$  pulse is detected 2.0 plus or minus 0.15 microseconds before the  $P_1$  of a Mode A or Mode C interrogation:

- a) with  $S_1$  and  $P_1$  above MTL, the transponder shall be suppressed as specified in 3.1.1.7.4.1;
- b) with  $P_1$  at MTL and  $S_1$  at MTL, the transponder shall be suppressed and shall reply to no more than 10 per cent of Mode A/C interrogations;
- c) with  $P_1$  at MTL and  $S_1$  at MTL -3 dB, the transponder shall reply to Mode A/C interrogations at least 70 per cent of the time; and
- d) with  $P_1$  at MTL and  $S_1$  at MTL -6 dB, the transponder shall reply to Mode A/C interrogations at least 90 per cent of the time.

*Note 1.*— The suppression action is because of the detection of  $S_1$  and  $P_1$  and does not require detection of a  $P_2$  or  $P_3$  pulse.

*Note 2.*—  $S_1$  has a lower amplitude than  $P_1$ . Certain ACAS use this mechanism to improve target detection (4.3.7.1).

*Note 3.*— These requirements also apply to a Mode A/C only capable transponder when an  $S_1$  precedes an intermode interrogation (2.1.2.1).

## 3.1.1.7.5 RECEIVER SENSITIVITY AND DYNAMIC RANGE

3.1.1.7.5.1 The minimum triggering level of the transponder shall be such that replies are generated to at least 90 per cent of the interrogation signals when:

- a) the two pulses  $P_1$  and  $P_3$  constituting an interrogation are of equal amplitude and  $P_2$  is not detected; and
- b) the amplitude of these signals is nominally 71 dB below 1 mW, with limits between 69 dB and 77 dB below 1 mW.

3.1.1.7.5.2 The reply and suppression characteristics shall apply over a received amplitude of  $P_1$  between minimum triggering level and 50 dB above that level.

3.1.1.7.5.3 The variation of the minimum triggering level between modes shall not exceed 1 dB for nominal pulse spacings and pulse widths.

3.1.1.7.6 *Pulse duration discrimination.* Signals of received amplitude between minimum triggering level and 6 dB above this level, and of a duration less than 0.3 microsecond, shall not cause the transponder to initiate reply or suppression action. With the exception of single pulses with amplitude variations approximating an interrogation, any single pulse of a duration more than 1.5 microseconds shall not cause the transponder to initiate reply or suppression action over the signal amplitude range of minimum triggering level (MTL) to 50 dB above that level.

3.1.1.7.7 *Echo suppression and recovery.* The transponder shall contain an echo suppression facility designed to permit normal operation in the presence of echoes of signals-in-space. The provision of this facility shall be compatible with the requirements for suppression of side lobes given in 3.1.1.7.4.1.

3.1.1.7.7.1 *Desensitization.* Upon receipt of any pulse more than 0.7 microsecond in duration, the receiver shall be desensitized by an amount that is within at least 9 dB of the amplitude of the desensitizing pulse but shall at no time exceed the amplitude of the desensitizing pulse, with the exception of possible overshoot during the first microsecond following the desensitizing pulse.

*Note.*— Single pulses of duration less than 0.7 microsecond are not required to cause the specified desensitization nor to cause desensitization of duration greater than permitted by 3.1.1.7.7.1 and 3.1.1.7.7.2.

3.1.1.7.7.2 *Recovery.* Following desensitization, the receiver shall recover sensitivity (within 3 dB of minimum triggering level) within 15 microseconds after reception of a desensitizing pulse having a signal strength up to 50 dB above minimum triggering level. Recovery shall be at an average rate not exceeding 4.0 dB per microsecond.

3.1.1.7.8 *Random triggering rate.* In the absence of valid interrogation signals, Mode A/C transponders shall not generate more than 30 unwanted Mode A or Mode C replies per second as integrated over an interval equivalent to at least 300 random triggers, or 30 seconds, whichever is less. This random triggering rate shall not be exceeded when all possible interfering equipments installed in the same aircraft are operating at maximum interference levels.

3.1.1.7.8.1 *Random triggering rate in the presence of low-level in-band continuous wave (CW) interference.* The total random trigger rate on all Mode A and/or Mode C replies shall not be greater than 10 reply pulse groups or suppressions per second, averaged over a period of 30 seconds, when operated in the presence of non-coherent CW interference at a frequency of  $1\ 030 \pm 0.2$  MHz and a signal level of  $-60$  dBm or less.

#### 3.1.1.7.9 *REPLY RATE*

3.1.1.7.9.1 All transponders shall be capable of continuously generating at least 500 replies per second for a 15-pulse coded reply. Transponder installations used solely below 4 500 m (15 000 ft), or below a lesser altitude established by the appropriate authority or by regional air navigation agreement, and in aircraft with a maximum cruising true airspeed not exceeding 175 kt (324 km/h) shall be capable of generating at least 1 000 15-pulse coded replies per second for a duration of 100 milliseconds. Transponder installations operated above 4 500 m (15 000 ft) or in aircraft with a maximum cruising true airspeed in excess of 175 kt (324 km/h), shall be capable of generating at least 1 200 15-pulse coded replies per second for a duration of 100 milliseconds.

*Note.*— A 15-pulse reply includes 2 framing pulses, 12 information pulses, and the SPI pulse.

3.1.1.7.9.2 *Reply rate limit control.* To protect the system from the effects of transponder over-interrogation by preventing response to weaker signals when a predetermined reply rate has been reached, a sensitivity reduction type reply limit control shall be incorporated in the equipment. The range of this control shall permit adjustment, as a minimum, to any value between 500 and 2 000 replies per second, or to the maximum reply rate capability if less than 2 000 replies per second, without regard to the number of pulses in each reply. Sensitivity reduction in excess of 3 dB shall not take effect until 90 per cent of the selected value is exceeded. Sensitivity reduction shall be at least 30 dB for rates in excess of 150 per cent of the selected value.

3.1.1.7.10 *Reply delay and jitter.* The time delay between the arrival, at the transponder receiver, of the leading edge of  $P_3$  and the transmission of the leading edge of the first pulse of the reply shall be 3 plus or minus 0.5 microseconds. The total jitter of the reply pulse code group, with respect to  $P_3$ , shall not exceed 0.1 microsecond for receiver input levels between 3 dB and 50 dB above minimum triggering level. Delay variations between modes on which the transponder is capable of replying shall not exceed 0.2 microsecond.

#### 3.1.1.7.11 *TRANSPONDER POWER OUTPUT AND DUTY CYCLE*

3.1.1.7.11.1 The peak pulse power available at the antenna end of the transmission line of the transponder shall be at least 21 dB and not more than 27 dB above 1 W, except that for transponder installations used solely below 4 500 m (15 000 ft), or

below a lesser altitude established by the appropriate authority or by regional air navigation agreement, a peak pulse power available at the antenna end of the transmission line of the transponder of at least 18.5 dB and not more than 27 dB above 1 W shall be permitted.

*Note.*— *An extended squitter non-transponder device on an aerodrome surface vehicle may operate with a lower minimum power output as specified in 5.1.1.2.*

3.1.1.7.11.2 **Recommendation.**— *The peak pulse power specified in 3.1.1.7.11.1 should be maintained over a range of replies from code 0000 at a rate of 400 replies per second to a maximum pulse content at a rate of 1 200 replies per second or a maximum value below 1 200 replies per second of which the transponder is capable.*

#### 3.1.1.7.12 REPLY CODES

3.1.1.7.12.1 *Identification.* The reply to a Mode A interrogation shall consist of the two framing pulses specified in 3.1.1.6.1 together with the information pulses (Mode A code) specified in 3.1.1.6.2.

*Note.*— *The Mode A code designation is a sequence of four digits in accordance with 3.1.1.6.6.*

3.1.1.7.12.1.1 The Mode A code shall be manually selected from the 4 096 codes available.

3.1.1.7.12.2 *Pressure-altitude transmission.* The reply to Mode C interrogation shall consist of the two framing pulses specified in 3.1.1.6.1 above. When digitized pressure-altitude information is available, the information pulses specified in 3.1.1.6.2 shall also be transmitted.

3.1.1.7.12.2.1 Transponders shall be provided with means to remove the information pulses but to retain the framing pulses when the provision of 3.1.1.7.12.2.4 below is not complied with in reply to Mode C interrogation.

3.1.1.7.12.2.2 The information pulses shall be automatically selected by an analog-to-digital converter connected to a pressure-altitude data source in the aircraft referenced to the standard pressure setting of 1 013.25 hectopascals.

*Note.*— *The pressure setting of 1 013.25 hectopascals is equal to 29.92 inches of mercury.*

3.1.1.7.12.2.3 Pressure-altitude shall be reported in 100-ft increments by selection of pulses as shown in the Appendix to this chapter.

3.1.1.7.12.2.4 The digitizer code selected shall correspond to within plus or minus 38.1 m (125 ft), on a 95 per cent probability basis, with the pressure-altitude information (referenced to the standard pressure setting of 1 013.25 hectopascals), used on board the aircraft to adhere to the assigned flight profile.

3.1.1.7.13 *Transmission of the special position identification (SPI) pulse.* When required, this pulse shall be transmitted with Mode A replies, as specified in 3.1.1.6.3, for a period of between 15 and 30 seconds.

#### 3.1.1.7.14 ANTENNA

3.1.1.7.14.1 The transponder antenna system, when installed on an aircraft, shall have a radiation pattern which is essentially omnidirectional in the horizontal plane.

3.1.1.7.14.2 **Recommendation.**— *The vertical radiation pattern should be nominally equivalent to that of a quarter-wave monopole on a ground plane.*

### 3.1.1.8 TECHNICAL CHARACTERISTICS OF GROUND INTERROGATORS WITH MODE A AND MODE C CAPABILITIES ONLY

3.1.1.8.1 *Interrogation repetition frequency.* The maximum interrogation repetition frequency shall be 450 interrogations per second.

3.1.1.8.1.1 **Recommendation.**— *To minimize unnecessary transponder triggering and the resulting high density of mutual interference, all interrogators should use the lowest practicable interrogator repetition frequency that is consistent with the display characteristics, interrogator antenna beam width and antenna rotation speed employed.*

#### 3.1.1.8.2 RADIATED POWER

**Recommendation.**— *In order to minimize system interference the effective radiated power of interrogators should be reduced to the lowest value consistent with the operationally required range of each individual interrogator site.*

3.1.1.8.3 **Recommendation.**— *When Mode C information is to be used from aircraft flying below transition levels, the altimeter pressure reference datum should be taken into account.*

*Note.*— *Use of Mode C below transition levels is in accordance with the philosophy that Mode C can usefully be employed in all environments.*

### 3.1.1.9 INTERROGATOR RADIATED FIELD PATTERN

**Recommendation.**— *The beam width of the directional interrogator antenna radiating  $P_3$  should not be wider than is operationally required. The side- and back-lobe radiation of the directional antenna should be at least 24 dB below the peak of the main-lobe radiation.*

#### 3.1.1.10 INTERROGATOR MONITOR

3.1.1.10.1 The range and azimuth accuracy of the ground interrogator shall be monitored at sufficiently frequent intervals to ensure system integrity.

*Note.*— *Interrogators that are associated with and operated in conjunction with primary radar may use the primary radar as the monitoring device; alternatively, an electronic range and azimuth accuracy monitor would be required.*

3.1.1.10.2 **Recommendation.**— *In addition to range and azimuth monitoring, provision should be made to monitor continuously the other critical parameters of the ground interrogator for any degradation of performance exceeding the allowable system tolerances and to provide an indication of any such occurrence.*

### 3.1.1.11 SPURIOUS EMISSIONS AND SPURIOUS RESPONSES

#### 3.1.1.11.1 SPURIOUS RADIATION

**Recommendation.**— *CW radiation should not exceed 76 dB below 1 W for the interrogator and 70 dB below 1 W for the transponder.*

## 3.1.1.11.2 SPURIOUS RESPONSES

**Recommendation.**— *The response of both airborne and ground equipment to signals not within the receiver pass band should be at least 60 dB below normal sensitivity.*

## 3.1.2 Systems having Mode S capabilities

3.1.2.1 *Interrogation signals-in-space characteristics.* The paragraphs herein describe the signals-in-space as they can be expected to appear at the antenna of the transponder.

*Note.*— *Because signals can be corrupted in propagation, certain interrogation pulse duration, pulse spacing and pulse amplitude tolerances are more stringent for interrogators as described in 3.1.2.11.4.*

3.1.2.1.1 *Interrogation carrier frequency.* The carrier frequency of all interrogations (uplink transmissions) from ground facilities with Mode S capabilities shall be 1 030 plus or minus 0.01 MHz.

3.1.2.1.2 *Interrogation spectrum.* The spectrum of a Mode S interrogation about the carrier frequency shall not exceed the limits specified in Figure 3-2.

*Note.*— *The Mode S interrogation spectrum is data dependent. The broadest spectrum is generated by an interrogation that contains all binary ONES.*

3.1.2.1.3 *Polarization.* Polarization of the interrogation and control transmissions shall be nominally vertical.

3.1.2.1.4 *Modulation.* For Mode S interrogations, the carrier frequency shall be pulse modulated. In addition, the data pulse,  $P_6$ , shall have internal phase modulation.

3.1.2.1.4.1 *Pulse modulation.* Intermode and Mode S interrogations shall consist of a sequence of pulses as specified in 3.1.2.1.5 and Tables 3-1, 3-2, 3-3, and 3-4.

*Note.*— *The 0.8 microsecond pulses used in intermode and Mode S interrogations are identical in shape to those used in Modes A and C as defined in 3.1.1.4.*

3.1.2.1.4.2 *Phase modulation.* The short (16.25-microsecond) and long (30.25-microsecond)  $P_6$  pulses of 3.1.2.1.4.1 shall have internal binary differential phase modulation consisting of 180-degree phase reversals of the carrier at a 4 megabit per second rate.

3.1.2.1.4.2.1 *Phase reversal duration.* The duration of the phase reversal shall be less than 0.08 microsecond and the phase shall advance (or retard) monotonically throughout the transition region. There shall be no amplitude modulation applied during the phase transition.

*Note.*— *The minimum duration of the phase reversal is not specified. Nonetheless, the spectrum requirements of 3.1.2.1.2 must be met.*

3.1.2.1.4.2.2 *Phase relationship.* The tolerance on the 0 and 180-degree phase relationship between successive chips and on the sync phase reversal (3.1.2.1.5.2.2) within the  $P_6$  pulse shall be plus or minus 5 degrees.

*Note.*— *In Mode S a “chip” is the 0.25 microsecond carrier interval between possible data phase reversals.*

3.1.2.1.5 *Pulse and phase reversal sequences.* Specific sequences of the pulses or phase reversals described in 3.1.2.1.4 shall constitute interrogations.

### 3.1.2.1.5.1 Intermode interrogation

3.1.2.1.5.1.1 *Mode A/C/S all-call interrogation.* This interrogation shall consist of three pulses:  $P_1$ ,  $P_3$ , and the long  $P_4$  as shown in Figure 3-3. One or two control pulses ( $P_2$  alone, or  $P_1$  and  $P_2$ ) shall be transmitted using a separate antenna pattern to suppress responses from aircraft in the side lobes of the interrogator antenna.

*Note.*— The Mode A/C/S all-call interrogation elicits a Mode A or Mode C reply (depending on the  $P_1$ - $P_3$  pulse spacing) from a Mode A/C transponder because it does not recognize the  $P_4$  pulse. A Mode S transponder recognizes the long  $P_4$  pulse and responds with a Mode S reply. This interrogation was originally planned for use by isolated or clustered interrogators. Lockout for this interrogation was based on the use of  $II$  equals 0. The development of the Mode S subnetwork now dictates the use of a non-zero  $II$  code for communication purposes. For this reason,  $II$  equals 0 has been reserved for use in support of a form of Mode S acquisition that uses stochastic/lockout override (3.1.2.5.2.1.4 and 3.1.2.5.2.1.5). The Mode A/C/S all-call cannot be used with full Mode S operation since  $II$  equals 0 can only be locked out for short time periods (3.1.2.5.2.1.5.2.1). This interrogation cannot be used with stochastic/lockout override, since probability of reply cannot be specified.

3.1.2.1.5.1.2 *Mode A/C-only all-call interrogation.* This interrogation shall be identical to that of the Mode A/C/S all-call interrogation except that the short  $P_4$  pulse shall be used.

*Note.*— The Mode A/C-only all-call interrogation elicits a Mode A or Mode C reply from a Mode A/C transponder. A Mode S transponder recognizes the short  $P_4$  pulse and does not reply to this interrogation.

3.1.2.1.5.1.3 *Pulse intervals.* The pulse intervals between  $P_1$ ,  $P_2$  and  $P_3$  shall be as defined in 3.1.1.4.3 and 3.1.1.4.4. The pulse interval between  $P_3$  and  $P_4$  shall be 2 plus or minus 0.05 microsecond.

3.1.2.1.5.1.4 *Pulse amplitudes.* Relative amplitudes between pulses  $P_1$ ,  $P_2$  and  $P_3$  shall be in accordance with 3.1.1.5. The amplitude of  $P_4$  shall be within 1 dB of the amplitude of  $P_3$ .

3.1.2.1.5.2 *Mode S interrogation.* The Mode S interrogation shall consist of three pulses:  $P_1$ ,  $P_2$  and  $P_6$  as shown in Figure 3-4.

*Note.*—  $P_6$  is preceded by a  $P_1 - P_2$  pair which suppresses replies from Mode A/C transponders to avoid synchronous garble due to random triggering by the Mode S interrogation. The sync phase reversal within  $P_6$  is the timing mark for demodulation of a series of time intervals (chips) of 0.25 microsecond duration. This series of chips starts 0.5 microsecond after the sync phase reversal and ends 0.5 microsecond before the trailing edge of  $P_6$ . A phase reversal may or may not precede each chip to encode its binary information value.

3.1.2.1.5.2.1 *Mode S side-lobe suppression.* The  $P_5$  pulse shall be used with the Mode S-only all-call interrogation (UF = 11, see 3.1.2.5.2) to prevent replies from aircraft in the side and back lobes of the antenna (3.1.2.1.5.2.5). When used,  $P_5$  shall be transmitted using a separate antenna pattern.

*Note 1.*— The action of  $P_5$  is automatic. Its presence, if of sufficient amplitude at the receiving location, masks the sync phase reversal of  $P_6$ .

*Note 2.*— The  $P_5$  pulse may be used with other Mode S interrogations.

3.1.2.1.5.2.2 *Sync phase reversal.* The first phase reversal in the  $P_6$  pulse shall be the sync phase reversal. It shall be the timing reference for subsequent transponder operations related to the interrogation.

3.1.2.1.5.2.3 *Data phase reversals.* Each data phase reversal shall occur only at a time interval (N times 0.25) plus or minus 0.02 microsecond (N equal to, or greater than 2) after the sync phase reversal. The 16.25-microsecond  $P_6$  pulse shall contain at most 56 data phase reversals. The 30.25-microsecond  $P_6$  pulse shall contain at most 112 data phase reversals. The last chip, that is the 0.25-microsecond time interval following the last data phase reversal position, shall be followed by a 0.5-microsecond guard interval.



*Note.*— The 0.5-microsecond guard interval following the last chip prevents the trailing edge of  $P_6$  from interfering with the demodulation process.

3.1.2.1.5.2.4 *Intervals.* The pulse interval between  $P_1$  and  $P_2$  shall be 2 plus or minus 0.05 microsecond. The interval between the leading edge of  $P_2$  and the sync phase reversal of  $P_6$  shall be 2.75 plus or minus 0.05 microsecond. The leading edge of  $P_6$  shall occur 1.25 plus or minus 0.05 microsecond before the sync phase reversal.  $P_5$ , if transmitted, shall be centred over the sync phase reversal; the leading edge of  $P_5$  shall occur 0.4 plus or minus 0.05 microsecond before the sync phase reversal.

3.1.2.1.5.2.5 *Pulse amplitudes.* The amplitude of  $P_2$  and the amplitude of the first microsecond of  $P_6$  shall be greater than the amplitude of  $P_1$  minus 0.25 dB. Exclusive of the amplitude transients associated with phase reversals, the amplitude variation of  $P_6$  shall be less than 1 dB and the amplitude variation between successive chips in  $P_6$  shall be less than 0.25 dB. The radiated amplitude of  $P_5$  at the antenna of the transponder shall be:

- a) equal to or greater than the radiated amplitude of  $P_6$  from the side-lobe transmissions of the antenna radiating  $P_6$ ; and
- b) at a level lower than 9 dB below the radiated amplitude of  $P_6$  within the desired arc of interrogation.

### 3.1.2.2 REPLY SIGNALS-IN-SPACE CHARACTERISTICS

3.1.2.2.1 *Reply carrier frequency.* The carrier frequency of all replies (downlink transmissions) from transponders with Mode S capabilities shall be 1 090 plus or minus 1 MHz.

3.1.2.2.2 *Reply spectrum.* The spectrum of a Mode S reply about the carrier frequency shall not exceed the limits specified in Figure 3-5.

3.1.2.2.3 *Polarization.* Polarization of the reply transmissions shall be nominally vertical.

3.1.2.2.4 *Modulation.* The Mode S reply shall consist of a preamble and a data block. The preamble shall be a 4-pulse sequence and the data block shall be binary pulse-position modulated at a 1 megabit per second data rate.

3.1.2.2.4.1 *Pulse shapes.* Pulse shapes shall be as defined in Table 3-2. All values are in microseconds.

3.1.2.2.5 *Mode S reply.* The Mode S reply shall be as shown in Figure 3-6. The data block in Mode S replies shall consist of either 56 or 112 information bits.

3.1.2.2.5.1 *Pulse intervals.* All reply pulses shall start at a defined multiple of 0.5 microsecond from the first transmitted pulse. The tolerance in all cases shall be plus or minus 0.05 microsecond.

3.1.2.2.5.1.1 *Reply preamble.* The preamble shall consist of four pulses, each with a duration of 0.5 microsecond. The pulse intervals from the first transmitted pulse to the second, third and fourth transmitted pulses shall be 1, 3.5 and 4.5 microseconds, respectively.

3.1.2.2.5.1.2 *Reply data pulses.* The reply data block shall begin 8 microseconds after the leading edge of the first transmitted pulse. Either 56 or 112 one-microsecond bit intervals shall be assigned to each transmission. A 0.5-microsecond pulse shall be transmitted either in the first or in the second half of each interval. When a pulse transmitted in the second half of one interval is followed by another pulse transmitted in the first half of the next interval, the two pulses merge and a one-microsecond pulse shall be transmitted.

3.1.2.2.5.2 *Pulse amplitudes.* The pulse amplitude variation between one pulse and any other pulse in a Mode S reply shall not exceed 2 dB.

## 3.1.2.3 MODE S DATA STRUCTURE

## 3.1.2.3.1 DATA ENCODING

3.1.2.3.1.1 *Interrogation data.* The interrogation data block shall consist of the sequence of 56 or 112 data chips positioned after the data phase reversals within  $P_6$  (3.1.2.1.5.2.3). A 180-degree carrier phase reversal preceding a chip shall characterize that chip as a binary ONE. The absence of a preceding phase reversal shall denote a binary ZERO.

3.1.2.3.1.2 *Reply data.* The reply data block shall consist of 56 or 112 data bits formed by binary pulse position modulation encoding of the reply data as described in 3.1.2.2.5.1.2. A pulse transmitted in the first half of the interval shall represent a binary ONE whereas a pulse transmitted in the second half shall represent a binary ZERO.

3.1.2.3.1.3 *Bit numbering.* The bits shall be numbered in the order of their transmission, beginning with bit 1. Unless otherwise stated, numerical values encoded by groups (fields) of bits shall be encoded using positive binary notation and the first bit transmitted shall be the most significant bit (MSB). Information shall be coded in fields which consist of at least one bit.

*Note.*— In the description of Mode S formats the decimal equivalent of the binary code formed by the bit sequence within a field is used as the designator of the field function or command.

## 3.1.2.3.2 FORMATS OF MODE S INTERROGATIONS AND REPLIES

*Note.*— A summary of all Mode S interrogation and reply formats is presented in Figures 3-7 and 3-8. A summary of all fields appearing in uplink and downlink formats is given in Table 3-3 and a summary of all subfields is given in Table 3-4.

3.1.2.3.2.1 *Essential fields.* Every Mode S transmission shall contain two essential fields. One is a descriptor which shall uniquely define the format of the transmission. This shall appear at the beginning of the transmission for all formats. The descriptors are designated by the UF (uplink format) or DF (downlink format) fields. The second essential field shall be a 24-bit field appearing at the end of each transmission and shall contain parity information. In all uplink and in currently defined downlink formats parity information shall be overlaid either on the aircraft address (3.1.2.4.1.2.3.1) or on the interrogator identifier according to 3.1.2.3.3.2. The designators are AP (address/parity) or PI (parity/interrogator identifier).

*Note.*— The remaining coding space is used to transmit the mission fields. For specific functions, a specific set of mission fields is prescribed. Mode S mission fields have two-letter designators. Subfields may appear within mission fields. Mode S subfields are labelled with three-letter designators.

3.1.2.3.2.1.1 *UF: Uplink format.* This uplink format field (5 bits long except in format 24 where it is 2 bits long) shall serve as the uplink format descriptor in all Mode S interrogations and shall be coded according to Figure 3-7.

3.1.2.3.2.1.2 *DF: Downlink format.* This downlink format field (5 bits long except in format 24 where it is 2 bits long) shall serve as the downlink format descriptor in all Mode S replies and shall be coded according to Figure 3-8.

3.1.2.3.2.1.3 *AP: Address/parity.* This 24-bit (33-56 or 89-112) field shall appear in all uplink and currently defined downlink formats except the Mode S-only all-call reply, DF = 11. The field shall contain parity overlaid on the aircraft address according to 3.1.2.3.3.2.

3.1.2.3.2.1.4 *PI: Parity/interrogator identifier.* This 24-bit (33-56) or (89-112) downlink field shall have parity overlaid on the interrogator's identity code according to 3.1.2.3.3.2 and shall appear in the Mode S all-call reply, DF = 11 and in the extended squitter, DF = 17 or DF = 18. If the reply is made in response to a Mode A/C/S all-call, a Mode S-only all-call with CL field (3.1.2.5.2.1.3) and IC field (3.1.2.5.2.1.2) equal to 0, or is an acquisition or an extended squitter (3.1.2.8.5, 3.1.2.8.6 or 3.1.2.8.7), the II and the SI codes shall be 0.

3.1.2.3.2.2 *Unassigned coding space.* Unassigned coding space shall contain all ZEROs as transmitted by interrogators and transponders.

*Note.*— *Certain coding space indicated as unassigned in this section is reserved for other applications such as ACAS, data link, etc.*

3.1.2.3.2.3 *Zero and unassigned codes.* A zero code assignment in all defined fields shall indicate that no action is required by the field. In addition, codes not assigned within the fields shall indicate that no action is required.

*Note.*— *The provisions of 3.1.2.3.2.2 and 3.1.2.3.2.3 ensure that future assignments of previously unassigned coding space will not result in ambiguity. That is, Mode S equipment in which the new coding has not been implemented will clearly indicate that no information is being transmitted in newly assigned coding space.*

3.1.2.3.2.4 *Formats reserved for military use.* States shall ensure that uplink formats are only used for selectively addressed interrogations and that transmissions of uplink or downlink formats do not exceed the RF power, interrogation rate, reply rate and squitter rate requirements of Annex 10.

3.1.2.3.2.4.1 **Recommendation.**— *Through investigation and validation, States should ensure that military applications do not unduly affect the existing 1 030/1 090 MHz civil aviation operations environment.*

### 3.1.2.3.3 ERROR PROTECTION

3.1.2.3.3.1 *Technique.* Parity check coding shall be used within Mode S interrogations and replies to provide protection against the occurrence of errors.

3.1.2.3.3.1.1 *Parity check sequence.* A sequence of 24 parity check bits shall be generated by the rule described in 3.1.2.3.3.1.2 and shall be incorporated into the field formed by the last 24 bits of all Mode S transmissions. The 24 parity check bits shall be combined with either the address coding or the interrogator identifier coding as described in 3.1.2.3.3.2. The resulting combination then forms either the AP (address/parity, 3.1.2.3.2.1.3) field or the PI (parity/interrogator identifier, 3.1.2.3.2.1.4) field.

3.1.2.3.3.1.2 *Parity check sequence generation.* The sequence of 24 parity bits ( $p_1, p_2, \dots, p_{24}$ ) shall be generated from the sequence of information bits ( $m_1, m_2, \dots, m_k$ ) where  $k$  is 32 or 88 for short or long transmissions respectively. This shall be done by means of a code generated by the polynomial:

$$G(x) = 1 + x^3 + x^{10} + x^{12} + x^{13} + x^{14} + x^{15} + x^{16} \\ + x^{17} + x^{18} + x^{19} + x^{20} + x^{21} + x^{22} + x^{23} + x^{24}$$

When by the application of binary polynomial algebra,  $x^{24} [M(x)]$  is divided by  $G(x)$  where the information sequence  $M(x)$  is:

$$m_k + m_{k-1}x + m_{k-2}x^2 + \dots + m_1x^{k-1}$$

the result is a quotient and a remainder  $R(x)$  of degree less than 24. The bit sequence formed by this remainder represents the parity check sequence. Parity bit  $p_i$ , for any  $i$  from 1 to 24, is the coefficient of  $x^{24-i}$  in  $R(x)$ .

*Note.*— *The effect of multiplying  $M(x)$  by  $x^{24}$  is to append 24 ZERO bits to the end of the sequence.*

3.1.2.3.3.2 *AP and PI field generation.* Different address parity sequences shall be used for the uplink and downlink.

*Note.*— *The uplink sequence is appropriate for a transponder decoder implementation. The downlink sequence facilitates the use of error correction in downlink decoding.*

The code used in uplink AP field generation shall be formed as specified below from either the aircraft address (3.1.2.4.1.2.3.1.1), the all-call address (3.1.2.4.1.2.3.1.2) or the broadcast address (3.1.2.4.1.2.3.1.3).

The code used in downlink AP field generation shall be formed directly from the sequence of 24 Mode S address bits ( $a_1, a_2, \dots, a_{24}$ ), where  $a_i$  is the  $i$ -th bit transmitted in the aircraft address (AA) field of an all-call reply (3.1.2.5.2.2.2).

The code used in downlink PI field generation shall be formed by a sequence of 24 bits ( $a_1, a_2, \dots, a_{24}$ ), where the first 17 bits are ZEROs, the next three bits are a replica of the code label (CL) field (3.1.2.5.2.1.3) and the last four bits are a replica of the interrogator code (IC) field (3.1.2.5.2.1.2).

*Note.*— The PI code is not used in uplink transmissions.

A modified sequence ( $b_1, b_2, \dots, b_{24}$ ) shall be used for uplink AP field generation. Bit  $b_i$  is the coefficient of  $x^{48-i}$  in the polynomial  $G(x)A(x)$ , where:

$$A(x) = a_1x^{23} + a_2x^{22} + \dots + a_{24}$$

and  $G(x)$  is as defined in 3.1.2.3.3.1.2.

In the aircraft address  $a_i$  shall be the  $i$ -th bit transmitted in the AA field of an all-call reply. In the all-call and broadcast addresses  $a_i$  shall equal 1 for all values of  $i$ .

3.1.2.3.3.2.1 *Uplink transmission order.* The sequence of bits transmitted in the uplink AP field is:

$$t_{k+1}, t_{k+2}, \dots, t_{k+24}$$

where the bits are numbered in order of transmission, starting with  $k + 1$ .

In uplink transmissions:

$$t_{k+i} = b_i \oplus p_i$$

where “ $\oplus$ ” prescribes modulo-2 addition:  $i$  equals 1 is the first bit transmitted in the AP field.

3.1.2.3.3.2.2 *Downlink transmission order.* The sequence of bits transmitted in the downlink AP and PI field is:

$$t_{k+1}, t_{k+2}, \dots, t_{k+24}$$

where the bits are numbered in order of transmission, starting with  $k + 1$ . In downlink transmissions:

$$t_{k+i} = a_i \oplus p_i$$

where “ $\oplus$ ” prescribes modulo-2 addition:  $i$  equals 1 is the first bit transmitted in the AP or PI field.

### 3.1.2.4 GENERAL INTERROGATION-REPLY PROTOCOL

3.1.2.4.1 *Transponder transaction cycle.* A transponder transaction cycle shall begin when the SSR Mode S transponder has recognized an interrogation. The transponder shall then evaluate the interrogation and determine whether it shall be accepted. If accepted, it shall then process the received interrogation and generate a reply, if appropriate. The transaction cycle shall end when:

- a) any one of the necessary conditions for acceptance has not been met, or

- b) an interrogation has been accepted and the transponder has either:
  - 1) completed the processing of the accepted interrogation if no reply is required, or
  - 2) completed the transmission of a reply.

A new transponder transaction cycle shall not begin until the previous cycle has ended.

3.1.2.4.1.1 *Interrogation recognition.* SSR Mode S transponders shall be capable of recognizing the following distinct types of interrogations:

- a) Modes A and C;
- b) intermode; and
- c) Mode S.

*Note.*— *The recognition process is dependent upon the signal input level and the specified dynamic range (3.1.2.10.1).*

3.1.2.4.1.1.1 *Mode A and Mode C interrogation recognition.* A Mode A or Mode C interrogation shall be recognized when a  $P_1 - P_3$  pulse pair meeting the requirements of 3.1.1.4 has been received, and the leading edge of a  $P_4$  pulse with an amplitude that is greater than a level 6 dB below the amplitude of  $P_3$  is not received within the interval from 1.7 to 2.3 microseconds following the leading edge of  $P_3$ .

If a  $P_1 - P_2$  suppression pair and a Mode A or Mode C interrogation are recognized simultaneously, the transponder shall be suppressed. An interrogation shall not be recognized as Mode A or Mode C if the transponder is in suppression (3.1.2.4.2). If a Mode A and a Mode C interrogation are recognized simultaneously the transponder shall complete the transaction cycle as if only a Mode C interrogation had been recognized.

3.1.2.4.1.1.2 *Intermode interrogation recognition.* An intermode interrogation shall be recognized when a  $P_1 - P_3 - P_4$  pulse triplet meeting the requirements of 3.1.2.1.5.1 is received. An interrogation shall not be recognized as an intermode interrogation if:

- a) the received amplitude of the pulse in the  $P_4$  position is smaller than 6 dB below the amplitude of  $P_3$ ; or
- b) the pulse interval between  $P_3$  and  $P_4$  is larger than 2.3 microseconds or shorter than 1.7 microseconds; or
- c) the received amplitude of  $P_1$  and  $P_3$  is between MTL and  $-45$  dBm and the pulse duration of  $P_1$  or  $P_3$  is less than 0.3 microsecond; or
- d) the transponder is in suppression (3.1.2.4.2).

If a  $P_1 - P_2$  suppression pair and a Mode A or Mode C intermode interrogation are recognized simultaneously the transponder shall be suppressed.

3.1.2.4.1.1.3 *Mode S interrogation recognition.* A Mode S interrogation shall be recognized when a  $P_6$  pulse is received with a sync phase reversal within the interval from 1.20 to 1.30 microseconds following the leading edge of  $P_6$ . A Mode S interrogation shall not be recognized if a sync phase reversal is not received within the interval from 1.05 to 1.45 microseconds following the leading edge of  $P_6$ .

3.1.2.4.1.2 *Interrogation acceptance.* Recognition according to 3.1.2.4.1 shall be a prerequisite for acceptance of any interrogation.

3.1.2.4.1.2.1 *Mode A and Mode C interrogation acceptance.* Mode A and Mode C interrogations shall be accepted when recognized (3.1.2.4.1.1.1).

3.1.2.4.1.2.2 *Intermode interrogation acceptance*

3.1.2.4.1.2.2.1 *Mode A/C/S all-call interrogation acceptance.* A Mode A/C/S all-call interrogation shall be accepted if the trailing edge of  $P_4$  is received within 3.45 to 3.75 microseconds following the leading edge of  $P_3$  and no lockout condition (3.1.2.6.9) prevents acceptance. A Mode A/C/S all-call shall not be accepted if the trailing edge of  $P_4$  is received earlier than 3.3 or later than 4.2 microseconds following the leading edge of  $P_3$ , or if a lockout condition (3.1.2.6.9) prevents acceptance.

3.1.2.4.1.2.2.2 *Mode A/C-only all-call interrogation acceptance.* A Mode A/C-only all-call interrogation shall not be accepted by a Mode S transponder.

*Note.*— The technical condition for non-acceptance of a Mode A/C-only all-call is given in the preceding paragraph by the requirement for rejecting an intermode interrogation with a  $P_4$  pulse having a trailing edge following the leading edge of  $P_3$  by less than 3.3 microseconds.

3.1.2.4.1.2.3 *Mode S interrogation acceptance.* A Mode S interrogation shall only be accepted if:

- a) the transponder is capable of processing the uplink format (UF) of the interrogation (3.1.2.3.2.1.1);
- b) the address of the interrogation matches one of the addresses as defined in 3.1.2.4.1.2.3.1 implying that parity is established, as defined in 3.1.2.3.3;
- c) in the case of an all-call interrogation, no all-call lockout condition applies, as defined in 3.1.2.6.9; and
- d) the transponder is capable of processing the uplinked data of a long air-air surveillance (ACAS) interrogation (UF-16) and presenting it at an output interface as prescribed in 3.1.2.10.5.2.2.1.

*Note.*— A Mode S interrogation may be accepted if the conditions specified in 3.1.2.4.1.2.3 a) and b) are met and the transponder is not capable of both processing the uplinked data of a Comm-A interrogation (UF=20 and 21) and presenting it at an output interface as prescribed in 3.1.2.10.5.2.2.1.

3.1.2.4.1.2.3.1 *Addresses.* Mode S interrogations shall contain either:

- a) aircraft address; or
- b) the all-call address; or
- c) the broadcast address.

3.1.2.4.1.2.3.1.1 *Aircraft address.* If the aircraft's address is identical to the address extracted from a received interrogation according to the procedure of 3.1.2.3.3.2 and 3.1.2.3.3.2.1, the extracted address shall be considered correct for purposes of Mode S interrogation acceptance.

3.1.2.4.1.2.3.1.2 *All-call address.* A Mode S-only all-call interrogation (uplink format UF = 11) shall contain an address, designated the all-call address, consisting of twenty-four consecutive ONES. If the all-call address is extracted from a received interrogation with format UF = 11 according to the procedure of 3.1.2.3.3.2 and 3.1.2.3.3.2.1, the address shall be considered correct for Mode S-only all-call interrogation acceptance.

3.1.2.4.1.2.3.1.3 *Broadcast address.* To broadcast a message to all Mode S transponders within the interrogator beam, a Mode S interrogation uplink format 20 or 21 shall be used and an address of twenty-four consecutive ONEs shall be substituted for the aircraft address. If the UF code is 20 or 21 and this broadcast address is extracted from a received interrogation according to the procedure of 3.1.2.3.3.2 and 3.1.2.3.3.2.1, the address shall be considered correct for Mode S broadcast interrogation acceptance.

*Note.*— Transponders associated with airborne collision avoidance systems also accept a broadcast with  $UF = 16$ .

3.1.2.4.1.3 *Transponder replies.* Mode S transponders shall transmit the following reply types:

- a) Mode A and Mode C replies; and
- b) Mode S replies.

3.1.2.4.1.3.1 *Mode A and Mode C replies.* A Mode A (Mode C) reply shall be transmitted as specified in 3.1.1.6 when a Mode A (Mode C) interrogation has been accepted.

3.1.2.4.1.3.2 *Mode S replies.* Replies to other than Mode A and Mode C interrogations shall be Mode S replies.

3.1.2.4.1.3.2.1 *Replies to intermode interrogations.* A Mode S reply with downlink format 11 shall be transmitted in accordance with the provisions of 3.1.2.5.2.2 when a Mode A/C/S all-call interrogation has been accepted.

*Note.*— Since Mode S transponders do not accept Mode A/C-only all-call interrogations, no reply is generated.

3.1.2.4.1.3.2.2 *Replies to Mode S interrogations.* The information content of a Mode S reply shall reflect the conditions existing in the transponder after completion of all processing of the interrogation eliciting that reply. The correspondence between uplink and downlink formats shall be as summarized in Table 3-5.

*Note.*— Four categories of Mode S replies may be transmitted in response to Mode S interrogations:

- a) Mode S all-call replies ( $DF = 11$ );
- b) surveillance and standard-length communications replies ( $DF = 4, 5, 20$  and  $21$ );
- c) extended length communications replies ( $DF = 24$ ); and
- d) air-air surveillance replies ( $DF = 0$  and  $16$ ).

3.1.2.4.1.3.2.2.1 *Replies to SSR Mode S-only all-call interrogations.* The downlink format of the reply to a Mode S-only all-call interrogation (if required) shall be  $DF = 11$ . The reply content and rules for determining the requirement to reply shall be as defined in 3.1.2.5.

*Note.*— A Mode S reply may or may not be transmitted when a Mode S interrogation with  $UF = 11$  has been accepted.

3.1.2.4.1.3.2.2.2 *Replies to surveillance and standard length communications interrogations.* A Mode S reply shall be transmitted when a Mode S interrogation with  $UF = 4, 5, 20$  or  $21$  and an aircraft address has been accepted. The contents of these interrogations and replies shall be as defined in 3.1.2.6.

*Note.*— If a Mode S interrogation with  $UF = 20$  or  $21$  and a broadcast address is accepted, no reply is transmitted (3.1.2.4.1.2.3.1.3).

3.1.2.4.1.3.2.2.3 *Replies to extended length communications interrogations.* A series of Mode S replies ranging in number from 0 to 16 shall be transmitted when a Mode S interrogation with  $UF = 24$  has been accepted. The downlink format of the reply (if any) shall be  $DF = 24$ . Protocols defining the number and content of the replies shall be as defined in 3.1.2.7.

3.1.2.4.1.3.2.2.4 *Replies to air-air surveillance interrogations.* A Mode S reply shall be transmitted when a Mode S interrogation with UF = 0 and an aircraft address has been accepted. The contents of these interrogations and replies shall be as defined in 3.1.2.8.

### 3.1.2.4.2 SUPPRESSION

3.1.2.4.2.1 *Effects of suppression.* A transponder in suppression (3.1.1.7.4) shall not recognize Mode A, Mode C or intermode interrogations if either the  $P_1$  pulse alone or both the  $P_1$  and  $P_3$  pulses of the interrogation are received during the suppression interval. Suppression shall not affect the recognition of, acceptance of, or replies to Mode S interrogations.

3.1.2.4.2.2 *Suppression pairs.* The two-pulse Mode A/C suppression pair defined in 3.1.1.7.4.1 shall initiate suppression in a Mode S transponder regardless of the position of the pulse pair in a group of pulses, provided the transponder is not already suppressed or in a transaction cycle.

*Note.— The  $P_3 - P_4$  pair of the Mode A/C-only all-call interrogation both prevents a reply and initiates suppression. Likewise, the  $P_1 - P_2$  preamble of a Mode S interrogation initiates suppression independently of the waveform that follows it.*

3.1.2.4.2.3 Suppression in presence of  $S_1$  pulse shall be as defined in 3.1.1.7.4.3.

## 3.1.2.5 INTERMODE AND MODE S ALL-CALL TRANSACTIONS

### 3.1.2.5.1 INTERMODE TRANSACTIONS

*Note.— Intermode transactions permit the surveillance of Mode A/C-only aircraft and the acquisition of Mode S aircraft. The Mode A/C/S all-call interrogation allows Mode A/C-only and Mode S transponders to be interrogated by the same transmissions. The Mode A/C-only all-call interrogation makes it possible to elicit replies only from Mode A/C transponders. In multisite scenarios, the interrogator must transmit its identifier code in the Mode S only all-call interrogation. Thus, a pair of Mode S-only and Mode A/C-only all-call interrogations are used. The intermode interrogations are defined in 3.1.2.1.5.1 and the corresponding interrogation-reply protocols are defined in 3.1.2.4.*

### 3.1.2.5.2 MODE S-ONLY ALL-CALL TRANSACTIONS

*Note.— These transactions allow the ground to acquire Mode S aircraft by use of an interrogation addressed to all Mode S-equipped aircraft. The reply is via downlink format 11 which returns the aircraft address. The interrogation-reply protocols are defined in 3.1.2.4.*

#### 3.1.2.5.2.1 Mode S-only all-call interrogation, uplink format 11

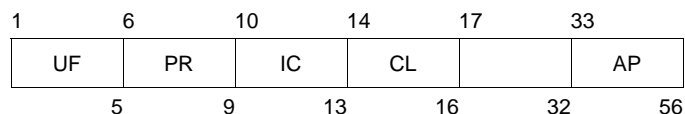



The format of this interrogation shall consist of these fields:

<i>Field</i>	<i>Reference</i>
UF uplink format	3.1.2.3.2.1.1
PR probability of reply	3.1.2.5.2.1.1
IC interrogator code	3.1.2.5.2.1.2
CL code label	3.1.2.5.2.1.3
spare — 16 bits	
AP address/parity	3.1.2.3.2.1.3

3.1.2.5.2.1.1 *PR: Probability of reply.* This 4-bit (6-9) uplink field shall contain commands to the transponder specifying the probability of reply to that interrogation (3.1.2.5.4). Codes are as follows:

0	signifies reply with probability of 1
1	signifies reply with probability of 1/2
2	signifies reply with probability of 1/4
3	signifies reply with probability of 1/8
4	signifies reply with probability of 1/16
5, 6, 7	not assigned
8	signifies disregard lockout, reply with probability of 1
9	signifies disregard lockout, reply with probability of 1/2
10	signifies disregard lockout, reply with probability of 1/4
11	signifies disregard lockout, reply with probability of 1/8
12	signifies disregard lockout, reply with probability of 1/16
13, 14, 15	not assigned.

3.1.2.5.2.1.2 *IC: Interrogator code.* This 4-bit (10-13) uplink field shall contain either the 4-bit interrogator identifier code (3.1.2.5.2.1.2.3) or the lower 4 bits of the 6-bit surveillance identifier code (3.1.2.5.2.1.2.4) depending on the value of the CL field (3.1.2.5.2.1.3).

3.1.2.5.2.1.2.1 **Recommendation.**— *It is recommended that whenever possible an interrogator should operate using a single interrogator code.*

3.1.2.5.2.1.2.2 *The use of multiple interrogator codes by one interrogator.* An interrogator shall not interleave Mode S-only all-call interrogations using different interrogator codes.

*Note.*— *An explanation of RF interference issues, sector size and impact on data link transactions is presented in the Aeronautical Surveillance Manual (Doc 9924).*

3.1.2.5.2.1.2.3 *II: Interrogator identifier.* This 4-bit value shall define an interrogator identifier (II) code. These II codes shall be assigned to interrogators in the range from 0 to 15. The II code value of 0 shall only be used for supplementary acquisition in conjunction with acquisition based on lockout override (3.1.2.5.2.1.4 and 3.1.2.5.2.1.5). When two II codes are assigned to one interrogator only, one II code shall be used for full data link purposes.

*Note.*— *Limited data link activity including single segment Comm-A, uplink and downlink broadcast protocols and GICB extraction may be performed by both II codes.*

3.1.2.5.2.1.2.4 *SI: Surveillance identifier.* This 6-bit value shall define a surveillance identifier (SI) code. These SI codes shall be assigned to interrogators in the range from 1 to 63. The SI code value of 0 shall not be used. The SI codes shall be used with the multisite lockout protocols (3.1.2.6.9.1). The SI codes shall not be used with the multisite communications protocols (3.1.2.6.11.3.2, 3.1.2.7.4 or 3.1.2.7.7).

3.1.2.5.2.1.3 *CL: Code label.* This 3-bit (14-16) uplink field shall define the contents of the IC field.

*Coding (in binary)*

000	signifies that the IC field contains the II code
001	signifies that the IC field contains SI codes 1 to 15
010	signifies that the IC field contains SI codes 16 to 31
011	signifies that the IC field contains SI codes 32 to 47
100	signifies that the IC field contains SI codes 48 to 63

The other values of the CL field shall not be used.

3.1.2.5.2.1.3.1 *Surveillance identifier (SI) code capability report.* Transponders which process the SI codes (3.1.2.5.2.1.2.4) shall report this capability by setting bit 35 to 1 in the surveillance identifier capability (SIC) subfield of the MB field of the data link capability report (3.1.2.6.10.2.2).

3.1.2.5.2.1.4 *Operation based on lockout override*

*Note 1.— The Mode S-only all-call lockout override provides the basis for acquisition of Mode S aircraft for interrogators that have not been assigned a unique IC (II or SI code) for full Mode S operation (protected acquisition by ensuring that no other interrogator on the same IC can lock out the target in the same coverage area).*

*Note 2.— Lockout override is possible using any interrogator code.*

3.1.2.5.2.1.4.1 *Maximum Mode S-only all-call interrogation rate.* The maximum rate of Mode S-only all-call interrogations made by an interrogator using acquisition based on lockout override shall depend on the reply probability as follows:

- a) for a reply probability equal to 1.0:  
the smaller of 3 interrogations per 3 dB beam dwell or 30 interrogations per second;
- b) for a reply probability equal to 0.5:  
the smaller of 5 interrogations per 3 dB beam dwell or 60 interrogations per second; and
- c) for a reply probability equal to 0.25 or less:  
the smaller of 10 interrogations per 3 dB beam dwell or 125 interrogations per second.

*Note.— These limits have been defined in order to minimize the RF pollution generated by such a method while keeping a minimum of replies to allow acquisition of aircraft within a beam dwell.*

3.1.2.5.2.1.4.2 *Field content for a selectively addressed interrogation used by an interrogator without an assigned interrogator code.* An interrogator that has not been assigned with a unique discrete interrogator code and is authorized to transmit shall use the II code 0 to perform the selective interrogations. In this case, selectively addressed interrogations used in connection with acquisition using lockout override shall have interrogation field contents restricted as follows:

UF = 4, 5, 20 or 21  
 PC = 0  
 RR  $\neq$  16 if RRS = 0  
 DI = 7  
 IIS = 0  
 LOS = 0 except as specified in 3.1.2.5.2.1.5  
 TMS = 0

*Note.*— These restrictions permit surveillance and GICB transactions, but prevent the interrogation from making any changes to transponder multisite lockout or communications protocol states.

#### 3.1.2.5.2.1.5 Supplementary acquisition using II equals 0

*Note 1.*— The acquisition technique defined in 3.1.2.5.2.1.4 provides rapid acquisition for most aircraft. Due to the probabilistic nature of the process, it may take many interrogations to acquire the last aircraft of a large set of aircraft in the same beam dwell and near the same range (termed a local garble zone). Acquisition performance is greatly improved for the acquisition of these aircraft through the use of limited selective lockout using II equals 0.

*Note 2.*— Supplementary acquisition consists of locking out acquired aircraft to II=0 followed by acquisition by means of the Mode S-only all-call interrogation with II=0. Only the aircraft not yet acquired and not yet locked-out will reply resulting in an easier acquisition.

##### 3.1.2.5.2.1.5.1 Lockout within a beam dwell

3.1.2.5.2.1.5.1.1 **Recommendation.**— When II equals 0 lockout is used to supplement acquisition, all aircraft within the beam dwell of the aircraft being acquired should be commanded to lock out to II equals 0, not just those in the garble zone.

*Note.*— Lockout of all aircraft in the beam dwell will reduce the amount of all-call fruit replies generated to the II equals 0 all-call interrogations.

##### 3.1.2.5.2.1.5.2 Duration of lockout

3.1.2.5.2.1.5.2.1 Interrogators performing supplementary acquisition using II equals 0 shall perform acquisition by transmitting a lockout command for no more than two consecutive scans to each of the aircraft already acquired in the beam dwell containing the garble zone and shall not repeat it before 48 seconds have elapsed.

*Note.*— Minimizing the lockout time reduces the probability of conflict with the acquisition activities of a neighbouring interrogator that is also using II equals 0 for supplementary acquisition.

3.1.2.5.2.1.5.2.2 **Recommendation.**— Mode S only all-call interrogations with II=0 for the purpose of supplementary acquisition should take place within a garble zone over no more than two consecutive scans or a maximum of 18 seconds.

#### 3.1.2.5.2.2 All-call reply, downlink format 11

1	6	9	33
DF	CA	AA	PI
5	8	32	56

The reply to the Mode S-only all-call or the Mode A/C/S all-call interrogation shall be the Mode S all-call reply, downlink format 11. The format of this reply shall consist of these fields:

<i>Field</i>	<i>Reference</i>
DF downlink format	3.1.2.3.2.1.2
CA capability	3.1.2.5.2.2.1
AA address announced	3.1.2.5.2.2.2
PI parity/interrogator identifier	3.1.2.3.2.1.4

3.1.2.5.2.2.1 *CA: Capability.* This 3-bit (6-8) downlink field shall convey information on the transponder level, the additional information below, and shall be used in formats DF = 11 and DF = 17.

#### *Coding*

- 0 signifies Level 1 transponder (surveillance only), and no ability to set CA code 7 and either airborne or on the ground
- 1 reserved
- 2 reserved
- 3 reserved
- 4 signifies Level 2 or above transponder and ability to set CA code 7 and on the ground
- 5 signifies Level 2 or above transponder and ability to set CA code 7 and airborne
- 6 signifies Level 2 or above transponder and ability to set CA code 7 and either airborne or on the ground
- 7 signifies the DR field is not equal to 0 or the FS field equals 2, 3, 4 or 5, and either airborne or on the ground

When the conditions for CA code 7 are not satisfied, aircraft with Level 2 or above transponders:

- a) that do not have automatic means to set the on-the-ground condition shall use CA code 6;
- b) with automatic on-the-ground determination shall use CA code 4 when on the ground and 5 when airborne; and
- c) with or without automatic on-the-ground determination shall use CA = 4 when commanded to set and report the on-the-ground status via the TCS subfield (3.1.2.6.1.4.1 f)).

Data link capability reports (3.1.2.6.10.2.2) shall be available from aircraft installations that set CA code 4, 5, 6 or 7.

*Note.*— CA codes 1 to 3 are reserved to maintain backward compatibility.

3.1.2.5.2.2.2 *AA: Address announced.* This 24-bit (9-32) downlink field shall contain the aircraft address which provides unambiguous identification of the aircraft.

3.1.2.5.3 *Lockout protocol.* The all-call lockout protocol defined in 3.1.2.6.9 shall be used by the interrogator with respect to an aircraft once the address of that specific aircraft has been acquired by an interrogator provided that:

- the interrogator is using an IC code different from zero; and
- the aircraft is located in an area where the interrogator is authorized to use lockout.

*Note 1.*— Following acquisition, a transponder is interrogated by discretely addressed interrogations as prescribed in 3.1.2.6, 3.1.2.7 and 3.1.2.8 and the all-call lockout protocol is used to inhibit replies to further all-call interrogations.

*Note 2.*— Regional IC allocation bodies may define rules limiting the use of selective interrogation and lockout protocol (e.g. no lockout in defined limited area, use of intermittent lockout in defined areas, and no lockout of aircraft not yet equipped with SI code capability).

3.1.2.5.4 *Stochastic all-call protocol.* The transponder shall execute a random process upon acceptance of a Mode S-only all-call with a PR code equal to 1 to 4 or 9 to 12. A decision to reply shall be made in accordance with the probability specified in the interrogation. A transponder shall not reply if a PR code equal to 5, 6, 7, 13, 14 or 15 is received (3.1.2.5.2.1.1).

*Note.*— *The random occurrence of replies makes it possible for the interrogator to acquire closely spaced aircraft, replies from which would otherwise synchronously garble each other.*

### 3.1.2.6 ADDRESSED SURVEILLANCE AND STANDARD LENGTH COMMUNICATION TRANSACTIONS

*Note 1.*— *The interrogations described in this section are addressed to specific aircraft. There are two basic interrogation and reply types, short and long. The short interrogations and replies are UF 4 and 5 and DF 4 and 5, while the long interrogations and replies are UF 20 and 21 and DF 20 and 21.*

*Note 2.*— *The communications protocols are given in 3.1.2.6.11. These protocols describe the control of the data exchange.*

#### 3.1.2.6.1 SURVEILLANCE, ALTITUDE REQUEST, UPLINK FORMAT 4

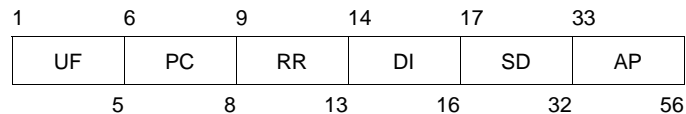

The format of this interrogation shall consist of these fields:

<i>Field</i>	<i>Reference</i>
UF uplink format	3.1.2.3.2.1.1
PC protocol	3.1.2.6.1.1
RR reply request	3.1.2.6.1.2
DI designator identification	3.1.2.6.1.3
SD special designator	3.1.2.6.1.4
AP address/parity	3.1.2.3.2.1.3

3.1.2.6.1.1 *PC: Protocol.* This 3-bit, (6-8) uplink field shall contain operating commands to the transponder. The PC field shall be ignored for the processing of surveillance or Comm-A interrogations containing DI = 3 (3.1.2.6.1.4.1).

#### *Coding*

- 0 signifies no action
- 1 signifies non-selective all-call lockout (3.1.2.6.9.2)
- 2 not assigned
- 3 not assigned
- 4 signifies close out Comm-B (3.1.2.6.11.3.2.3)
- 5 signifies close out uplink ELM (3.1.2.7.4.2.8)
- 6 signifies close out downlink ELM (3.1.2.7.7.3)
- 7 not assigned.

3.1.2.6.1.2 *RR: Reply request.* This 5-bit, (9-13) uplink field shall command the length and content of a requested reply.

The last four bits of the 5-bit RR code, transformed into their decimal equivalent, shall designate the BDS1 code (3.1.2.6.11.2 or 3.1.2.6.11.3) of the requested Comm-B message if the most significant bit (MSB) of the RR code is 1 (RR is equal to or greater than 16).

*Coding*

- RR = 0-15 shall be used to request a reply with surveillance format (DF = 4 or 5);
- RR = 16-31 shall be used to request a reply with Comm-B format (DF = 20 or 21);
- RR = 16 shall be used to request transmission of an air-initiated Comm-B according to 3.1.2.6.11.3;
- RR = 17 shall be used to request a data link capability report according to 3.1.2.6.10.2.2;
- RR = 18 shall be used to request aircraft identification according to 3.1.2.9;
- 19-31 are not assigned in section 3.1.

*Note.— Codes 19-31 are reserved for applications such as data link communications, airborne collision avoidance systems (ACAS), etc.*

3.1.2.6.1.3 *DI: Designator identification.* This 3-bit (14-16) uplink field shall identify the structure of the SD field (3.1.2.6.1.4).

*Coding*

- 0 signifies SD not assigned except for IIS
- 1 signifies SD contains multisite and communications control information
- 2 signifies SD contains control data for extended squitter
- 3 signifies SD contains SI multisite lockout, broadcast and GICB control information
- 4-6 signifies SD not assigned
- 7 signifies SD contains extended data readout request, multisite and communications control information.

3.1.2.6.1.4 *SD: Special designator.* This 16-bit (17-32) uplink field shall contain control codes which depend on the coding in the DI field.

*Note.— The special designator (SD) field is provided to accomplish the transfer of multisite, lockout and communications control information from the ground station to the transponder.*

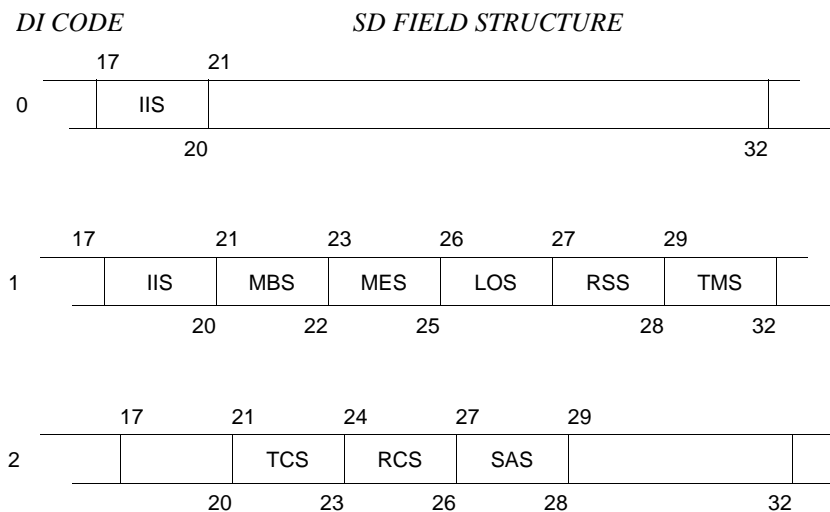

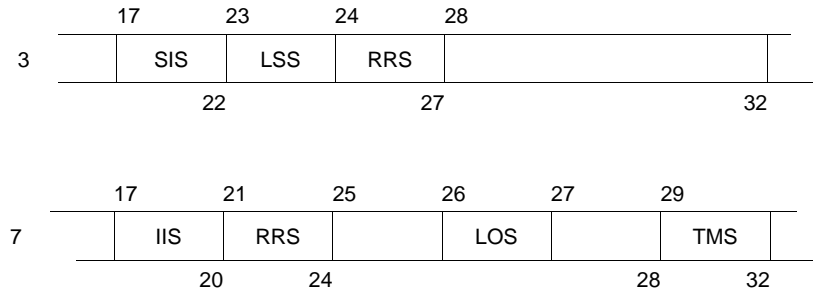

3.1.2.6.1.4.1 *Subfields in SD.* The SD field shall contain information as follows:

a) If DI = 0, 1 or 7:

IIS, the 4-bit (17-20) interrogator identifier subfield shall contain an assigned identifier code of the interrogator (3.1.2.5.2.1.2.3).

b) If DI = 0:

bits 21-32 are not assigned.

c) If DI = 1:

MBS, the 2-bit (21, 22) multisite Comm-B subfield shall have the following codes:

- 0 signifies no Comm-B action
- 1 signifies air-initiated Comm-B reservation request (3.1.2.6.11.3.1)
- 2 signifies Comm-B closeout (3.1.2.6.11.3.2.3)
- 3 not assigned.

MES, the 3-bit (23-25) multisite ELM subfield shall contain reservation and closeout commands for ELM as follows:

- 0 signifies no ELM action
- 1 signifies uplink ELM reservation request (3.1.2.7.4.1)
- 2 signifies uplink ELM closeout (3.1.2.7.4.2.8)
- 3 signifies downlink ELM reservation request (3.1.2.7.7.1.1)
- 4 signifies downlink ELM closeout (3.1.2.7.7.3)
- 5 signifies uplink ELM reservation request and downlink ELM closeout
- 6 signifies uplink ELM closeout and downlink ELM reservation request
- 7 signifies uplink ELM and downlink ELM closeouts.

RSS, the 2-bit (27, 28) reservation status subfield shall request the transponder to report its reservation status in the UM field. The following codes have been assigned:

- 0 signifies no request
- 1 signifies report Comm-B reservation status in UM
- 2 signifies report uplink ELM reservation status in UM
- 3 signifies report downlink ELM reservation status in UM.

## d) If DI = 1 or 7:

LOS, the 1-bit (26) lockout subfield, if set to 1, shall signify a multisite lockout command from the interrogator indicated in IIS. LOS set to 0, shall be used to signify that no change in lockout state is commanded.

TMS, the 4-bit (29-32) tactical message subfield shall contain communications control information used by the data link avionics.

## e) If DI = 7:

RRS, the 4-bit (21-24) reply request subfield in SD shall give the BDS2 code of a requested Comm-B reply.

Bits 25, 27 and 28 are not assigned.

## f) If DI = 2:

TCS, the 3-bit (21-23) type control subfield in SD shall control the on-the-ground status reported by the transponder. The following codes have been assigned:

- 0 signifies no on-the-ground status command
- 1 signifies set and report the on-the-ground status for the next 15 seconds
- 2 signifies set and report the on-the-ground status for the next 60 seconds
- 3 signifies cancel the on-the-ground command
- 4-7 not assigned.

The transponder shall be able to accept a new command to set or cancel the on-the-ground status even though a prior command has not as yet timed out.

*Note.— Cancellation of the on-the-ground status command signifies that the determination of the vertical status reverts to the aircraft technique for this purpose. It does not signify a command to change to the vertical status.*

RCS, the 3-bit (24-26) rate control subfield in SD shall control the squitter rate of the transponder when it is reporting the surface format. This subfield shall have no effect on the transponder squitter rate when it is reporting the airborne position type. The following codes have been assigned:

- 0 signifies no surface position extended squitter rate command
- 1 signifies report high surface position extended squitter rate for 60 seconds
- 2 signifies report low surface position extended squitter rate for 60 seconds
- 3 signifies suppress all surface position extended squitters for 60 seconds
- 4 signifies suppress all surface position extended squitters for 120 seconds
- 5-7 not assigned.

*Note 1.— The definition of high and low squitter rates is given in 3.1.2.8.6.4.3.*

*Note 2.— As stated in 3.1.2.8.5.2 d), acquisition squitters are transmitted when surface position extended squitters are suppressed by using RCS=3 or 4.*

SAS, the 2-bit (27-28) surface antenna subfield in SD shall control the selection of the transponder diversity antenna that is used for (1) the extended squitter when the transponder is reporting the surface format, and (2) the acquisition squitter when the transponder is reporting the on-the-ground status. This subfield shall have no effect on the transponder diversity antenna selection when it is reporting the airborne status. The following codes have been assigned:



- 0 signifies no antenna command
- 1 signifies alternate top and bottom antennas for 120 seconds
- 2 signifies use bottom antenna for 120 seconds
- 3 signifies return to the default.

*Note.*— The top antenna is the default condition (3.1.2.8.6.5).

g) If DI = 3:

SIS, the 6-bit (17-22) surveillance identifier subfield in SD shall contain an assigned surveillance identifier code of the interrogator (3.1.2.5.2.1.2.4).

LSS, the 1-bit (23) lockout surveillance subfield, if set to 1, shall signify a multisite lockout command from the interrogator indicated in SIS. If set to 0, LSS shall signify that no change in lockout state is commanded.

RRS, the 4-bit (24-27) reply request subfield in SD shall contain the BDS2 code of a requested GICB register.

Bits 28 to 32 are not assigned.

3.1.2.6.1.5 *PC and SD field processing.* When DI = 1, PC field processing shall be completed before processing the SD field.

#### 3.1.2.6.2 *COMM-A ALTITUDE REQUEST, UPLINK FORMAT 20*

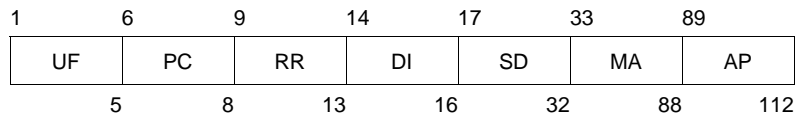

The format of this interrogation shall consist of these fields:

<i>Field</i>	<i>Reference</i>
UF uplink format	3.1.2.3.2.1.1
PC protocol	3.1.2.6.1.1
RR reply request	3.1.2.6.1.2
DI designator identification	3.1.2.6.1.3
SD special designator	3.1.2.6.1.4
MA message, Comm-A	3.1.2.6.2.1
AP address/parity	3.1.2.3.2.1.3

3.1.2.6.2.1 *MA: Message, Comm-A.* This 56-bit (33-88) field shall contain a data link message to the aircraft.

#### 3.1.2.6.3 *SURVEILLANCE IDENTITY REQUEST, UPLINK FORMAT 5*

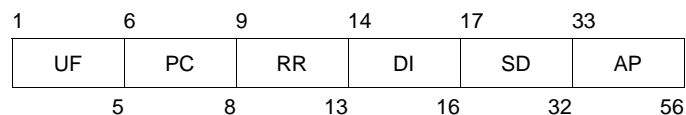

The format of this interrogation shall consist of these fields:

<i>Field</i>	<i>Reference</i>
UF uplink format	3.1.2.3.2.1.1
PC protocol	3.1.2.6.1.1
RR reply request	3.1.2.6.1.2
DI designator identification	3.1.2.6.1.3
SD special designator	3.1.2.6.1.4
AP address/parity	3.1.2.3.2.1.3

#### 3.1.2.6.4 COMM-A IDENTITY REQUEST, UPLINK FORMAT 21

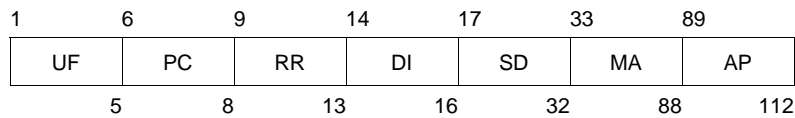

The format of this interrogation shall consist of these fields:

<i>Field</i>	<i>Reference</i>
UF uplink format	3.1.2.3.2.1.1
PC protocol	3.1.2.6.1.1
RR reply request	3.1.2.6.1.2
DI designator identification	3.1.2.6.1.3
SD special designator	3.1.2.6.1.4
MA message, Comm-A	3.1.2.6.2.1
AP address/parity	3.1.2.3.2.1.3

#### 3.1.2.6.5 SURVEILLANCE ALTITUDE REPLY, DOWNLINK FORMAT 4

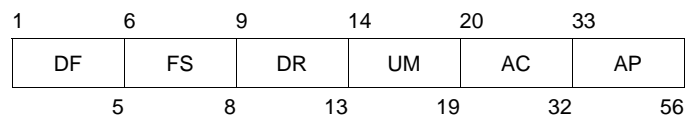

This reply shall be generated in response to an interrogation UF 4 or 20 with an RR field value less than 16. The format of this reply shall consist of these fields:

<i>Field</i>	<i>Reference</i>
DF downlink format	3.1.2.3.2.1.2
FS flight status	3.1.2.6.5.1
DR downlink request	3.1.2.6.5.2
UM utility message	3.1.2.6.5.3
AC altitude code	3.1.2.6.5.4
AP address/parity	3.1.2.3.2.1.3

3.1.2.6.5.1 *FS: Flight status.* This 3-bit (6-8) downlink field shall contain the following information:

*Coding*

- 0 signifies no alert and no SPI, aircraft is airborne
- 1 signifies no alert and no SPI, aircraft is on the ground
- 2 signifies alert, no SPI, aircraft is airborne
- 3 signifies alert, no SPI, aircraft is on the ground
- 4 signifies alert and SPI, aircraft is airborne or on the ground
- 5 signifies no alert and SPI, aircraft is airborne or on the ground
- 6 reserved
- 7 not assigned

*Note.*— The conditions which cause an alert are given in 3.1.2.6.10.1.1.

3.1.2.6.5.2 *DR: Downlink request.* This 5-bit (9-13) downlink field shall contain requests to downlink information.

*Coding*

- 0 signifies no downlink request
- 1 signifies request to send Comm-B message
- 2 reserved for ACAS
- 3 reserved for ACAS
- 4 signifies Comm-B broadcast message 1 available
- 5 signifies Comm-B broadcast message 2 available
- 6 reserved for ACAS
- 7 reserved for ACAS
- 8-15 not assigned
- 16-31 see downlink ELM protocol (3.1.2.7.7.1)

Codes 1-15 shall take precedence over codes 16-31.

*Note.*— Giving precedence to codes 1-15 permits the announcement of a Comm-B message to interrupt the announcement of a downlink ELM. This gives priority to the announcement of the shorter message.

3.1.2.6.5.3 *UM: Utility message.* This 6-bit (14-19) downlink field shall contain transponder communications status information as specified in 3.1.2.6.1.4.1 and 3.1.2.6.5.3.1.

3.1.2.6.5.3.1 Subfields in UM for multisite protocols

*UM FIELD STRUCTURE*

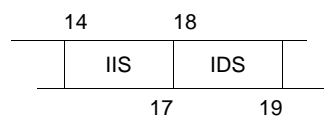

The following subfields shall be inserted by the transponder into the UM field of the reply if a surveillance or Comm-A interrogation (UF equals 4, 5, 20, 21) contains DI = 1 and RSS other than 0:

**IIS:** The 4-bit (14-17) interrogator identifier subfield reports the identifier of the interrogator that is reserved for multisite communications.

IDS: The 2-bit (18, 19) identifier designator subfield reports the type of reservation made by the interrogator identified in IIS.

Assigned coding is:

- 0 signifies no information
- 1 signifies IIS contains Comm-B II code
- 2 signifies IIS contains Comm-C II code
- 3 signifies IIS contains Comm-D II code.

3.1.2.6.5.3.2 *Multisite reservation status.* The interrogator identifier of the ground station currently reserved for multisite Comm-B delivery (3.1.2.6.11.3.1) shall be transmitted in the IIS subfield together with code 1 in the IDS subfield if the UM content is not specified by the interrogation (when DI = 0 or 7, or when DI = 1 and RSS = 0).

The interrogator identifier of the ground station currently reserved for downlink ELM delivery (3.1.2.7.6.1), if any, shall be transmitted in the IIS subfield together with code 3 in the IDS subfield if the UM content is not specified by the interrogation and there is no current Comm-B reservation.

3.1.2.6.5.4 *AC: Altitude code.* This 13-bit (20-32) field shall contain altitude coded as follows:

- a) Bit 26 is designated as the M bit, and shall be 0 if the altitude is reported in feet. M equals 1 shall be reserved to indicate that the altitude reporting is in metric units.
- b) If M equals 0, then bit 28 is designated as the Q bit. Q equals 0 shall be used to indicate that the altitude is reported in 100-foot increments. Q equals 1 shall be used to indicate that the altitude is reported in 25-foot increments.
- c) If the M bit (bit 26) and the Q bit (bit 28) equal 0, the altitude shall be coded according to the pattern for Mode C replies of 3.1.1.7.12.2.3. Starting with bit 20 the sequence shall be C1, A1, C2, A2, C4, A4, ZERO, B1, ZERO, B2, D2, B4, D4.
- d) If the M bit equals 0 and the Q bit equals 1, the 11-bit field represented by bits 20 to 25, 27 and 29 to 32 shall represent a binary coded field with a least significant bit (LSB) of 25 ft. The binary value of the positive decimal integer “N” shall be encoded to report pressure-altitude in the range [(25 N – 1 000) plus or minus 12.5 ft]. The coding of 3.1.2.6.5.4 c) shall be used to report pressure-altitude above 50 187.5 ft.

*Note 1.— This coding method is only able to provide values between minus 1 000 ft and plus 50 175 ft.*

*Note 2.— The most significant bit (MSB) of this field is bit 20 as required by 3.1.2.3.1.3.*

- e) If the M bit equals 1, the 12-bit field represented by bits 20 to 25 and 27 to 31 shall be reserved for encoding altitude in metric units.
- f) 0 shall be transmitted in each of the 13 bits of the AC field if altitude information is not available or if the altitude has been determined invalid.

### 3.1.2.6.6 COMM-B ALTITUDE REPLY, DOWNLINK FORMAT 20

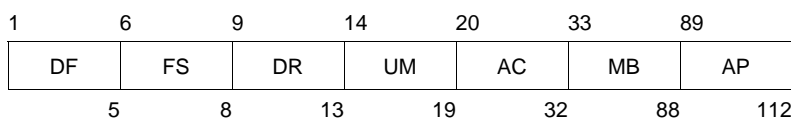

This reply shall be generated in response to an interrogation UF 4 or 20 with an RR field value greater than 15. The format of this reply shall consist of these fields:

<i>Field</i>	<i>Reference</i>
DF downlink format	3.1.2.3.2.1.2
FS flight status	3.1.2.6.5.1
DR downlink request	3.1.2.6.5.2
UM utility message	3.1.2.6.5.3
AC altitude code	3.1.2.6.5.4
MB message, Comm-B	3.1.2.6.6.1
AP address/parity	3.1.2.3.2.1.3

3.1.2.6.6.1 *MB: Message, Comm-B.* This 56-bit (33-88) downlink field shall be used to transmit data link messages to the ground.

#### 3.1.2.6.7 *SURVEILLANCE IDENTITY REPLY, DOWNLINK FORMAT 5*

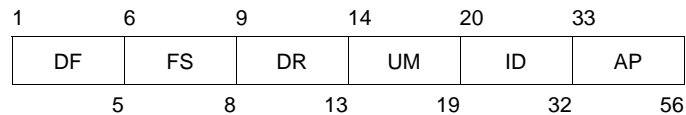

This reply shall be generated in response to an interrogation UF 5 or 21 with an RR field value less than 16. The format of this reply shall consist of these fields:

<i>Field</i>	<i>Reference</i>
DF downlink format	3.1.2.3.2.1.2
FS flight status	3.1.2.6.5.1
DR downlink request	3.1.2.6.5.2
UM utility message	3.1.2.6.5.3
ID identity	3.1.2.6.7.1
AP address/parity	3.1.2.3.2.1.3

3.1.2.6.7.1 *ID: Identity (Mode A code).* This 13-bit (20-32) field shall contain aircraft identity code, in accordance with the pattern for Mode A replies in 3.1.1.6. Starting with bit 20, the sequence shall be C1, A1, C2, A2, C4, A4, ZERO, B1, D1, B2, D2, B4, D4.

#### 3.1.2.6.8 *COMM-B IDENTITY REPLY, DOWNLINK FORMAT 21*

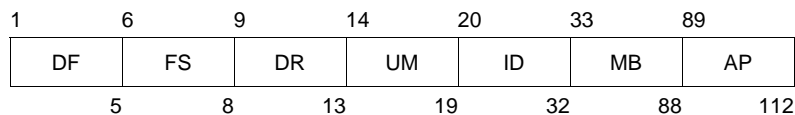

This reply shall be generated in response to an interrogation UF 5 or 21 with an RR field value greater than 15. The format of this reply shall consist of these fields:

<i>Field</i>	<i>Reference</i>
DF downlink format	3.1.2.3.2.1.2
FS flight status	3.1.2.6.5.1
DR downlink request	3.1.2.6.5.2
UM utility message	3.1.2.6.5.3
ID identity	3.1.2.6.7.1
MB message, Comm-B	3.1.2.6.6.1
AP address/parity	3.1.2.3.2.1.3

### 3.1.2.6.9 LOCKOUT PROTOCOLS

#### 3.1.2.6.9.1 Multisite all-call lockout

*Note.*— The multisite lockout protocol prevents transponder acquisition from being denied one ground station by lockout commands from an adjacent ground station that has overlapping coverage.

3.1.2.6.9.1.1 The multisite lockout command shall be transmitted in the SD field (3.1.2.6.1.4.1). A lockout command for an II code shall be transmitted in an SD with DI = 1 or DI = 7. An II lockout command shall be indicated by LOS code equals 1 and the presence of a non-zero interrogator identifier in the IIS subfield of SD. A lockout command for an SI code shall be transmitted in an SD with DI = 3. SI lockout shall be indicated by LSS equals 1 and the presence of a non-zero interrogator identifier in the SIS subfield of SD. After a transponder has accepted an interrogation containing a multisite lockout command, that transponder shall commence to lock out (i.e. not accept) any Mode S-only all-call interrogation which includes the identifier of the interrogator that commanded the lockout. The lockout shall persist for an interval  $T_L$  (3.1.2.10.3.9) after the last acceptance of an interrogation containing the multisite lockout command. Multisite lockout shall not prevent acceptance of a Mode S-only all-call interrogation containing PR codes 8 to 12. If a lockout command (LOS = 1) is received together with IIS = 0, it shall be interpreted as a non-selective all-call lockout (3.1.2.6.9.2).

*Note 1.*— Fifteen interrogators can send independent multisite II lockout commands. In addition, 63 interrogators can send independent SI lockout commands. Each of these lockout commands must be timed separately.

*Note 2.*— Multisite lockout (which only uses non-zero II codes) does not affect the response of the transponder to Mode S-only all-call interrogations containing II equals 0 or to Mode A/C/S all-call interrogations.

#### 3.1.2.6.9.2 Non-selective all-call lockout

*Note 1.*— In cases where the multisite lockout protocol for II codes is not required (e.g. there is no overlapping coverage or there is ground station coordination via ground-to-ground communications) the non-selective lockout protocol may be used.

On acceptance of an interrogation containing code 1 in the PC field, a transponder shall commence to lock out (i.e. not accept) two types of all-call interrogations:

- a) the Mode S-only all-call (UF = 11), with II equals 0; and
- b) the Mode A/C/S all-call of 3.1.2.1.5.1.1.

This lockout condition shall persist for an interval  $T_D$  (3.1.2.10.3.9) after the last receipt of the command. Non-selective lockout shall not prevent acceptance of a Mode S-only all-call interrogation containing PR codes 8 to 12.

*Note 2.*— Non-selective lockout does not affect the response of the transponder to Mode S-only all-call interrogations containing II not equal to 0.

## 3.1.2.6.10 BASIC DATA PROTOCOLS

3.1.2.6.10.1 *Flight status protocol.* Flight status shall be reported in the FS field (3.1.2.6.5.1).

3.1.2.6.10.1.1 *Alert.* An alert condition shall be reported in the FS field if the Mode A identity code transmitted in Mode A replies and in downlink formats DF equals 5 and DF equals 21 are changed by the pilot.

3.1.2.6.10.1.1.1 *Permanent alert condition.* The alert condition shall be maintained if the Mode A identity code is changed to 7500, 7600 or 7700.

3.1.2.6.10.1.1.2 *Temporary alert condition.* The alert condition shall be temporary and shall cancel itself after  $T_C$  seconds if the Mode A identity code is changed to a value other than those listed in 3.1.2.6.10.1.1.1. The  $T_C$  shall be retrigged and continued for  $T_C$  seconds after any change has been accepted by the transponder function.

*Note 1.— This retrigging is performed to ensure that the ground interrogator obtains the desired Mode A identity code before the alert condition is cleared.*

*Note 2.— The value of  $T_C$  is given in 3.1.2.10.3.9.*

3.1.2.6.10.1.1.3 *Termination of the permanent alert condition.* The permanent alert condition shall be terminated and replaced by a temporary alert condition when the Mode A identity code is set to a value other than 7500, 7600 or 7700.

3.1.2.6.10.1.2 *Ground report.* The on-the-ground status of the aircraft shall be reported in the CA field (3.1.2.5.2.2.1), the FS field (3.1.2.6.5.1), and the VS field (3.1.2.8.2.1). If an automatic indication of the on-the-ground condition (e.g. from a weight on wheels or strut switch) is available at the transponder data interface, it shall be used as the basis for the reporting of on-the-ground status except as specified in 3.1.2.6.10.3.1 and 3.1.2.8.6.7. If such indication is not available at the transponder data interface (3.1.2.10.5.1.3), the FS and VS codes shall indicate that the aircraft is airborne and the CA field shall indicate that the aircraft is either airborne or on the ground (CA = 6) except as indicated in 3.1.2.8.6.7.

3.1.2.6.10.1.3 *Special position identification (SPI).* An equivalent of the SPI pulse shall be transmitted by Mode S transponders in the FS field and the surveillance status subfield (SSS) when manually activated. This pulse shall be transmitted for  $T_I$  seconds after initiation (3.1.1.6.3, 3.1.1.7.13 and 3.1.2.8.6.3.1.1).

*Note.— The value of  $T_I$  is given in 3.1.2.10.3.9.*

3.1.2.6.10.2 *Capability reporting protocol.* The data structure and content of the data link capability report registers shall be implemented in such a way that interoperability is ensured.

*Note 1.— Aircraft capability is reported in special fields as defined in the following paragraphs.*

*Note 2.— The data format of the registers for reporting capability is specified in the Technical Provisions for Mode S Services and Extended Squitter (Doc 9871).*

3.1.2.6.10.2.1 *Capability report.* The 3-bit CA field, contained in the all-call reply, DF equals 11, shall report the basic capability of the Mode S transponder as described in 3.1.2.5.2.2.1.

3.1.2.6.10.2.2 *Data link capability report.* The data link capability report shall provide the interrogator with a description of the data link capability of the Mode S installation.

*Note.— The data link capability report is contained in register 10<sub>16</sub> with a possible extension in registers 11<sub>16</sub> to 16<sub>16</sub> when any continuation will be required.*

### 3.1.2.6.10.2.2.1 Extraction and subfields in MB for data link capability report

3.1.2.6.10.2.2.1.1 *Extraction of the data link capability report contained in register 10<sub>16</sub>*. The report shall be obtained by a ground-initiated Comm-B reply in response to an interrogation containing RR equals 17 and DI is not equal to 7 or DI equals 7 and RRS equals 0 (3.1.2.6.11.2).

3.1.2.6.10.2.2.1.2 *Sources of data link capability*. Data link capability reports shall contain the capabilities provided by the transponder, the ADLP and the ACAS unit. If external inputs are lost, the transponder shall zero the corresponding bits in the data link report.

3.1.2.6.10.2.2.1.3 The data link capability report shall contain information on the following capabilities as specified in Table 3-6.

3.1.2.6.10.2.2.1.4 The Mode S subnetwork version number shall contain information to ensure interoperability with older airborne equipment.

3.1.2.6.10.2.2.1.4.1 The Mode S subnetwork version number shall indicate that all implemented subnetwork functions are in compliance with the requirements of the indicated version number. The Mode S subnetwork version number shall be set to a non-zero value if at least one DTE or Mode S specific service is installed.

*Note.— The version number does not indicate that all possible functions of that version are implemented.*

3.1.2.6.10.2.2.2 *Updating of the data link capability report*. The transponder shall, at intervals not exceeding four seconds, compare the current data link capability status (bits 41-88 in the data link capability report) with that last reported and shall, if a difference is noted, initiate a revised data link capability report by Comm-B broadcast (3.1.2.6.11.4) for BDS1 = 1 (33-36) and BDS 2 = 0 (37-40). The transponder shall initiate, generate and announce the revised capability report even if the aircraft data link capability is degraded or lost. The transponder shall ensure that the BDS code is set for the data link capability report in all cases, including a loss of the interface.

*Note.— The setting of the BDS code by the transponder ensures that a broadcast change of capability report will contain the BDS code for all cases of data link failure (e.g. the loss of the transponder data link interface).*

### 3.1.2.6.10.2.2.3 Zeroing of bits in the data link capability report

If capability information to the transponder fails to provide an update at a rate of at least once every 4 seconds, the transponder shall insert ZERO in bits 41 to 56 of the data link capability report (transponder register 10<sub>16</sub>).

*Note.— Bits 1 to 8 contain the BDS1 and BDS2 codes. Bits 16 and 37 to 40 contain ACAS capability information. Bit 33 indicates the availability of aircraft identification data and is set by the transponder when the data comes from a separate interface and not from the ADLP. Bit 35 is the SI code indication. All of these bits are inserted by the transponder.*

3.1.2.6.10.2.3 *Common usage GICB capability report*. Common usage GICB services which are being actively updated shall be indicated in transponder register 17<sub>16</sub>.

3.1.2.6.10.2.4 *Mode S specific services GICB capability reports*. GICB services that are installed shall be reported in registers 18<sub>16</sub> to 1C<sub>16</sub>.

3.1.2.6.10.2.5 *Mode S specific services MSP capability reports*. MSP services that are installed shall be reported in registers 1D<sub>16</sub> to 1F<sub>16</sub>.



## 3.1.2.6.10.3 Validation of on-the-ground status declared by an automatic means

*Note.*— For aircraft with an automatic means of determining vertical status, the CA field reports whether the aircraft is airborne or on the ground. ACAS II acquires aircraft using the short or extended squitter, both of which contain the CA field. If an aircraft reports on-the-ground status, that aircraft will not be interrogated by ACAS II in order to reduce unnecessary interrogation activity. If the aircraft is equipped to report extended squitter messages, the function that formats these messages may have information available to validate that an aircraft reporting “on-the-ground” is actually airborne.

3.1.2.6.10.3.1 Aircraft with an automatic means for determining the on-the-ground state on which transponders have access to at least one of the parameters, ground speed, radio altitude or airspeed, shall perform the following validation check:

If the automatically determined air/ground status is not available or is “airborne”, no validation shall be performed. If the automatically determined air/ground status is available and “on-the-ground” condition is being reported or if the on-the-ground status has been commanded via the TCS subfield (3.1.2.6.1.4.1 f)), the air/ground status shall be overridden and changed to “airborne” if:

Ground Speed > 100 knots OR Airspeed > 100 knots OR Radio Altitude > 50 feet

## 3.1.2.6.11 STANDARD LENGTH COMMUNICATIONS PROTOCOLS

*Note 1.*— The two types of standard length communications protocols are Comm-A and Comm-B; messages using these protocols are transferred under the control of the interrogator. Comm-A messages are sent directly to the transponder and are completed within one transaction. A Comm-B message is used to transfer information from air to ground and can be initiated either by the interrogator or the transponder. In the case of ground-initiated Comm-B transfers, the interrogator requests data to be read out from the transponder, which delivers the message in the same transaction. In the case of air-initiated Comm-B transfers, the transponder announces the intention to transmit a message; in a subsequent transaction an interrogator will extract the message.

*Note 2.*— In a non-selective air-initiated Comm-B protocol all transactions necessary can be controlled by any interrogator.

*Note 3.*— In some areas of overlapping interrogator coverage there may be no means for coordinating interrogator activities via ground communications. Air-initiated Comm-B communications protocols require more than one transaction for completion. Provision is made to ensure that a Comm-B message is closed out only by the interrogator that actually transferred the message. This can be accomplished through the use of the multisite Comm-B communications protocols or through the use of the enhanced Comm-B communications protocols.

*Note 4.*— The multisite and the non-selective communications protocols cannot be used simultaneously in a region of overlapping interrogator coverage unless the interrogators coordinate their communications activities via ground communications.

*Note 5.*— The multisite communications protocol is independent of the multisite lockout protocol. That is, the multisite communications protocol may be used with the non-selective lockout protocol and vice versa. The choice of lockout and communications protocols to be used depends upon the network management technique being used.

*Note 6.*— The broadcast Comm-B protocol can be used to make a message available to all active interrogators.

3.1.2.6.11.1 Comm-A. The interrogator shall deliver a Comm-A message in the MA field of an interrogation UF = 20 or 21.

3.1.2.6.11.1.1 Comm-A technical acknowledgement. Acceptance of a Comm-A interrogation shall be automatically technically acknowledged by the transponder, by the transmission of the requested reply (3.1.2.10.5.2.2.1).

*Note.*— The receipt of a reply from the transponder according to the rules of 3.1.2.4.1.2.3 d) and 3.1.2.4.1.3.2.2.2 is the acknowledgement to the interrogator that the interrogation has been accepted by the transponder. If either uplink or downlink fail, this reply will be missing and the interrogator will normally send the message again. In the case of downlink failure, the transponder may receive the message more than once.

3.1.2.6.11.1.2 *Comm-A broadcast.* If a Comm-A broadcast interrogation is accepted (3.1.2.4.1.2.3.1.3) information transfer shall be handled according to 3.1.2.10.5.2.1.1 but other transponder functions shall not be affected and a reply shall not be transmitted.

*Note 1.*— There is no technical acknowledgement to a Comm-A broadcast message.

*Note 2.*— Since the transponder does not process the control fields of a Comm-A broadcast interrogation, the 27 bits following the UF field are also available for user data.

### 3.1.2.6.11.2 *Ground-initiated Comm-B*

3.1.2.6.11.2.1 *Comm-B data selector, BDS.* The 8-bit BDS code shall determine the register whose contents shall be transferred in the MB field of the Comm-B reply. It shall be expressed in two groups of 4 bits each, BDS1 (most significant 4 bits) and BDS2 (least significant 4 bits).

*Note.*— The transponder register allocation is specified in Annex 10, Volume III, Part I, Chapter 5, Table 5-24.

3.1.2.6.11.2.2 *BDS1 code.* The BDS1 code shall be as defined in the RR field of a surveillance or Comm-A interrogation.

3.1.2.6.11.2.3 *BDS2 code.* The BDS2 code shall be as defined in the RRS subfield of the SD field (3.1.2.6.1.4.1) when DI = 7. If no BDS2 code is specified (i.e. DI is not equal to 7) it shall signify that BDS2 = 0.

3.1.2.6.11.2.4 *Protocol.* On receipt of such a request, the MB field of the reply shall contain the contents of the requested ground-initiated Comm-B register.

### 3.1.2.6.11.3 *Air-initiated Comm-B*

3.1.2.6.11.3.1 *General protocol.* The transponder shall announce the presence of an air-initiated Comm-B message with the insertion of code 1 in the DR field. To extract an air-initiated Comm-B message, the interrogator shall transmit a request for a Comm-B message reply in a subsequent interrogation with RR equal to 16 and, if DI equals 7, RRS must be equal to 0 (3.1.2.6.11.3.2.1 and 3.1.2.6.11.3.3.1). Receipt of this request code shall cause the transponder to transmit the air-initiated Comm-B message. If a command to transmit an air-initiated Comm-B message is received while no message is waiting to be transmitted, the reply shall contain all ZEROs in the MB field.

The reply that delivers the message shall continue to contain code 1 in the DR field. After a Comm-B closeout has been accomplished, the message shall be cancelled and the DR code belonging to this message immediately removed. If another air-initiated Comm-B message is waiting to be transmitted, the transponder shall set the DR code to 1, so that the reply contains the announcement of this next message.

*Note.*— The announcement and cancellation protocol ensures that an air-initiated message will not be lost due to uplink or downlink failures that occur during the delivery process.

3.1.2.6.11.3.2 *Additional protocol for multisite air-initiated Comm-B*

*Note.*— The announcement of an air-initiated Comm-B message waiting to be delivered may be accompanied by a multisite reservation status report in the UM field (3.1.2.6.5.3.2).

**Recommendation.**— *An interrogator should not attempt to extract a message if it has determined that it is not the reserved site.*

3.1.2.6.11.3.2.1 *Message transfer.* An interrogator shall request a Comm-B reservation and extract an air-initiated Comm-B message by transmitting a surveillance or Comm-A interrogation UF equals 4, 5, 20 or 21 containing:

RR = 16  
 DI = 1  
 IIS = assigned interrogator identifier  
 MBS = 1 (Comm-B reservation request)

*Note.*— *A Comm-B multisite reservation request is normally accompanied by a Comm-B reservation status request (RSS = 1). This causes the interrogator identifier of the reserved site to be inserted in the UM field of the reply.*

3.1.2.6.11.3.2.1.1 Protocol procedure in response to this interrogation shall depend upon the state of the B-timer which indicates if a Comm-B reservation is active. This timer shall run for  $T_R$  seconds.

*Note 1.*— *The value of  $T_R$  is given in 3.1.2.10.3.9.*

- a) If the B-timer is not running, the transponder shall grant a reservation to the requesting interrogator by:
  - 1) storing the IIS of the interrogation as the Comm-B II; and
  - 2) starting the B-timer.

A multisite Comm-B reservation shall not be granted by the transponder unless an air-initiated Comm-B message is waiting to be transmitted and the requesting interrogation contains RR equals 16, DI equals 1, MBS equals 1 and IIS is not 0.

- b) If the B-timer is running and the IIS of the interrogation equals the Comm-B II, the transponder shall restart the B-timer.
- c) If the B-timer is running and the IIS of the interrogation does not equal the Comm-B II, then there shall be no change to the Comm-B II or the B-timer.

*Note 2.*— *In case c) the reservation request has been denied.*

3.1.2.6.11.3.2.1.2 In each case the transponder shall reply with the Comm-B message in the MB field.

3.1.2.6.11.3.2.1.3 An interrogator shall determine if it is the reserved site for this message through coding in the UM field. If it is the reserved site it shall attempt to close out the message in a subsequent interrogation. If it is not the reserved site it shall not attempt to close out the message.

3.1.2.6.11.3.2.2 *Multisite-directed Comm-B transmissions.* To direct an air-initiated Comm-B message to a specific interrogator, the multisite Comm-B protocol shall be used. When the B-timer is not running, the interrogator identifier of the desired destination shall be stored as the Comm-B II. Simultaneously the B-timer shall be started and the DR code shall be set to 1. For a multisite-directed Comm-B message, the B-timer shall not automatically time out but shall continue to run until:

- a) the message is read and closed out by the reserved site; or
- b) the message is cancelled (3.1.2.10.5.4) by the data link avionics.

*Note.*— *The protocols of 3.1.2.6.5.3 and 3.1.2.6.11.3.2.1 will then result in delivery of the message to the reserved site. The data link avionics may cancel the message if delivery to the reserved site cannot be accomplished.*

3.1.2.6.11.3.2.3 *Multisite Comm-B closeout.* The interrogator shall close out a multisite air-initiated Comm-B by transmitting either a surveillance or a Comm-A interrogation containing:

- either* DI = 1  
 IIS = assigned interrogator identifier  
 MBS = 2 (Comm-B closeout)
- or* DI = 0, 1 or 7  
 IIS = assigned interrogator identifier  
 PC = 4 (Comm-B closeout)

The transponder shall compare the IIS of the interrogation to the Comm-B II and if the interrogator identifiers do not match, the message shall not be cleared and the status of the Comm-B II, B-timer, and DR code shall not be changed. If the interrogator identifiers match, the transponder shall set the Comm-B II to 0, reset the B-timer, clear the DR code for this message and clear the message itself. The transponder shall not close out a multisite air-initiated Comm-B message unless it has been read out at least once by the reserved site.

3.1.2.6.11.3.2.4 *Automatic expiration of Comm-B reservation.* If the B-timer period expires before a multisite closeout has been accomplished, the Comm-B II shall be set to 0 and the B-timer reset. The Comm-B message and the DR field shall not be cleared by the transponder.

*Note.— This makes it possible for another site to read and clear this message.*

#### 3.1.2.6.11.3.3 *Additional protocol for non-selective air-initiated Comm-B*

*Note.— In cases where the multisite protocols are not required (i.e. no overlapping coverage or sensor coordination via ground-to-ground communication), the non-selective air-initiated Comm-B protocol may be used.*

3.1.2.6.11.3.3.1 *Message transfer.* The interrogator shall extract the message by transmitting either RR equals 16 and DI is not equal to 7, or RR equals 16, DI equals 7 and RRS equals 0 in a surveillance or Comm-A interrogation.

3.1.2.6.11.3.3.2 *Comm-B closeout.* The interrogator shall close out a non-selective air-initiated Comm-B message by transmitting PC equals 4 (Comm-B closeout). On receipt of this command, the transponder shall perform closeout, unless the B-timer is running. If the B-timer is running, indicating that a multisite reservation is in effect, closeout shall be accomplished as per 3.1.2.6.11.3.2.3. The transponder shall not close out a non-selective air-initiated Comm-B message unless it has been read out at least once by an interrogation using non-selective protocols.

#### 3.1.2.6.11.3.4 *Enhanced air-initiated Comm-B protocol*

*Note.— The enhanced air-initiated Comm-B protocol provides a higher data link capacity by permitting parallel delivery of air-initiated Comm-B messages by up to sixteen interrogators, one for each II code. Operation without the need for multisite Comm-B reservations is possible in regions of overlapping coverage for interrogators equipped for the enhanced air-initiated Comm-B protocol. The protocol is fully conformant to the standard multisite protocol and thus is compatible with interrogators that are not equipped for the enhanced protocol.*

3.1.2.6.11.3.4.1 The transponder shall be capable of storing each of the sixteen II codes: (1) an air-initiated or multisite-directed Comm-B message and (2) the contents of GICB registers 2 through 4.

*Note.— GICB registers 2 through 4 are used for the Comm-B linking protocol defined in the Mode S subnetwork SARPs (Annex 10, Volume III, Part I, Chapter 5).*

#### 3.1.2.6.11.3.4.2 *Enhanced multisite air-initiated Comm-B protocol*

3.1.2.6.11.3.4.2.1 *Initiation.* An air-initiated Comm-B message input into the transponder shall be stored in the registers assigned to  $II = 0$ .

3.1.2.6.11.3.4.2.2 *Announcement and extraction.* A waiting air-initiated Comm-B message shall be announced in the DR field of the replies to all interrogators for which a multisite directed Comm-B message is not waiting. The UM field of the announcement reply shall indicate that the message is not reserved for any II code, i.e. the IIS subfield shall be set to 0. When a command to read this message is received from a given interrogator, the reply containing the message shall contain an IIS subfield content indicating that the message is reserved for the II code contained in the interrogation from that interrogator. After readout and until closeout, the message shall continue to be assigned to that II code. Once a message is assigned to a specific II code, announcement of this message shall be no longer made in the replies to interrogators with other II codes. If the message is not closed out by the assigned interrogator for the period of the B-timer, the message shall revert back to multisite air-initiated status and the process shall repeat. Only one multisite air-initiated Comm-B message shall be in process at a time.

3.1.2.6.11.3.4.2.3 *Closeout.* A closeout for a multisite air-initiated message shall only be accepted from the interrogator that is currently assigned to transfer the message.

3.1.2.6.11.3.4.2.4 *Announcement of the next message waiting.* The DR field shall indicate a message waiting in the reply to an interrogation containing a Comm-B closeout if an unassigned air-initiated message is waiting and has not been assigned to a II code, or if a multisite-directed message is waiting for that II code (3.1.2.6.11.3.4.3).

#### 3.1.2.6.11.3.4.3 *Enhanced multisite directed Comm-B protocol*

3.1.2.6.11.3.4.3.1 *Initiation.* When a multisite directed message is input into the transponder, it shall be placed in the Comm-B registers assigned to the II code specified for the message. If the registers for this II code are already occupied, (i.e. a multisite directed message is already in process to this II code) the new message shall be queued until the current transaction with that II code is closed out.

3.1.2.6.11.3.4.3.2 *Announcement.* Announcement of a Comm-B message waiting transfer shall be made using the DR field as specified in 3.1.2.6.5.2 with the destination interrogator II code contained in the IIS subfield as specified in 3.1.2.6.5.3.2. The DR field and IIS subfield contents shall be set specifically for the interrogator that is to receive the reply. A waiting multisite directed message shall only be announced in the replies to the intended interrogator. It shall not be announced in the replies to other interrogators.

*Note 1.— If a multisite-directed message is waiting for  $II = 2$ , the surveillance replies to that interrogator will contain  $DR = 1$  and  $IIS = 2$ . If this is the only message in process, replies to all other interrogators will indicate that no message is waiting.*

*Note 2.— In addition to permitting parallel operation, this form of announcement enables a greater degree of announcement of downlink ELMs. The announcements for the downlink ELM and the Comm-B share the DR field. Only one announcement can take place at a time due to coding limitations. In case both a Comm-B and a downlink ELM are waiting, announcement preference is given to the Comm-B. In the example above, if an air-directed Comm-B was waiting for  $II = 2$  and a multisite-directed downlink ELM was waiting for  $II = 6$ , both interrogators would see their respective announcements on the first scan since there would be no Comm-B announcement to  $II = 6$  to block the announcement of the waiting downlink ELM.*

3.1.2.6.11.3.4.3.3 *Closeout.* Closeout shall be accomplished as specified in 3.1.2.6.11.3.2.3.

3.1.2.6.11.3.4.3.4 *Announcement of the next message waiting.* The DR field shall indicate a message waiting in the reply to an interrogation containing a Comm-B closeout if another multisite directed message is waiting for that II code, or if an air-initiated message is waiting and has not been assigned to a II code. (See 3.1.2.6.11.3.4.2.4.)

3.1.2.6.11.3.4.4 *Enhanced non-selective Comm-B protocol.* The availability of a non-selective Comm-B message shall be announced to all interrogators. Otherwise, the protocol shall be as specified in 3.1.2.6.11.3.3.

3.1.2.6.11.4 *Comm-B broadcast*

*Note 1.*— A *Comm-B* message may be broadcast to all active interrogators within range. Messages are alternately numbered 1 and 2 and are self-cancelling after 18 seconds. Interrogators have no means to cancel *Comm-B* broadcast messages.

*Note 2.*— Use of the *Comm-B* broadcast is restricted to transmission of information which does not require a subsequent ground-initiated uplink response.

*Note 3.*— The timer used for the *Comm-B* broadcast cycle is the same as that used for the *Comm-B* multisite protocol.

*Note 4.*— Data formats for *Comm-B* broadcast are specified in the Technical Provisions for Mode S Services and Extended Squitter (*Doc 9871*).

3.1.2.6.11.4.1 *Initiation.* A *Comm-B* broadcast cycle shall not be initiated when an air-initiated *Comm-B* is waiting to be transmitted. A *Comm-B* broadcast cycle shall begin with:

- a) the insertion of DR code 4 or 5, (3.1.2.6.5.2) into replies with DF 4, 5, 20 or 21; and
- b) the starting of the B-timer.

3.1.2.6.11.4.2 *Extraction.* To extract the broadcast message, an interrogator shall transmit RR equals 16 and DI not equal to 7 or RR equals 16 and DI equals 7 with RRS equals 0 in a subsequent interrogation.

3.1.2.6.11.4.3 *Expiration.* When the B-timer period expires, the transponder shall clear the DR code for this message, discard the present broadcast message and change the broadcast message number (from 1 to 2 or 2 to 1) in preparation for a subsequent *Comm-B* broadcast.

3.1.2.6.11.4.4 *Interruption.* In order to prevent a *Comm-B* broadcast cycle from delaying the delivery of an air-initiated *Comm-B* message, provision shall be made for an air-initiated *Comm-B* to interrupt a *Comm-B* broadcast cycle. If a broadcast cycle is interrupted, the B-timer shall be reset, the interrupted broadcast message shall be retained and the message number shall not be changed. Delivery of the interrupted broadcast message shall recommence when no air-initiated *Comm-B* transaction is in effect. The message shall then be broadcast for the full duration of the B-timer.

3.1.2.6.11.4.5 *Enhanced broadcast Comm-B protocol.* A broadcast *Comm-B* message shall be announced to all interrogators using II codes. The message shall remain active for the period of the B-timer for each II code. The provision for interruption of a broadcast by non-broadcast *Comm-B* as specified in 3.1.2.6.11.4.4 shall apply separately to each II code. When the B-timer period has been achieved for all II codes, the broadcast message shall be automatically cleared as specified in 3.1.2.6.11.4.3. A new broadcast message shall not be initiated until the current broadcast has been cleared.

*Note.*— Due to the fact that broadcast message interruption occurs independently for each II code, it is possible that the broadcast message timeout will occur at different times for different II codes.

## 3.1.2.7 EXTENDED LENGTH COMMUNICATION TRANSACTIONS

*Note 1.*— Long messages, either on the uplink or the downlink, can be transferred by the extended length message (ELM) protocols through the use of *Comm-C* ( $UF = 24$ ) and *Comm-D* ( $DF = 24$ ) formats respectively. The ELM uplink protocol provides for the transmission on the uplink of up to sixteen 80-bit message segments before requiring a reply from the transponder. They also allow a corresponding procedure on the downlink.

*Note 2.— In some areas of overlapping interrogator coverage there may be no means for coordinating interrogator activities via ground communications. However, the ELM communication protocols require more than one transaction for completion; coordination is thus necessary to ensure that segments from different messages are not interleaved and that transactions are not inadvertently closed out by the wrong interrogator. This can be accomplished through the use of the multisite communications protocols or through the use of the enhanced ELM protocols.*

*Note 3.— Downlink extended length messages are transmitted only after authorization by the interrogator. The segments to be transmitted are contained in Comm-D replies. As with air-initiated Comm-B messages, downlink ELMs are either announced to all interrogators or directed to a specific interrogator. In the former case an individual interrogator can use the multisite protocol to reserve for itself the ability to close out the downlink ELM transaction. A transponder can be instructed to identify the interrogator that has reserved the transponder for an ELM transaction. Only that interrogator can close out the ELM transaction and reservation.*

*Note 4.— The multisite protocol and the non-selective protocol cannot be used simultaneously in a region of overlapping interrogator coverage unless the interrogators coordinate their communications activities via ground communications.*

#### 3.1.2.7.1 COMM-C, UPLINK FORMAT 24

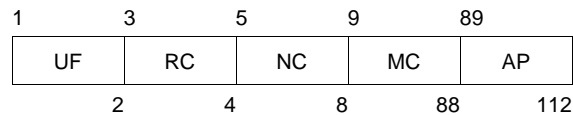

The format of this interrogation shall consist of these fields:

<i>Field</i>	<i>Reference</i>
UF uplink format	3.1.2.3.2.1.1
RC reply control	3.1.2.7.1.1
NC number of C-segment	3.1.2.7.1.2
MC message, Comm-C	3.1.2.7.1.3
AP address/parity	3.1.2.3.2.1.3

3.1.2.7.1.1 *RC: Reply control.* This 2-bit (3-4) uplink field shall designate segment significance and reply decision.

##### *Coding*

- RC = 0 signifies uplink ELM initial segment in MC
- = 1 signifies uplink ELM intermediate segment in MC
- = 2 signifies uplink ELM final segment in MC
- = 3 signifies a request for downlink ELM delivery (3.1.2.7.7.2)

3.1.2.7.1.2 *NC: Number of C-segment.* This 4-bit (5-8) uplink field shall designate the number of the message segment contained in MC (3.1.2.7.4.2.1). NC shall be coded as a binary number.

3.1.2.7.1.3 *MC: Message, Comm-C.* This 80-bit (9-88) uplink field shall contain:

- a) one of the segments of a sequence used to transmit an uplink ELM to the transponder containing the 4-bit (9-12) IIS subfield; or
- b) control codes for a downlink ELM, the 16-bit (9-24) SRS subfield (3.1.2.7.7.2.1) and the 4-bit (25-28) IIS subfield.

*Note.— Message content and codes are not included in this chapter except for 3.1.2.7.7.2.1.*

## 3.1.2.7.2 INTERROGATION-REPLY PROTOCOL FOR UF24

Note.— Interrogation-reply coordination for the above format follows the protocol outlined in Table 3-5 (3.1.2.4.1.3.2.2).

## 3.1.2.7.3 COMM-D, DOWNLINK FORMAT 24

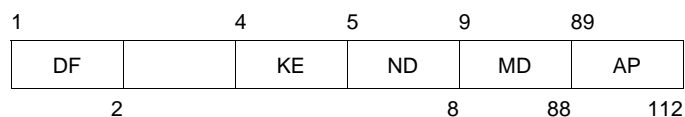

The format of this reply shall consist of these fields:

<i>Field</i>	<i>Reference</i>
DF downlink format spare — 1 bit	3.1.2.3.2.1.2
KE control, ELM	3.1.2.7.3.1
ND number of D-segment	3.1.2.7.3.2
MD message, Comm-D	3.1.2.7.3.3
AP address/parity	3.1.2.3.2.1.3

3.1.2.7.3.1 *KE: Control, ELM.* This 1-bit (4) downlink field shall define the content of the ND and MD fields.

*Coding*

KE = 0 signifies downlink ELM transmission  
1 signifies uplink ELM acknowledgement

3.1.2.7.3.2 *ND: Number of D-segment.* This 4-bit (5-8) downlink field shall designate the number of the message segment contained in MD (3.1.2.7.7.2). ND shall be coded as a binary number.

3.1.2.7.3.3 *MD: Message, Comm-D.* This 80-bit (9-88) downlink field shall contain:

- a) one of the segments of a sequence used to transmit a downlink ELM to the interrogator; or
- b) control codes for an uplink ELM.

## 3.1.2.7.4 MULTISITE UPLINK ELM PROTOCOL

3.1.2.7.4.1 *Multisite uplink ELM reservation.* An interrogator shall request a reservation for an uplink ELM by transmitting a surveillance or Comm-A interrogation containing:

DI = 1  
IIS = assigned interrogator identifier  
MES = 1 or 5 (uplink ELM reservation request)

Note.— A multisite uplink ELM reservation request is normally accompanied by an uplink ELM reservation status request (RSS = 2). This causes the interrogator identifier of the reserved site to be inserted in the UM field of the reply.

3.1.2.7.4.1.1 Protocol procedure in response to this interrogation shall depend upon the state of the C-timer which indicates if an uplink ELM reservation is active. This timer shall run for  $T_R$  seconds.



*Note 1.— The value of  $T_R$  is given in 3.1.2.10.3.9.*

- a) If the C-timer is not running, the transponder shall grant a reservation to the requesting interrogator by:
  - 1) storing the IIS of the interrogation as the Comm-C II and,
  - 2) starting the C-timer.
- b) If the C-timer is running and the IIS of the interrogation equals the Comm-C II, the transponder shall restart the C-timer.
- c) If the C-timer is running and the IIS of the interrogation does not equal the Comm-C II, there shall be no change to the Comm-C II or the C-timer.

*Note 2.— In case c) the reservation request has been denied.*

3.1.2.7.4.1.2 An interrogator shall not start ELM activity unless, during the same scan, having requested an uplink ELM status report, it has received its own interrogator identifier as the reserved interrogator for uplink ELM in the UM field.

*Note.— If ELM activity is not started during the same scan as the reservation, a new reservation request may be made during the next scan.*

3.1.2.7.4.1.3 If uplink ELM delivery is not completed on the current scan, the interrogator shall ensure that it still has a reservation before delivering additional segments on a subsequent scan.

3.1.2.7.4.2 *Multisite uplink ELM delivery.* The minimum length of an uplink ELM shall be 2 segments, the maximum length shall be 16 segments.

3.1.2.7.4.2.1 *Initial segment transfer.* The interrogator shall begin the ELM uplink delivery for an n-segment message (NC values from 0 to n-1) by a Comm-C transmission containing RC equals 0. The message segment transmitted in the MC field shall be the last segment of the message and shall carry NC equals n-1.

On receipt of an initializing segment (RC = 0) the transponder shall establish a “setup” defined as:

- a) clearing the number and content of previous segment storage registers and the associated TAS field;
- b) assigning storage space for the number of segments announced in NC of this interrogation; and
- c) storing the MC field of the segment received.

The transponder shall not reply to this interrogation.

Receipt of another initializing segment shall result in a new setup within the transponder.

3.1.2.7.4.2.2 *Transmission acknowledgement.* The transponder shall use the TAS subfield to report the segments received so far in an uplink ELM sequence. The information contained in the TAS subfield shall be continually updated by the transponder as segments are received.

*Note.— Segments lost in uplink transmission are noted by their absence in the TAS report and are retransmitted by the interrogator which will then send further final segments to assess the extent of message completion.*

3.1.2.7.4.2.2.1 *TAS, transmission acknowledgement subfield in MD.* This 16-bit (17-32) downlink subfield in MD reports the segment numbers received so far in an uplink ELM sequence. Starting with bit 17, which denotes segment number 0,

each of the following bits shall be set to ONE if the corresponding segment of the sequence has been received. TAS shall appear in MD if KE equals 1 in the same reply.

3.1.2.7.4.2.3 *Intermediate segment transfer.* The interrogator shall transfer intermediate segments by transmitting Comm-C interrogations with RC equals 1. The transponder shall store the segments and update TAS only if the setup of 3.1.2.7.4.2.1 is in effect and if the received NC is smaller than the value stored at receipt of the initial segment. No reply shall be generated on receipt of an intermediate segment.

*Note.*— *Intermediate segments may be transmitted in any order.*

3.1.2.7.4.2.4 *Final segment transfer.* The interrogator shall transfer a final segment by transmitting a Comm-C interrogation with RC equals 2. The transponder shall store the content of the MC field and update TAS if the setup of 3.1.2.7.4.2.1 is in effect and if the received NC is smaller than the value of the initial segment NC. The transponder shall reply under all circumstances as per 3.1.2.7.4.2.5.

*Note 1.*— *This final segment transfer interrogation can contain any message segment.*

*Note 2.*— *RC equals 2 is transmitted any time that the interrogator wants to receive the TAS subfield in the reply. Therefore, more than one “final” segment may be transferred during the delivery of an uplink ELM.*

3.1.2.7.4.2.5 *Acknowledgement reply.* On receipt of a final segment, the transponder shall transmit a Comm-D reply (DF = 24), with KE equals 1 and with the TAS subfield in the MD field. This reply shall be transmitted at 128 microseconds plus or minus 0.25 microsecond following the sync phase reversal of the interrogation delivering the final segment.

3.1.2.7.4.2.6 *Completed message.* The transponder shall deem the message complete if all segments announced by NC in the initializing segment have been received. If the message is complete, the message content shall be delivered to the outside via the ELM interface of 3.1.2.10.5.2.1.3 and cleared. No later-arriving segments shall be stored. The TAS content shall remain unchanged until either a new setup is called for (3.1.2.7.4.2.1) or until closeout (3.1.2.7.4.2.8).

3.1.2.7.4.2.7 *C-timer restart.* The C-timer shall be restarted each time that a received segment is stored and the Comm-C II is not 0.

*Note.*— *The requirement for the Comm-C II to be non-zero prevents the C-timer from being restarted during a non-selective uplink ELM transaction.*

3.1.2.7.4.2.8 *Multisite uplink ELM closeout.* The interrogator shall close out a multisite uplink ELM by transmitting either a surveillance or a Comm-A interrogation containing:

*either* DI = 1  
 IIS = assigned interrogator identifier  
 MES = 2, 6 or 7 (uplink ELM closeout)

*or* DI = 0, 1 or 7  
 IIS = assigned interrogator identifier  
 PC = 5 (uplink ELM closeout)

The transponder shall compare the IIS of the interrogation to the Comm-C II and if the interrogator identifiers do not match, the state of the ELM uplink process shall not be changed.

If the interrogator identifiers match, the transponder shall set the Comm-C II to 0, reset the C-timer, clear the stored TAS and discard any stored segments of an incomplete message.

3.1.2.7.4.2.9 *Automatic multisite uplink ELM closeout.* If the C-timer period expires before a multisite closeout has been accomplished the closeout actions described in 3.1.2.7.4.2.8 shall be initiated automatically by the transponder.

#### 3.1.2.7.5 *NON-SELECTIVE UPLINK ELM*

*Note.— In cases where the multisite protocols are not required (for example, no overlapping coverage or sensor coordination via ground-to-ground communication), the non-selective uplink ELM protocol may be used.*

Non-selective uplink ELM delivery shall take place as for multisite uplink ELMs described in 3.1.2.7.4.2. The interrogator shall close out an uplink ELM by transmitting PC equals 5 (uplink ELM closeout) in a surveillance or Comm-A interrogation. On receipt of this command, the transponder shall perform closeout, unless the C-timer is running. If the C-timer is running, indicating that a multisite reservation is in effect, the closeout shall be accomplished as per 3.1.2.7.4.2.8. An uncompleted message, present when the closeout is accepted, shall be cancelled.

#### 3.1.2.7.6 *ENHANCED UPLINK ELM PROTOCOL*

*Note.— The enhanced uplink ELM protocol provides a higher data link capacity by permitting parallel delivery of uplink ELM messages by up to sixteen interrogators, one for each II code. Operation without the need for multisite uplink ELM reservations is possible in regions of overlapping coverage for interrogators equipped for the enhanced uplink ELM protocol. The protocol is fully conformant to the standard multisite protocol and thus is compatible with interrogators that are not equipped for the enhanced protocol.*

##### 3.1.2.7.6.1 *General*

3.1.2.7.6.1.1 The interrogator shall determine from the data link capability report whether the transponder supports the enhanced protocols. If the enhanced protocols are not supported by both the interrogator and the transponder, the multisite reservation protocols specified in 3.1.2.7.4.1 shall be used.

*Note.— If the enhanced protocols are supported, uplink ELMs delivered using the multisite protocol may be delivered without a prior reservation.*

3.1.2.7.6.1.2 **Recommendation.**— *If the transponder and the interrogator are equipped for the enhanced protocol, the interrogator should use the enhanced uplink protocol.*

3.1.2.7.6.1.3 The transponder shall be capable of storing a sixteen segment message for each of the sixteen II codes.

3.1.2.7.6.2 *Reservation processing.* The transponder shall support reservation processing for each II code as specified in 3.1.2.7.4.1

*Note 1.— Reservation processing is required for interrogators that do not support the enhanced protocol.*

*Note 2.— Since the transponder can process simultaneous uplink ELMs for all sixteen II codes, a reservation will always be granted.*

3.1.2.7.6.3 *Enhanced uplink ELM delivery and closeout.* The transponder shall process received segments separately by II code. For each value of II code, uplink ELM delivery and closeout shall be performed as specified in 3.1.2.7.4.2 except that the MD field used to transmit the technical acknowledgment shall also contain the 4-bit (33-36) IIS subfield.

*Note.— The interrogator may use the II code contained in the technical acknowledgement in order to verify that it has received the correct technical acknowledgement.*

## 3.1.2.7.7 MULTISITE DOWNLINK ELM PROTOCOL

3.1.2.7.7.1 *Initialization.* The transponder shall announce the presence of a downlink ELM of  $n$  segments by making the binary code corresponding to the decimal value  $15 + n$  available for insertion in the DR field of a surveillance or Comm-B reply, DF equals 4, 5, 20, 21. This announcement shall remain active until the ELM is closed out (3.1.2.7.7.3, 3.1.2.7.8.1).

3.1.2.7.7.1.1 *Multisite downlink ELM reservation.* An interrogator shall request a reservation for extraction of a downlink ELM by transmitting a surveillance or Comm-A interrogation containing:

DI = 1  
 IIS = assigned interrogator identifier  
 MES = 3 or 6 (downlink ELM reservation request)

*Note.*— A multisite downlink ELM reservation request is normally accompanied by a downlink ELM reservation status request (RSS = 3). This causes the interrogator identifier of the reserved interrogator to be inserted in the UM field of the reply.

3.1.2.7.7.1.1.1 Protocol procedure in response to this interrogation shall depend upon the state of the D-timer which indicates if a downlink ELM reservation is active. This timer shall run for  $T_R$  seconds.

*Note 1.*— The value of  $T_R$  is given in 3.1.2.10.3.9.

- a) if the D-timer is not running, the transponder shall grant a reservation to the requesting interrogator by:
  - 1) storing the IIS of the interrogation as the Comm-D II; and
  - 2) starting the D-timer.

A multisite downlink ELM reservation shall not be granted by the transponder unless a downlink ELM is waiting to be transmitted.

- b) if the D-timer is running and the IIS of the interrogation equals the Comm-D II, the transponder shall restart the D-timer; and
- c) if the D-timer is running and the IIS of the interrogation does not equal the Comm-D II, there shall be no change to the Comm-D II or D-timer.

*Note 2.*— In case c) the reservation request has been denied.

3.1.2.7.7.1.1.2 An interrogator shall determine if it is the reserved site through coding in the UM field and, if so, it is authorized to request delivery of the downlink ELM. Otherwise, ELM activity shall not be started during this scan.

*Note.*— If the interrogator is not the reserved site, a new reservation request may be made during the next scan.

3.1.2.7.7.1.1.3 If downlink ELM activity is not completed on the current scan, the interrogator shall ensure that it still has a reservation before requesting additional segments on a subsequent scan.

3.1.2.7.7.1.2 *Multisite-directed downlink ELM transmissions.* To direct a downlink ELM message to a specific interrogator, the multisite downlink ELM protocol shall be used. When the D-timer is not running, the interrogator identifier of the desired destination shall be stored as the Comm-D II. Simultaneously, the D-timer shall be started and the DR code (3.1.2.7.7.1) shall be set. For a multisite-directed downlink ELM, the D-timer shall not automatically time out but shall continue to run until:

- a) the message is read and closed out by the reserved site; or

b) the message is cancelled (3.1.2.10.5.4) by the data link avionics.

*Note.— The protocols of 3.1.2.7.7.1 will then result in the delivery of the message to the reserved site. The data link avionics may cancel the message if delivery to the reserved site cannot be accomplished.*

3.1.2.7.7.2 *Delivery of downlink ELMs.* The interrogator shall extract a downlink ELM by transmitting a Comm-C interrogation with RC equals 3. This interrogation shall carry the SRS subfield which specifies the segments to be transmitted. On receipt of this request, the transponder shall transfer the requested segments by means of Comm-D replies with KE equals 0 and ND corresponding to the number of the segment in MD. The first segment shall be transmitted 128 microseconds plus or minus 0.25 microsecond following the sync phase reversal of the interrogation requesting delivery and subsequent segments shall be transmitted at a rate of one every 136 microseconds plus or minus 1 microsecond. If a request is received to transmit downlink ELM segments and no message is waiting, each reply segment shall contain all ZEROs in the MD field.

*Note 1.— The requested segments may be transmitted in any order.*

*Note 2.— Segments lost in downlink transmissions will be requested again by the interrogator on a subsequent interrogation carrying the SRS subfield. This process is repeated until all segments have been transferred.*

3.1.2.7.7.2.1 *SRS, segment request subfield in MC.* This 16-bit (9-24) uplink subfield in MC shall request the transponder to transfer downlink ELM segments. Starting with bit 9, which denotes segment number 0, each of the following bits shall be set to ONE if the transmission of the corresponding segment is requested. SRS shall appear in MC if RC equals 3 in the same interrogation.

3.1.2.7.7.2.2 *D-timer restart.* The D-timer shall be restarted each time that a request for Comm-D segments is received if the Comm-D II is non-zero.

*Note.— The requirement for the Comm-D II to be non-zero prevents the D-timer from being restarted during a non-selective downlink ELM transaction.*

3.1.2.7.7.3 *Multisite downlink ELM closeout.* The interrogator shall close out a multisite downlink ELM by transmitting either a surveillance or a Comm-A interrogation containing:

*either* DI = 1  
 IIS = assigned interrogator identifier  
 MES = 4, 5 or 7 (downlink ELM closeout)

*or* DI = 0, 1 or 7  
 IIS = assigned interrogator identifier  
 PC = 6 (downlink ELM closeout).

The transponder shall compare the IIS of the interrogation to the Comm-D II and if the interrogator identifiers do not match, the state of the downlink process shall not be changed.

If the interrogator identifiers match, and if a request for transmission has been complied with at least once, the transponder shall set the Comm-D II to 0, reset the D-timer, clear the DR code for this message and clear the message itself.

If another downlink ELM is waiting to be transmitted, the transponder shall set the DR code (if no Comm-B message is waiting to be delivered) so that the reply contains the announcement of the next message.

3.1.2.7.7.4 *Automatic expiration of downlink ELM reservation.* If the D-timer period expires before a multisite closeout has been accomplished, the Comm-D II shall be set to 0, and the D-timer reset. The message and DR code shall not be cleared.

*Note.— This makes it possible for another site to read and clear this message.*

### 3.1.2.7.8 NON-SELECTIVE DOWNLINK ELM

*Note.*— In cases where the multisite protocols are not required (i.e. no overlapping coverage or sensor coordination via ground-to-ground communication), the non-selective downlink ELM protocol may be used.

Non-selective downlink ELM delivery shall take place as described in 3.1.2.7.7.2.

3.1.2.7.8.1 *Non-selective downlink ELM closeout.* The interrogator shall close out a non-selective downlink ELM by transmitting PC equals 6 (downlink ELM closeout) in a surveillance or Comm-A interrogation. On receipt of this command, and if a request for transmission has been complied with at least once, the transponder shall perform closeout unless the D-timer is running. If the D-timer is running, indicating that a multisite reservation is in effect, the closeout shall be accomplished as per 3.1.2.7.7.3.

### 3.1.2.7.9 ENHANCED DOWNLINK ELM PROTOCOL

*Note.*— The enhanced downlink ELM protocol provides a higher data link capacity by permitting parallel delivery of downlink ELM messages by up to sixteen interrogators, one for each II code. Operation without the need for multisite downlink ELM reservations is possible in regions of overlapping coverage for interrogators equipped for the enhanced downlink ELM protocol. The protocol is fully conformant to the standard multisite protocol and thus is compatible with interrogators that are not equipped for the enhanced protocol.

#### 3.1.2.7.9.1 General

3.1.2.7.9.1.1 The interrogator shall determine from the data link capability report whether the transponder supports the enhanced protocols. If the enhanced protocols are not supported by both the interrogator and the transponder, the multisite reservation protocols specified in 3.1.2.6.11 shall be used for multisite and multisite-directed downlink ELMs.

*Note.*— If the enhanced protocols are supported, downlink ELMs delivered using the multisite-directed protocol can be delivered without a prior reservation.

3.1.2.7.9.1.2 **Recommendation.**— If the transponder and the interrogator are equipped for the enhanced protocol, the interrogator should use the enhanced downlink protocol.

#### 3.1.2.7.9.2 Enhanced multisite downlink ELM protocol

3.1.2.7.9.2.1 The transponder shall be capable of storing a sixteen segment message for each of the sixteen II codes.

3.1.2.7.9.2.2 *Initialization.* A multisite message input into the transponder shall be stored in the registers assigned to II = 0.

3.1.2.7.9.2.3 *Announcement and extraction.* A waiting multisite downlink ELM message shall be announced in the DR field of the replies to all interrogators for which a multisite directed downlink ELM message is not waiting. The UM field of the announcement reply shall indicate that the message is not reserved for any II code, i.e. the IIS subfield shall be set to 0. When a command to reserve this message is received from a given interrogator, the message shall be reserved for the II code contained in the interrogation from that interrogator. After readout and until closeout, the message shall continue to be assigned to that II code. Once a message is assigned to a specific II code, announcement of this message shall no longer be made in the replies to interrogators with other II codes. If the message is not closed out by the associated interrogator for the period of the D-timer, the message shall revert back to multisite status and the process shall repeat. Only one multisite downlink ELM message shall be in process at a time.

3.1.2.7.9.2.4 *Closeout.* A closeout for a multisite message shall only be accepted from the interrogator that was assigned most recently to transfer the message.

3.1.2.7.9.2.5 *Announcement of the next message waiting.* The DR field shall indicate a message waiting in the reply to an interrogation containing a downlink ELM closeout if an unassigned multisite downlink ELM is waiting, or if a multisite directed message is waiting for that II code (3.1.2.7.9.2).

### 3.1.2.7.9.3 *Enhanced multisite directed downlink ELM protocol*

3.1.2.7.9.3.1 *Initialization.* When a multisite directed message is input into the transponder, it shall be placed in the downlink ELM registers assigned to the II code specified for the message. If the registers for this II code are already in use (i.e. a multisite directed downlink ELM message is already in process for this II code), the new message shall be queued until the current transaction with that II code is closed out.

3.1.2.7.9.3.2 *Announcement.* Announcement of a downlink ELM message waiting transfer shall be made using the DR field as specified in 3.1.2.7.7.1 with the destination interrogator II code contained in the IIS subfield as specified in 3.1.2.6.5.3.2. The DR field and IIS subfield contents shall be set specifically for the interrogator that is to receive the reply. A waiting multisite directed message shall only be announced in the replies to the intended interrogator. It shall not be announced in replies to other interrogators.

3.1.2.7.9.3.3 *Delivery.* An interrogator shall determine if it is the reserved site through coding in the UM field. The delivery shall only be requested if it is the reserved site and shall be as specified in 3.1.2.7.7.2. The transponder shall transmit the message contained in the buffer associated with the II code specified in the IIS subfield of the segment request interrogation.

3.1.2.7.9.3.4 *Closeout.* Closeout shall be accomplished as specified in 3.1.2.7.7.3 except that a message closeout shall only be accepted from the interrogator with a II code equal to the one that transferred the message.

3.1.2.7.9.3.5 *Announcement of the next message waiting.* The DR field shall indicate a message waiting in the reply to an interrogation containing a downlink ELM closeout if another multisite directed message is waiting for that II code, or if a downlink message is waiting that has not been assigned a II code (3.1.2.7.9.2).

3.1.2.7.9.4 *Enhanced non-selective downlink ELM protocol.* The availability of a non-selective downlink ELM message shall be announced to all interrogators. Otherwise, the protocol shall be as specified in 3.1.2.7.7.

## 3.1.2.8 AIR-AIR SERVICE AND SQUITTER TRANSACTIONS

*Note.*— Airborne collision avoidance system (ACAS) equipment uses the formats UF or DF equals 0 or 16 for air-air surveillance.

### 3.1.2.8.1 SHORT AIR-AIR SURVEILLANCE, UPLINK FORMAT 0

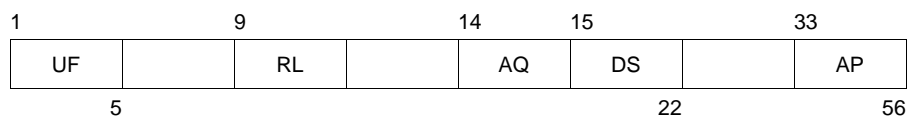

The format of this interrogation shall consist of these fields:

<i>Field</i>	<i>Reference</i>
UF uplink format	3.1.2.3.2.1.1
spare — 3 bits	
RL reply length	3.1.2.8.1.2

spare — 4 bits	
AQ acquisition	3.1.2.8.1.1
DS data selector	3.1.2.8.1.3
spare — 10 bits	
AP address/parity	3.1.2.3.2.1.3

3.1.2.8.1.1 *AQ: Acquisition.* This 1-bit (14) uplink field shall contain a code which controls the content of the RI field.

3.1.2.8.1.2 *RL: Reply length.* This 1-bit (9) uplink field shall command the format to be used for the reply.

#### Coding

0	signifies a reply with DF = 0
1	signifies a reply with DF = 16

*Note.*— A transponder that does not support DF = 16 (i.e. transponder which does not support the ACAS cross-link capability and is not associated with airborne collision avoidance equipment) would not reply to a UF=0 interrogation with RL=1.

3.1.2.8.1.3 *DS: Data selector.* This 8-bit (15-22) uplink field shall contain the BDS code (3.1.2.6.11.2.1) of the GICB register whose contents shall be returned to the corresponding reply with DF = 16.

#### 3.1.2.8.2 SHORT AIR-AIR SURVEILLANCE, DOWNLINK FORMAT 0

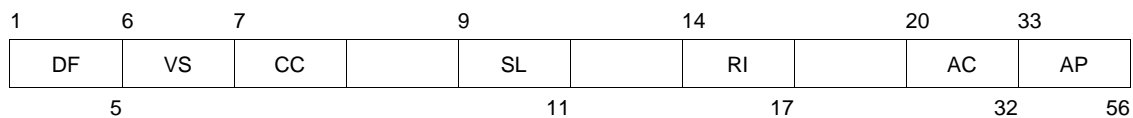

This reply shall be sent in response to an interrogation with UF equals 0 and RL equals 0. The format of this reply shall consist of these fields:

<i>Field</i>	<i>Reference</i>
DF downlink format	3.1.2.3.2.1.2
VS vertical status	3.1.2.8.2.1
CC cross-link capability	3.1.2.8.2.3
spare — 1 bit	
SL sensitivity level, ACAS	4.3.8.4.2.5
spare — 2 bits	
RI reply information	3.1.2.8.2.2
spare — 2 bits	
AC altitude code	3.1.2.6.5.4
AP address/parity	3.1.2.3.2.1.3

3.1.2.8.2.1 *VS: Vertical status:* This 1-bit (6) downlink field shall indicate the status of the aircraft (3.1.2.6.10.1.2).

#### Coding

0	signifies that the aircraft is airborne
1	signifies that the aircraft is on the ground

3.1.2.8.2.2 *RI: Reply information, air-air.* This 4-bit (14-17) downlink field shall report the aircraft's maximum cruising true airspeed capability and type of reply to interrogating aircraft. The coding shall be as follows:



- 0 signifies a reply to an air-air interrogation UF = 0 with AQ = 0, no operating ACAS
- 1-7 reserved for ACAS
- 8-15 signifies a reply to an air-air interrogation UF = 0 with AQ = 1 and that the maximum airspeed is as follows:
  - 8 no maximum airspeed data available
  - 9 maximum airspeed is .LE. 140 km/h (75 kt)
  - 10 maximum airspeed is .GT. 140 and .LE. 280 km/h (75 and 150 kt)
  - 11 maximum airspeed is .GT. 280 and .LE. 560 km/h (150 and 300 kt)
  - 12 maximum airspeed is .GT. 560 and .LE. 1 110 km/h (300 and 600 kt)
  - 13 maximum airspeed is .GT. 1 110 and .LE. 2 220 km/h (600 and 1 200 kt)
  - 14 maximum airspeed is more than 2 220 km/h (1 200 kt)
  - 15 not assigned.

*Note.*— “.LE.” means “less than or equal to” and “.GT.” means “greater than”.

3.1.2.8.2.3 *CC: Cross-link capability.* This 1-bit (7) downlink field shall indicate the ability of the transponder to support the cross-link capability, i.e. decode the contents of the DS field in an interrogation with UF equals 0 and respond with the contents of the specified GICB register in the corresponding reply with DF equals 16.

*Coding*

- 0 signifies that the transponder cannot support the cross-link capability
- 1 signifies that the transponder supports the cross-link capability.

3.1.2.8.3 *LONG AIR-AIR SURVEILLANCE, DOWNLINK FORMAT 16*

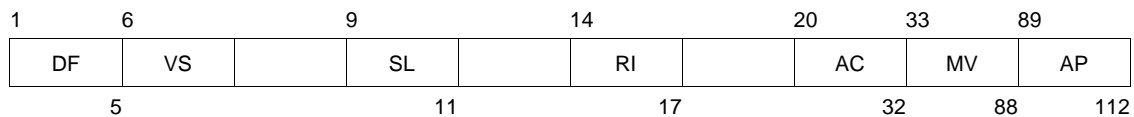

This reply shall be sent in response to an interrogation with UF equals 0 and RL equals 1. The format of this reply shall consist of these fields:

<i>Field</i>	<i>Reference</i>
DF downlink format	3.1.2.3.2.1.2
VS vertical status	3.1.2.8.2.1
spare — 2 bits	
SL sensitivity level, ACAS	4.3.8.4.2.5
spare — 2 bits	
RI reply information	3.1.2.8.2.2
spare — 2 bits	
AC altitude code	3.1.2.6.5.4
MV message, ACAS	3.1.2.8.3.1
AP address/parity	3.1.2.3.2.1.3

3.1.2.8.3.1 *MV: Message, ACAS.* This 56-bit (33-88) downlink field shall contain GICB information as requested in the DS field of the UF 0 interrogation that elicited the reply.

*Note.*— The MV field is also used by ACAS for air-air coordination (4.3.8.4.2.4).

## 3.1.2.8.4 AIR-AIR TRANSACTION PROTOCOL

*Note.*— Interrogation-reply coordination for the air-air formats follows the protocol outlined in Table 3-5 (3.1.2.4.1.3.2.2).

The most significant bit (bit 14) of the RI field of an air-air reply shall replicate the value of the AQ field (bit 14) received in an interrogation with UF equals 0.

If AQ equals 0 in the interrogation, the RI field of the reply shall contain the value 0 (no operating ACAS) or ACAS information as indicated in 3.1.2.8.2.2 and 4.3.8.4.1.2.

If AQ equals 1 in the interrogation, the RI field of the reply shall contain the maximum cruising true airspeed capability of the aircraft as defined in 3.1.2.8.2.2.

In response to a UF = 0 with RL = 1 and DS ≠ 0, the transponder shall reply with a DF = 16 reply in which the MV field shall contain the contents of the GICB register designated by the DS value. In response to a UF = 0 with RL = 1 and DS = 0, the transponder shall reply with a DF = 16 with an MV field of all zeros. Receipt of a UF = 0 with DS ≠ 0 but RL = 0 shall have no associated ACAS cross-link action, and the transponder shall reply as specified in 3.1.2.8.2.2.

## 3.1.2.8.5 ACQUISITION SQUITTER

*Note.*— SSR Mode S transponders transmit acquisition squitters (unsolicited downlink transmissions) to permit passive acquisition by interrogators with broad antenna beams, where active acquisition may be hindered by all-call synchronous garble. Examples of such interrogators are an airborne collision avoidance system and an airport surface surveillance system.

3.1.2.8.5.1 *Acquisition squitter format.* The format used for acquisition squitter transmissions shall be the all-call reply, (DF = 11) with II = 0.

3.1.2.8.5.2 *Acquisition squitter rate.* Acquisition squitter transmissions shall be emitted at random intervals that are uniformly distributed over the range from 0.8 to 1.2 seconds using a time quantization of no greater than 15 milliseconds relative to the previous acquisition squitter, with the following exceptions:

- a) the scheduled acquisition squitter shall be delayed if the transponder is in a transaction cycle (3.1.2.4.1);
- b) the acquisition squitter shall be delayed if an extended squitter is in process;
- c) the scheduled acquisition squitter shall be delayed if a mutual suppression interface is active (see Note 1 below); or
- d) acquisition squitters shall only be transmitted on the surface if the transponder is not reporting the surface position type of Mode S extended squitter.

An acquisition squitter shall not be interrupted by link transactions or mutual suppression activity after the squitter transmission has begun.

*Note 1.*— A mutual suppression system may be used to connect onboard equipment operating in the same frequency band in order to prevent mutual interference. Acquisition squitter action resumes as soon as practical after a mutual suppression interval.

*Note 2.*— The surface report type may be selected automatically by the aircraft or by commands from a squitter ground station (3.1.2.8.6.7).

3.1.2.8.5.3 *Acquisition squitter antenna selection.* Transponders operating with antenna diversity (3.1.2.10.4) shall transmit acquisition squitters as follows:

- a) when airborne (3.1.2.8.6.7), the transponder shall transmit acquisition squitters alternately from the two antennas; and
- b) when on the surface (3.1.2.8.6.7), the transponder shall transmit acquisition squitters under control of SAS (3.1.2.6.1.4.1 f)). In the absence of any SAS commands, use of the top antenna only shall be the default.

*Note.*— Acquisition squitters are not emitted on the surface if the transponder is reporting the surface type of extended squitter (3.1.2.8.6.4.3).

### 3.1.2.8.6 EXTENDED SQUITTER, DOWNLINK FORMAT 17

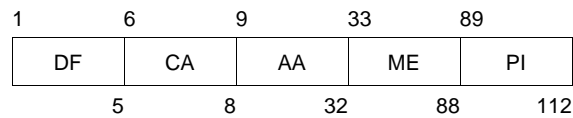

*Note.*— SSR Mode S transponders transmit extended squitters to support the broadcast of aircraft-derived position for surveillance purposes. The broadcast of this type of information is a form of automatic dependent surveillance (ADS) known as ADS-broadcast (ADS-B).

3.1.2.8.6.1 *Extended squitter format.* The format used for the extended squitter shall be a 112-bit downlink format (DF = 17) containing the following fields:

<i>Field</i>	<i>Reference</i>
DF downlink format	3.1.2.3.2.1.2
CA capability	3.1.2.5.2.2.1
AA address, announced	3.1.2.5.2.2.2
ME message, extended squitter	3.1.2.8.6.2
PI parity/interrogator identifier	3.1.2.3.2.1.4

The PI field shall be encoded with II equal to 0.

3.1.2.8.6.2 *ME: Message, extended squitter.* This 56-bit (33-88) downlink field in DF = 17 shall be used to transmit broadcast messages. Extended squitter shall be supported by registers 05, 06, 07, 08, 09, 0A {HEX} and 61-6F {HEX} and shall conform to either version 0 or version 1 message formats as described below:

- a) Version 0 ES message formats and related requirements are suitable for early implementation of extended squitter applications. Surveillance quality is reported by navigation uncertainty category (NUC), which can be an indication of either the accuracy or integrity of the navigation data used by ADS-B. However, there is no indication as to which of these, integrity or accuracy, the NUC value is providing an indication of.
- b) Version 1 ES message formats and related requirements apply to more advanced ADS-B applications. Surveillance accuracy and integrity are reported separately as navigation accuracy category (NAC), navigation integrity category (NIC) and surveillance integrity level (SIL). Version 1 ES formats also include provisions for enhanced reporting of status information.

*Note 1.*— The formats and update rates of each register are specified in the Technical Provisions for Mode S Services and Extended Squitter (Doc 9871).

*Note 2.— The formats for the two versions are interoperable. An extended squitter receiver can recognize and decode both version 0 and version 1 message formats.*

*Note 3.— Guidance material on transponder register formats and data sources is included in the Technical Provisions for Mode S Services and Extended Squitter (Doc 9871).*

### 3.1.2.8.6.3 Extended squitter types

3.1.2.8.6.3.1 *Airborne position squitter.* The airborne position extended squitter type shall use format DF = 17 with the contents of GICB register 05 {HEX} inserted in the ME field.

*Note.— A GICB request (3.1.2.6.11.2) containing RR equals 16 and DI equals 7 and RRS equals 5 will cause the resulting reply to contain the airborne position report in its MB field.*

3.1.2.8.6.3.1.1 *SSS, surveillance status subfield in ME.* The transponder shall report the surveillance status of the transponder in this 2-bit (38, 39) subfield of ME when ME contains an airborne position squitter report.

#### Coding

- 0 signifies no status information
- 1 signifies transponder reporting permanent alert condition (3.1.2.6.10.1.1.1)
- 2 signifies transponder reporting a temporary alert condition (3.1.2.6.10.1.1.2)
- 3 signifies transponder reporting SPI condition (3.1.2.6.10.1.3)

Codes 1 and 2 shall take precedence over code 3.

3.1.2.8.6.3.1.2 *ACS, altitude code subfield in ME.* Under control of ATS (3.1.2.8.6.3.1.3), the transponder shall report either navigation-derived altitude, or the barometric altitude code in this 12-bit (41-52) subfield of ME when ME contains an airborne position report. When barometric altitude is reported, the contents of the ACS shall be as specified for the 13-bit AC field (3.1.2.6.5.4) except that the M-bit (bit 26) shall be omitted.

3.1.2.8.6.3.1.3 *Control of ACS reporting.* Transponder reporting of altitude data in ACS shall depend on the altitude type subfield (ATS) as specified in 3.1.2.8.6.8.2. Transponder insertion of barometric altitude data in the ACS subfield shall take place when the ATS subfield has the value of ZERO. Transponder insertion of barometric altitude data in ACS shall be inhibited when ATS has the value 1.

3.1.2.8.6.3.2 *Surface position squitter.* The surface position extended squitter type shall use format DF = 17 with the contents of GICB register 06 {HEX} inserted in the ME field.

*Note.— A GICB request (3.1.2.6.11.2) containing RR equals 16 and DI equals 7 and RRS equals 6 will cause the resulting reply to contain the surface position report in its MB field.*

3.1.2.8.6.3.3 *Aircraft identification squitter.* The aircraft identification extended squitter type shall use format DF = 17 with the contents of GICB register 08 {HEX} inserted in the ME field.

*Note.— A GICB request (3.1.2.6.11.2) containing RR equals 16 and DI equals 7 and RRS equals 8 will cause the resulting reply to contain the aircraft identification report in its MB field.*

3.1.2.8.6.3.4 *Airborne velocity squitter.* The airborne velocity extended squitter type shall use format DF = 17 with the contents of GICB register 09 {HEX} inserted in the ME field.

*Note.— A GICB request (3.1.2.6.11.2) containing RR equals 16 and DI equals 7 and RRS equals 9 will cause the resulting reply to contain the airborne velocity report in its MB field.*

3.1.2.8.6.3.5 *Event-driven squitter.* The event-driven extended squitter type shall use format DF = 17 with the contents of GICB register 0A {HEX} inserted in the ME field.

*Note.*— A GICB request (3.1.2.6.11.2) containing RR equals 16 and DI equals 7 and RRS equals 10 will cause the resulting reply to contain the event-driven report in its MB field.

#### 3.1.2.8.6.4 *Extended squitter rate*

3.1.2.8.6.4.1 *Initialization.* At power up initialization, the transponder shall commence operation in a mode in which it broadcasts only acquisition squitters (3.1.2.8.5). The transponder shall initiate the broadcast of extended squitters for airborne position, surface position, airborne velocity and aircraft identification when data are inserted into transponder registers 05, 06, 09 and 08 {HEX}, respectively. This determination shall be made individually for each squitter type. When extended squitters are broadcast, transmission rates shall be as indicated in the following paragraphs. Acquisition squitters shall be reported in addition to extended squitters unless the acquisition squitter is inhibited (2.1.5.4). Acquisition squitters shall always be reported if position or velocity extended squitters are not reported.

*Note 1.*— This suppresses the transmission of extended squitters from aircraft that are unable to report position, velocity or identity. If input to the register for a squitter type stops for 60 seconds, broadcast of that extended squitter type will be discontinued until data insertion is resumed.

*Note 2.*— After timeout (3.1.2.8.6.6), this squitter type may contain an ME field of all zeroes.

3.1.2.8.6.4.2 *Airborne position squitter rate.* Airborne position squitter transmissions shall be emitted when the aircraft is airborne (3.1.2.8.6.7) at random intervals that are uniformly distributed over the range from 0.4 to 0.6 seconds using a time quantization of no greater than 15 milliseconds relative to the previous airborne position squitter, with the exceptions as specified in 3.1.2.8.6.4.7.

3.1.2.8.6.4.3 *Surface position squitter rate.* Surface position squitter transmissions shall be emitted when the aircraft is on the surface (3.1.2.8.6.7) using one of two rates depending upon whether the high or low squitter rate has been selected (3.1.2.8.6.9). When the high squitter rate has been selected, surface position squitters shall be emitted at random intervals that are uniformly distributed over the range from 0.4 to 0.6 seconds using a time quantization of no greater than 15 milliseconds relative to the previous surface position squitter (termed the high rate). When the low squitter rate has been selected, surface position squitters shall be emitted at random intervals that are uniformly distributed over the range of 4.8 to 5.2 seconds using a time quantization of no greater than 15 milliseconds relative to the previous surface position squitter (termed the low rate). Exceptions to these transmission rates are specified in 3.1.2.8.6.4.7.

3.1.2.8.6.4.4 *Aircraft identification squitter rate.* Aircraft identification squitter transmissions shall be emitted at random intervals that are uniformly distributed over the range of 4.8 to 5.2 seconds using a time quantization of no greater than 15 milliseconds relative to the previous identification squitter when the aircraft is reporting the airborne position squitter type, or when the aircraft is reporting the surface position squitter type and the high surface squitter rate has been selected. When the surface position squitter type is being reported at the low surface rate, the aircraft identification squitter shall be emitted at random intervals that are uniformly distributed over the range of 9.8 to 10.2 seconds using a time quantization of no greater than 15 milliseconds relative to the previous identification squitter. Exceptions to these transmission rates are specified in 3.1.2.8.6.4.7.

3.1.2.8.6.4.5 *Airborne velocity squitter rate.* Airborne velocity squitter transmissions shall be emitted when the aircraft is airborne (3.1.2.8.6.7) at random intervals that are uniformly distributed over the range from 0.4 to 0.6 seconds using a time quantization of no greater than 15 milliseconds relative to the previous airborne velocity squitter, with the exceptions as specified in 3.1.2.8.6.4.7.

3.1.2.8.6.4.6 *Event-driven squitter rate.* The event-driven squitter shall be transmitted once, each time that GICB register 0A {HEX} is loaded, while observing the delay conditions specified in 3.1.2.8.6.4.7. The maximum transmission rate for the event-driven squitter shall be limited by the transponder to twice per second. If a message is inserted in the event-driven register

and cannot be transmitted due to rate limiting, it shall be held and transmitted when the rate limiting condition has cleared. If a new message is received before transmission is permitted, it shall overwrite the earlier message.

*Note.*— *The squitter transmission rate and the duration of squitter transmissions is application-dependent. Choices made for each application must take into account interference considerations as shown in the Aeronautical Surveillance Manual (Doc 9924).*

3.1.2.8.6.4.7 *Delayed transmission.* Extended squitter transmission shall be delayed in the following circumstances:

- a) if the transponder is in a transaction cycle (3.1.2.4.1);
- b) if an acquisition or another type of extended squitter is in process; or
- c) if a mutual suppression interface is active.

The delayed squitter shall be transmitted as soon as the transponder becomes available.

3.1.2.8.6.5 *Extended squitter antenna selection.* Transponders operating with antenna diversity (3.1.2.10.4) shall transmit extended squitters as follows:

- a) when airborne (3.1.2.8.6.7), the transponder shall transmit each type of extended squitter alternately from the two antennas; and
- b) when on the surface (3.1.2.8.6.7), the transponder shall transmit extended squitters under control of SAS (3.1.2.6.1.4.1 f)).

In the absence of any SAS commands, use of the top antenna only shall be the default condition.

3.1.2.8.6.6 *Register time-out.* The transponder shall clear all 56-bits of the airborne position, surface position, squitter status and airborne velocity information transponder registers 05, 06, 07 and 09 {HEX} if these registers are not updated within two seconds of the previous update. This time-out shall be determined separately for each of these registers.

*Note 1.*— *Termination of extended squitter broadcast is specified in the Technical Provisions for Mode S Services and Extended Squitter (Doc 9871).*

*Note 2.*— *These registers are cleared to prevent the reporting of outdated position, velocity and squitter rate information.*

3.1.2.8.6.7 *Airborne/surface state determination.* Aircraft with an automatic means of determining on-the-ground conditions shall use this input to select whether to report the airborne or surface message types. Aircraft without such means shall report the airborne type messages, except as specified in Table 3-7. Use of this table shall only be applicable to aircraft that are equipped to provide data for radio altitude AND, as a minimum, airspeed OR ground speed. Otherwise, aircraft in the specified categories that are only equipped to provide data for airspeed and ground speed shall broadcast the surface format if:

airspeed < 50 knots AND ground speed < 50 knots

Aircraft with or without such automatic on-the-ground determination shall set and report the on-the-ground status (and therefore broadcast the surface type format) as commanded by control codes in TCS (3.1.2.6.1.4.1 f)). After time-out of the TCS commands, control of airborne/surface determination shall revert to the means described above.

*Note.*— *Extended squitter ground stations determine aircraft airborne or on-the-ground status by monitoring aircraft position, altitude and ground speed. Aircraft determined to be on the ground that are not reporting the on-the-ground status will be commanded to set and report the on-the-ground status via TCS (3.1.2.6.1.4.1 f)). The normal return to aircraft control of the vertical status is via a ground command to cancel the on-the-ground status. To guard against loss of communications after take-off, commands to set and report the on-the-ground status automatically time-out.*

3.1.2.8.6.8 *Squitter status reporting.* A GICB request (3.1.2.6.11.2) containing RR equals 16 and DI equals 7 and RRS equals 7 shall cause the resulting reply to contain the squitter status report in its MB field.

3.1.2.8.6.8.1 *TRS, transmission rate subfield in MB.* The transponder shall report the capability of the aircraft to automatically determine its surface squitter rate and its current squitter rate in this 2-bit (33, 34) subfield of MB.

*Coding*

- |   |  |
|---|--|
| 0 | signifies no capability to automatically determine surface squitter rate |
| 1 | signifies that the high surface squitter rate has been selected          |
| 2 | signifies that the low surface squitter rate has been selected           |
| 3 | unassigned   |

*Note 1.— High and low squitter rate is determined on board the aircraft.*

*Note 2.— The low rate is used when the aircraft is stationary and the high rate is used when the aircraft is moving. For details of how “moving” is determined, see the data format of register 07<sub>16</sub> in the Technical Provisions for Mode S Services and Extended Squitter (Doc 9871).*

3.1.2.8.6.8.2 *ATS, altitude type subfield in MB.* The transponder shall report the type of altitude being provided in the airborne position extended squitter in this 1-bit (35) subfield of MB when the reply contains the contents of transponder register 07 {HEX}.

*Coding*

- |   |   |
|---|---|
| 0 | signifies that barometric altitude shall be reported in the ACS (3.1.2.8.6.3.1.2) of transponder register 05 {HEX}.         |
| 1 | signifies that navigation-derived altitude shall be reported in the ACS (3.1.2.8.6.3.1.2) of transponder register 05 {HEX}. |

*Note.— Details of the contents of transponder registers 05 {HEX} and 07 {HEX} are shown in the Technical Provisions for Mode S Services and Extended Squitter (Doc 9871).*

3.1.2.8.6.9 *Surface squitter rate control.* Surface squitter rate shall be determined as follows:

- once per second the contents of the TRS shall be read. If the value of TRS is 0 or 1, the transponder shall transmit surface squitters at the high rate. If the value of TRS is 2, the transponder shall transmit surface squitters at the low rate;
- the squitter rate determined via TRS shall be subject to being overridden by commands received via RCS (3.1.2.6.1.4.1 f). RCS code 1 shall cause the transponder to squitter at the high rate for 60 seconds. RCS code 2 shall cause the transponder to squitter at the low rate for 60 seconds. These commands shall be able to be refreshed for a new 60 second period before time-out of the prior period; and
- after time-out and in the absence of RCS codes 1 and 2, control shall return to TRS.

3.1.2.8.6.10 *Latitude/longitude coding using compact position reporting (CPR).* Mode S extended squitter shall use compact position reporting (CPR) to encode latitude and longitude efficiently into messages.

*Note.— The method used to encode/decode CPR is specified in the Technical Provisions for Mode S Services and Extended Squitter (Doc 9871).*

3.1.2.8.6.11 *Data insertion.* When the transponder determines that it is time to emit an airborne position squitter, it shall insert the current value of the barometric altitude (unless inhibited by the ATS subfield, 3.1.2.8.6.8.2) and surveillance status into the appropriate fields of register 05 {HEX}. The contents of this register shall then be inserted into the ME field of DF = 17 and transmitted.

*Note.*— Insertion in this manner ensures that (1) the squitter contains the latest altitude and surveillance status, and (2) ground read-out of register 05 {HEX} will yield exactly the same information as the AC field of a Mode S surveillance reply.

### 3.1.2.8.7 EXTENDED SQUITTER/SUPPLEMENTARY, DOWNLINK FORMAT 18

10010	CF:3			PI:24
-------	------	--	--	-------

*Note 1.*— This format supports the broadcast of extended squitter ADS-B messages by non-transponder devices, i.e. they are not incorporated into a Mode S transponder. A separate format is used to clearly identify this non-transponder case to prevent ACAS II or extended squitter ground stations from attempting to interrogate these devices.

*Note 2.*— This format is also used for ground broadcast of ADS-B related services such as traffic information broadcast (TIS-B).

*Note 3.*— The format of the DF = 18 transmission is defined by the value of the CF field.

3.1.2.8.7.1 *ES supplementary format.* The format used for ES supplementary shall be a 112-bit downlink format (DF = 18) containing the following fields:

<i>Field</i>	<i>Reference</i>
DF downlink format	3.1.2.3.2.1.2
CF control field	3.1.2.8.7.2
PI parity/interrogator identifier	3.1.2.3.2.1.4

The PI field shall be encoded with II equal to zero.

3.1.2.8.7.2 *Control field.* This 3-bit (6-8) downlink field in DF = 18 shall be used to define the format of the 112-bit transmission as follows.

Code 0 = ADS-B ES/NT devices that report the ICAO 24-bit address in the AA field (3.1.2.8.7)

Code 1 = Reserved for ADS-B for ES/NT devices that use other addressing techniques in the AA field (3.1.2.8.7.3)

Code 2 = Fine format TIS-B message

Code 3 = Coarse format TIS-B message

Code 4 = Reserved for TIS-B management messages

Code 5 = TIS-B messages that relay ADS-B messages that use other addressing techniques in the AA field

Code 6 = ADS-B rebroadcast using the same type codes and message formats as defined for DF = 17 ADS-B messages

Code 7 = Reserved

*Note 1.*— Administrations may wish to make address assignments for ES/NT devices in addition to the 24-bit addresses allocated by ICAO (Annex 10, Volume III, Part I, Chapter 9) in order to increase the available number of 24-bit addresses.

*Note 2.*— These non-ICAO 24-bit addresses are not intended for international use.



## 3.1.2.8.7.3 ADS-B for extended squitter/non-transponder (ES/NT) devices

10010	CF=0	AA:24	ME:56	PI:24
-------	------	-------	-------	-------

3.1.2.8.7.3.1 *ES/NT format.* The format used for ES/NT shall be a 112-bit downlink format (DF = 18) containing the following fields:

<i>Field</i>	<i>Reference</i>
DF downlink format	3.1.2.3.2.1.2
CF control field = 0	3.1.2.8.7.2
AA address, announced	3.1.2.5.2.2.2
ME message, extended squitter	3.1.2.8.6.2
PI parity/interrogator identifier	3.1.2.3.2.1.4

The PI field shall be encoded with II equal to zero.

3.1.2.8.7.3.2 *ES/NT squitter types*

3.1.2.8.7.3.2.1 *Airborne position squitter.* The airborne position type ES/NT shall use format DF = 18 with the format for register 05 {HEX} as defined in 3.1.2.8.6.2 inserted in the ME field.

3.1.2.8.7.3.2.2 *Surface position squitter.* The surface position type ES/NT shall use format DF = 18 with the format for register 06 {HEX} as defined in 3.1.2.8.6.2 inserted in the ME field.

3.1.2.8.7.3.2.3 *Aircraft identification squitter.* The aircraft identification type ES/NT shall use format DF = 18 with the format for register 08 {HEX} as defined in 3.1.2.8.6.2 inserted in the ME field.

3.1.2.8.7.3.2.4 *Airborne velocity squitter.* The airborne velocity type ES/NT shall use format DF = 18 with the format for register 09 {HEX} as defined in 3.1.2.8.6.2 inserted in the ME field.

3.1.2.8.7.3.2.5 *Event-driven squitter.* The event-driven type ES/NT shall use format DF = 18 with the format for register 0A {HEX} as defined in 3.1.2.8.6.2 inserted in the ME field.

3.1.2.8.7.3.3 *ES/NT squitter rate*

3.1.2.8.7.3.3.1 *Initialization.* At power up initialization, the non-transponder device shall commence operation in a mode in which it does not broadcast any squitters. The non-transponder device shall initiate the broadcast of ES/NT squitters for airborne position, surface position, airborne velocity and aircraft identification when data are available for inclusion in the ME field of these squitter types. This determination shall be made individually for each squitter type. When ES/NT squitters are broadcast, transmission rates shall be as indicated in 3.1.2.8.6.4.2 to 3.1.2.8.6.4.6.

*Note 1.— This suppresses the transmission of extended squitters from aircraft that are unable to report position, velocity or identity. If input to the register for squitter types stops for 60 seconds, broadcast for this extended squitter type will cease until data insertion resumes, except for an ES/NT device operating on the surface (as specified for extended squitter Version 1 formats in the Technical Provisions for Mode S Services and Extended Squitter (Doc 9871).*

*Note 2.— After timeout (3.1.2.8.7.6) this squitter type may contain an ME field of all zeros.*

3.1.2.8.7.3.3.2 *Delayed transmission.* ES/NT squitter transmission shall be delayed if the non-transponder device is busy broadcasting one of the other squitter types.

3.1.2.8.7.3.3.2.1 The delayed squitter shall be transmitted as soon as the non-transponder device becomes available.

3.1.2.8.7.3.3.3 *ES/NT antenna selection.* Non-transponder devices operating with antenna diversity (3.1.2.10.4) shall transmit ES/NT squitters as follows:

- a) when airborne (3.1.2.8.6.7), the non-transponder device shall transmit each type of ES/NT squitter alternately from the two antennas; and
- b) when on the surface (3.1.2.8.6.7), the non-transponder device shall transmit ES/NT squitters using the top antenna.

3.1.2.8.7.3.3.4 *Register timeout.* The non-transponder device shall clear all 56-bits of the airborne position, surface position and velocity registers used for these messages if these registers are not updated within two seconds of the previous update. This timeout shall be determined separately for each of these registers.

*Note 1.— The termination of an extended squitter broadcast is specified in the Technical Provisions for Mode S Services and Extended Squitter (Doc 9871).*

*Note 2.— These registers are cleared to prevent the reporting of outdated position and velocity information.*

3.1.2.8.7.3.3.5 *Airborne/surface state determination.* Aircraft with an automatic means of determining the on-the-ground state shall use this input to select whether to report the airborne or surface message types except as specified in 3.1.2.6.10.3.1 and 3.1.2.8.6.7. Aircraft without such means shall report the airborne type message, except as specified in 3.1.2.8.6.7

3.1.2.8.7.3.3.6 *Surface squitter rate control.* Aircraft motion shall be determined once per second. The surface squitter rate shall be set according to the results of this determination.

*Note.— The algorithm to determine aircraft motion is specified in the definition of register 07<sub>16</sub> in the Technical Provisions for Mode S Services and Extended Squitter (Doc 9871).*

### 3.1.2.8.8 *EXTENDED SQUITTER MILITARY APPLICATION, DOWNLINK FORMAT 19*

10011	AF:3	
-------	------	--

*Note.— This format supports the broadcast of extended squitter ADS-B messages in support of military applications. A separate format is used to distinguish these extended squitters from the standard ADS-B message set broadcast using DF = 17 or 18.*

3.1.2.8.8.1 *Military format.* The format used for DF = 19 shall be a 112-bit downlink format containing the following fields:

<i>Field</i>	<i>Reference</i>
DF downlink format	3.1.2.3.2.1.2
AF control field	3.1.2.8.8.2

3.1.2.8.8.2 *Application field.* This 3-bit (6-8) downlink field in DF = 19 shall be used to define the format of the 112-bit transmission.

Code 0 to 7 = Reserved

### 3.1.2.8.9 *EXTENDED SQUITTER MAXIMUM TRANSMISSION RATE*

3.1.2.8.9.1 The maximum total number of extended squitters (DF = 17, 18 and 19) emitted by any extended squitter installation shall not exceed 6.2 per second, except as specified in 3.1.2.8.9.2.

3.1.2.8.9.2 For installations capable of emitting DF = 19 squitters and in accordance with 3.1.2.8.8, transmission rates for lower power DF = 19 squitters shall be limited to a peak of forty DF = 19 squitters per second, and thirty DF = 19 squitters per second averaged over 10 seconds, provided that the maximum total squitter power-rate product for the sum of full power DF = 17 squitters, full power DF = 18 squitters, full power DF = 19 squitters, and lower power DF = 19 squitters, is maintained at or below a level equivalent to the power sum of 6.2 full power squitters per second averaged over 10 seconds.

3.1.2.8.9.3 States shall ensure that the use of low power and higher rate DF = 19 operation (as per 3.1.2.8.9.2) is compliant with the following requirements:

- a) it is limited to formation or element lead aircraft engaged in formation flight, directing the messages toward wing and other lead aircraft through a directional antenna with a beamwidth of no more than 90 degrees; and
- b) the type of information contained in the DF = 19 message is limited to the same type of information in the DF = 17 message, that is, information for the sole purpose of safety-of-flight.

*Note.*— This low-power, higher squitter rate capability is intended for limited use by State aircraft in coordination with appropriate regulatory bodies.

3.1.2.8.9.4 All UF = 19 airborne interrogations shall be included in the interference control provisions of 4.3.2.2.2.2.

### 3.1.2.9 AIRCRAFT IDENTIFICATION PROTOCOL

3.1.2.9.1 *Aircraft identification reporting.* A ground-initiated Comm-B request (3.1.2.6.11.2) containing RR equals 18 and either DI does not equal 7 or DI equals 7 and RRS equals 0 shall cause the resulting reply to contain the aircraft identification in its MB field.

3.1.2.9.1.1 *AIS, aircraft identification subfield in MB.* The transponder shall report the aircraft identification in the 48-bit (41-88) AIS subfield of MB. The aircraft identification transmitted shall be that employed in the flight plan. When no flight plan is available, the registration marking of the aircraft shall be inserted in this subfield.

*Note.*— When the registration marking of the aircraft is used, it is classified as “fixed direct data” (3.1.2.10.5.1.1). When another type of aircraft identification is used, it is classified as “variable direct data” (3.1.2.10.5.1.3).

3.1.2.9.1.2 *Coding of the AIS subfield.* The AIS subfield shall be coded as follows:

33	41	47	53	59	65	71	77	83
BDS	Char. 1	Char. 2	Char. 3	Char. 4	Char. 5	Char. 6	Char. 7	Char. 8
40	46	52	58	64	70	76	82	88

*Note.*— Aircraft identification coding provides up to eight characters.

The BDS code for the aircraft identification message shall be BDS1 equals 2 (33-36) and BDS2 equals 0 (37-40).

Each character shall be coded as a 6-bit subset of the International Alphabet Number 5 (IA-5) as illustrated in Table 3-8. The character code shall be transmitted with the high order unit ( $b_6$ ) first and the reported aircraft identification shall be transmitted with its left-most character first. Characters shall be coded consecutively without intervening SPACE code. Any unused character spaces at the end of the subfield shall contain a SPACE character code.

3.1.2.9.1.3 *Aircraft identification capability report.* Transponders which respond to a ground-initiated request for aircraft identification shall report this capability in the data link capability report (3.1.2.6.10.2.2.2) by setting bit 33 of the MB subfield to 1.

3.1.2.9.1.4 *Change of aircraft identification.* If the aircraft identification reported in the AIS subfield is changed in flight, the transponder shall report the new identification to the ground by use of the Comm-B broadcast message protocol of 3.1.2.6.11.4 for BDS1 = 2 (33 - 36) and BDS2 = 0 (37 - 40). The transponder shall initiate, generate and announce the revised aircraft identification even if the interface providing flight identification is lost. The transponder shall ensure that the BDS code is set for the aircraft identification report in all cases, including a loss of the interface. In this latter case, bits 41 - 88 shall contain all ZEROS.

*Note.*— *The setting of the BDS code by the transponder ensures that a broadcast change of aircraft identification will contain the BDS code for all cases of flight identification failure (e.g. the loss of the interface providing flight identification).*

### 3.1.2.10 ESSENTIAL SYSTEM CHARACTERISTICS OF THE SSR MODE S TRANSPONDER

3.1.2.10.1 *Transponder sensitivity and dynamic range.* Transponder sensitivity shall be defined in terms of a given interrogation signal input level and a given percentage of corresponding replies. Only correct replies containing the required bit pattern for the interrogation received shall be counted. Given an interrogation that requires a reply according to 3.1.2.4, the minimum triggering level, MTL, shall be defined as the minimum input power level for 90 per cent reply-to-interrogation ratio. The MTL shall be  $-74$  dBm  $\pm 3$  dB. The reply-to-interrogation ratio of a Mode S transponder shall be:

- a) at least 99 per cent for signal input levels between 3 dB above MTL and  $-21$  dBm; and
- b) no more than 10 per cent at signal input levels below  $-81$  dBm.

*Note.*— *Transponder sensitivity and output power are described in this section in terms of signal level at the terminals of the antenna. This gives the designer freedom to arrange the installation, optimizing cable length and receiver-transmitter design, and does not exclude receiver and/or transmitter components from becoming an integral part of the antenna subassembly.*

#### 3.1.2.10.1.1 Reply ratio in the presence of interference

*Note.*— *The following paragraphs present measures of the performance of the Mode S transponder in the presence of interfering Mode A/C interrogation pulses and low-level in-band CW interference.*

3.1.2.10.1.1.1 *Reply ratio in the presence of an interfering pulse.* Given a Mode S interrogation which requires a reply (3.1.2.4), the reply ratio of a transponder shall be at least 95 per cent in the presence of an interfering Mode A/C interrogation pulse if the level of the interfering pulse is 6 dB or more below the signal level for Mode S input signal levels between  $-68$  dBm and  $-21$  dBm and the interfering pulse overlaps the  $P_6$  pulse of the Mode S interrogation anywhere after the sync phase reversal.

Under the same conditions, the reply ratio shall be at least 50 per cent if the interference pulse level is 3 dB or more below the signal level.

3.1.2.10.1.1.2 *Reply ratio in the presence of pulse pair interference.* Given an interrogation which requires a reply (3.1.2.4), the reply ratio of a transponder shall be at least 90 per cent in the presence of an interfering  $P_1 - P_2$  pulse pair if the level of the interfering pulse pair is 9 dB or more below signal level for input signal levels between  $-68$  dBm and  $-21$  dBm and the  $P_1$  pulse of the interfering pair occurs no earlier than the  $P_1$  pulse of the Mode S signal.

3.1.2.10.1.1.3 *Reply ratio in the presence of low level asynchronous interference.* For all received signals between  $-65$  dBm and  $-21$  dBm and given a Mode S interrogation that requires a reply according to 3.1.2.4 and if no lockout condition is in effect, the transponder shall reply correctly with at least 95 per cent reply ratio in the presence of asynchronous interference. Asynchronous interference shall be taken to be a single Mode A/C interrogation pulse occurring at all repetition rates up to 10 000 Hz at a level 12 dB or more below the level of the Mode S signal.

*Note.*— Such pulses may combine with the  $P_1$  and  $P_2$  pulses of the Mode S interrogation to form a valid Mode A/C-only all-call interrogation. The Mode S transponder does not respond to Mode A/C-only all-call interrogations. A preceding pulse may also combine with the  $P_2$  of the Mode S interrogation to form a valid Mode A or Mode C interrogation. However, the  $P_1$ – $P_2$  pair of the Mode S preamble takes precedence (3.1.2.4.1.1.1). The Mode S decoding process is independent of the Mode A/Mode C decoding process and the Mode S interrogation is accepted.

3.1.2.10.1.1.4 *Reply ratio in the presence of low-level in-band CW interference.* In the presence of non-coherent CW interference at a frequency of  $1\,030 \pm 0.2$  MHz at signal levels of 20 dB or more below the desired Mode A/C or Mode S interrogation signal level, the transponder shall reply correctly to at least 90 per cent of the interrogations.

#### 3.1.2.10.1.1.5 *Spurious response*

3.1.2.10.1.1.5.1 **Recommendation.**— *The response to signals not within the receiver pass band should be at least 60 dB below normal sensitivity.*

3.1.2.10.1.1.5.2 For equipment certified after 1 January 2011, the spurious Mode A/C reply ratio generated by low level Mode S interrogations shall be no more than:

- a) an average of 1 per cent in the input interrogation signal range between  $-81$  dBm and the Mode S MTL; and
- b) a maximum of 3 per cent at any given level in the input interrogation signal range between  $-81$  dBm and the Mode S MTL.

*Note.*— Failure to detect a low level Mode S interrogation can also result in the transponder decoding a three-pulse Mode A/C/S all-call interrogation. This would result in the transponder responding with a Mode S all-call ( $DF = 11$ ) reply. The above requirement will also control these  $DF = 11$  replies since it places a limit on the probability of failing to correctly detect the Mode S interrogation.

3.1.2.10.2 *Transponder peak pulse power.* The peak power of each pulse of a reply shall:

- a) not be less than 18.5 dBW for aircraft not capable of operating at altitudes exceeding 4 570 m (15 000 ft);
- b) not be less than 21.0 dBW for aircraft capable of operating above 4 570 m (15 000 ft);
- c) not be less than 21.0 dBW for aircraft with maximum cruising speed exceeding 324 km/h (175 kt); and
- d) not exceed 27.0 dBW.

3.1.2.10.2.1 *Inactive state transponder output power.* When the transponder is in the inactive state the peak pulse power at 1 090 MHz plus or minus 3 MHz shall not exceed  $-50$  dBm. The inactive state is defined to include the entire period between transmissions less 10-microsecond transition periods preceding the first pulse and following the last pulse of the transmission.

*Note.*— Inactive state transponder power is constrained in this way to ensure that an aircraft, when located as near as 185 m (0.1 NM) to a Mode A/C or Mode S interrogator, does not cause interference to that installation. In certain applications of Mode S, airborne collision avoidance for example, where a 1 090 MHz transmitter and receiver are in the same aircraft, it may be necessary to further constrain the inactive state transponder power.

#### 3.1.2.10.2.2 *Spurious emission radiation*

**Recommendation.**— *CW radiation should not exceed 70 dB below 1 watt.*

## 3.1.2.10.3 SPECIAL CHARACTERISTICS

## 3.1.2.10.3.1 Mode S side-lobe suppression

*Note.*— Side-lobe suppression for Mode S formats occurs when a  $P_5$  pulse overlays the location of the sync phase reversal of  $P_6$ , causing the transponder to fail to recognize the interrogation (3.1.2.4.1.1.3).

Given a Mode S interrogation that requires a reply, the transponder shall:

- a) at all signal levels between MTL +3 dB and –21 dBm, have a reply ratio of less than 10 per cent if the received amplitude of  $P_5$  exceeds the received amplitude of  $P_6$  by 3 dB or more;
- b) at all signal levels between MTL +3 dB and –21 dBm, have a reply ratio of at least 99 per cent if the received amplitude of  $P_6$  exceeds the received amplitude of  $P_5$  by 12 dB or more.

3.1.2.10.3.2 *Mode S dead time.* Dead time shall be defined as the time interval beginning at the end of a reply transmission and ending when the transponder has regained sensitivity to within 3 dB of MTL. Mode S transponders shall not have more than 125 microseconds' dead time.

3.1.2.10.3.3 *Mode S receiver desensitization.* The transponder's receiver shall be desensitized according to 3.1.1.7.7.1 on receipt of any pulse of more than 0.7 microseconds duration.

3.1.2.10.3.3.1 *Recovery from desensitization.* Recovery from desensitization shall begin at the trailing edge of each pulse of a received signal and shall occur at the rate prescribed in 3.1.1.7.7.2, provided that no reply or data transfer is made in response to the received signal.

## 3.1.2.10.3.4 Recovery after Mode S interrogations that do not elicit replies

## 3.1.2.10.3.4.1 Recovery after a single Mode S interrogation

3.1.2.10.3.4.1.1 The transponder shall recover sensitivity to within 3 dB of MTL no later than 128 microseconds after receipt of the sync phase reversal following a Mode S interrogation that is not accepted (3.1.2.4.1.2) or that is accepted but requires no reply.

3.1.2.10.3.4.1.2 **Recommendation.**— *The transponder should recover sensitivity to within 3 dB of MTL no later than 45 microseconds after receipt of the sync phase reversal following a Mode S interrogation that is not accepted (3.1.2.4.1.2) or that is accepted but requires no reply.*

3.1.2.10.3.4.1.3 All Mode S transponders installed on or after 1 January 1999 shall recover sensitivity to within 3 dB of MTL no later than 45 microseconds after receipt of the sync phase reversal following a Mode S interrogation that is not accepted (3.1.2.4.1.2) or that is accepted but requires no reply.

3.1.2.10.3.4.2 *Recovery after a Mode S Comm-C interrogation.* A Mode S transponder with Comm-C capability shall recover sensitivity to within 3 dB of MTL no later than 45 microseconds after receipt of the sync phase reversal following acceptance of a Comm-C interrogation for which no reply is required.

3.1.2.10.3.5 *Unwanted Mode S replies.* Mode S transponders shall not generate unwanted Mode S replies more often than once in 10 seconds. Installation in the aircraft shall be made in such a manner that this standard shall be achieved when all possible interfering equipments installed in the same aircraft are operating at maximum interference levels.

3.1.2.10.3.5.1 *Unwanted Mode S replies in the presence of low-level in-band CW interference.* In the presence of non-coherent CW interference at a frequency of  $1\ 030 \pm 0.2$  MHz and at signal levels of –60 dBm or less, and in the absence of

valid interrogation signals, Mode S transponders shall not generate unwanted Mode S replies more often than once per 10 seconds.

#### 3.1.2.10.3.6 Reply rate limiting

*Note.*— Reply rate limiting is prescribed separately for Modes A and C and for Mode S.

3.1.2.10.3.6.1 *Mode S reply rate limiting.* Reply rate limiting is not required for the Mode S formats of a transponder. If such limiting is incorporated for circuit protection, it shall permit the minimum reply rates required in 3.1.2.10.3.7.2 and 3.1.2.10.3.7.3.

3.1.2.10.3.6.2 *Modes A and C reply rate limiting.* Reply rate limiting for Modes A and C shall be effected according to 3.1.1.7.9.1. The prescribed sensitivity reduction (3.1.1.7.9.2) shall not affect the Mode S performance of the transponder.

#### 3.1.2.10.3.7 Minimum reply rate capability, Modes A, C and S

3.1.2.10.3.7.1 All reply rates specified in 3.1.2.10.3.7 shall be in addition to any squitter transmissions that the transponder is required to make.

3.1.2.10.3.7.2 *Minimum reply rate capability, Modes A and C.* The minimum reply rate capability for Modes A and C shall be in accordance with 3.1.1.7.9.

3.1.2.10.3.7.3 *Minimum reply rate capability, Mode S.* A transponder capable of transmitting only short Mode S replies shall be able to generate replies at the following rates:

- 50 Mode S replies in any 1-second interval
- 18 Mode S replies in a 100-millisecond interval
- 8 Mode S replies in a 25-millisecond interval
- 4 Mode S replies in a 1.6-millisecond interval

In addition to any downlink ELM transmissions, a level 2, 3 or 4 transponder shall be able to generate as long replies at least:

- 16 of 50 Mode S replies in any 1-second interval
- 6 of 18 Mode S replies in a 100-millisecond interval
- 4 of 8 Mode S replies in a 25-millisecond interval
- 2 of 4 Mode S replies in a 1.6-millisecond interval

In addition to downlink ELM transmissions, a level 5 transponder shall be able to generate as long replies at least:

- 24 of 50 Mode S replies in any 1-second interval
- 9 of 18 Mode S replies in a 100-millisecond interval
- 6 of 8 Mode S replies in a 25-millisecond interval
- 2 of 4 Mode S replies in a 1.6-millisecond interval

In addition, a transponder within an ACAS installation shall be able to generate as ACAS coordination replies at least 3 of 50 Mode S replies in any 1-second interval.

#### 3.1.2.10.3.7.4 Minimum Mode S ELM peak reply rate

*Note 1.*— When a downlink ELM is initialized (3.1.2.7.7.1), the Mode S transponder announces the length (in segments) of the waiting message. The transponder must be able to transmit this number of segments, plus an additional margin to make up for missed replies, during the beam dwell of the ground interrogator.

At least once every second a Mode S transponder equipped for ELM downlink operation shall be capable of transmitting in a 25-millisecond interval, at least 25 per cent more segments than have been announced in the initialization (3.1.2.7.7.1). The minimum length downlink ELM capability for level 4 and 5 transponders shall be as specified in 3.1.2.10.5.2.2.2.

*Note 2.— A transponder capable of processing the maximum length downlink ELM (16 segments) is therefore required to be able to transmit 20 long replies under the above conditions. Level 4 transponders may be built which process less than the maximum message length. These transponders cannot initialize a message length that exceeds their transmitter capability. For example, a transponder that can transmit at most 10 long replies under the above conditions can never announce a message of more than 8 segments.*

#### 3.1.2.10.3.8 Reply delay and jitter

*Note.— After an interrogation has been accepted and if a reply is required, this reply transmission begins after a fixed delay needed to carry out the protocols. Different values for this delay are assigned for Modes A and C, for Mode S and for Modes A/C/S all-call replies.*

3.1.2.10.3.8.1 *Reply delay and jitter for Modes A and C.* The reply delay and jitter for Modes A and C transactions shall be as prescribed in 3.1.1.7.10.

3.1.2.10.3.8.2 *Reply delay and jitter for Mode S.* For all input signal levels between MTL and  $-21$  dBm, the leading edge of the first preamble pulse of the reply (3.1.2.2.5.1.1) shall occur 128 plus or minus 0.25 microsecond after the sync phase reversal (3.1.2.1.5.2.2) of the received  $P_6$ . The jitter of the reply delay shall not exceed 0.08 microsecond, peak (99.9 percentile).

3.1.2.10.3.8.3 *Reply delay and jitter for Modes A/C/S all call.* For all input signal levels between MTL +3 dB and  $-21$  dBm the leading edge of the first preamble pulse of the reply (3.1.2.2.5.1.1) shall occur 128 plus or minus 0.5 microseconds after the leading edge of the  $P_4$  pulse of the interrogation (3.1.2.1.5.1.1). Jitter shall not exceed 0.1 microsecond, peak (99.9 percentile).

*Note.— A peak jitter of 0.1 microsecond is consistent with the jitter prescribed in 3.1.1.7.10.*

3.1.2.10.3.9 *Timers.* Duration and features of timers shall be as shown in Table 3-9. All timers shall be capable of being restarted. On receipt of any start command, they shall run for their specified times. This shall occur regardless of whether they are in the running or the non-running state at the time that the start command is received. A command to reset a timer shall cause the timer to stop running and to return to its initial state in preparation for a subsequent start command.

3.1.2.10.3.10 *Inhibition of replies.* Replies to Mode A/C/S all-call and Mode S-only all-call interrogations shall always be inhibited when the aircraft declares the on-the-ground state. It shall not be possible to inhibit replies to discretely addressed Mode S interrogations regardless of whether the aircraft is airborne or on the ground.

3.1.2.10.3.10.1 **Recommendation.**— *Aircraft should provide means to determine the on-the-ground state automatically and provide that information to the transponder.*

3.1.2.10.3.10.2 **Recommendation.**— *Mode A/C replies should be inhibited when the aircraft is on the ground to prevent interference when in close proximity to an interrogator or other aircraft.*

*Note.— Mode S discretely addressed interrogations do not give rise to such interference and may be required for data link communications with aircraft on the airport surface. Acquisition squitter transmissions may be used for passive surveillance of aircraft on the airport surface.*

3.1.2.10.3.10.3 *Inhibition of squitter transmissions.* It shall not be possible to inhibit extended squitter transmissions except as specified in 3.1.2.8.6 or acquisition squitter transmissions except as specified in 3.1.2.8.5 regardless of whether the aircraft is airborne or on the ground.



*Note.*— For additional information on squitter inhibition see the Aeronautical Surveillance Manual (Doc 9924).

3.1.2.10.4 *Transponder antenna system and diversity operation.* Mode S transponders equipped for diversity operation shall have two RF ports for operation with two antennas, one antenna on the top and the other on the bottom of the aircraft's fuselage. The received signal from one of the antennas shall be selected for acceptance and the reply shall be transmitted from the selected antenna only.

3.1.2.10.4.1 *Radiation pattern.* The radiation pattern of Mode S antennas when installed on an aircraft shall be nominally equivalent to that of a quarter-wave monopole on a ground plane.

*Note.*— *Transponder antennas designed to increase gain at the expense of vertical beamwidth are undesirable because of their poor performance during turns.*

3.1.2.10.4.2 *Antenna location.* The top and bottom antennas shall be mounted as near as possible to the centre line of the fuselage. Antennas shall be located so as to minimize obstruction to their fields in the horizontal plane.

3.1.2.10.4.2.1 **Recommendation.**— *The horizontal distance between the top and bottom antennas should not be greater than 7.6 m (25 ft).*

*Note.*— *This recommendation is intended to support the operation of any diversity transponder (including cables) with any diversity antenna installation and still satisfy the requirement of 3.1.2.10.4.5.*

3.1.2.10.4.3 *Antenna selection.* Mode S transponders equipped for diversity operation shall have the capability to evaluate a pulse sequence simultaneously received on both antenna channels to determine individually for each channel if the  $P_1$  pulse and the  $P_2$  pulse of a Mode S interrogation preamble meet the requirements for a Mode S interrogation as defined in 3.1.2.1 and if the  $P_1$  pulse and the  $P_3$  pulse of a Mode A, Mode C or intermode interrogation meet the requirements for Mode A and Mode C interrogations as defined in 3.1.1.

*Note.*— *Transponders equipped for diversity operation may optionally have the capability to evaluate additional characteristics of the received pulses of the interrogations in making a diversity channel selection. The transponder may as an option evaluate a complete Mode S interrogation simultaneously received on both channels to determine individually for each channel if the interrogation meets the requirements for Mode S interrogation acceptance as defined in 3.1.2.4.1.2.3.*

3.1.2.10.4.3.1 If the two channels simultaneously receive at least a  $P_1 - P_2$  pulse pair that meets the requirements for a Mode S interrogation, or a  $P_1 - P_3$  pulse pair that meets the requirements for a Mode A or Mode C interrogation, or if the two channels simultaneously accept a complete interrogation, the antenna at which the signal strength is greater shall be selected for the reception of the remainder (if any) of the interrogation and for the transmission of the reply.

3.1.2.10.4.3.2 If only one channel receives a pulse pair that meets the requirements for an interrogation, or if only one channel accepts an interrogation, the antenna associated with that channel shall be selected regardless of received signal strength.

3.1.2.10.4.3.3 *Selection threshold.* If antenna selection is based on signal level, it shall be carried out at all signal levels between MTL and  $-21$  dBm.

*Note.*— *Either antenna may be selected if the difference in signal level is less than 3 dB.*

3.1.2.10.4.3.4 *Received signal delay tolerance.* If an interrogation is received at one antenna 0.125 microsecond or less in advance of reception at the other antenna, the interrogations shall be considered to be simultaneous interrogations, and the above antenna selection criteria applied. If an accepted interrogation is received at either antenna 0.375 microsecond or more in advance of reception at the other antenna, the antenna selected for the reply shall be that which received the earlier interrogation. If the relative time of receipt is between 0.125 and 0.375 microsecond, the transponder shall select the antenna for reply either on the basis of the simultaneous interrogation criteria or on the basis of the earlier time of arrival.

3.1.2.10.4.4 *Diversity transmission channel isolation.* The peak RF power transmitted from the selected antenna shall exceed the power transmitted from the non-selected antenna by at least 20 dB.

3.1.2.10.4.5 *Reply delay of diversity transponders.* The total two-way transmission difference in mean reply delay between the two antenna channels (including the differential delay caused by transponder-to-antenna cables and the horizontal distance along the aircraft centre line between the two antennas) shall not exceed 0.13 microsecond for interrogations of equal amplitude. This requirement shall hold for interrogation signal strengths between MTL +3 dB and -21 dBm. The jitter requirements on each individual channel shall remain as specified for non-diversity transponders.

*Note.*— This requirement limits apparent jitter caused by antenna switching and by cable delay differences.

### 3.1.2.10.5 DATA PROCESSING AND INTERFACES

3.1.2.10.5.1 *Direct data.* Direct data shall be those which are required for the surveillance protocol of the Mode S system.

3.1.2.10.5.1.1 *Fixed direct data.* Fixed direct data are data from the aircraft which do not change in flight and shall be:

- a) the aircraft address (3.1.2.4.1.2.3.1.1 and 3.1.2.5.2.2.2);
- b) the maximum airspeed (3.1.2.8.2.2); and
- c) the registration marking if used for flight identification (3.1.2.9.1.1).

3.1.2.10.5.1.2 *Interfaces for fixed direct data*

**Recommendation.**— *Interfaces from the transponder to the aircraft should be designed such that the values of the fixed direct data become a function of the aircraft installation rather than of the transponder configuration.*

*Note.*— *The intent of this recommendation is to encourage an interface technique which permits transponder exchange without manipulation of the transponder itself for setting the fixed direct data.*

3.1.2.10.5.1.3 *Variable direct data.* Variable direct data are data from the aircraft which can change in flight and shall be:

- a) the Mode C altitude code (3.1.2.6.5.4);
- b) the Mode A identity code (3.1.2.6.7.1);
- c) the on-the-ground condition (3.1.2.5.2.2.1, 3.1.2.6.5.1 and 3.1.2.8.2.1);
- d) the aircraft identification if different from the registration marking (3.1.2.9.1.1); and
- e) the SPI condition (3.1.2.6.10.1.3).

3.1.2.10.5.1.4 *Interfaces for variable direct data.* A means shall be provided for the Mode A identity code, the SPI condition and, for transponders of Level 2 and above, the aircraft identification to be inserted by the pilot via a variable data interface.

Interfaces shall be included to accept the pressure-altitude and on-the-ground coding.

*Note.*— *A specific interface design for the variable direct data is not prescribed.*

3.1.2.10.5.2 *Indirect data*

*Note.*— *Indirect data are those which pass through the transponder in either direction but which do not affect the surveillance function.*

If origins and/or destinations of indirect data are not within the transponder's enclosure, interfaces shall be used for the necessary connections.

3.1.2.10.5.2.1 *The function of interfaces*

*Note.*— *Indirect data interfaces for standard transactions serve interrogations which require a reply and the broadcast function. Indirect data interfaces for ELM serve that system and require buffering and protocol circuitry within the transponder. Interface ports can be separate for each direction and for each service or can be combined in any manner.*

3.1.2.10.5.2.1.1 *Uplink standard length transaction interface.* The uplink standard length transaction interface shall transfer all bits of accepted interrogations, (with the possible exception of the AP field), except for UF = 0, 11 or 16.

*Note.*— *AP can also be transferred to aid in integrity implementation.*

3.1.2.10.5.2.1.2 *Downlink standard length transaction interface.* A transponder which transmits information originating in a peripheral device shall be able to receive bits or bit patterns for insertion at appropriate locations within the transmission. These locations shall not include those into which bit patterns generated internally by the transponder are inserted, nor the AP field of the reply. A transponder which transmits information using the Comm-B format shall have immediate access to requested data in the sense that the transponder shall respond to an interrogation with data requested by that interrogation.

*Note.*— *This requirement may be met in two ways:*

- a) *the transponder may have provisions for internal data and protocol buffering;*
- b) *the transponder may employ a "real time" interface which operates such that uplink data leave the transponder before the corresponding reply is generated and downlink data enter the transponder in time to be incorporated in the reply.*

3.1.2.10.5.2.1.3 *Extended length message interface*

*Note.*— *The ELM interface extracts from, and enters into, the transponder the data exchanged between air and ground by means of the ELM protocol (3.1.2.7).*

3.1.2.10.5.2.2 *Indirect data transaction rates*

3.1.2.10.5.2.2.1 *Standard length transactions.* A transponder equipped for information transfer to and from external devices shall be capable of processing the data of at least as many replies as prescribed for minimum reply rates in 3.1.2.10.3.7.2 and uplink data from interrogations being delivered at a rate of at least:

- 50 long interrogations in any 1-second interval
- 18 long interrogations in a 100-millisecond interval
- 8 long interrogations in a 25-millisecond interval
- 4 long interrogations in a 1.6-millisecond interval.

*Note 1.*— *A transponder capable of reply rates higher than the minimum of 3.1.2.10.3.7.2 need not accept long interrogations after reaching the uplink data processing limits above.*

*Note 2.*— *The Mode S reply is the sole means of acknowledging receipt of the data content of a Mode S interrogation. Thus, if the transponder is capable of replying to an interrogation, the Mode S installation must be capable of accepting the*

data contained in that interrogation regardless of the timing between it and other accepted interrogations. Overlapping Mode S beams from several interrogators could lead to the requirement for considerable data processing and buffering. The minimum described here reduces data processing to a realistic level and the non-acceptance provision provides for notification to the interrogator that data will temporarily not be accepted.

3.1.2.10.5.2.2.2 *Extended length transactions.* Level 3 (2.1.5.1.3) and level 4 (2.1.5.1.4) transponders shall be able to transfer data from at least four complete sixteen segment uplink ELMs (3.1.2.7.4) in any four second interval. A level 5 transponder (2.1.5.1.5) shall be able to transfer the data from at least four complete sixteen segment uplink ELMs in any one second interval and shall be capable of accepting at least two complete sixteen segment uplink ELMs with the same II code in a 250 millisecond interval. A level 4 transponder shall be able to transmit at least one four-segment downlink ELM (3.1.2.7.7 and 3.1.2.10.3.7.3) in any one second interval. A level 5 transponder shall be able to transmit at least one sixteen segment downlink ELM in any one second interval.

3.1.2.10.5.2.2.2.1 **Recommendation.**— *Level 3 and level 4 transponders should be able to accept at least two complete sixteen segment uplink ELMs in a 250 millisecond interval.*

### 3.1.2.10.5.2.3 *Data formats for standard length transactions and required downlink aircraft parameters (DAPs)*

3.1.2.10.5.2.3.1 All level 2 and above transponders shall support the following registers:

- the capability reports (3.1.2.6.10.2);
- the aircraft identification protocol register 20 {HEX} (3.1.2.9); and
- for ACAS-equipped aircraft, the active resolution advisory register 30 {HEX} (4.3.8.4.2.2).

3.1.2.10.5.2.3.2 Where required, DAPs shall be supported by the registers listed in Table 3-10. The formats and minimum update rates of transponder registers shall be implemented consistently to ensure interoperability.

3.1.2.10.5.2.3.3 The downlink standard length transaction interface shall deliver downlink aircraft parameters (DAPs) to the transponder which makes them available to the ground. Each DAP shall be packed into the Comm-B format ('MB' field) and can be extracted using either the ground-initiated Comm-B (GICB) protocol, or using MSP downlink channel 3 via the dataflash application.

*Note.*— *The formats and update rates of each register and the dataflash application are specified in the Technical Provisions for Mode S Services and Extended Squitter (Doc 9871).*

3.1.2.10.5.3 *Integrity of data content transfer.* A transponder which employs data interfaces shall include sufficient protection to ensure error rates of less than one error in  $10^3$  messages and less than one undetected error in  $10^7$  112-bit transmissions in both directions between the antenna and each interface port.

3.1.2.10.5.4 *Message cancellation.* The downlink standard length transaction interface and the extended length message interface shall include the capability to cancel a message sent to the transponder for delivery to the ground, but whose delivery cycle has not been completed (i.e. a closeout has not been accomplished by a ground interrogator).

*Note.*— *One example of the need for this capability is to cancel a message if delivery is attempted when the aircraft is not within coverage of a Mode S ground station. The message must then be cancelled to prevent it from being read and interpreted as a current message when the aircraft re-enters Mode S airspace.*

3.1.2.10.5.5 *Air-directed messages.* The transfer of this type of message requires all of the actions indicated in 3.1.2.10.5.4 plus the transfer to the transponder of the interrogator identifier of the site that is to receive the message.

## 3.1.2.11 ESSENTIAL SYSTEM CHARACTERISTICS OF THE GROUND INTERROGATOR

*Note.*— To ensure that Mode S interrogator action is not detrimental to Mode A/C interrogators, performance limits exist for Mode S interrogators.

3.1.2.11.1 *Interrogation repetition rates.* Mode S interrogators shall use the lowest practicable interrogation repetition rates for all interrogation modes.

*Note.*— Accurate azimuth data at low interrogation rates can be obtained with monopulse techniques.

3.1.2.11.1.1 *All-call interrogation repetition rate.* The interrogation repetition rate for the Mode A/C/S all-call, used for acquisition, shall be less than 250 per second. This rate shall also apply to the paired Mode S-only and Mode A/C-only all-call interrogations used for acquisition in the multisite mode.

3.1.2.11.1.2 *Interrogation repetition rate to a single aircraft*

3.1.2.11.1.2.1 *Interrogations requiring a reply.* Mode S interrogations requiring a reply shall not be transmitted to a single aircraft at intervals shorter than 400 microseconds.

3.1.2.11.1.2.2 *Uplink ELM interrogations.* The minimum time between the beginning of successive Comm-C interrogations shall be 50 microseconds.

3.1.2.11.1.3 *Transmission rate for selective interrogations*

3.1.2.11.1.3.1 For all Mode S interrogators, the transmission rate for selective interrogations shall be:

- a) less than 2 400 per second averaged over a 40-millisecond interval; and
- b) less than 480 into any 3-degree sector averaged over a 1-second interval.

3.1.2.11.1.3.2 Additionally, for a Mode S interrogator that has overlapping coverage with the sidelobes of any other Mode S interrogator, the transmission rate for selective interrogations shall be:

- a) less than 1 200 per second averaged over a 4-second interval; and
- b) less than 1 800 per second averaged over a 1-second interval.

*Note.*— Typical minimum distance to ensure sidelobe separation between interrogators is 35 km.

3.1.2.11.2 *INTERROGATOR-EFFECTIVE RADIATED POWER*

**Recommendation.**— The effective radiated power of all interrogation pulses should be minimized as described in 3.1.1.8.2.

3.1.2.11.3 *Inactive-state interrogator output power.* When the interrogator transmitter is not transmitting an interrogation, its output shall not exceed  $-5$  dBm effective radiated power at any frequency between 960 MHz and 1 215 MHz.

*Note.*— This constraint ensures that aircraft flying near the interrogator (as close as 1.85 km (1 NM)) will not receive interference that would prevent them from being tracked by another interrogator. In certain instances even smaller interrogator-to-aircraft distances are of significance, for example if Mode S surveillance on the airport surface is used. In such cases a further restraint on inactive state interrogator output power may be necessary.

3.1.2.11.3.1 *Spurious emission radiation*

**Recommendation.**— *CW radiation should not exceed 76 dB below 1 watt.*

3.1.2.11.4 *Tolerances on transmitted signals.* In order that the signal-in-space be received by the transponder as described in 3.1.2.1, the tolerances on the transmitted signal shall be as summarized in Table 3-11.

3.1.2.11.5 *SPURIOUS RESPONSE*

**Recommendation.**— *The response to signals not within the passband should be at least 60 dB below normal sensitivity.*

3.1.2.11.6 *Lockout coordination.* A Mode S interrogator shall not be operated using all-call lockout until coordination has been achieved with all other operating Mode S interrogators having any overlapping coverage volume in order to ensure that no interrogator can be denied the acquisition of Mode S-equipped aircraft.

*Note.*— *This coordination may be via ground network or by the allocation of interrogator identifier (II) codes and will involve regional agreements where coverage overlaps international boundaries.*

3.1.2.11.7 *MOBILE INTERROGATORS*

**Recommendation.**— *Mobile interrogators should acquire, whenever possible, Mode S aircraft through the reception of squitters.*

*Note.*— *Passive squitter acquisition reduces channel loading and can be accomplished without the need for coordination.*

## TABLES FOR CHAPTER 3

Table 3-1. Pulse shapes — Mode S and intermode interrogations

Pulse	Duration	Duration tolerance	(Rise time)		(Decay time)	
			Min.	Max.	Min.	Max.
$P_1, P_2, P_3, P_5$	0.8	±0.1	0.05	0.1	0.05	0.2
$P_4$ (short)	0.8	±0.1	0.05	0.1	0.05	0.2
$P_4$ (long)	1.6	±0.1	0.05	0.1	0.05	0.2
$P_6$ (short)	16.25	±0.25	0.05	0.1	0.05	0.2
$P_6$ (long)	30.25	±0.25	0.05	0.1	0.05	0.2
$S_I$	0.8	±0.1	0.05	0.1	0.05	0.2

Table 3-2. Pulse shapes — Mode S replies

Pulse duration	Duration tolerance	(Rise time)		(Decay time)	
		Min.	Max.	Min.	Max.
0.5	±0.05	0.05	0.1	0.05	0.2
1.0	±0.05	0.05	0.1	0.05	0.2

Table 3-3. Field definitions

<i>Field</i>		<i>Format</i>		<i>Reference</i>
<i>Designator</i>	<i>Function</i>	<i>UF</i>	<i>DF</i>	
AA	Address announced		11, 17, 18	3.1.2.5.2.2.2
AC	Altitude code		4, 20	3.1.2.6.5.4
AF	Application field		19	3.1.2.8.8.2
AP	Address/parity	All	0, 4, 5, 16, 20, 21, 24	3.1.2.3.2.1.3
AQ	Acquisition	0		3.1.2.8.1.1
CA	Capability		11, 17	3.1.2.5.2.2.1
CC	Cross-link capability		0	3.1.2.8.2.3
CF	Control field		18	3.1.2.8.7.2
CL	Code label	11		3.1.2.5.2.1.3
DF	Downlink format		All	3.1.2.3.2.1.2
DI	Designator identification	4, 5, 20, 21		3.1.2.6.1.3
DR	Downlink request		4, 5, 20, 21	3.1.2.6.5.2
DS	Data selector	0		3.1.2.8.1.3
FS	Flight status		4, 5, 20, 21	3.1.2.6.5.1
IC	Interrogator code	11		3.1.2.5.2.1.2
ID	Identity		5, 21	3.1.2.6.7.1
KE	Control, ELM		24	3.1.2.7.3.1
MA	Message, Comm-A	20, 21		3.1.2.6.2.1
MB	Message, Comm-B		20, 21	3.1.2.6.6.1
MC	Message, Comm-C	24		3.1.2.7.1.3
MD	Message, Comm-D		24	3.1.2.7.3.3
ME	Message, extended squitter		17, 18	3.1.2.8.6.2
MU	Message, ACAS	16		4.3.8.4.2.3
MV	Message, ACAS		16	3.1.2.8.3.1, 4.3.8.4.2.4
NC	Number of C-segment	24		3.1.2.7.1.2
ND	Number of D-segment		24	3.1.2.7.3.2
PC	Protocol	4, 5, 20, 21		3.1.2.6.1.1
PI	Parity/interrogator identifier		11, 17, 18	3.1.2.3.2.1.4
PR	Probability of reply	11		3.1.2.5.2.1.1
RC	Reply control	24		3.1.2.7.1.1
RI	Reply information		0	3.1.2.8.2.2
RL	Reply length	0		3.1.2.8.1.2
RR	Reply request	4, 5, 20, 21		3.1.2.6.1.2
SD	Special designator	4, 5, 20, 21		3.1.2.6.1.4
SL	Sensitivity Level (ACAS)		0, 16	4.3.8.4.2.5
UF	Uplink format	All		3.1.2.3.2.1.1
UM	Utility message		4, 5, 20, 21	3.1.2.6.5.3
VS	Vertical status		0	3.1.2.8.2.1

Table 3-4. Subfield definitions

<i>Subfield</i>			
<i>Designator</i>	<i>Function</i>	<i>Field</i>	<i>Reference</i>
ACS	Altitude code subfield	ME	3.1.2.8.6.3.1.2
AIS	Aircraft identification subfield	MB	3.1.2.9.1.1
ATS	Altitude type subfield	MB	3.1.2.8.6.8.2
BDS 1	Comm-B data selector subfield 1	MB	3.1.2.6.11.2.1
BDS 2	Comm-B data selector subfield 2	MB	3.1.2.6.11.2.1
IDS	Identifier designator subfield	UM	3.1.2.6.5.3.1
IIS	Interrogator identifier subfield	SD	3.1.2.6.1.4.1 a)
		UM	3.1.2.6.5.3.1
LOS	Lockout subfield	SD	3.1.2.6.1.4.1 d)
LSS	Lockout surveillance subfield	SD	3.1.2.6.1.4.1 g)
MBS	Multisite Comm-B subfield	SD	3.1.2.6.1.4.1 c)
MES	Multisite ELM subfield	SD	3.1.2.6.1.4.1 c)
RCS	Rate control subfield	SD	3.1.2.6.1.4.1 f)
RRS	Reply request subfield	SD	3.1.2.6.1.4.1 e) and g)
RSS	Reservation status subfield	SD	3.1.2.6.1.4.1 c)
SAS	Surface antenna subfield	SD	3.1.2.6.1.4.1 f)
SCS	Squitter capability subfield	MB	3.1.2.6.10.2.2.1
SIC	Surveillance identifier capability	MB	3.1.2.6.10.2.2.1
SIS	Surveillance identifier subfield	SD	3.1.2.6.1.4.1 g)
SRS	Segment request subfield	MC	3.1.2.7.7.2.1
SSS	Surveillance status subfield	ME	3.1.2.8.6.3.1.1
TAS	Transmission acknowledgement subfield	MD	3.1.2.7.4.2.6
TCS	Type control subfield	SD	3.1.2.6.1.4.1 f)
TMS	Tactical message subfield	SD	3.1.2.6.1.4.1 d)
TRS	Transmission rate subfield	MB	3.1.2.8.6.8.1

Table 3-5. Interrogation — reply protocol summary

<i>Interrogation UF</i>	<i>Special conditions</i>	<i>Reply DF</i>
0	RL (3.1.2.8.1.2) equals 0	0
	RL (3.1.2.8.1.2) equals 1	16
4	RR (3.1.2.6.1.2) less than 16	4
	RR (3.1.2.6.1.2) equal to or greater than 16	20
5	RR (3.1.2.6.1.2) less than 16	5
	RR (3.1.2.6.1.2) equal to or greater than 16	21
11	Transponder locked out to interrogator code, IC (3.1.2.5.2.1.2)	No reply
	Stochastic reply test fails (3.1.2.5.4)	No reply
	Otherwise	11



20	RR (3.1.2.6.1.2) less than 16	4
	RR (3.1.2.6.1.2) equal to or greater than 16	20
	AP contains broadcast address (3.1.2.4.1.2.3.1.3)	No reply
21	RR (3.1.2.6.1.2) less than 16	5
	RR (3.1.2.6.1.2) equal to or greater than 16	21
	AP contains broadcast address (3.1.2.4.1.2.3.1.3)	No reply
24	RC (3.1.2.7.1.1) equals 0 or 1	No reply
	RC (3.1.2.7.1.1) equals 2 or 3	24

Table 3-6. Table for register 10<sub>16</sub>

<i>Subfields of register 10<sub>16</sub></i>	<i>MB bits</i>	<i>Comm-B bits</i>
Continuation flag	9	41
ACAS capability	16 and 37-40	48 and 69-72
Mode S subnetwork version number	17-23	49-55
Transponder enhanced protocol indicator	24	56
Specific services capability	25	57
Uplink ELM capability	26-28	58-60
Downlink ELM capability	29-32	61-64
Aircraft identification capability	33	65
Squitter capability subfield (SCS)	34	66
Surveillance identifier code capability (SIC)	35	67
Common usage GICB capability report	36	68
Status of DTE sub-addresses 0 to 15	41-56	73-88

**Table 3-7. Surface format broadcast without an automatic means of on-the-ground determination**

<i>ADS-B Emitter Category set "A"</i>						
<i>Coding</i>	<i>Meaning</i>	<i>Ground Speed</i>		<i>Airspeed</i>		<i>Radio Altitude</i>
0	No ADS-B emitter category information	Always report airborne position message (3.1.2.8.6.3.1)				
1	Light (<15 500 lbs or 7 031 kg)	Always report airborne position message (3.1.2.8.6.3.1)				
2	Small (15 500 to 75 000 lbs or 7 031 to 34 019 kg)	< 100 knots	and	<100 knots	and	<50 feet
3	Large (75 000 lbs to 300 000 lbs or 34 019 to 136 078 kg)	<100 knots	and	<100 knots	and	<50 feet
4	High-vortex aircraft	<100 knots	and	<100 knots	and	<50 feet
5	Heavy (> 300 000 lbs or 136 078 kg)	<100 knots	and	<100 knots	and	<50 feet
6	High performance (>5g acceleration and >400 knots)	<100 knots	and	<100 knots	and	<50 feet
7	Rotorcraft	Always report airborne position message (3.1.2.8.6.3.1)				
<i>ADS-B Emitter Category Set "B"</i>						
<i>Coding</i>	<i>Meaning</i>	<i>Ground Speed</i>		<i>Airspeed</i>		<i>Radio Altitude</i>
0	No ADS-B emitter category information	Always report airborne position message (3.1.2.8.6.3.1)				
1	Glider/sailplane	Always report airborne position message (3.1.2.8.6.3.1)				
2	Lighter-than-air	Always report airborne position message (3.1.2.8.6.3.1)				
3	Parachutist/skydiver	Always report airborne position message (3.1.2.8.6.3.1)				
4	Ultra-light/hang-glider/paraglider	Always report airborne position message (3.1.2.8.6.3.1)				
5	Reserved	Reserved				
6	Unmanned aerial vehicle	Always report airborne position message (3.1.2.8.6.3.1)				
7	Space/trans-atmospheric vehicle	<100 knots	and	<100 knots	and	<50 feet
<i>ADS-B Emitter Category Set "C"</i>						
<i>Coding</i>	<i>Meaning</i>					
0	No ADS-B emitter category information	Always report airborne position message (3.1.2.8.6.3.1)				
1	Surface vehicle – emergency vehicle	Always report surface position message (3.1.2.8.6.3.2)				
2	Surface vehicle - service vehicle	Always report surface position message (3.1.2.8.6.3.2)				
3	Fixed ground or tethered obstruction	Always report airborne position message (3.1.2.8.6.3.1)				
4 – 7	Reserved	Reserved				
<i>ADS-B Emitter Category Set "D"</i>						
<i>Coding</i>	<i>Meaning</i>					
0	No ADS-B emitter category information	Always report airborne position message (3.1.2.8.6.3.1)				
1 – 7	Reserved	Reserved				

**Table 3-8. Character coding for transmission of aircraft identification by data link**  
(subset of IA-5 — see 3.1.2.9.1.2)

				$b_6$	0	0	1	1
				$b_5$	0	1	0	1
$b_4$	$b_3$	$b_2$	$b_1$					
0	0	0	0			P	SP	0
0	0	0	1		A	Q		1
0	0	1	0		B	R		2
0	0	1	1		C	S		3
0	1	0	0		D	T		4
0	1	0	1		E	U		5
0	1	1	0		F	V		6
0	1	1	1		G	W		7
1	0	0	0		H	X		8
1	0	0	1		I	Y		9
1	0	1	0		J	Z		
1	0	1	1		K			
1	1	0	0		L			
1	1	0	1		M			
1	1	1	0		N			
1	1	1	1		O			

**Table 3-9. Timer characteristics**

<i>Timer</i>				<i>Duration</i>	<i>Tolerance</i>	
<i>Name</i>	<i>Number</i>	<i>Reference</i>	<i>Symbol</i>	<i>s</i>	<i>s</i>	<i>Resettable</i>
Non-selective lock-out	1	3.1.2.6.9.2	$T_D$	18	±1	no
Temporary alert	1	3.1.2.6.10.1.1.2	$T_C$	18	±1	no
SPI	1	3.1.2.6.10.1.3	$T_I$	18	±1	no
Reservations B, C, D	3*	3.1.2.6.11.3.1	$T_R$	18	±1	yes
Multisite lockout	78	3.1.2.6.9.1	$T_L$	18	±1	no

\* As required

**Table 3-10. DAPs registers**

<i>Register</i>	<i>Name</i>	<i>Data content</i>	<i>Bits</i>
40 {HEX}	Selected vertical intention	MCP/FCU selected altitude	1-13
		FMS selected altitude	14-26
		Barometric pressure setting minus 800 mb	27-39
		MCP/FCU mode bits	48-51
		Target altitude source bits	54-56
50 {HEX}	Track and turn report	Roll angle	1-11
		True track angle	12-23
		Ground speed	24-34
		Track angle rate	35-45
		True airspeed	46-56
60 {HEX}	Heading and speed report	Magnetic heading	1-12
		Indicated airspeed	13-23
		Mach	24-34
		Barometric altitude rate	35-45
		Inertial vertical velocity	46-56

Table 3-11. Transmitted signal tolerances

<i>Reference</i>	<i>Function</i>	<i>Tolerance</i>
3.1.2.1.4.1	Pulse duration $P_1, P_2, P_3, P_4, P_5$ Pulse duration $P_6$	$\pm 0.09$ microsecond $\pm 0.20$ microsecond
3.1.1.4	Pulse duration $P_1 - P_3$ Pulse duration $P_1 - P_2$	$\pm 0.18$ microsecond $\pm 0.10$ microsecond
3.1.2.1.5.1.3	Pulse duration $P_3 - P_4$	$\pm 0.04$ microsecond
3.1.2.1.5.2.4	Pulse duration $P_1 - P_2$ Pulse duration $P_2$ — sync phase reversal Pulse duration $P_6$ — sync phase reversal Pulse duration $P_5$ — sync phase reversal	$\pm 0.04$ microsecond $\pm 0.04$ microsecond $\pm 0.04$ microsecond $\pm 0.05$ microsecond
3.1.1.5	Pulse amplitude $P_3$	$P_1 \pm 0.5$ dB
3.1.2.1.5.1.4	Pulse amplitude $P_4$	$P_3 \pm 0.5$ dB
3.1.2.1.5.2.5	Pulse amplitude $P_6$	Equal to or greater than $P_2 - 0.25$ dB
3.1.2.1.4.1	Pulse rise times	0.05 microsecond minimum, 0.1 microsecond maximum
3.1.2.1.4.1	Pulse decay times	0.05 microsecond minimum, 0.2 microsecond maximum

## FIGURES FOR CHAPTER 3

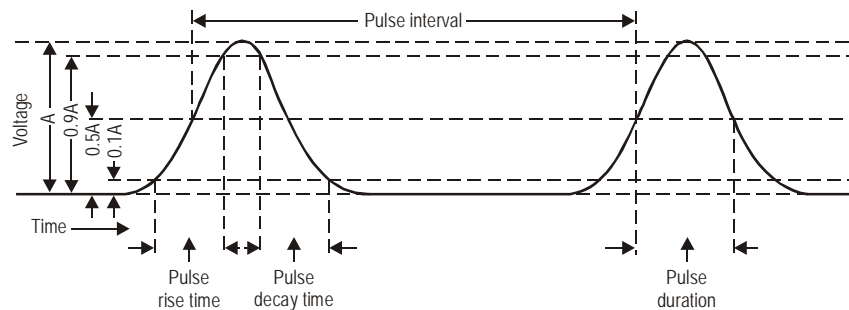

## Definitions

*Phase reversal.* A 180-degree change in the phase of the radio frequency carrier.

*Phase reversal duration.* The time between the 10-degree and 170-degree points of a phase reversal.

*Pulse amplitude A.* The peak voltage amplitude of the pulse envelope.

*Pulse decay time.* The time between 0.9A and 0.1A on the trailing edge of the pulse envelope.

*Pulse duration.* The time interval between 0.5A points on leading and trailing edges of the pulse envelope.

*Pulse interval.* The time interval between the 0.5A point on the leading edge of the first pulse and the 0.5A point on the leading edge of the second pulse.

*Pulse rise time.* The time between 0.1A and 0.9A on the leading edge of the pulse envelope.

*Time intervals.* The intervals are referenced to:

- the 0.5A point on the leading edge of a pulse;
- the 0.5A point on the trailing edge of a pulse; or
- the 90-degree point of a phase reversal.

*Transponder sensitivity and power reference point.* The antenna end of the transmission line of the transponder.

*Note.—* The 90-degree point of a phase reversal can be approximated by the minimum amplitude point on the envelope amplitude transient associated with the phase reversal and the phase reversal duration can be approximated by the time between the 0.8A points of the envelope amplitude transient.

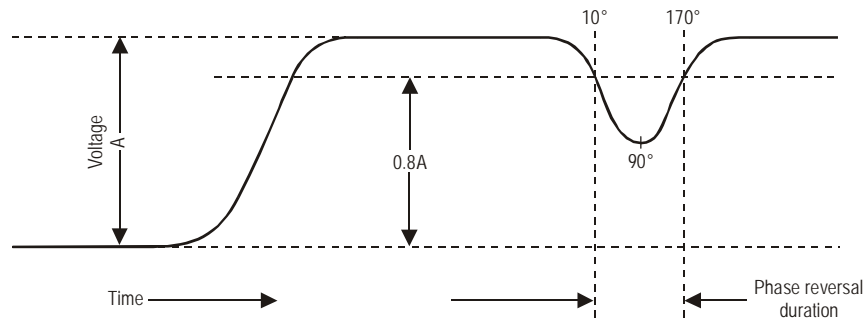

**Figure 3-1. Definitions of secondary surveillance radar waveform shapes, intervals and the reference point for sensitivity and power**

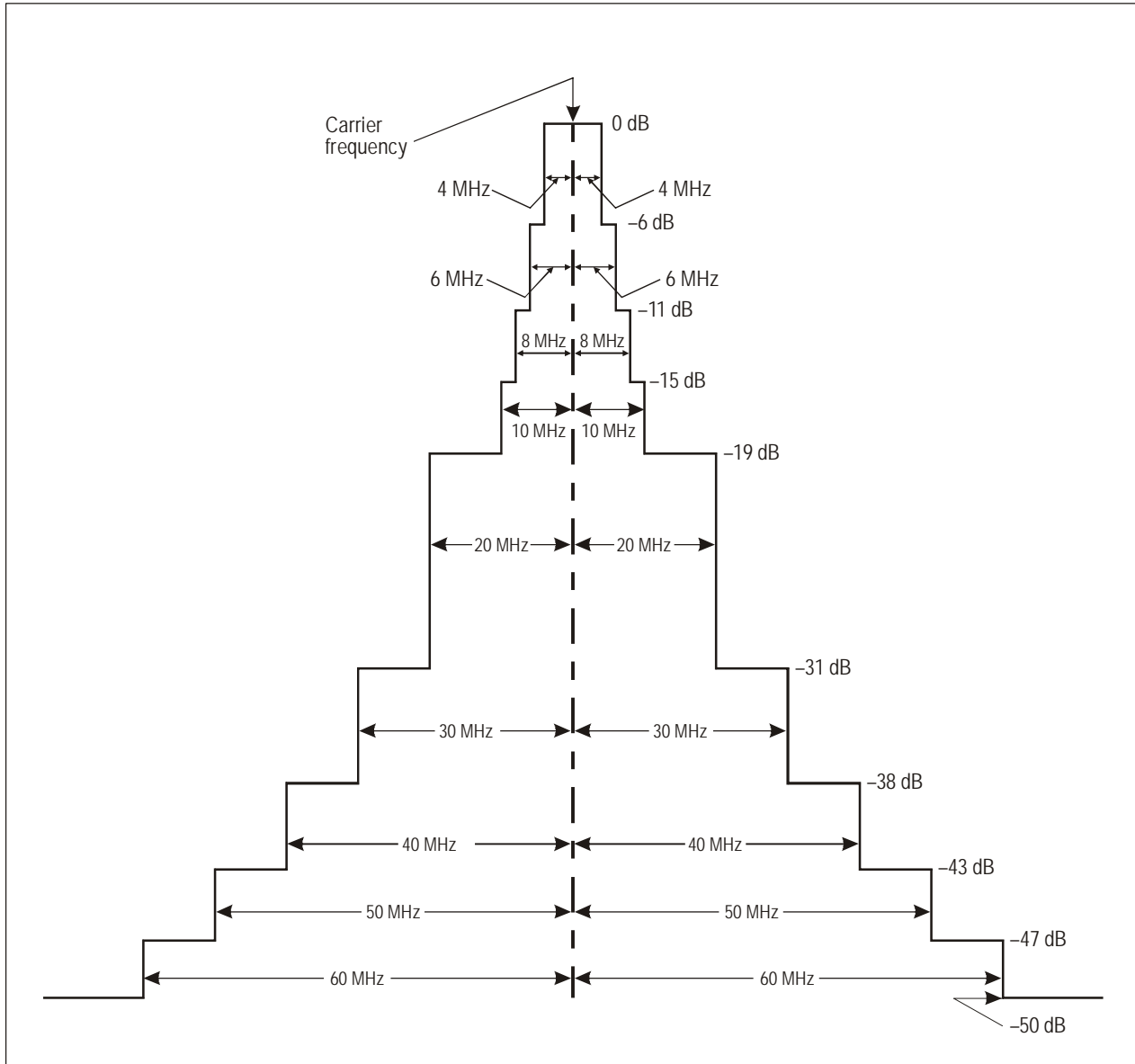

Figure 3-2. Required spectrum limits for interrogator transmitter

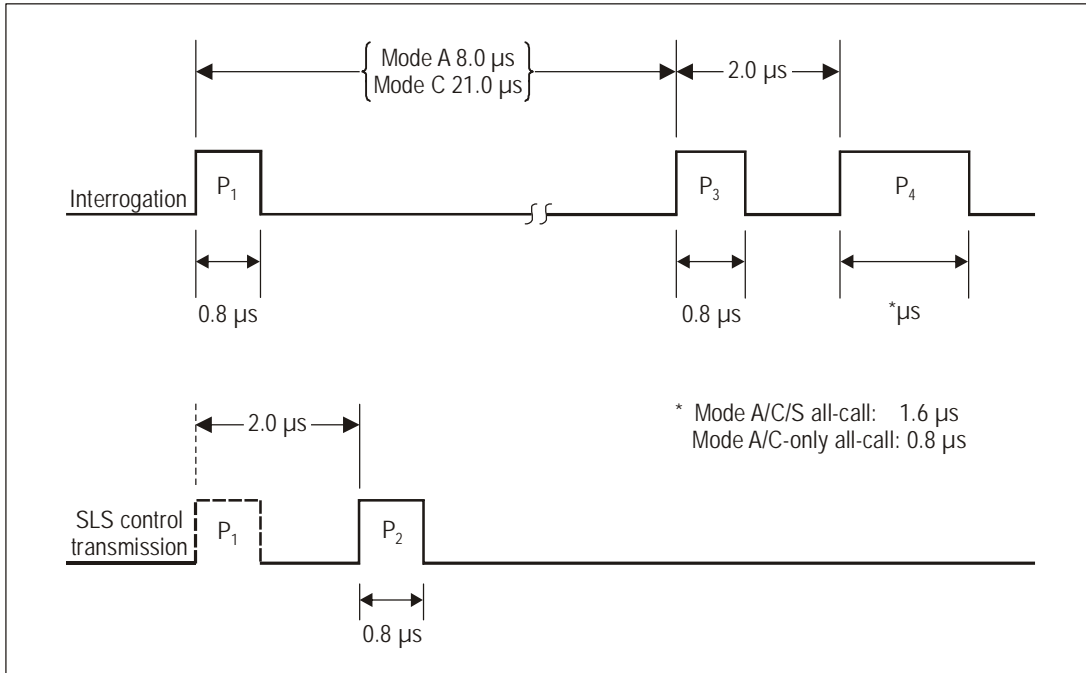

Figure 3-3. Intermode interrogation pulse sequence

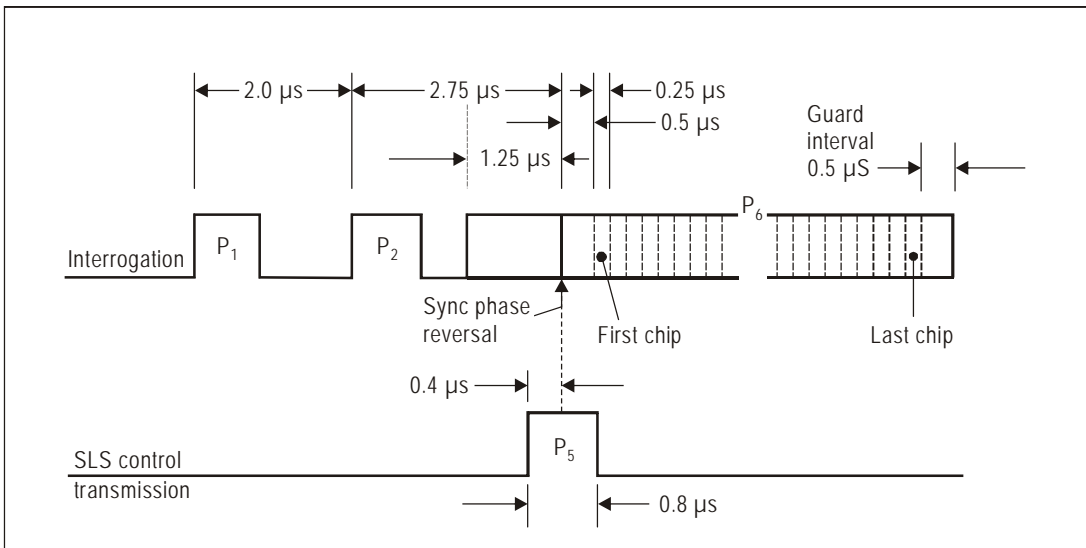
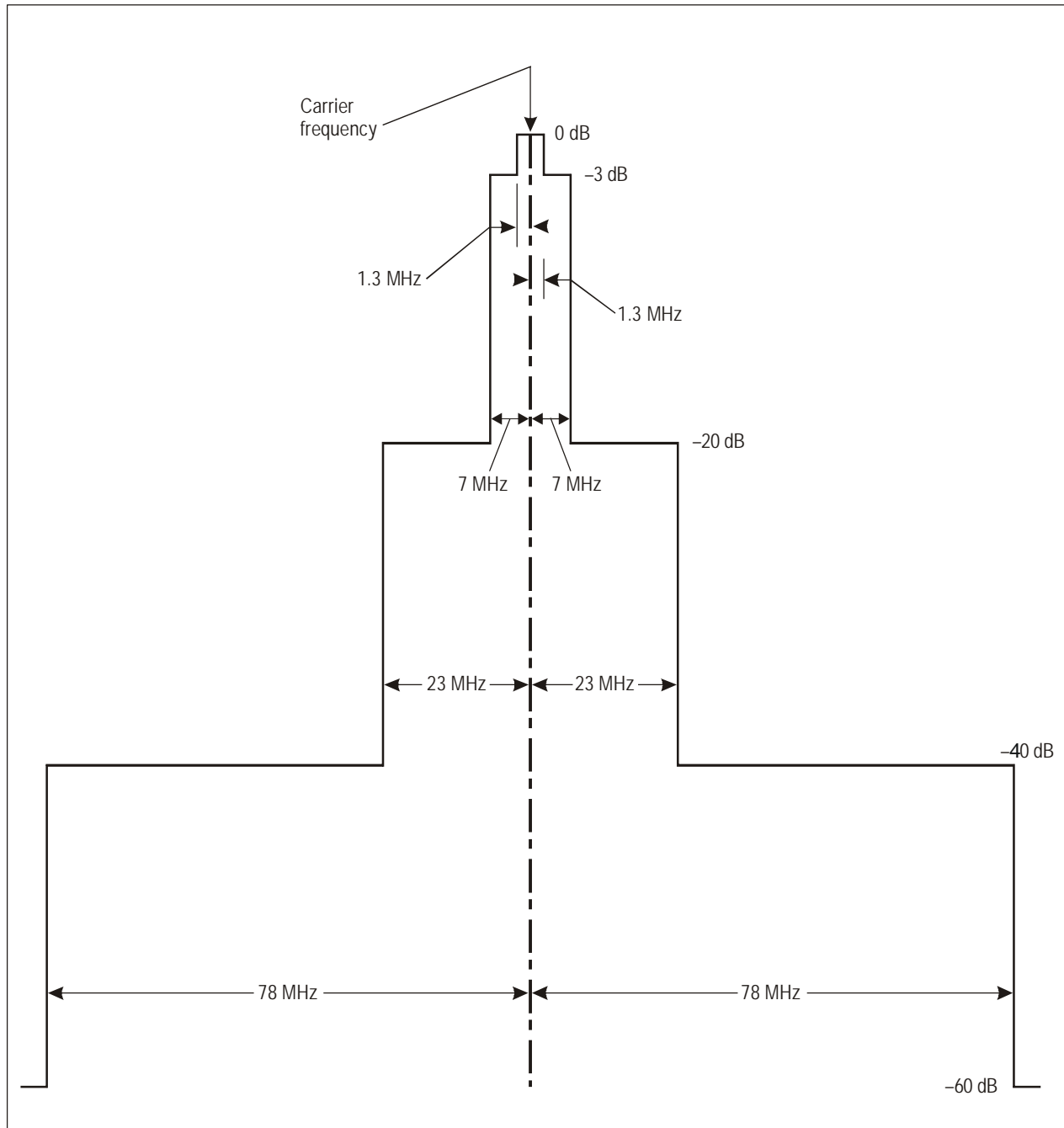

Figure 3-4. Mode S interrogation pulse sequence





**Figure 3-5. Required spectrum limits for transponder transmitter**

*Note.— This figure shows the spectrum centred on the carrier frequency and will therefore shift in its entirety plus or minus 1 MHz along with the carrier frequency.*

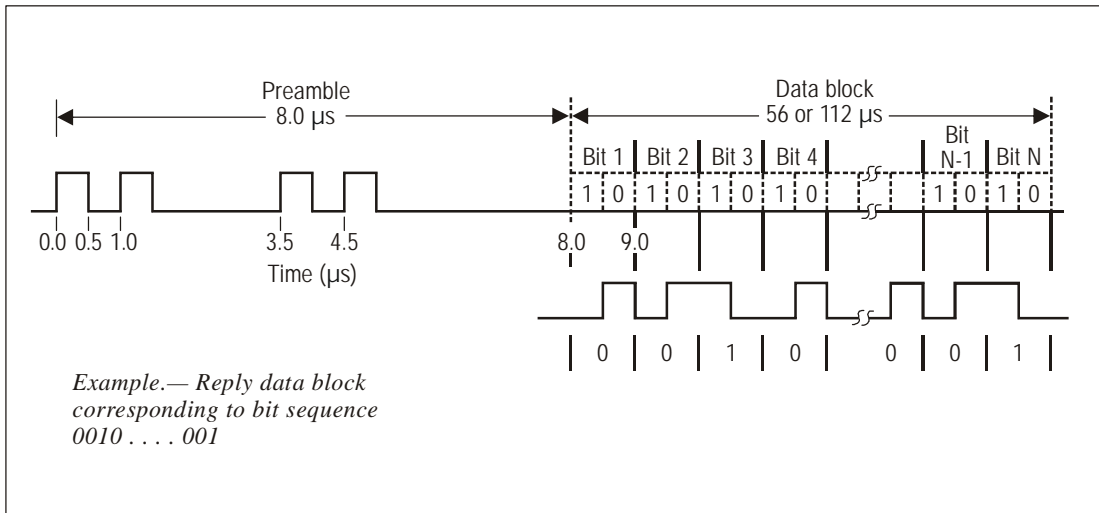

Figure 3-6. Mode S reply

Format No.	UF								
0	00000	3	RL:1	4	AQ:1	DS:8	10	AP:24	... Short air-air surveillance (ACAS)
1	00001	27 or 83						AP:24	... Reserved
2	00010	27 or 83						AP:24	... Reserved
3	00011	27 or 83						AP:24	... Reserved
4	00100	PC:3	RR:5	DI:3	SD:16	AP:24			... Surveillance, altitude request
5	00101	PC:3	RR:5	DI:3	SD:16	AP:24			... Surveillance, identify request
6	00110	27 or 83						AP:24	... Reserved
7	00111	27 or 83						AP:24	... Reserved
8	01000	27 or 83						AP:24	... Reserved
9	01001	27 or 83						AP:24	... Reserved
10	01010	27 or 83						AP:24	... Reserved
11	01011	PR:4	IC:4	CL:3	16		AP:24	... Mode S only all-call	
12	01100	27 or 83						AP:24	... Reserved
13	01101	27 or 83						AP:24	... Reserved
14	01110	27 or 83						AP:24	... Reserved
15	01111	27 or 83						AP:24	... Reserved
16	10000	3	RL:1	4	AQ:1	18	MU:56	AP:24	... Long air-air surveillance (ACAS)
17	10001	27 or 83						AP:24	... Reserved
18	10010	27 or 83						AP:24	... Reserved
19	10011	27 or 83						AP:24	... Reserved for military use
20	10100	PC:3	RR:5	DI:3	SD:16	MA:56	AP:24		... Comm-A, altitude request
21	10101	PC:3	RR:5	DI:3	SD:16	MA:56	AP:24		... Comm-A, identify request
22	10110	27 or 83						AP:24	... Reserved for military use
23	10111	27 or 83						AP:24	... Reserved
24	11	RC:2	NC:4	MC:80		AP:24		... Comm-C (ELM)	

## NOTES:

1. 

XX:M
------

 denotes a field designated "XX" which is assigned M bits.
2. 

N
---

 denotes unassigned coding space with N available bits. These shall be coded as ZEROs for transmission.
3. For uplink formats (UF) 0 to 23 the format number corresponds to the binary code in the first five bits of the interrogation. Format number 24 is defined as the format beginning with "11" in the first two bit positions while the following three bits vary with the interrogation content.
4. All formats are shown for completeness, although a number of them are unused. Those formats for which no application is presently defined remain undefined in length. Depending on future assignment they may be short (56 bits) or long (112 bits) formats. Specific formats associated with Mode S capability levels are described in later paragraphs.
5. The PC, RR, DI and SD fields do not apply to a Comm-A broadcast interrogation.

Figure 3-7. Summary of Mode S interrogation or uplink formats

Format No.	DF										
0	00000	VS:1	CC:1	1	SL:3	2	RI:4	2	AC:13	AP:24	... Short air-air surveillance (ACAS)
1	00001	27 or 83							P:24	... Reserved	
2	00010	27 or 83							P:24	... Reserved	
3	00011	27 or 83							P:24	... Reserved	
4	00100	FS:3	DR:5	UM:6	AC:13	AP:24	... Surveillance, altitude reply				
5	00101	FS:3	DR:5	UM:6	ID:13	AP:24	... Surveillance, identify reply				
6	00110	27 or 83							P:24	... Reserved	
7	00111	27 or 83							P:24	... Reserved	
8	01000	27 or 83							P:24	... Reserved	
9	01001	27 or 83							P:24	... Reserved	
10	01010	27 or 83							P:24	... Reserved	
11	01011	CA:3	AA:24	PI:24	... All-call reply						
12	01100	27 or 83							P:24	... Reserved	
13	01101	27 or 83							P:24	... Reserved	
14	01110	27 or 83							P:24	... Reserved	
15	01111	27 or 83							P:24	... Reserved	
16	10000	VS:1	2	SL:3	2	RI:4	2	AC:13	MV:56	AP:24	... Long air-air surveillance (ACAS)
17	10001	CA:3	AA:24	ME:56	PI:24	... Extended squitter					
18	10010	CF:3	AA:24	ME:56	PI:24	... Extended squitter/non transponder					
19	10011	AF:3	104								... Military extended squitter
20	10100	FS:3	DR:5	UM:6	AC:13	MB:56	AP:24	... Comm-B, altitude reply			
21	10101	FS:3	DR:5	UM:6	ID:13	MB:56	AP:24	... Comm-B, identify reply			
22	10110	27 or 83							P:24	... Reserved for military use	
23	10111	27 or 83							P:24	... Reserved	
24	11	1	KE:1	ND:4	MD:80	AP:24	... Comm-D (ELM)				

NOTES:

- |      |
|------|
| XX:M |
|------|

 denotes a field designated "XX" which is assigned M bits.
- |      |
|------|
| P:24 |
|------|

 denotes a 24-bit field reserved for parity information.
- |   |
|---|
| N |
|---|

 denotes unassigned coding space with N available bits. These shall be coded as ZEROS for transmission.
- For downlink formats (DF) 0 to 23 the format number corresponds to the binary code in the first five bits of the reply. Format number 24 is defined as the format beginning with "11" in the first two bit positions while the following three bits may vary with the reply content.
- All formats are shown for completeness, although a number of them are unused. Those formats for which no application is presently defined remain undefined in length. Depending on future assignment they may be short (56 bits) or long (112 bits) formats. Specific formats associated with Mode S capability levels are described in later paragraphs.

Figure 3-8. Summary of Mode S reply or downlink formats

## APPENDIX TO CHAPTER 3

SSR automatic pressure-altitude transmission code  
(pulse position assignment)

RANGE	PULSE POSITIONS (0 or 1 in a pulse position denotes absence or presence of a pulse, respectively)											
	Increments (Feet)	D <sub>2</sub>	D <sub>4</sub>	A <sub>1</sub>	A <sub>2</sub>	A <sub>4</sub>	B <sub>1</sub>	B <sub>2</sub>	B <sub>4</sub>	C <sub>1</sub>	C <sub>2</sub>	C <sub>4</sub>
-1 000 to -950	0	0	0	0	0	0	0	0	0	0	1	0
-950 to -850	0	0	0	0	0	0	0	0	0	1	1	0
-850 to -750	0	0	0	0	0	0	0	0	0	1	0	0
-750 to -650	0	0	0	0	0	0	0	0	1	1	0	0
-650 to -550	0	0	0	0	0	0	0	0	1	1	1	0
-550 to -450	0	0	0	0	0	0	0	0	1	0	1	0
-450 to -350	0	0	0	0	0	0	0	0	1	0	1	1
-350 to -250	0	0	0	0	0	0	0	0	1	0	0	1
-250 to -150	0	0	0	0	0	0	0	1	1	0	0	1
-150 to -50	0	0	0	0	0	0	0	1	1	0	1	1
-50 to 50	0	0	0	0	0	0	0	1	1	0	1	0
50 to 150	0	0	0	0	0	0	0	1	1	1	1	0
150 to 250	0	0	0	0	0	0	0	1	1	1	0	0
250 to 350	0	0	0	0	0	0	0	1	0	1	0	0
350 to 450	0	0	0	0	0	0	0	1	0	1	1	0
450 to 550	0	0	0	0	0	0	0	1	0	0	1	0
550 to 650	0	0	0	0	0	0	0	1	0	0	1	1
650 to 750	0	0	0	0	0	0	0	1	0	0	0	1
750 to 850	0	0	0	0	0	0	1	1	0	0	0	1
850 to 950	0	0	0	0	0	0	1	1	0	0	1	1
950 to 1 050	0	0	0	0	0	0	1	1	0	0	1	0
1 050 to 1 150	0	0	0	0	0	0	1	1	0	1	1	0
1 150 to 1 250	0	0	0	0	0	0	1	1	0	1	0	0
1 250 to 1 350	0	0	0	0	0	0	1	1	1	1	0	0
1 350 to 1 450	0	0	0	0	0	0	1	1	1	1	1	0
1 450 to 1 550	0	0	0	0	0	0	1	1	1	0	1	0
1 550 to 1 650	0	0	0	0	0	0	1	1	1	0	1	1
1 650 to 1 750	0	0	0	0	0	0	1	1	1	0	0	1
1 750 to 1 850	0	0	0	0	0	0	1	0	1	0	0	1
1 850 to 1 950	0	0	0	0	0	0	1	0	1	0	1	1
1 950 to 2 050	0	0	0	0	0	0	1	0	1	0	1	0
2 050 to 2 150	0	0	0	0	0	0	1	0	1	1	1	0
2 150 to 2 250	0	0	0	0	0	0	1	0	1	1	0	0
2 250 to 2 350	0	0	0	0	0	0	1	0	0	1	0	0
2 350 to 2 450	0	0	0	0	0	0	1	0	0	1	1	0
2 450 to 2 550	0	0	0	0	0	0	1	0	0	0	1	0
2 550 to 2 650	0	0	0	0	0	0	1	0	0	0	1	1
2 650 to 2 750	0	0	0	0	0	0	1	0	0	0	0	1

RANGE	PULSE POSITIONS (0 or 1 in a pulse position denotes absence or presence of a pulse, respectively)											
	Increments (Feet)	D <sub>2</sub>	D <sub>4</sub>	A <sub>1</sub>	A <sub>2</sub>	A <sub>4</sub>	B <sub>1</sub>	B <sub>2</sub>	B <sub>4</sub>	C <sub>1</sub>	C <sub>2</sub>	C <sub>4</sub>
2 750 to 2 850	0	0	0	0	1	1	0	0	0	0	0	1
2 850 to 2 950	0	0	0	0	1	1	0	0	0	0	1	1
2 950 to 3 050	0	0	0	0	1	1	0	0	0	0	1	0
3 050 to 3 150	0	0	0	0	1	1	0	0	0	1	1	0
3 150 to 3 250	0	0	0	0	1	1	0	0	0	1	0	0
3 250 to 3 350	0	0	0	0	1	1	0	1	1	0	0	0
3 350 to 3 450	0	0	0	0	1	1	0	1	1	1	1	0
3 450 to 3 550	0	0	0	0	1	1	0	1	0	1	0	0
3 550 to 3 650	0	0	0	0	1	1	0	1	0	1	1	1
3 650 to 3 750	0	0	0	0	1	1	0	1	0	0	0	1
3 750 to 3 850	0	0	0	0	1	1	1	1	0	0	0	1
3 850 to 3 950	0	0	0	0	1	1	1	1	0	1	1	1
3 950 to 4 050	0	0	0	0	1	1	1	1	0	1	0	0
4 050 to 4 150	0	0	0	0	1	1	1	1	1	1	1	0
4 150 to 4 250	0	0	0	0	1	1	1	1	1	1	0	0
4 250 to 4 350	0	0	0	0	1	1	1	0	1	0	0	0
4 350 to 4 450	0	0	0	0	1	1	1	0	1	1	0	0
4 450 to 4 550	0	0	0	0	1	1	1	0	0	1	0	0
4 550 to 4 650	0	0	0	0	1	1	1	0	0	1	1	1
4 650 to 4 750	0	0	0	0	1	1	1	0	0	0	0	1
4 750 to 4 850	0	0	0	0	1	0	1	0	0	0	0	1
4 850 to 4 950	0	0	0	0	1	0	1	0	0	1	1	1
4 950 to 5 050	0	0	0	0	1	0	1	0	0	1	0	0
5 050 to 5 150	0	0	0	0	1	0	1	0	1	1	0	0
5 150 to 5 250	0	0	0	0	1	0	1	0	1	0	0	0
5 250 to 5 350	0	0	0	0	1	0	1	1	1	0	0	0
5 350 to 5 450	0	0	0	0	1	0	1	1	1	1	1	0
5 450 to 5 550	0	0	0	0	1	0	1	1	0	1	0	0
5 550 to 5 650	0	0	0	0	1	0	1	1	0	1	1	1
5 650 to 5 750	0	0	0	0	1	0	1	1	0	0	0	1
5 750 to 5 850	0	0	0	0	1	0	0	1	0	0	0	1
5 850 to 5 950	0	0	0	0	1	0	0	1	0	1	1	1
5 950 to 6 050	0	0	0	0	1	0	0	1	0	1	0	0
6 050 to 6 150	0	0	0	0	1	0	0	1	1	1	0	0
6 150 to 6 250	0	0	0	0	1	0	0	1	1	0	0	0
6 250 to 6 350	0	0	0	0	1	0	0	0	1	0	0	0
6 350 to 6 450	0	0	0	0	1	0	0	0	1	1	0	0
6 450 to 6 550	0	0	0	0	1	0	0	0	0	1	0	0
6 550 to 6 650	0	0	0	0	1	0	0	0	0	1	1	1
6 650 to 6 750	0	0	0	0	1	0	0	0	0	0	0	1
6 750 to 6 850	0	0	0	1	1	0	0	0	0	0	0	1
6 850 to 6 950	0	0	0	1	1	0	0	0	0	1	1	1
6 950 to 7 050	0	0	0	1	1	0	0	0	0	1	0	0
7 050 to 7 150	0	0	0	1	1	0	0	0	1	1	0	0
7 150 to 7 250	0	0	0	1	1	0	0	0	1	0	0	0

RANGE	PULSE POSITIONS (0 or 1 in a pulse position denotes absence or presence of a pulse, respectively)										
	Increments (Feet)	D <sub>2</sub>	D <sub>4</sub>	A <sub>1</sub>	A <sub>2</sub>	A <sub>4</sub>	B <sub>1</sub>	B <sub>2</sub>	B <sub>4</sub>	C <sub>1</sub>	C <sub>2</sub>
7 250 to 7 350	0	0	0	1	1	0	0	1	1	0	0
7 350 to 7 450	0	0	0	1	1	0	0	1	1	1	0
7 450 to 7 550	0	0	0	1	1	0	0	1	0	1	0
7 550 to 7 650	0	0	0	1	1	0	0	1	0	1	1
7 650 to 7 750	0	0	0	1	1	0	0	1	0	0	1
7 750 to 7 850	0	0	0	1	1	0	1	1	0	0	1
7 850 to 7 950	0	0	0	1	1	0	1	1	0	1	1
7 950 to 8 050	0	0	0	1	1	0	1	1	0	1	0
8 050 to 8 150	0	0	0	1	1	0	1	1	1	1	0
8 150 to 8 250	0	0	0	1	1	0	1	1	1	0	0
8 250 to 8 350	0	0	0	1	1	0	1	0	1	0	0
8 350 to 8 450	0	0	0	1	1	0	1	0	1	1	0
8 450 to 8 550	0	0	0	1	1	0	1	0	0	1	0
8 550 to 8 650	0	0	0	1	1	0	1	0	0	1	1
8 650 to 8 750	0	0	0	1	1	0	1	0	0	0	1
8 750 to 8 850	0	0	0	1	1	1	1	0	0	0	1
8 850 to 8 950	0	0	0	1	1	1	1	0	0	1	1
8 950 to 9 050	0	0	0	1	1	1	1	0	0	1	0
9 050 to 9 150	0	0	0	1	1	1	1	0	1	1	0
9 150 to 9 250	0	0	0	1	1	1	1	0	1	0	0
9 250 to 9 350	0	0	0	1	1	1	1	1	1	0	0
9 350 to 9 450	0	0	0	1	1	1	1	1	1	1	0
9 450 to 9 550	0	0	0	1	1	1	1	1	0	1	0
9 550 to 9 650	0	0	0	1	1	1	1	1	0	1	1
9 650 to 9 750	0	0	0	1	1	1	1	1	0	0	1
9 750 to 9 850	0	0	0	1	1	1	0	1	0	0	1
9 850 to 9 950	0	0	0	1	1	1	0	1	0	1	1
9 950 to 10 050	0	0	0	1	1	1	0	1	0	1	0
10 050 to 10 150	0	0	0	1	1	1	0	1	1	1	0
10 150 to 10 250	0	0	0	1	1	1	0	1	1	0	0
10 250 to 10 350	0	0	0	1	1	1	0	0	1	0	0
10 350 to 10 450	0	0	0	1	1	1	0	0	1	1	0
10 450 to 10 550	0	0	0	1	1	1	0	0	0	1	0
10 550 to 10 650	0	0	0	1	1	1	0	0	0	1	1
10 650 to 10 750	0	0	0	1	1	1	0	0	0	0	1
10 750 to 10 850	0	0	0	1	0	1	0	0	0	0	1
10 850 to 10 950	0	0	0	1	0	1	0	0	0	1	1
10 950 to 11 050	0	0	0	1	0	1	0	0	0	1	0
11 050 to 11 150	0	0	0	1	0	1	0	0	1	1	0
11 150 to 11 250	0	0	0	1	0	1	0	0	1	0	0
11 250 to 11 350	0	0	0	1	0	1	0	1	1	0	0
11 350 to 11 450	0	0	0	1	0	1	0	1	1	1	0
11 450 to 11 550	0	0	0	1	0	1	0	1	0	1	0
11 550 to 11 650	0	0	0	1	0	1	0	1	0	1	1
11 650 to 11 750	0	0	0	1	0	1	0	1	0	0	1

RANGE	PULSE POSITIONS (0 or 1 in a pulse position denotes absence or presence of a pulse, respectively)													
	Increments (Feet)			D <sub>2</sub>	D <sub>4</sub>	A <sub>1</sub>	A <sub>2</sub>	A <sub>4</sub>	B <sub>1</sub>	B <sub>2</sub>	B <sub>4</sub>	C <sub>1</sub>	C <sub>2</sub>	C <sub>4</sub>
11 750 to 11 850	0	0	0	1	0	1	1	1	0	0	1	0	0	1
11 850 to 11 950	0	0	0	1	0	1	1	1	0	0	1	0	1	1
11 950 to 12 050	0	0	0	1	0	1	1	1	0	0	1	0	1	0
12 050 to 12 150	0	0	0	1	0	1	1	1	0	0	1	1	1	0
12 150 to 12 250	0	0	0	1	0	1	1	1	0	0	1	1	0	0
12 250 to 12 350	0	0	0	1	0	1	1	0	0	0	1	1	0	0
12 350 to 12 450	0	0	0	1	0	1	1	0	0	0	1	1	1	0
12 450 to 12 550	0	0	0	1	0	1	1	0	0	0	1	0	1	0
12 550 to 12 650	0	0	0	1	0	1	1	0	0	0	1	0	1	1
12 650 to 12 750	0	0	0	1	0	1	1	0	0	0	1	0	0	1
12 750 to 12 850	0	0	0	1	0	0	1	0	0	0	1	0	0	1
12 850 to 12 950	0	0	0	1	0	0	1	0	0	0	1	0	1	1
12 950 to 13 050	0	0	0	1	0	0	1	0	0	0	1	0	1	0
13 050 to 13 150	0	0	0	1	0	0	1	0	0	0	1	1	1	0
13 150 to 13 250	0	0	0	1	0	0	1	0	0	0	1	1	0	0
13 250 to 13 350	0	0	0	1	0	0	1	1	0	0	1	1	0	0
13 350 to 13 450	0	0	0	1	0	0	1	1	0	0	1	1	1	0
13 450 to 13 550	0	0	0	1	0	0	1	1	0	0	1	0	1	0
13 550 to 13 650	0	0	0	1	0	0	1	1	0	0	1	0	1	1
13 650 to 13 750	0	0	0	1	0	0	1	1	0	0	1	0	0	1
13 750 to 13 850	0	0	0	1	0	0	0	1	0	0	0	0	0	1
13 850 to 13 950	0	0	0	1	0	0	0	1	0	0	0	0	1	1
13 950 to 14 050	0	0	0	1	0	0	0	1	0	0	0	0	1	0
14 050 to 14 150	0	0	0	1	0	0	0	1	0	0	0	1	1	0
14 150 to 14 250	0	0	0	1	0	0	0	1	0	0	0	1	0	0
14 250 to 14 350	0	0	0	1	0	0	0	0	0	0	0	1	0	0
14 350 to 14 450	0	0	0	1	0	0	0	0	0	0	0	1	1	0
14 450 to 14 550	0	0	0	1	0	0	0	0	0	0	0	0	1	0
14 550 to 14 650	0	0	0	1	0	0	0	0	0	0	0	0	1	1
14 650 to 14 750	0	0	0	1	0	0	0	0	0	0	0	0	0	1
14 750 to 14 850	0	0	1	1	0	0	0	0	0	0	0	0	0	1
14 850 to 14 950	0	0	1	1	0	0	0	0	0	0	0	0	1	1
14 950 to 15 050	0	0	1	1	0	0	0	0	0	0	0	0	1	0
15 050 to 15 150	0	0	1	1	0	0	0	0	0	0	0	1	1	0
15 150 to 15 250	0	0	1	1	0	0	0	0	0	0	0	1	0	0
15 250 to 15 350	0	0	1	1	0	0	0	1	0	0	0	1	0	0
15 350 to 15 450	0	0	1	1	0	0	0	1	0	0	0	1	1	0
15 450 to 15 550	0	0	1	1	0	0	0	1	0	0	0	0	1	0
15 550 to 15 650	0	0	1	1	0	0	0	1	0	0	0	0	1	1
15 650 to 15 750	0	0	1	1	0	0	0	1	0	0	0	0	0	1
15 750 to 15 850	0	0	1	1	0	0	1	1	0	0	0	0	0	1
15 850 to 15 950	0	0	1	1	0	0	1	1	0	0	0	0	1	1
15 950 to 16 050	0	0	1	1	0	0	1	1	0	0	0	0	1	0
16 050 to 16 150	0	0	1	1	0	0	1	1	0	0	0	1	1	0
16 150 to 16 250	0	0	1	1	0	0	1	1	0	0	0	1	0	0



RANGE	PULSE POSITIONS (0 or 1 in a pulse position denotes absence or presence of a pulse, respectively)												
	Increments (Feet)			D <sub>2</sub>	D <sub>4</sub>	A <sub>1</sub>	A <sub>2</sub>	A <sub>4</sub>	B <sub>1</sub>	B <sub>2</sub>	B <sub>4</sub>	C <sub>1</sub>	C <sub>2</sub>
16 250 to 16 350	0	0	1	1	0	0	1	0	1	0	1	0	0
16 350 to 16 450	0	0	1	1	0	0	1	0	1	0	1	1	0
16 450 to 16 550	0	0	1	1	0	0	1	0	1	0	0	1	0
16 550 to 16 650	0	0	1	1	0	0	1	0	1	0	0	1	1
16 650 to 16 750	0	0	1	1	0	0	1	0	1	0	0	0	1
16 750 to 16 850	0	0	1	1	0	1	1	1	0	0	0	0	1
16 850 to 16 950	0	0	1	1	0	1	1	1	0	0	0	1	1
16 950 to 17 050	0	0	1	1	0	1	1	1	0	0	0	1	0
17 050 to 17 150	0	0	1	1	0	1	1	1	0	1	1	1	0
17 150 to 17 250	0	0	1	1	0	1	1	1	0	1	1	0	0
17 250 to 17 350	0	0	1	1	0	1	1	1	1	1	1	0	0
17 350 to 17 450	0	0	1	1	0	1	1	1	1	1	1	1	0
17 450 to 17 550	0	0	1	1	0	1	1	1	1	1	0	1	0
17 550 to 17 650	0	0	1	1	0	1	1	1	1	1	0	1	1
17 650 to 17 750	0	0	1	1	0	1	1	1	1	1	0	0	1
17 750 to 17 850	0	0	1	1	0	1	0	1	0	1	0	0	1
17 850 to 17 950	0	0	1	1	0	1	0	1	0	1	0	1	1
17 950 to 18 050	0	0	1	1	0	1	0	1	0	1	0	1	0
18 050 to 18 150	0	0	1	1	0	1	0	1	0	1	1	1	0
18 150 to 18 250	0	0	1	1	0	1	0	1	0	1	1	0	0
18 250 to 18 350	0	0	1	1	0	1	0	0	0	1	0	0	0
18 350 to 18 450	0	0	1	1	0	1	0	0	0	1	1	1	0
18 450 to 18 550	0	0	1	1	0	1	0	0	0	0	1	0	0
18 550 to 18 650	0	0	1	1	0	1	0	0	0	0	1	1	1
18 650 to 18 750	0	0	1	1	0	1	0	0	0	0	0	0	1
18 750 to 18 850	0	0	1	1	1	1	0	0	0	0	0	0	1
18 850 to 18 950	0	0	1	1	1	1	0	0	0	0	0	1	1
18 950 to 19 050	0	0	1	1	1	1	0	0	0	0	0	1	0
19 050 to 19 150	0	0	1	1	1	1	0	0	0	1	1	1	0
19 150 to 19 250	0	0	1	1	1	1	0	0	0	1	0	0	0
19 250 to 19 350	0	0	1	1	1	1	0	1	1	1	0	0	0
19 350 to 19 450	0	0	1	1	1	1	0	1	1	1	1	1	0
19 450 to 19 550	0	0	1	1	1	1	0	1	0	1	0	1	0
19 550 to 19 650	0	0	1	1	1	1	0	1	0	1	0	1	1
19 650 to 19 750	0	0	1	1	1	1	0	1	0	1	0	0	1
19 750 to 19 850	0	0	1	1	1	1	1	1	1	1	0	0	1
19 850 to 19 950	0	0	1	1	1	1	1	1	1	1	0	1	1
19 950 to 20 050	0	0	1	1	1	1	1	1	1	1	0	1	0
20 050 to 20 150	0	0	1	1	1	1	1	1	1	1	1	1	0
20 150 to 20 250	0	0	1	1	1	1	1	1	1	1	1	0	0
20 250 to 20 350	0	0	1	1	1	1	1	0	1	1	0	0	0
20 350 to 20 450	0	0	1	1	1	1	1	0	1	1	1	1	0
20 450 to 20 550	0	0	1	1	1	1	1	0	1	0	0	1	0
20 550 to 20 650	0	0	1	1	1	1	1	0	1	0	0	1	1
20 650 to 20 750	0	0	1	1	1	1	1	0	1	0	0	0	1

RANGE	PULSE POSITIONS (0 or 1 in a pulse position denotes absence or presence of a pulse, respectively)												
	Increments (Feet)		D <sub>2</sub>	D <sub>4</sub>	A <sub>1</sub>	A <sub>2</sub>	A <sub>4</sub>	B <sub>1</sub>	B <sub>2</sub>	B <sub>4</sub>	C <sub>1</sub>	C <sub>2</sub>	C <sub>4</sub>
20 750 to 20 850			0	0	1	1	1	0	1	0	0	0	1
20 850 to 20 950			0	0	1	1	1	0	1	0	0	1	1
20 950 to 21 050			0	0	1	1	1	0	1	0	0	1	0
21 050 to 21 150			0	0	1	1	1	0	1	0	1	1	0
21 150 to 21 250			0	0	1	1	1	0	1	0	1	0	0
21 250 to 21 350			0	0	1	1	1	0	1	1	1	0	0
21 350 to 21 450			0	0	1	1	1	0	1	1	1	1	0
21 450 to 21 550			0	0	1	1	1	0	1	1	0	1	0
21 550 to 21 650			0	0	1	1	1	0	1	1	0	1	1
21 650 to 21 750			0	0	1	1	1	0	1	1	0	0	1
21 750 to 21 850			0	0	1	1	1	0	0	1	0	0	1
21 850 to 21 950			0	0	1	1	1	0	0	1	0	1	1
21 950 to 22 050			0	0	1	1	1	0	0	1	0	1	0
22 050 to 22 150			0	0	1	1	1	0	0	1	1	1	0
22 150 to 22 250			0	0	1	1	1	0	0	1	1	0	0
22 250 to 22 350			0	0	1	1	1	0	0	0	1	0	0
22 350 to 22 450			0	0	1	1	1	0	0	0	1	1	0
22 450 to 22 550			0	0	1	1	1	0	0	0	0	1	0
22 550 to 22 650			0	0	1	1	1	0	0	0	0	1	1
22 650 to 22 750			0	0	1	1	1	0	0	0	0	0	1
22 750 to 22 850			0	0	1	0	1	0	0	0	0	0	1
22 850 to 22 950			0	0	1	0	1	0	0	0	0	1	1
22 950 to 23 050			0	0	1	0	1	0	0	0	0	1	0
23 050 to 23 150			0	0	1	0	1	0	0	0	1	1	0
23 150 to 23 250			0	0	1	0	1	0	0	0	1	0	0
23 250 to 23 350			0	0	1	0	1	0	0	1	1	0	0
23 350 to 23 450			0	0	1	0	1	0	0	1	1	1	0
23 450 to 23 550			0	0	1	0	1	0	0	1	0	1	0
23 550 to 23 650			0	0	1	0	1	0	0	1	0	1	1
23 650 to 23 750			0	0	1	0	1	0	0	1	0	0	1
23 750 to 23 850			0	0	1	0	1	0	1	1	0	0	1
23 850 to 23 950			0	0	1	0	1	0	1	1	0	1	1
23 950 to 24 050			0	0	1	0	1	0	1	1	0	1	0
24 050 to 24 150			0	0	1	0	1	0	1	1	1	1	0
24 150 to 24 250			0	0	1	0	1	0	1	1	1	0	0
24 250 to 24 350			0	0	1	0	1	0	1	0	1	0	0
24 350 to 24 450			0	0	1	0	1	0	1	0	1	1	0
24 450 to 24 550			0	0	1	0	1	0	1	0	0	1	0
24 550 to 24 650			0	0	1	0	1	0	1	0	0	1	1
24 650 to 24 750			0	0	1	0	1	0	1	0	0	0	1
24 750 to 24 850			0	0	1	0	1	1	1	0	0	0	1
24 850 to 24 950			0	0	1	0	1	1	1	0	0	1	1
24 950 to 25 050			0	0	1	0	1	1	1	0	0	1	0
25 050 to 25 150			0	0	1	0	1	1	1	0	1	1	0
25 150 to 25 250			0	0	1	0	1	1	1	0	1	0	0

RANGE	PULSE POSITIONS (0 or 1 in a pulse position denotes absence or presence of a pulse, respectively)												
	Increments (Feet)			D <sub>2</sub>	D <sub>4</sub>	A <sub>1</sub>	A <sub>2</sub>	A <sub>4</sub>	B <sub>1</sub>	B <sub>2</sub>	B <sub>4</sub>	C <sub>1</sub>	C <sub>2</sub>
25 250 to 25 350	0	0	1	0	1	1	1	1	1	1	1	0	0
25 350 to 25 450	0	0	1	0	1	1	1	1	1	1	1	1	0
25 450 to 25 550	0	0	1	0	1	1	1	1	1	1	0	1	0
25 550 to 25 650	0	0	1	0	1	1	1	1	1	1	0	1	1
25 650 to 25 750	0	0	1	0	1	1	1	1	1	1	0	0	1
25 750 to 25 850	0	0	1	0	1	1	0	1	0	1	0	0	1
25 850 to 25 950	0	0	1	0	1	1	0	1	0	1	0	1	1
25 950 to 26 050	0	0	1	0	1	1	0	1	0	1	0	1	0
26 050 to 26 150	0	0	1	0	1	1	0	1	0	1	1	1	0
26 150 to 26 250	0	0	1	0	1	1	0	1	0	1	1	0	0
26 250 to 26 350	0	0	1	0	1	1	0	0	0	0	1	0	0
26 350 to 26 450	0	0	1	0	1	1	0	0	0	0	1	1	0
26 450 to 26 550	0	0	1	0	1	1	0	0	0	0	0	1	0
26 550 to 26 650	0	0	1	0	1	1	0	0	0	0	0	1	1
26 650 to 26 750	0	0	1	0	1	1	0	0	0	0	0	0	1
26 750 to 26 850	0	0	1	0	0	1	0	0	0	0	0	0	1
26 850 to 26 950	0	0	1	0	0	1	0	0	0	0	0	1	1
26 950 to 27 050	0	0	1	0	0	1	0	0	0	0	0	1	0
27 050 to 27 150	0	0	1	0	0	1	0	0	0	0	1	1	0
27 150 to 27 250	0	0	1	0	0	1	0	0	0	0	1	0	0
27 250 to 27 350	0	0	1	0	0	1	0	1	0	1	1	0	0
27 350 to 27 450	0	0	1	0	0	1	0	1	0	1	1	1	0
27 450 to 27 550	0	0	1	0	0	1	0	1	0	1	0	1	0
27 550 to 27 650	0	0	1	0	0	1	0	1	0	1	0	1	1
27 650 to 27 750	0	0	1	0	0	1	0	1	0	1	0	0	1
27 750 to 27 850	0	0	1	0	0	1	1	1	1	1	0	0	1
27 850 to 27 950	0	0	1	0	0	1	1	1	1	1	0	1	1
27 950 to 28 050	0	0	1	0	0	1	1	1	1	1	0	1	0
28 050 to 28 150	0	0	1	0	0	1	1	1	1	1	1	1	0
28 150 to 28 250	0	0	1	0	0	1	1	1	1	1	1	0	0
28 250 to 28 350	0	0	1	0	0	1	1	0	0	0	1	0	0
28 350 to 28 450	0	0	1	0	0	1	1	0	0	0	1	1	0
28 450 to 28 550	0	0	1	0	0	1	1	0	0	0	0	1	0
28 550 to 28 650	0	0	1	0	0	1	1	0	0	0	0	1	1
28 650 to 28 750	0	0	1	0	0	1	1	0	0	0	0	0	1
28 750 to 28 850	0	0	1	0	0	0	1	0	0	0	0	0	1
28 850 to 28 950	0	0	1	0	0	0	0	1	0	0	0	1	1
28 950 to 29 050	0	0	1	0	0	0	0	1	0	0	0	1	0
29 050 to 29 150	0	0	1	0	0	0	0	1	0	0	1	1	0
29 150 to 29 250	0	0	1	0	0	0	0	1	0	0	1	0	0
29 250 to 29 350	0	0	1	0	0	0	0	1	1	1	1	0	0
29 350 to 29 450	0	0	1	0	0	0	0	1	1	1	1	1	0
29 450 to 29 550	0	0	1	0	0	0	0	1	1	1	0	1	0
29 550 to 29 650	0	0	1	0	0	0	0	1	1	1	0	1	1
29 650 to 29 750	0	0	1	0	0	0	0	1	1	1	0	0	1

RANGE	PULSE POSITIONS (0 or 1 in a pulse position denotes absence or presence of a pulse, respectively)												
	Increments (Feet)		D <sub>2</sub>	D <sub>4</sub>	A <sub>1</sub>	A <sub>2</sub>	A <sub>4</sub>	B <sub>1</sub>	B <sub>2</sub>	B <sub>4</sub>	C <sub>1</sub>	C <sub>2</sub>	C <sub>4</sub>
29 750 to 29 850			0	0	1	0	0	0	0	1	0	0	1
29 850 to 29 950			0	0	1	0	0	0	0	1	0	1	1
29 950 to 30 050			0	0	1	0	0	0	0	1	0	1	0
30 050 to 30 150			0	0	1	0	0	0	0	1	1	1	0
30 150 to 30 250			0	0	1	0	0	0	0	1	1	0	0
30 250 to 30 350			0	0	1	0	0	0	0	0	1	0	0
30 350 to 30 450			0	0	1	0	0	0	0	0	1	1	0
30 450 to 30 550			0	0	1	0	0	0	0	0	0	1	0
30 550 to 30 650			0	0	1	0	0	0	0	0	0	1	1
30 650 to 30 750			0	0	1	0	0	0	0	0	0	0	1
30 750 to 30 850			0	1	1	0	0	0	0	0	0	0	1
30 850 to 30 950			0	1	1	0	0	0	0	0	0	1	1
30 950 to 31 050			0	1	1	0	0	0	0	0	0	1	0
31 050 to 31 150			0	1	1	0	0	0	0	0	1	1	0
31 150 to 31 250			0	1	1	0	0	0	0	0	1	0	0
31 250 to 31 350			0	1	1	0	0	0	0	1	1	0	0
31 350 to 31 450			0	1	1	0	0	0	0	1	1	1	0
31 450 to 31 550			0	1	1	0	0	0	0	1	0	1	0
31 550 to 31 650			0	1	1	0	0	0	0	1	0	1	1
31 650 to 31 750			0	1	1	0	0	0	0	1	0	0	1
31 750 to 31 850			0	1	1	0	0	0	1	1	0	0	1
31 850 to 31 950			0	1	1	0	0	0	1	1	0	1	1
31 950 to 32 050			0	1	1	0	0	0	1	1	0	1	0
32 050 to 32 150			0	1	1	0	0	0	1	1	1	1	0
32 150 to 32 250			0	1	1	0	0	0	1	1	1	0	0
32 250 to 32 350			0	1	1	0	0	0	1	0	1	0	0
32 350 to 32 450			0	1	1	0	0	0	1	0	1	1	0
32 450 to 32 550			0	1	1	0	0	0	1	0	0	1	0
32 550 to 32 650			0	1	1	0	0	0	1	0	0	1	1
32 650 to 32 750			0	1	1	0	0	0	1	0	0	0	1
32 750 to 32 850			0	1	1	0	0	1	1	0	0	0	1
32 850 to 32 950			0	1	1	0	0	1	1	0	0	1	1
32 950 to 33 050			0	1	1	0	0	1	1	0	0	1	0
33 050 to 33 150			0	1	1	0	0	1	1	0	1	1	0
33 150 to 33 250			0	1	1	0	0	1	1	0	1	0	0
33 250 to 33 350			0	1	1	0	0	1	1	1	1	0	0
33 350 to 33 450			0	1	1	0	0	1	1	1	1	1	0
33 450 to 33 550			0	1	1	0	0	1	1	1	0	1	0
33 550 to 33 650			0	1	1	0	0	1	1	1	0	1	1
33 650 to 33 750			0	1	1	0	0	1	1	1	0	0	1
33 750 to 33 850			0	1	1	0	0	1	0	1	0	0	1
33 850 to 33 950			0	1	1	0	0	1	0	1	0	1	1
33 950 to 34 050			0	1	1	0	0	1	0	1	0	1	0
34 050 to 34 150			0	1	1	0	0	1	0	1	1	1	0
34 150 to 34 250			0	1	1	0	0	1	0	1	1	0	0

RANGE	PULSE POSITIONS (0 or 1 in a pulse position denotes absence or presence of a pulse, respectively)													
	Increments (Feet)			D <sub>2</sub>	D <sub>4</sub>	A <sub>1</sub>	A <sub>2</sub>	A <sub>4</sub>	B <sub>1</sub>	B <sub>2</sub>	B <sub>4</sub>	C <sub>1</sub>	C <sub>2</sub>	C <sub>4</sub>
34 250 to 34 350	0	1	1	0	0	1	0	0	1	0	0	1	0	0
34 350 to 34 450	0	1	1	0	0	1	0	0	1	0	0	1	1	0
34 450 to 34 550	0	1	1	0	0	1	0	0	1	0	0	0	1	0
34 550 to 34 650	0	1	1	0	0	1	0	0	1	0	0	0	1	1
34 650 to 34 750	0	1	1	0	0	1	0	0	1	0	0	0	0	1
34 750 to 34 850	0	1	1	0	1	1	1	0	0	0	0	0	0	1
34 850 to 34 950	0	1	1	0	1	1	1	0	0	0	0	0	1	1
34 950 to 35 050	0	1	1	0	1	1	1	0	0	0	0	0	1	0
35 050 to 35 150	0	1	1	0	1	1	1	0	0	0	1	1	1	0
35 150 to 35 250	0	1	1	0	1	1	1	0	0	0	1	1	0	0
35 250 to 35 350	0	1	1	0	1	1	1	0	1	0	1	1	0	0
35 350 to 35 450	0	1	1	0	1	1	1	0	1	0	1	1	1	0
35 450 to 35 550	0	1	1	0	1	1	1	0	1	0	1	0	1	0
35 550 to 35 650	0	1	1	0	1	1	1	0	1	0	1	0	1	1
35 650 to 35 750	0	1	1	0	1	1	1	0	1	0	1	0	0	1
35 750 to 35 850	0	1	1	0	1	1	1	1	1	1	0	0	0	1
35 850 to 35 950	0	1	1	0	1	1	1	1	1	1	0	0	1	1
35 950 to 36 050	0	1	1	0	1	1	1	1	1	1	0	0	1	0
36 050 to 36 150	0	1	1	0	1	1	1	1	1	1	1	1	1	0
36 150 to 36 250	0	1	1	0	1	1	1	1	1	1	1	1	0	0
36 250 to 36 350	0	1	1	0	1	1	1	1	0	0	1	1	0	0
36 350 to 36 450	0	1	1	0	1	1	1	1	0	0	1	1	1	0
36 450 to 36 550	0	1	1	0	1	1	1	1	0	0	1	0	1	0
36 550 to 36 650	0	1	1	0	1	1	1	1	0	0	1	0	1	1
36 650 to 36 750	0	1	1	0	1	1	1	1	0	0	1	0	0	1
36 750 to 36 850	0	1	1	0	1	0	1	0	0	0	0	0	0	1
36 850 to 36 950	0	1	1	0	1	0	1	0	1	0	0	0	1	1
36 950 to 37 050	0	1	1	0	1	0	1	0	1	0	0	0	1	0
37 050 to 37 150	0	1	1	0	1	0	1	0	1	0	1	1	1	0
37 150 to 37 250	0	1	1	0	1	0	1	0	1	0	1	1	0	0
37 250 to 37 350	0	1	1	0	1	0	1	0	1	1	1	1	0	0
37 350 to 37 450	0	1	1	0	1	0	1	0	1	1	1	1	1	0
37 450 to 37 550	0	1	1	0	1	0	1	0	1	1	0	1	1	0
37 550 to 37 650	0	1	1	0	1	0	1	0	1	1	0	1	1	1
37 650 to 37 750	0	1	1	0	1	0	1	0	1	1	0	0	0	1
37 750 to 37 850	0	1	1	0	1	0	0	0	1	0	0	0	0	1
37 850 to 37 950	0	1	1	0	1	0	0	0	1	0	0	0	1	1
37 950 to 38 050	0	1	1	0	1	0	0	0	1	0	0	0	1	0
38 050 to 38 150	0	1	1	0	1	0	0	0	1	0	0	1	1	0
38 150 to 38 250	0	1	1	0	1	0	0	0	1	0	0	1	0	0
38 250 to 38 350	0	1	1	0	1	0	0	0	0	0	0	1	0	0
38 350 to 38 450	0	1	1	0	1	0	0	0	0	0	0	1	1	0
38 450 to 38 550	0	1	1	0	1	0	0	0	0	0	0	0	1	0
38 550 to 38 650	0	1	1	0	1	0	0	0	0	0	0	0	1	1
38 650 to 38 750	0	1	1	0	1	0	0	0	0	0	0	0	0	1

RANGE	PULSE POSITIONS (0 or 1 in a pulse position denotes absence or presence of a pulse, respectively)												
	Increments (Feet)		D <sub>2</sub>	D <sub>4</sub>	A <sub>1</sub>	A <sub>2</sub>	A <sub>4</sub>	B <sub>1</sub>	B <sub>2</sub>	B <sub>4</sub>	C <sub>1</sub>	C <sub>2</sub>	C <sub>4</sub>
38 750 to 38 850			0	1	1	1	1	0	0	0	0	0	1
38 850 to 38 950			0	1	1	1	1	0	0	0	0	1	1
38 950 to 39 050			0	1	1	1	1	0	0	0	0	1	0
39 050 to 39 150			0	1	1	1	1	0	0	0	1	1	0
39 150 to 39 250			0	1	1	1	1	0	0	0	1	0	0
39 250 to 39 350			0	1	1	1	1	0	0	1	1	0	0
39 350 to 39 450			0	1	1	1	1	0	0	1	1	1	0
39 450 to 39 550			0	1	1	1	1	0	0	1	0	1	0
39 550 to 39 650			0	1	1	1	1	0	0	1	0	1	1
39 650 to 39 750			0	1	1	1	1	0	0	1	0	0	1
39 750 to 39 850			0	1	1	1	1	0	1	1	0	0	1
39 850 to 39 950			0	1	1	1	1	0	1	1	0	1	1
39 950 to 40 050			0	1	1	1	1	0	1	1	0	1	0
40 050 to 40 150			0	1	1	1	1	0	1	1	1	1	0
40 150 to 40 250			0	1	1	1	1	0	1	1	1	0	0
40 250 to 40 350			0	1	1	1	1	0	1	0	1	0	0
40 350 to 40 450			0	1	1	1	1	0	1	0	1	1	0
40 450 to 40 550			0	1	1	1	1	0	1	0	0	1	0
40 550 to 40 650			0	1	1	1	1	0	1	0	0	1	1
40 650 to 40 750			0	1	1	1	1	0	1	0	0	0	1
40 750 to 40 850			0	1	1	1	1	1	1	0	0	0	1
40 850 to 40 950			0	1	1	1	1	1	1	0	0	1	1
40 950 to 41 050			0	1	1	1	1	1	1	0	0	1	0
41 050 to 41 150			0	1	1	1	1	1	1	0	1	1	0
41 150 to 41 250			0	1	1	1	1	1	1	0	1	0	0
41 250 to 41 350			0	1	1	1	1	1	1	1	1	0	0
41 350 to 41 450			0	1	1	1	1	1	1	1	1	1	0
41 450 to 41 550			0	1	1	1	1	1	1	1	0	1	0
41 550 to 41 650			0	1	1	1	1	1	1	1	0	1	1
41 650 to 41 750			0	1	1	1	1	1	1	1	0	0	1
41 750 to 41 850			0	1	1	1	1	1	0	1	0	0	1
41 850 to 41 950			0	1	1	1	1	1	0	1	0	1	1
41 950 to 42 050			0	1	1	1	1	1	0	1	0	1	0
42 050 to 42 150			0	1	1	1	1	1	0	1	1	1	0
42 150 to 42 250			0	1	1	1	1	1	0	1	1	0	0
42 250 to 42 350			0	1	1	1	1	1	0	0	1	0	0
42 350 to 42 450			0	1	1	1	1	1	0	0	1	1	0
42 450 to 42 550			0	1	1	1	1	1	0	0	0	1	0
42 550 to 42 650			0	1	1	1	1	1	0	0	0	1	1
42 650 to 42 750			0	1	1	1	1	1	0	0	0	0	1
42 750 to 42 850			0	1	1	1	0	1	0	0	0	0	1
42 850 to 42 950			0	1	1	1	0	1	0	0	0	1	1
42 950 to 43 050			0	1	1	1	0	1	0	0	0	1	0
43 050 to 43 150			0	1	1	1	0	1	0	0	1	1	0
43 150 to 43 250			0	1	1	1	0	1	0	0	1	0	0

RANGE	PULSE POSITIONS (0 or 1 in a pulse position denotes absence or presence of a pulse, respectively)										
	Increments (Feet)	D <sub>2</sub>	D <sub>4</sub>	A <sub>1</sub>	A <sub>2</sub>	A <sub>4</sub>	B <sub>1</sub>	B <sub>2</sub>	B <sub>4</sub>	C <sub>1</sub>	C <sub>2</sub>
43 250 to 43 350	0	1	1	1	0	1	0	1	1	0	0
43 350 to 43 450	0	1	1	1	0	1	0	1	1	1	0
43 450 to 43 550	0	1	1	1	0	1	0	1	0	1	0
43 550 to 43 650	0	1	1	1	0	1	0	1	0	1	1
43 650 to 43 750	0	1	1	1	0	1	0	1	0	0	1
43 750 to 43 850	0	1	1	1	0	1	1	1	0	0	1
43 850 to 43 950	0	1	1	1	0	1	1	1	0	1	1
43 950 to 44 050	0	1	1	1	0	1	1	1	0	1	0
44 050 to 44 150	0	1	1	1	0	1	1	1	1	1	0
44 150 to 44 250	0	1	1	1	0	1	1	1	1	0	0
44 250 to 44 350	0	1	1	1	0	1	1	0	1	0	0
44 350 to 44 450	0	1	1	1	0	1	1	0	1	1	0
44 450 to 44 550	0	1	1	1	0	1	1	0	0	1	0
44 550 to 44 650	0	1	1	1	0	1	1	0	0	1	1
44 650 to 44 750	0	1	1	1	0	1	1	0	0	0	1
44 750 to 44 850	0	1	1	1	0	0	1	0	0	0	1
44 850 to 44 950	0	1	1	1	0	0	1	0	0	1	1
44 950 to 45 050	0	1	1	1	0	0	1	0	0	1	0
45 050 to 45 150	0	1	1	1	0	0	1	0	1	1	0
45 150 to 45 250	0	1	1	1	0	0	1	0	1	0	0
45 250 to 45 350	0	1	1	1	0	0	1	1	1	0	0
45 350 to 45 450	0	1	1	1	0	0	1	1	1	1	0
45 450 to 45 550	0	1	1	1	0	0	1	1	0	1	0
45 550 to 45 650	0	1	1	1	0	0	1	1	0	1	1
45 650 to 45 750	0	1	1	1	0	0	1	1	0	0	1
45 750 to 45 850	0	1	1	1	0	0	0	1	0	0	1
45 850 to 45 950	0	1	1	1	0	0	0	1	0	1	1
45 950 to 46 050	0	1	1	1	0	0	0	1	0	1	0
46 050 to 46 150	0	1	1	1	0	0	0	1	1	1	0
46 150 to 46 250	0	1	1	1	0	0	0	1	1	0	0
46 250 to 46 350	0	1	1	1	0	0	0	0	1	0	0
46 350 to 46 450	0	1	1	1	0	0	0	0	1	1	0
46 450 to 46 550	0	1	1	1	0	0	0	0	0	1	0
46 550 to 46 650	0	1	1	1	0	0	0	0	0	1	1
46 650 to 46 750	0	1	1	1	0	0	0	0	0	0	1
46 750 to 46 850	0	1	0	1	0	0	0	0	0	0	1
46 850 to 46 950	0	1	0	1	0	0	0	0	0	1	1
46 950 to 47 050	0	1	0	1	0	0	0	0	0	1	0
47 050 to 47 150	0	1	0	1	0	0	0	0	1	1	0
47 150 to 47 250	0	1	0	1	0	0	0	0	1	0	0
47 250 to 47 350	0	1	0	1	0	0	0	1	1	0	0
47 350 to 47 450	0	1	0	1	0	0	0	1	1	1	0
47 450 to 47 550	0	1	0	1	0	0	0	1	0	1	0
47 550 to 47 650	0	1	0	1	0	0	0	1	0	1	1
47 650 to 47 750	0	1	0	1	0	0	0	1	0	0	1

RANGE	PULSE POSITIONS (0 or 1 in a pulse position denotes absence or presence of a pulse, respectively)										
	Increments (Feet)	D <sub>2</sub>	D <sub>4</sub>	A <sub>1</sub>	A <sub>2</sub>	A <sub>4</sub>	B <sub>1</sub>	B <sub>2</sub>	B <sub>4</sub>	C <sub>1</sub>	C <sub>2</sub>
47 750 to 47 850	0	1	0	1	0	0	1	1	0	0	1
47 850 to 47 950	0	1	0	1	0	0	1	1	0	1	1
47 950 to 48 050	0	1	0	1	0	0	1	1	0	1	0
48 050 to 48 150	0	1	0	1	0	0	1	1	1	1	0
48 150 to 48 250	0	1	0	1	0	0	1	1	1	0	0
48 250 to 48 350	0	1	0	1	0	0	1	0	1	0	0
48 350 to 48 450	0	1	0	1	0	0	1	0	1	1	0
48 450 to 48 550	0	1	0	1	0	0	1	0	0	1	0
48 550 to 48 650	0	1	0	1	0	0	1	0	0	1	1
48 650 to 48 750	0	1	0	1	0	0	1	0	0	0	1
48 750 to 48 850	0	1	0	1	0	1	1	0	0	0	1
48 850 to 48 950	0	1	0	1	0	1	1	0	0	1	1
48 950 to 49 050	0	1	0	1	0	1	1	0	0	1	0
49 050 to 49 150	0	1	0	1	0	1	1	0	1	1	0
49 150 to 49 250	0	1	0	1	0	1	1	0	1	0	0
49 250 to 49 350	0	1	0	1	0	1	1	1	1	0	0
49 350 to 49 450	0	1	0	1	0	1	1	1	1	1	0
49 450 to 49 550	0	1	0	1	0	1	1	1	0	1	0
49 550 to 49 650	0	1	0	1	0	1	1	1	0	1	1
49 650 to 49 750	0	1	0	1	0	1	1	1	0	0	1
49 750 to 49 850	0	1	0	1	0	1	0	1	0	0	1
49 850 to 49 950	0	1	0	1	0	1	0	1	0	1	1
49 950 to 50 050	0	1	0	1	0	1	0	1	0	1	0
50 050 to 50 150	0	1	0	1	0	1	0	1	1	1	0
50 150 to 50 250	0	1	0	1	0	1	0	1	1	0	0
50 250 to 50 350	0	1	0	1	0	1	0	0	1	0	0
50 350 to 50 450	0	1	0	1	0	1	0	0	1	1	0
50 450 to 50 550	0	1	0	1	0	1	0	0	0	1	0
50 550 to 50 650	0	1	0	1	0	1	0	0	0	1	1
50 650 to 50 750	0	1	0	1	0	1	0	0	0	0	1
50 750 to 50 850	0	1	0	1	1	1	0	0	0	0	1
50 850 to 50 950	0	1	0	1	1	1	0	0	0	1	1
50 950 to 51 050	0	1	0	1	1	1	0	0	0	1	0
51 050 to 51 150	0	1	0	1	1	1	0	0	1	1	0
51 150 to 51 250	0	1	0	1	1	1	0	0	1	0	0
51 250 to 51 350	0	1	0	1	1	1	0	1	1	0	0
51 350 to 51 450	0	1	0	1	1	1	0	1	1	1	0
51 450 to 51 550	0	1	0	1	1	1	0	1	0	1	0
51 550 to 51 650	0	1	0	1	1	1	0	1	0	1	1
51 650 to 51 750	0	1	0	1	1	1	0	1	0	0	1
51 750 to 51 850	0	1	0	1	1	1	1	1	0	0	1
51 850 to 51 950	0	1	0	1	1	1	1	1	0	1	1
51 950 to 52 050	0	1	0	1	1	1	1	1	0	1	0
52 050 to 52 150	0	1	0	1	1	1	1	1	1	1	0
52 150 to 52 250	0	1	0	1	1	1	1	1	1	0	0



RANGE	PULSE POSITIONS (0 or 1 in a pulse position denotes absence or presence of a pulse, respectively)											
	Increments (Feet)	D <sub>2</sub>	D <sub>4</sub>	A <sub>1</sub>	A <sub>2</sub>	A <sub>4</sub>	B <sub>1</sub>	B <sub>2</sub>	B <sub>4</sub>	C <sub>1</sub>	C <sub>2</sub>	C <sub>4</sub>
52 250 to 52 350	0	1	0	1	1	1	1	1	0	1	0	0
52 350 to 52 450	0	1	0	1	1	1	1	1	0	1	1	0
52 450 to 52 550	0	1	0	1	1	1	1	1	0	0	1	0
52 550 to 52 650	0	1	0	1	1	1	1	1	0	0	1	1
52 650 to 52 750	0	1	0	1	1	1	1	1	0	0	0	1
52 750 to 52 850	0	1	0	1	1	0	1	0	0	0	0	1
52 850 to 52 950	0	1	0	1	1	0	1	0	0	0	1	1
52 950 to 53 050	0	1	0	1	1	0	1	0	0	0	1	0
53 050 to 53 150	0	1	0	1	1	0	1	0	0	1	1	0
53 150 to 53 250	0	1	0	1	1	0	1	0	0	1	0	0
53 250 to 53 350	0	1	0	1	1	0	1	1	1	1	0	0
53 350 to 53 450	0	1	0	1	1	0	1	1	1	1	1	0
53 450 to 53 550	0	1	0	1	1	0	1	1	1	0	1	0
53 550 to 53 650	0	1	0	1	1	0	1	1	1	0	1	1
53 650 to 53 750	0	1	0	1	1	0	1	1	1	0	0	1
53 750 to 53 850	0	1	0	1	1	0	0	0	1	0	0	1
53 850 to 53 950	0	1	0	1	1	0	0	0	1	0	1	1
53 950 to 54 050	0	1	0	1	1	0	0	0	1	0	1	0
54 050 to 54 150	0	1	0	1	1	0	0	0	1	1	1	0
54 150 to 54 250	0	1	0	1	1	0	0	0	1	1	0	0
54 250 to 54 350	0	1	0	1	1	0	0	0	0	1	0	0
54 350 to 54 450	0	1	0	1	1	0	0	0	0	1	1	0
54 450 to 54 550	0	1	0	1	1	0	0	0	0	0	1	0
54 550 to 54 650	0	1	0	1	1	0	0	0	0	0	1	1
54 650 to 54 750	0	1	0	1	1	0	0	0	0	0	0	1
54 750 to 54 850	0	1	0	0	1	0	0	0	0	0	0	1
54 850 to 54 950	0	1	0	0	1	0	0	0	0	0	1	1
54 950 to 55 050	0	1	0	0	1	0	0	0	0	0	1	0
55 050 to 55 150	0	1	0	0	1	0	0	0	0	1	1	0
55 150 to 55 250	0	1	0	0	1	0	0	0	0	1	0	0
55 250 to 55 350	0	1	0	0	1	0	0	0	1	1	0	0
55 350 to 55 450	0	1	0	0	1	0	0	0	1	1	1	0
55 450 to 55 550	0	1	0	0	1	0	0	0	1	0	1	0
55 550 to 55 650	0	1	0	0	1	0	0	0	1	0	1	1
55 650 to 55 750	0	1	0	0	1	0	0	0	1	0	0	1
55 750 to 55 850	0	1	0	0	1	0	1	1	1	0	0	1
55 850 to 55 950	0	1	0	0	1	0	1	1	1	0	1	1
55 950 to 56 050	0	1	0	0	1	0	1	1	1	0	1	0
56 050 to 56 150	0	1	0	0	1	0	1	1	1	1	1	0
56 150 to 56 250	0	1	0	0	1	0	1	1	1	1	0	0
56 250 to 56 350	0	1	0	0	1	0	1	0	0	1	0	0
56 350 to 56 450	0	1	0	0	1	0	1	0	0	1	1	0
56 450 to 56 550	0	1	0	0	1	0	1	0	0	0	1	0
56 550 to 56 650	0	1	0	0	1	0	1	0	0	0	1	1
56 650 to 56 750	0	1	0	0	1	0	1	0	0	0	0	1

RANGE	PULSE POSITIONS (0 or 1 in a pulse position denotes absence or presence of a pulse, respectively)										
	Increments (Feet)	D <sub>2</sub>	D <sub>4</sub>	A <sub>1</sub>	A <sub>2</sub>	A <sub>4</sub>	B <sub>1</sub>	B <sub>2</sub>	B <sub>4</sub>	C <sub>1</sub>	C <sub>2</sub>
56 750 to 56 850	0	1	0	0	1	1	1	0	0	0	1
56 850 to 56 950	0	1	0	0	1	1	1	0	0	1	1
56 950 to 57 050	0	1	0	0	1	1	1	0	0	1	0
57 050 to 57 150	0	1	0	0	1	1	1	0	1	1	0
57 150 to 57 250	0	1	0	0	1	1	1	0	1	0	0
57 250 to 57 350	0	1	0	0	1	1	1	1	1	0	0
57 350 to 57 450	0	1	0	0	1	1	1	1	1	1	0
57 450 to 57 550	0	1	0	0	1	1	1	1	0	1	0
57 550 to 57 650	0	1	0	0	1	1	1	1	0	1	1
57 650 to 57 750	0	1	0	0	1	1	1	1	0	0	1
57 750 to 57 850	0	1	0	0	1	1	0	1	0	0	1
57 850 to 57 950	0	1	0	0	1	1	0	1	0	1	1
57 950 to 58 050	0	1	0	0	1	1	0	1	0	1	0
58 050 to 58 150	0	1	0	0	1	1	0	1	1	1	0
58 150 to 58 250	0	1	0	0	1	1	0	1	1	0	0
58 250 to 58 350	0	1	0	0	1	1	0	0	1	0	0
58 350 to 58 450	0	1	0	0	1	1	0	0	1	1	0
58 450 to 58 550	0	1	0	0	1	1	0	0	0	1	0
58 550 to 58 650	0	1	0	0	1	1	0	0	0	1	1
58 650 to 58 750	0	1	0	0	1	1	0	0	0	0	1
58 750 to 58 850	0	1	0	0	0	1	0	0	0	0	1
58 850 to 58 950	0	1	0	0	0	1	0	0	0	1	1
58 950 to 59 050	0	1	0	0	0	1	0	0	0	1	0
59 050 to 59 150	0	1	0	0	0	1	0	0	1	1	0
59 150 to 59 250	0	1	0	0	0	1	0	0	1	0	0
59 250 to 59 350	0	1	0	0	0	1	0	1	1	0	0
59 350 to 59 450	0	1	0	0	0	1	0	1	1	1	0
59 450 to 59 550	0	1	0	0	0	1	0	1	0	1	0
59 550 to 59 650	0	1	0	0	0	1	0	1	0	1	1
59 650 to 59 750	0	1	0	0	0	1	0	1	0	0	1
59 750 to 59 850	0	1	0	0	0	1	1	1	0	0	1
59 850 to 59 950	0	1	0	0	0	1	1	1	0	1	1
59 950 to 60 050	0	1	0	0	0	1	1	1	0	1	0
60 050 to 60 150	0	1	0	0	0	1	1	1	1	1	0
60 150 to 60 250	0	1	0	0	0	1	1	1	1	0	0
60 250 to 60 350	0	1	0	0	0	1	1	0	1	0	0
60 350 to 60 450	0	1	0	0	0	1	1	0	1	1	0
60 450 to 60 550	0	1	0	0	0	1	1	0	0	1	0
60 550 to 60 650	0	1	0	0	0	1	1	0	0	1	1
60 650 to 60 750	0	1	0	0	0	1	1	0	0	0	1
60 750 to 60 850	0	1	0	0	0	0	1	0	0	0	1
60 850 to 60 950	0	1	0	0	0	0	1	0	0	1	1
60 950 to 61 050	0	1	0	0	0	0	1	0	0	1	0
61 050 to 61 150	0	1	0	0	0	0	1	0	1	1	0
61 150 to 61 250	0	1	0	0	0	0	1	0	1	0	0

RANGE	PULSE POSITIONS (0 or 1 in a pulse position denotes absence or presence of a pulse, respectively)											
	Increments (Feet)	D <sub>2</sub>	D <sub>4</sub>	A <sub>1</sub>	A <sub>2</sub>	A <sub>4</sub>	B <sub>1</sub>	B <sub>2</sub>	B <sub>4</sub>	C <sub>1</sub>	C <sub>2</sub>	C <sub>4</sub>
61 250 to 61 350	0	1	0	0	0	0	0	1	1	1	0	0
61 350 to 61 450	0	1	0	0	0	0	0	1	1	1	1	0
61 450 to 61 550	0	1	0	0	0	0	0	1	1	0	1	0
61 550 to 61 650	0	1	0	0	0	0	0	1	1	0	1	1
61 650 to 61 750	0	1	0	0	0	0	0	1	1	0	0	1
61 750 to 61 850	0	1	0	0	0	0	0	0	1	0	0	1
61 850 to 61 950	0	1	0	0	0	0	0	0	1	0	1	1
61 950 to 62 050	0	1	0	0	0	0	0	0	1	0	1	0
62 050 to 62 150	0	1	0	0	0	0	0	0	1	1	1	0
62 150 to 62 250	0	1	0	0	0	0	0	0	1	1	0	0
62 250 to 62 350	0	1	0	0	0	0	0	0	0	1	0	0
62 350 to 62 450	0	1	0	0	0	0	0	0	0	1	1	0
62 450 to 62 550	0	1	0	0	0	0	0	0	0	0	1	0
62 550 to 62 650	0	1	0	0	0	0	0	0	0	0	1	1
62 650 to 62 750	0	1	0	0	0	0	0	0	0	0	0	1
62 750 to 62 850	1	1	0	0	0	0	0	0	0	0	0	1
62 850 to 62 950	1	1	0	0	0	0	0	0	0	0	1	1
62 950 to 63 050	1	1	0	0	0	0	0	0	0	0	1	0
63 050 to 63 150	1	1	0	0	0	0	0	0	0	1	1	0
63 150 to 63 250	1	1	0	0	0	0	0	0	0	1	0	0
63 250 to 63 350	1	1	0	0	0	0	0	0	1	1	0	0
63 350 to 63 450	1	1	0	0	0	0	0	0	1	1	1	0
63 450 to 63 550	1	1	0	0	0	0	0	0	1	0	1	0
63 550 to 63 650	1	1	0	0	0	0	0	0	1	0	1	1
63 650 to 63 750	1	1	0	0	0	0	0	0	1	0	0	1
63 750 to 63 850	1	1	0	0	0	0	0	1	1	0	0	1
63 850 to 63 950	1	1	0	0	0	0	0	1	1	0	1	1
63 950 to 64 050	1	1	0	0	0	0	0	1	1	0	1	0
64 050 to 64 150	1	1	0	0	0	0	0	1	1	1	1	0
64 150 to 64 250	1	1	0	0	0	0	0	1	1	1	0	0
64 250 to 64 350	1	1	0	0	0	0	0	1	0	1	0	0
64 350 to 64 450	1	1	0	0	0	0	0	1	0	1	1	0
64 450 to 64 550	1	1	0	0	0	0	0	1	0	0	1	0
64 550 to 64 650	1	1	0	0	0	0	0	1	0	0	1	1
64 650 to 64 750	1	1	0	0	0	0	0	1	0	0	0	1
64 750 to 64 850	1	1	0	0	0	0	1	1	0	0	0	1
64 850 to 64 950	1	1	0	0	0	0	1	1	0	0	1	1
64 950 to 65 050	1	1	0	0	0	0	1	1	0	0	1	0
65 050 to 65 150	1	1	0	0	0	0	1	1	0	1	1	0
65 150 to 65 250	1	1	0	0	0	0	1	1	0	1	0	0
65 250 to 65 350	1	1	0	0	0	0	1	1	1	1	0	0
65 350 to 65 450	1	1	0	0	0	0	1	1	1	1	1	0
65 450 to 65 550	1	1	0	0	0	0	1	1	1	0	1	0
65 550 to 65 650	1	1	0	0	0	0	1	1	1	0	1	1
65 650 to 65 750	1	1	0	0	0	0	1	1	1	0	0	1

RANGE	PULSE POSITIONS (0 or 1 in a pulse position denotes absence or presence of a pulse, respectively)											
	Increments (Feet)	D <sub>2</sub>	D <sub>4</sub>	A <sub>1</sub>	A <sub>2</sub>	A <sub>4</sub>	B <sub>1</sub>	B <sub>2</sub>	B <sub>4</sub>	C <sub>1</sub>	C <sub>2</sub>	C <sub>4</sub>
65 750 to 65 850	1	1	0	0	0	1	0	1	0	0	0	1
65 850 to 65 950	1	1	0	0	0	1	0	1	0	0	1	1
65 950 to 66 050	1	1	0	0	0	1	0	1	0	0	1	0
66 050 to 66 150	1	1	0	0	0	1	0	1	0	1	1	0
66 150 to 66 250	1	1	0	0	0	1	0	1	0	1	0	0
66 250 to 66 350	1	1	0	0	0	1	0	0	0	1	0	0
66 350 to 66 450	1	1	0	0	0	1	0	0	0	1	1	0
66 450 to 66 550	1	1	0	0	0	1	0	0	0	0	1	0
66 550 to 66 650	1	1	0	0	0	1	0	0	0	0	1	1
66 650 to 66 750	1	1	0	0	0	1	0	0	0	0	0	1
66 750 to 66 850	1	1	0	0	1	1	0	0	0	0	0	1
66 850 to 66 950	1	1	0	0	1	1	0	0	0	0	1	1
66 950 to 67 050	1	1	0	0	1	1	0	0	0	0	1	0
67 050 to 67 150	1	1	0	0	1	1	0	0	0	1	1	0
67 150 to 67 250	1	1	0	0	1	1	0	0	0	1	0	0
67 250 to 67 350	1	1	0	0	1	1	0	1	0	1	0	0
67 350 to 67 450	1	1	0	0	1	1	0	1	0	1	1	0
67 450 to 67 550	1	1	0	0	1	1	0	1	0	0	1	0
67 550 to 67 650	1	1	0	0	1	1	0	1	0	0	1	1
67 650 to 67 750	1	1	0	0	1	1	0	1	0	0	0	1
67 750 to 67 850	1	1	0	0	1	1	1	1	1	0	0	1
67 850 to 67 950	1	1	0	0	1	1	1	1	1	0	1	1
67 950 to 68 050	1	1	0	0	1	1	1	1	1	0	1	0
68 050 to 68 150	1	1	0	0	1	1	1	1	1	1	1	0
68 150 to 68 250	1	1	0	0	1	1	1	1	1	1	0	0
68 250 to 68 350	1	1	0	0	1	1	1	0	0	1	0	0
68 350 to 68 450	1	1	0	0	1	1	1	0	0	1	1	0
68 450 to 68 550	1	1	0	0	1	1	1	0	0	0	1	0
68 550 to 68 650	1	1	0	0	1	1	1	0	0	0	1	1
68 650 to 68 750	1	1	0	0	1	1	1	0	0	0	0	1
68 750 to 68 850	1	1	0	0	1	0	1	0	0	0	0	1
68 850 to 68 950	1	1	0	0	1	0	1	0	0	0	1	1
68 950 to 69 050	1	1	0	0	1	0	1	0	0	0	1	0
69 050 to 69 150	1	1	0	0	1	0	1	0	0	1	1	0
69 150 to 69 250	1	1	0	0	1	0	1	0	0	1	0	0
69 250 to 69 350	1	1	0	0	1	0	1	1	0	1	0	0
69 350 to 69 450	1	1	0	0	1	0	1	1	0	1	1	0
69 450 to 69 550	1	1	0	0	1	0	1	1	0	0	1	0
69 550 to 69 650	1	1	0	0	1	0	1	1	0	0	1	1
69 650 to 69 750	1	1	0	0	1	0	1	1	0	0	0	1
69 750 to 69 850	1	1	0	0	1	0	0	1	0	0	0	1
69 850 to 69 950	1	1	0	0	1	0	0	1	0	0	1	1
69 950 to 70 050	1	1	0	0	1	0	0	1	0	0	1	0
70 050 to 70 150	1	1	0	0	1	0	0	1	0	1	1	0
70 150 to 70 250	1	1	0	0	1	0	0	1	0	1	0	0

RANGE	PULSE POSITIONS (0 or 1 in a pulse position denotes absence or presence of a pulse, respectively)										
	Increments (Feet)	D <sub>2</sub>	D <sub>4</sub>	A <sub>1</sub>	A <sub>2</sub>	A <sub>4</sub>	B <sub>1</sub>	B <sub>2</sub>	B <sub>4</sub>	C <sub>1</sub>	C <sub>2</sub>
70 250 to 70 350	1	1	0	0	1	0	0	0	1	0	0
70 350 to 70 450	1	1	0	0	1	0	0	0	1	1	0
70 450 to 70 550	1	1	0	0	1	0	0	0	0	1	0
70 550 to 70 650	1	1	0	0	1	0	0	0	0	1	1
70 650 to 70 750	1	1	0	0	1	0	0	0	0	0	1
70 750 to 70 850	1	1	0	1	1	0	0	0	0	0	1
70 850 to 70 950	1	1	0	1	1	0	0	0	0	1	1
70 950 to 71 050	1	1	0	1	1	0	0	0	0	1	0
71 050 to 71 150	1	1	0	1	1	0	0	0	1	1	0
71 150 to 71 250	1	1	0	1	1	0	0	0	1	0	0
71 250 to 71 350	1	1	0	1	1	0	0	1	1	0	0
71 350 to 71 450	1	1	0	1	1	0	0	1	1	1	0
71 450 to 71 550	1	1	0	1	1	0	0	1	0	1	0
71 550 to 71 650	1	1	0	1	1	0	0	1	0	1	1
71 650 to 71 750	1	1	0	1	1	0	0	1	0	0	1
71 750 to 71 850	1	1	0	1	1	0	1	1	0	0	1
71 850 to 71 950	1	1	0	1	1	0	1	1	0	1	1
71 950 to 72 050	1	1	0	1	1	0	1	1	0	1	0
72 050 to 72 150	1	1	0	1	1	0	1	1	1	1	0
72 150 to 72 250	1	1	0	1	1	0	1	1	1	0	0
72 250 to 72 350	1	1	0	1	1	0	1	0	1	0	0
72 350 to 72 450	1	1	0	1	1	0	1	0	1	1	0
72 450 to 72 550	1	1	0	1	1	0	1	0	0	1	0
72 550 to 72 650	1	1	0	1	1	0	1	0	0	1	1
72 650 to 72 750	1	1	0	1	1	0	1	0	0	0	1
72 750 to 72 850	1	1	0	1	1	1	1	0	0	0	1
72 850 to 72 950	1	1	0	1	1	1	1	0	0	1	1
72 950 to 73 050	1	1	0	1	1	1	1	0	0	1	0
73 050 to 73 150	1	1	0	1	1	1	1	0	1	1	0
73 150 to 73 250	1	1	0	1	1	1	1	0	1	0	0
73 250 to 73 350	1	1	0	1	1	1	1	1	1	0	0
73 350 to 73 450	1	1	0	1	1	1	1	1	1	1	0
73 450 to 73 550	1	1	0	1	1	1	1	1	0	1	0
73 550 to 73 650	1	1	0	1	1	1	1	1	0	1	1
73 650 to 73 750	1	1	0	1	1	1	1	1	0	0	1
73 750 to 73 850	1	1	0	1	1	1	0	1	0	0	1
73 850 to 73 950	1	1	0	1	1	1	0	1	0	1	1
73 950 to 74 050	1	1	0	1	1	1	0	1	0	1	0
74 050 to 74 150	1	1	0	1	1	1	0	1	1	1	0
74 150 to 74 250	1	1	0	1	1	1	0	1	1	0	0
74 250 to 74 350	1	1	0	1	1	1	0	0	1	0	0
74 350 to 74 450	1	1	0	1	1	1	0	0	1	1	0
74 450 to 74 550	1	1	0	1	1	1	0	0	0	1	0
74 550 to 74 650	1	1	0	1	1	1	0	0	0	1	1
74 650 to 74 750	1	1	0	1	1	1	0	0	0	0	1

RANGE	PULSE POSITIONS (0 or 1 in a pulse position denotes absence or presence of a pulse, respectively)											
	Increments (Feet)	D <sub>2</sub>	D <sub>4</sub>	A <sub>1</sub>	A <sub>2</sub>	A <sub>4</sub>	B <sub>1</sub>	B <sub>2</sub>	B <sub>4</sub>	C <sub>1</sub>	C <sub>2</sub>	C <sub>4</sub>
74 750 to 74 850	1	1	0	1	0	1	0	0	0	0	0	1
74 850 to 74 950	1	1	0	1	0	1	0	0	0	0	1	1
74 950 to 75 050	1	1	0	1	0	1	0	0	0	0	1	0
75 050 to 75 150	1	1	0	1	0	1	0	0	0	1	1	0
75 150 to 75 250	1	1	0	1	0	1	0	0	0	1	0	0
75 250 to 75 350	1	1	0	1	0	1	0	1	1	1	0	0
75 350 to 75 450	1	1	0	1	0	1	0	1	1	1	1	0
75 450 to 75 550	1	1	0	1	0	1	0	1	1	0	1	0
75 550 to 75 650	1	1	0	1	0	1	0	1	1	0	1	1
75 650 to 75 750	1	1	0	1	0	1	0	1	1	0	0	1
75 750 to 75 850	1	1	0	1	0	1	1	1	1	0	0	1
75 850 to 75 950	1	1	0	1	0	1	1	1	1	0	1	1
75 950 to 76 050	1	1	0	1	0	1	1	1	1	0	1	0
76 050 to 76 150	1	1	0	1	0	1	1	1	1	1	1	0
76 150 to 76 250	1	1	0	1	0	1	1	1	1	1	0	0
76 250 to 76 350	1	1	0	1	0	1	1	0	0	1	0	0
76 350 to 76 450	1	1	0	1	0	1	1	0	0	1	1	0
76 450 to 76 550	1	1	0	1	0	1	1	0	0	0	1	0
76 550 to 76 650	1	1	0	1	0	1	1	0	0	0	1	1
76 650 to 76 750	1	1	0	1	0	1	1	0	0	0	0	1
76 750 to 76 850	1	1	0	1	0	0	1	0	0	0	0	1
76 850 to 76 950	1	1	0	1	0	0	1	0	0	0	1	1
76 950 to 77 050	1	1	0	1	0	0	1	0	0	0	1	0
77 050 to 77 150	1	1	0	1	0	0	1	0	0	1	1	0
77 150 to 77 250	1	1	0	1	0	0	1	0	0	1	0	0
77 250 to 77 350	1	1	0	1	0	0	1	1	1	1	0	0
77 350 to 77 450	1	1	0	1	0	0	1	1	1	1	1	0
77 450 to 77 550	1	1	0	1	0	0	1	1	1	0	1	0
77 550 to 77 650	1	1	0	1	0	0	1	1	1	0	1	1
77 650 to 77 750	1	1	0	1	0	0	1	1	1	0	0	1
77 750 to 77 850	1	1	0	1	0	0	0	1	0	0	0	1
77 850 to 77 950	1	1	0	1	0	0	0	1	0	0	1	1
77 950 to 78 050	1	1	0	1	0	0	0	1	0	0	1	0
78 050 to 78 150	1	1	0	1	0	0	0	1	1	1	1	0
78 150 to 78 250	1	1	0	1	0	0	0	1	1	0	0	0
78 250 to 78 350	1	1	0	1	0	0	0	0	1	0	0	0
78 350 to 78 450	1	1	0	1	0	0	0	0	1	1	1	0
78 450 to 78 550	1	1	0	1	0	0	0	0	0	0	1	0
78 550 to 78 650	1	1	0	1	0	0	0	0	0	0	1	1
78 650 to 78 750	1	1	0	1	0	0	0	0	0	0	0	1
78 750 to 78 850	1	1	1	1	0	0	0	0	0	0	0	1
78 850 to 78 950	1	1	1	1	0	0	0	0	0	0	1	1
78 950 to 79 050	1	1	1	1	0	0	0	0	0	0	1	0
79 050 to 79 150	1	1	1	1	0	0	0	0	0	1	1	0
79 150 to 79 250	1	1	1	1	0	0	0	0	0	1	0	0

RANGE	PULSE POSITIONS (0 or 1 in a pulse position denotes absence or presence of a pulse, respectively)										
	Increments (Feet)	D <sub>2</sub>	D <sub>4</sub>	A <sub>1</sub>	A <sub>2</sub>	A <sub>4</sub>	B <sub>1</sub>	B <sub>2</sub>	B <sub>4</sub>	C <sub>1</sub>	C <sub>2</sub>
79 250 to 79 350	1	1	1	1	0	0	0	1	1	0	0
79 350 to 79 450	1	1	1	1	0	0	0	1	1	1	0
79 450 to 79 550	1	1	1	1	0	0	0	1	0	1	0
79 550 to 79 650	1	1	1	1	0	0	0	1	0	1	1
79 650 to 79 750	1	1	1	1	0	0	0	1	0	0	1
79 750 to 79 850	1	1	1	1	0	0	1	1	0	0	1
79 850 to 79 950	1	1	1	1	0	0	1	1	0	1	1
79 950 to 80 050	1	1	1	1	0	0	1	1	0	1	0
80 050 to 80 150	1	1	1	1	0	0	1	1	1	1	0
80 150 to 80 250	1	1	1	1	0	0	1	1	1	0	0
80 250 to 80 350	1	1	1	1	0	0	1	0	1	0	0
80 350 to 80 450	1	1	1	1	0	0	1	0	1	1	0
80 450 to 80 550	1	1	1	1	0	0	1	0	0	1	0
80 550 to 80 650	1	1	1	1	0	0	1	0	0	1	1
80 650 to 80 750	1	1	1	1	0	0	1	0	0	0	1
80 750 to 80 850	1	1	1	1	0	1	1	0	0	0	1
80 850 to 80 950	1	1	1	1	0	1	1	0	0	1	1
80 950 to 81 050	1	1	1	1	0	1	1	0	0	1	0
81 050 to 81 150	1	1	1	1	0	1	1	0	1	1	0
81 150 to 81 250	1	1	1	1	0	1	1	0	1	0	0
81 250 to 81 350	1	1	1	1	0	1	1	1	1	0	0
81 350 to 81 450	1	1	1	1	0	1	1	1	1	1	0
81 450 to 81 550	1	1	1	1	0	1	1	1	0	1	0
81 550 to 81 650	1	1	1	1	0	1	1	1	0	1	1
81 650 to 81 750	1	1	1	1	0	1	1	1	0	0	1
81 750 to 81 850	1	1	1	1	0	1	0	1	0	0	1
81 850 to 81 950	1	1	1	1	0	1	0	1	0	1	1
81 950 to 82 050	1	1	1	1	0	1	0	1	0	1	0
82 050 to 82 150	1	1	1	1	0	1	0	1	1	1	0
82 150 to 82 250	1	1	1	1	0	1	0	1	1	0	0
82 250 to 82 350	1	1	1	1	0	1	0	0	1	0	0
82 350 to 82 450	1	1	1	1	0	1	0	0	1	1	0
82 450 to 82 550	1	1	1	1	0	1	0	0	0	1	0
82 550 to 82 650	1	1	1	1	0	1	0	0	0	1	1
82 650 to 82 750	1	1	1	1	0	1	0	0	0	0	1
82 750 to 82 850	1	1	1	1	1	1	0	0	0	0	1
82 850 to 82 950	1	1	1	1	1	1	0	0	0	1	1
82 950 to 83 050	1	1	1	1	1	1	0	0	0	1	0
83 050 to 83 150	1	1	1	1	1	1	0	0	1	1	0
83 150 to 83 250	1	1	1	1	1	1	0	0	1	0	0
83 250 to 83 350	1	1	1	1	1	1	0	1	1	0	0
83 350 to 83 450	1	1	1	1	1	1	0	1	1	1	0
83 450 to 83 550	1	1	1	1	1	1	0	1	0	1	0
83 550 to 83 650	1	1	1	1	1	1	0	1	0	1	1
83 650 to 83 750	1	1	1	1	1	1	0	1	0	0	1

RANGE	PULSE POSITIONS (0 or 1 in a pulse position denotes absence or presence of a pulse, respectively)											
	Increments (Feet)	D <sub>2</sub>	D <sub>4</sub>	A <sub>1</sub>	A <sub>2</sub>	A <sub>4</sub>	B <sub>1</sub>	B <sub>2</sub>	B <sub>4</sub>	C <sub>1</sub>	C <sub>2</sub>	C <sub>4</sub>
83 750 to 83 850	1	1	1	1	1	1	1	1	1	0	0	1
83 850 to 83 950	1	1	1	1	1	1	1	1	1	0	1	1
83 950 to 84 050	1	1	1	1	1	1	1	1	1	0	1	0
84 050 to 84 150	1	1	1	1	1	1	1	1	1	1	1	0
84 150 to 84 250	1	1	1	1	1	1	1	1	1	1	0	0
84 250 to 84 350	1	1	1	1	1	1	1	1	0	1	0	0
84 350 to 84 450	1	1	1	1	1	1	1	1	0	1	1	0
84 450 to 84 550	1	1	1	1	1	1	1	1	0	0	1	0
84 550 to 84 650	1	1	1	1	1	1	1	1	0	0	1	1
84 650 to 84 750	1	1	1	1	1	1	1	1	0	0	0	1
84 750 to 84 850	1	1	1	1	1	0	1	0	0	0	0	1
84 850 to 84 950	1	1	1	1	1	0	1	0	0	0	1	1
84 950 to 85 050	1	1	1	1	1	0	1	0	0	0	1	0
85 050 to 85 150	1	1	1	1	1	0	1	0	0	1	1	0
85 150 to 85 250	1	1	1	1	1	0	1	0	0	1	0	0
85 250 to 85 350	1	1	1	1	1	0	1	1	0	1	0	0
85 350 to 85 450	1	1	1	1	1	0	1	1	0	1	1	0
85 450 to 85 550	1	1	1	1	1	0	1	1	0	0	1	0
85 550 to 85 650	1	1	1	1	1	0	1	1	0	0	1	1
85 650 to 85 750	1	1	1	1	1	0	1	1	0	0	0	1
85 750 to 85 850	1	1	1	1	1	0	0	1	0	0	0	1
85 850 to 85 950	1	1	1	1	1	0	0	1	0	0	1	1
85 950 to 86 050	1	1	1	1	1	0	0	1	0	0	1	0
86 050 to 86 150	1	1	1	1	1	0	0	1	1	1	1	0
86 150 to 86 250	1	1	1	1	1	0	0	1	1	0	0	0
86 250 to 86 350	1	1	1	1	1	0	0	0	1	0	0	0
86 350 to 86 450	1	1	1	1	1	0	0	0	1	1	1	0
86 450 to 86 550	1	1	1	1	1	0	0	0	0	0	1	0
86 550 to 86 650	1	1	1	1	1	0	0	0	0	0	1	1
86 650 to 86 750	1	1	1	1	1	0	0	0	0	0	0	1
86 750 to 86 850	1	1	1	0	1	0	0	0	0	0	0	1
86 850 to 86 950	1	1	1	0	1	0	0	0	0	0	1	1
86 950 to 87 050	1	1	1	0	1	0	0	0	0	0	1	0
87 050 to 87 150	1	1	1	0	1	0	0	0	1	1	1	0
87 150 to 87 250	1	1	1	0	1	0	0	0	1	0	0	0
87 250 to 87 350	1	1	1	0	1	0	0	1	1	0	0	0
87 350 to 87 450	1	1	1	0	1	0	0	1	1	1	1	0
87 450 to 87 550	1	1	1	0	1	0	0	1	0	0	1	0
87 550 to 87 650	1	1	1	0	1	0	0	1	0	0	1	1
87 650 to 87 750	1	1	1	0	1	0	0	1	0	0	0	1
87 750 to 87 850	1	1	1	0	1	0	1	1	0	0	0	1
87 850 to 87 950	1	1	1	0	1	0	1	1	0	0	1	1
87 950 to 88 050	1	1	1	0	1	0	1	1	0	0	1	0
88 050 to 88 150	1	1	1	0	1	0	1	1	1	1	1	0
88 150 to 88 250	1	1	1	0	1	0	1	1	1	0	0	0



RANGE	PULSE POSITIONS (0 or 1 in a pulse position denotes absence or presence of a pulse, respectively)											
	Increments (Feet)	D <sub>2</sub>	D <sub>4</sub>	A <sub>1</sub>	A <sub>2</sub>	A <sub>4</sub>	B <sub>1</sub>	B <sub>2</sub>	B <sub>4</sub>	C <sub>1</sub>	C <sub>2</sub>	C <sub>4</sub>
88 250 to 88 350	1	1	1	0	1	0	1	0	1	0	0	0
88 350 to 88 450	1	1	1	0	1	0	1	0	1	0	1	0
88 450 to 88 550	1	1	1	0	1	0	1	0	1	0	0	0
88 550 to 88 650	1	1	1	0	1	0	1	0	1	0	1	1
88 650 to 88 750	1	1	1	0	1	0	1	0	1	0	0	1
88 750 to 88 850	1	1	1	0	1	1	1	1	0	0	0	1
88 850 to 88 950	1	1	1	0	1	1	1	1	0	0	1	1
88 950 to 89 050	1	1	1	0	1	1	1	1	0	0	1	0
89 050 to 89 150	1	1	1	0	1	1	1	1	0	1	1	0
89 150 to 89 250	1	1	1	0	1	1	1	1	0	1	0	0
89 250 to 89 350	1	1	1	0	1	1	1	1	1	1	0	0
89 350 to 89 450	1	1	1	0	1	1	1	1	1	1	1	0
89 450 to 89 550	1	1	1	0	1	1	1	1	1	0	1	0
89 550 to 89 650	1	1	1	0	1	1	1	1	1	0	1	1
89 650 to 89 750	1	1	1	0	1	1	1	1	1	0	0	1
89 750 to 89 850	1	1	1	0	1	1	0	1	0	0	0	1
89 850 to 89 950	1	1	1	0	1	1	0	1	0	0	1	1
89 950 to 90 050	1	1	1	0	1	1	0	1	0	0	1	0
90 050 to 90 150	1	1	1	0	1	1	0	1	0	1	1	0
90 150 to 90 250	1	1	1	0	1	1	0	1	0	1	0	0
90 250 to 90 350	1	1	1	0	1	1	0	0	0	1	0	0
90 350 to 90 450	1	1	1	0	1	1	0	0	0	1	1	0
90 450 to 90 550	1	1	1	0	1	1	0	0	0	0	1	0
90 550 to 90 650	1	1	1	0	1	1	0	0	0	0	1	1
90 650 to 90 750	1	1	1	0	1	1	0	0	0	0	0	1
90 750 to 90 850	1	1	1	0	0	1	0	0	0	0	0	1
90 850 to 90 950	1	1	1	0	0	1	0	0	0	0	1	1
90 950 to 91 050	1	1	1	0	0	1	0	0	0	0	1	0
91 050 to 91 150	1	1	1	0	0	1	0	0	0	1	1	0
91 150 to 91 250	1	1	1	0	0	1	0	0	0	1	0	0
91 250 to 91 350	1	1	1	0	0	1	0	1	1	1	0	0
91 350 to 91 450	1	1	1	0	0	1	0	1	1	1	1	0
91 450 to 91 550	1	1	1	0	0	1	0	1	0	0	1	0
91 550 to 91 650	1	1	1	0	0	1	0	1	0	0	1	1
91 650 to 91 750	1	1	1	0	0	1	0	1	0	0	0	1
91 750 to 91 850	1	1	1	0	0	1	1	1	1	0	0	1
91 850 to 91 950	1	1	1	0	0	1	1	1	1	0	1	1
91 950 to 92 050	1	1	1	0	0	1	1	1	1	0	1	0
92 050 to 92 150	1	1	1	0	0	1	1	1	1	1	1	0
92 150 to 92 250	1	1	1	0	0	1	1	1	1	1	0	0
92 250 to 92 350	1	1	1	0	0	1	1	0	0	1	0	0
92 350 to 92 450	1	1	1	0	0	1	1	0	0	1	1	0
92 450 to 92 550	1	1	1	0	0	1	1	0	0	0	1	0
92 550 to 92 650	1	1	1	0	0	1	1	0	0	0	1	1
92 650 to 92 750	1	1	1	0	0	1	1	0	0	0	0	1

RANGE	PULSE POSITIONS (0 or 1 in a pulse position denotes absence or presence of a pulse, respectively)											
	Increments (Feet)	D <sub>2</sub>	D <sub>4</sub>	A <sub>1</sub>	A <sub>2</sub>	A <sub>4</sub>	B <sub>1</sub>	B <sub>2</sub>	B <sub>4</sub>	C <sub>1</sub>	C <sub>2</sub>	C <sub>4</sub>
92 750 to 92 850	1	1	1	0	0	0	0	1	0	0	0	1
92 850 to 92 950	1	1	1	0	0	0	0	1	0	0	1	1
92 950 to 93 050	1	1	1	0	0	0	0	1	0	0	1	0
93 050 to 93 150	1	1	1	0	0	0	0	1	0	1	1	0
93 150 to 93 250	1	1	1	0	0	0	0	1	0	1	0	0
93 250 to 93 350	1	1	1	0	0	0	0	1	1	1	0	0
93 350 to 93 450	1	1	1	0	0	0	0	1	1	1	1	0
93 450 to 93 550	1	1	1	0	0	0	0	1	1	0	1	0
93 550 to 93 650	1	1	1	0	0	0	0	1	1	0	1	1
93 650 to 93 750	1	1	1	0	0	0	0	1	1	0	0	1
93 750 to 93 850	1	1	1	0	0	0	0	0	1	0	0	1
93 850 to 93 950	1	1	1	0	0	0	0	0	1	0	1	1
93 950 to 94 050	1	1	1	0	0	0	0	0	1	0	1	0
94 050 to 94 150	1	1	1	0	0	0	0	0	1	1	1	0
94 150 to 94 250	1	1	1	0	0	0	0	0	1	1	0	0
94 250 to 94 350	1	1	1	0	0	0	0	0	0	1	0	0
94 350 to 94 450	1	1	1	0	0	0	0	0	0	1	1	0
94 450 to 94 550	1	1	1	0	0	0	0	0	0	0	1	0
94 550 to 94 650	1	1	1	0	0	0	0	0	0	0	1	1
94 650 to 94 750	1	1	1	0	0	0	0	0	0	0	0	1
94 750 to 94 850	1	0	1	0	0	0	0	0	0	0	0	1
94 850 to 94 950	1	0	1	0	0	0	0	0	0	0	1	1
94 950 to 95 050	1	0	1	0	0	0	0	0	0	0	1	0
95 050 to 95 150	1	0	1	0	0	0	0	0	0	1	1	0
95 150 to 95 250	1	0	1	0	0	0	0	0	0	1	0	0
95 250 to 95 350	1	0	1	0	0	0	0	0	1	1	0	0
95 350 to 95 450	1	0	1	0	0	0	0	0	1	1	1	0
95 450 to 95 550	1	0	1	0	0	0	0	0	1	0	1	0
95 550 to 95 650	1	0	1	0	0	0	0	0	1	0	1	1
95 650 to 95 750	1	0	1	0	0	0	0	0	1	0	0	1
95 750 to 95 850	1	0	1	0	0	0	0	1	1	0	0	1
95 850 to 95 950	1	0	1	0	0	0	0	1	1	0	1	1
95 950 to 96 050	1	0	1	0	0	0	0	1	1	0	1	0
96 050 to 96 150	1	0	1	0	0	0	0	1	1	1	1	0
96 150 to 96 250	1	0	1	0	0	0	0	1	1	1	0	0
96 250 to 96 350	1	0	1	0	0	0	0	1	0	1	0	0
96 350 to 96 450	1	0	1	0	0	0	0	1	0	1	1	0
96 450 to 96 550	1	0	1	0	0	0	0	1	0	0	1	0
96 550 to 96 650	1	0	1	0	0	0	0	1	0	0	1	1
96 650 to 96 750	1	0	1	0	0	0	0	1	0	0	0	1
96 750 to 96 850	1	0	1	0	0	0	1	1	0	0	0	1
96 850 to 96 950	1	0	1	0	0	0	1	1	0	0	1	1
96 950 to 97 050	1	0	1	0	0	0	1	1	0	0	1	0
97 050 to 97 150	1	0	1	0	0	0	1	1	0	1	1	0
97 150 to 97 250	1	0	1	0	0	0	1	1	0	1	0	0

RANGE	PULSE POSITIONS (0 or 1 in a pulse position denotes absence or presence of a pulse, respectively)											
	Increments (Feet)	D <sub>2</sub>	D <sub>4</sub>	A <sub>1</sub>	A <sub>2</sub>	A <sub>4</sub>	B <sub>1</sub>	B <sub>2</sub>	B <sub>4</sub>	C <sub>1</sub>	C <sub>2</sub>	C <sub>4</sub>
97 250 to 97 350	1	0	1	0	0	1	1	1	1	0	0	0
97 350 to 97 450	1	0	1	0	0	1	1	1	1	1	1	0
97 450 to 97 550	1	0	1	0	0	1	1	1	1	0	1	0
97 550 to 97 650	1	0	1	0	0	1	1	1	1	0	1	1
97 650 to 97 750	1	0	1	0	0	1	1	1	1	0	0	1
97 750 to 97 850	1	0	1	0	0	1	0	1	1	0	0	1
97 850 to 97 950	1	0	1	0	0	1	0	1	1	0	1	1
97 950 to 98 050	1	0	1	0	0	1	0	1	1	0	1	0
98 050 to 98 150	1	0	1	0	0	1	0	1	1	1	1	0
98 150 to 98 250	1	0	1	0	0	1	0	1	1	1	0	0
98 250 to 98 350	1	0	1	0	0	1	0	0	1	0	0	0
98 350 to 98 450	1	0	1	0	0	1	0	0	1	1	1	0
98 450 to 98 550	1	0	1	0	0	1	0	0	0	0	1	0
98 550 to 98 650	1	0	1	0	0	1	0	0	0	0	1	1
98 650 to 98 750	1	0	1	0	0	1	0	0	0	0	0	1
98 750 to 98 850	1	0	1	0	1	1	0	0	0	0	0	1
98 850 to 98 950	1	0	1	0	1	1	0	0	0	0	1	1
98 950 to 99 050	1	0	1	0	1	1	0	0	0	0	1	0
99 050 to 99 150	1	0	1	0	1	1	0	0	0	1	1	0
99 150 to 99 250	1	0	1	0	1	1	0	0	0	1	0	0
99 250 to 99 350	1	0	1	0	1	1	0	1	1	0	0	0
99 350 to 99 450	1	0	1	0	1	1	0	1	1	1	1	0
99 450 to 99 550	1	0	1	0	1	1	0	1	0	0	1	0
99 550 to 99 650	1	0	1	0	1	1	0	1	0	0	1	1
99 650 to 99 750	1	0	1	0	1	1	0	1	0	0	0	1
99 750 to 99 850	1	0	1	0	1	1	1	1	1	0	0	1
99 850 to 99 950	1	0	1	0	1	1	1	1	1	0	1	1
99 950 to 100 050	1	0	1	0	1	1	1	1	1	0	1	0
100 050 to 100 150	1	0	1	0	1	1	1	1	1	1	1	0
100 150 to 100 250	1	0	1	0	1	1	1	1	1	1	0	0
100 250 to 100 350	1	0	1	0	1	1	1	0	1	0	0	0
100 350 to 100 450	1	0	1	0	1	1	1	0	1	1	1	0
100 450 to 100 550	1	0	1	0	1	1	1	0	0	0	1	0
100 550 to 100 650	1	0	1	0	1	1	1	0	0	0	1	1
100 650 to 100 750	1	0	1	0	1	1	1	0	0	0	0	1
100 750 to 100 850	1	0	1	0	1	0	1	0	0	0	0	1
100 850 to 100 950	1	0	1	0	1	0	1	0	0	0	1	1
100 950 to 101 050	1	0	1	0	1	0	1	0	0	0	1	0
101 050 to 101 150	1	0	1	0	1	0	1	0	1	1	1	0
101 150 to 101 250	1	0	1	0	1	0	1	0	1	1	0	0
101 250 to 101 350	1	0	1	0	1	0	1	1	1	0	0	0
101 350 to 101 450	1	0	1	0	1	0	1	1	1	1	1	0
101 450 to 101 550	1	0	1	0	1	0	1	1	0	0	1	0
101 550 to 101 650	1	0	1	0	1	0	1	1	0	0	1	1
101 650 to 101 750	1	0	1	0	1	0	1	1	0	0	0	1

RANGE	PULSE POSITIONS (0 or 1 in a pulse position denotes absence or presence of a pulse, respectively)										
	Increments (Feet)	D <sub>2</sub>	D <sub>4</sub>	A <sub>1</sub>	A <sub>2</sub>	A <sub>4</sub>	B <sub>1</sub>	B <sub>2</sub>	B <sub>4</sub>	C <sub>1</sub>	C <sub>2</sub>
101 750 to 101 850	1	0	1	0	1	0	0	1	0	0	1
101 850 to 101 950	1	0	1	0	1	0	0	1	0	1	1
101 950 to 102 050	1	0	1	0	1	0	0	1	0	1	0
102 050 to 102 150	1	0	1	0	1	0	0	1	1	1	0
102 150 to 102 250	1	0	1	0	1	0	0	1	1	0	0
102 250 to 102 350	1	0	1	0	1	0	0	0	1	0	0
102 350 to 102 450	1	0	1	0	1	0	0	0	1	1	0
102 450 to 102 550	1	0	1	0	1	0	0	0	0	1	0
102 550 to 102 650	1	0	1	0	1	0	0	0	0	1	1
102 650 to 102 750	1	0	1	0	1	0	0	0	0	0	1
102 750 to 102 850	1	0	1	1	1	0	0	0	0	0	1
102 850 to 102 950	1	0	1	1	1	0	0	0	0	1	1
102 950 to 103 050	1	0	1	1	1	0	0	0	0	1	0
103 050 to 103 150	1	0	1	1	1	0	0	0	1	1	0
103 150 to 103 250	1	0	1	1	1	0	0	0	1	0	0
103 250 to 103 350	1	0	1	1	1	0	0	1	1	0	0
103 350 to 103 450	1	0	1	1	1	0	0	1	1	1	0
103 450 to 103 550	1	0	1	1	1	0	0	1	0	1	0
103 550 to 103 650	1	0	1	1	1	0	0	1	0	1	1
103 650 to 103 750	1	0	1	1	1	0	0	1	0	0	1
103 750 to 103 850	1	0	1	1	1	0	1	1	0	0	1
103 850 to 103 950	1	0	1	1	1	0	1	1	0	1	1
103 950 to 104 050	1	0	1	1	1	0	1	1	0	1	0
104 050 to 104 150	1	0	1	1	1	0	1	1	1	1	0
104 150 to 104 250	1	0	1	1	1	0	1	1	1	0	0
104 250 to 104 350	1	0	1	1	1	0	1	0	1	0	0
104 350 to 104 450	1	0	1	1	1	0	1	0	1	1	0
104 450 to 104 550	1	0	1	1	1	0	1	0	0	1	0
104 550 to 104 650	1	0	1	1	1	0	1	0	0	1	1
104 650 to 104 750	1	0	1	1	1	0	1	0	0	0	1
104 750 to 104 850	1	0	1	1	1	1	1	0	0	0	1
104 850 to 104 950	1	0	1	1	1	1	1	0	0	1	1
104 950 to 105 050	1	0	1	1	1	1	1	0	0	1	0
105 050 to 105 150	1	0	1	1	1	1	1	0	1	1	0
105 150 to 105 250	1	0	1	1	1	1	1	0	1	0	0
105 250 to 105 350	1	0	1	1	1	1	1	1	1	0	0
105 350 to 105 450	1	0	1	1	1	1	1	1	1	1	0
105 450 to 105 550	1	0	1	1	1	1	1	1	0	1	0
105 550 to 105 650	1	0	1	1	1	1	1	1	0	1	1
105 650 to 105 750	1	0	1	1	1	1	1	1	0	0	1
105 750 to 105 850	1	0	1	1	1	1	0	1	0	0	1
105 850 to 105 950	1	0	1	1	1	1	0	1	0	1	1
105 950 to 106 050	1	0	1	1	1	1	0	1	0	1	0
106 050 to 106 150	1	0	1	1	1	1	0	1	1	1	0
106 150 to 106 250	1	0	1	1	1	1	0	1	1	0	0

RANGE	PULSE POSITIONS (0 or 1 in a pulse position denotes absence or presence of a pulse, respectively)											
	Increments (Feet)	D <sub>2</sub>	D <sub>4</sub>	A <sub>1</sub>	A <sub>2</sub>	A <sub>4</sub>	B <sub>1</sub>	B <sub>2</sub>	B <sub>4</sub>	C <sub>1</sub>	C <sub>2</sub>	C <sub>4</sub>
106 250 to 106 350	1	0	1	1	1	1	1	0	0	1	0	0
106 350 to 106 450	1	0	1	1	1	1	1	0	0	1	1	0
106 450 to 106 550	1	0	1	1	1	1	1	0	0	0	1	0
106 550 to 106 650	1	0	1	1	1	1	1	0	0	0	1	1
106 650 to 106 750	1	0	1	1	1	1	1	0	0	0	0	1
106 750 to 106 850	1	0	1	1	0	1	0	0	0	0	0	1
106 850 to 106 950	1	0	1	1	0	1	0	0	0	0	1	1
106 950 to 107 050	1	0	1	1	0	1	0	0	0	0	1	0
107 050 to 107 150	1	0	1	1	0	1	0	0	0	1	1	0
107 150 to 107 250	1	0	1	1	0	1	0	0	0	1	0	0
107 250 to 107 350	1	0	1	1	0	1	0	1	0	1	0	0
107 350 to 107 450	1	0	1	1	0	1	0	1	0	1	1	0
107 450 to 107 550	1	0	1	1	0	1	0	1	0	0	1	0
107 550 to 107 650	1	0	1	1	0	1	0	1	0	0	1	1
107 650 to 107 750	1	0	1	1	0	1	0	1	0	0	0	1
107 750 to 107 850	1	0	1	1	0	1	1	1	1	0	0	1
107 850 to 107 950	1	0	1	1	0	1	1	1	1	0	1	1
107 950 to 108 050	1	0	1	1	0	1	1	1	1	0	1	0
108 050 to 108 150	1	0	1	1	0	1	1	1	1	1	1	0
108 150 to 108 250	1	0	1	1	0	1	1	1	1	1	0	0
108 250 to 108 350	1	0	1	1	0	1	1	0	0	1	0	0
108 350 to 108 450	1	0	1	1	0	1	1	0	0	1	1	0
108 450 to 108 550	1	0	1	1	0	1	1	0	0	0	1	0
108 550 to 108 650	1	0	1	1	0	1	1	0	0	0	1	1
108 650 to 108 750	1	0	1	1	0	1	1	0	0	0	0	1
108 750 to 108 850	1	0	1	1	0	0	1	0	0	0	0	1
108 850 to 108 950	1	0	1	1	0	0	1	0	0	0	1	1
108 950 to 109 050	1	0	1	1	0	0	1	0	0	0	1	0
109 050 to 109 150	1	0	1	1	0	0	1	0	0	1	1	0
109 150 to 109 250	1	0	1	1	0	0	1	0	0	1	0	0
109 250 to 109 350	1	0	1	1	0	0	1	1	1	1	0	0
109 350 to 109 450	1	0	1	1	0	0	1	1	1	1	1	0
109 450 to 109 550	1	0	1	1	0	0	1	1	1	0	1	0
109 550 to 109 650	1	0	1	1	0	0	1	1	1	0	1	1
109 650 to 109 750	1	0	1	1	0	0	1	1	1	0	0	1
109 750 to 109 850	1	0	1	1	0	0	0	0	1	0	0	1
109 850 to 109 950	1	0	1	1	0	0	0	0	1	0	1	1
109 950 to 110 050	1	0	1	1	0	0	0	0	1	0	1	0
110 050 to 110 150	1	0	1	1	0	0	0	0	1	1	1	0
110 150 to 110 250	1	0	1	1	0	0	0	0	1	1	0	0
110 250 to 110 350	1	0	1	1	0	0	0	0	0	1	0	0
110 350 to 110 450	1	0	1	1	0	0	0	0	0	1	1	0
110 450 to 110 550	1	0	1	1	0	0	0	0	0	0	1	0
110 550 to 110 650	1	0	1	1	0	0	0	0	0	0	1	1
110 650 to 110 750	1	0	1	1	0	0	0	0	0	0	0	1

RANGE	PULSE POSITIONS (0 or 1 in a pulse position denotes absence or presence of a pulse, respectively)											
	Increments (Feet)	D <sub>2</sub>	D <sub>4</sub>	A <sub>1</sub>	A <sub>2</sub>	A <sub>4</sub>	B <sub>1</sub>	B <sub>2</sub>	B <sub>4</sub>	C <sub>1</sub>	C <sub>2</sub>	C <sub>4</sub>
110 750 to 110 850	1	0	0	1	0	0	0	0	0	0	0	1
110 850 to 110 950	1	0	0	1	0	0	0	0	0	0	1	1
110 950 to 111 050	1	0	0	1	0	0	0	0	0	0	1	0
111 050 to 111 150	1	0	0	1	0	0	0	0	0	1	1	0
111 150 to 111 250	1	0	0	1	0	0	0	0	0	1	0	0
111 250 to 111 350	1	0	0	1	0	0	0	0	1	1	0	0
111 350 to 111 450	1	0	0	1	0	0	0	0	1	1	1	0
111 450 to 111 550	1	0	0	1	0	0	0	0	1	0	1	0
111 550 to 111 650	1	0	0	1	0	0	0	0	1	0	1	1
111 650 to 111 750	1	0	0	1	0	0	0	0	1	0	0	1
111 750 to 111 850	1	0	0	1	0	0	1	1	1	0	0	1
111 850 to 111 950	1	0	0	1	0	0	1	1	1	0	1	1
111 950 to 112 050	1	0	0	1	0	0	1	1	1	0	1	0
112 050 to 112 150	1	0	0	1	0	0	1	1	1	1	1	0
112 150 to 112 250	1	0	0	1	0	0	1	1	1	1	0	0
112 250 to 112 350	1	0	0	1	0	0	1	0	1	1	0	0
112 350 to 112 450	1	0	0	1	0	0	1	0	1	1	1	0
112 450 to 112 550	1	0	0	1	0	0	1	0	1	0	1	0
112 550 to 112 650	1	0	0	1	0	0	1	0	1	0	1	1
112 650 to 112 750	1	0	0	1	0	0	1	0	1	0	0	1
112 750 to 112 850	1	0	0	1	0	1	1	1	0	0	0	1
112 850 to 112 950	1	0	0	1	0	1	1	1	0	0	1	1
112 950 to 113 050	1	0	0	1	0	1	1	1	0	0	1	0
113 050 to 113 150	1	0	0	1	0	1	1	1	0	1	1	0
113 150 to 113 250	1	0	0	1	0	1	1	1	0	1	0	0
113 250 to 113 350	1	0	0	1	0	1	1	1	1	1	0	0
113 350 to 113 450	1	0	0	1	0	1	1	1	1	1	1	0
113 450 to 113 550	1	0	0	1	0	1	1	1	1	0	1	0
113 550 to 113 650	1	0	0	1	0	1	1	1	1	0	1	1
113 650 to 113 750	1	0	0	1	0	1	1	1	1	0	0	1
113 750 to 113 850	1	0	0	1	0	1	0	1	1	0	0	1
113 850 to 113 950	1	0	0	1	0	1	0	1	1	0	1	1
113 950 to 114 050	1	0	0	1	0	1	0	1	1	0	1	0
114 050 to 114 150	1	0	0	1	0	1	0	1	1	1	1	0
114 150 to 114 250	1	0	0	1	0	1	0	1	1	1	0	0
114 250 to 114 350	1	0	0	1	0	1	0	0	1	0	0	0
114 350 to 114 450	1	0	0	1	0	1	0	0	1	1	1	0
114 450 to 114 550	1	0	0	1	0	1	0	0	0	1	1	0
114 550 to 114 650	1	0	0	1	0	1	0	0	0	1	1	1
114 650 to 114 750	1	0	0	1	0	1	0	0	0	0	0	1
114 750 to 114 850	1	0	0	1	1	1	0	0	0	0	0	1
114 850 to 114 950	1	0	0	1	1	1	0	0	0	0	1	1
114 950 to 115 050	1	0	0	1	1	1	0	0	0	0	1	0
115 050 to 115 150	1	0	0	1	1	1	0	0	0	1	1	0
115 150 to 115 250	1	0	0	1	1	1	0	0	0	1	0	0

RANGE	PULSE POSITIONS (0 or 1 in a pulse position denotes absence or presence of a pulse, respectively)										
	Increments (Feet)	D <sub>2</sub>	D <sub>4</sub>	A <sub>1</sub>	A <sub>2</sub>	A <sub>4</sub>	B <sub>1</sub>	B <sub>2</sub>	B <sub>4</sub>	C <sub>1</sub>	C <sub>2</sub>
115 250 to 115 350	1	0	0	1	1	1	0	1	1	0	0
115 350 to 115 450	1	0	0	1	1	1	0	1	1	1	0
115 450 to 115 550	1	0	0	1	1	1	0	1	0	1	0
115 550 to 115 650	1	0	0	1	1	1	0	1	0	1	1
115 650 to 115 750	1	0	0	1	1	1	0	1	0	0	1
115 750 to 115 850	1	0	0	1	1	1	1	1	0	0	1
115 850 to 115 950	1	0	0	1	1	1	1	1	0	1	1
115 950 to 116 050	1	0	0	1	1	1	1	1	0	1	0
116 050 to 116 150	1	0	0	1	1	1	1	1	1	1	0
116 150 to 116 250	1	0	0	1	1	1	1	1	1	0	0
116 250 to 116 350	1	0	0	1	1	1	1	0	1	0	0
116 350 to 116 450	1	0	0	1	1	1	1	0	1	1	0
116 450 to 116 550	1	0	0	1	1	1	1	0	0	1	0
116 550 to 116 650	1	0	0	1	1	1	1	0	0	1	1
116 650 to 116 750	1	0	0	1	1	1	1	0	0	0	1
116 750 to 116 850	1	0	0	1	1	0	1	0	0	0	1
116 850 to 116 950	1	0	0	1	1	0	1	0	0	1	1
116 950 to 117 050	1	0	0	1	1	0	1	0	0	1	0
117 050 to 117 150	1	0	0	1	1	0	1	0	1	1	0
117 150 to 117 250	1	0	0	1	1	0	1	0	1	0	0
117 250 to 117 350	1	0	0	1	1	0	1	1	1	0	0
117 350 to 117 450	1	0	0	1	1	0	1	1	1	1	0
117 450 to 117 550	1	0	0	1	1	0	1	1	0	1	0
117 550 to 117 650	1	0	0	1	1	0	1	1	0	1	1
117 650 to 117 750	1	0	0	1	1	0	1	1	0	0	1
117 750 to 117 850	1	0	0	1	1	0	0	1	0	0	1
117 850 to 117 950	1	0	0	1	1	0	0	1	0	1	1
117 950 to 118 050	1	0	0	1	1	0	0	1	0	1	0
118 050 to 118 150	1	0	0	1	1	0	0	1	1	1	0
118 150 to 118 250	1	0	0	1	1	0	0	1	1	0	0
118 250 to 118 350	1	0	0	1	1	0	0	0	1	0	0
118 350 to 118 450	1	0	0	1	1	0	0	0	1	1	0
118 450 to 118 550	1	0	0	1	1	0	0	0	0	1	0
118 550 to 118 650	1	0	0	1	1	0	0	0	0	1	1
118 650 to 118 750	1	0	0	1	1	0	0	0	0	0	1
118 750 to 118 850	1	0	0	0	1	0	0	0	0	0	1
118 850 to 118 950	1	0	0	0	1	0	0	0	0	1	1
118 950 to 119 050	1	0	0	0	1	0	0	0	0	1	0
119 050 to 119 150	1	0	0	0	1	0	0	0	1	1	0
119 150 to 119 250	1	0	0	0	1	0	0	0	1	0	0
119 250 to 119 350	1	0	0	0	1	0	0	1	1	0	0
119 350 to 119 450	1	0	0	0	1	0	0	1	1	1	0
119 450 to 119 550	1	0	0	0	1	0	0	1	0	1	0
119 550 to 119 650	1	0	0	0	1	0	0	1	0	1	1
119 650 to 119 750	1	0	0	0	1	0	0	1	0	0	1

RANGE	PULSE POSITIONS (0 or 1 in a pulse position denotes absence or presence of a pulse, respectively)										
	Increments (Feet)	D <sub>2</sub>	D <sub>4</sub>	A <sub>1</sub>	A <sub>2</sub>	A <sub>4</sub>	B <sub>1</sub>	B <sub>2</sub>	B <sub>4</sub>	C <sub>1</sub>	C <sub>2</sub>
119 750 to 119 850	1	0	0	0	1	0	1	1	0	0	1
119 850 to 119 950	1	0	0	0	1	0	1	1	0	1	1
119 950 to 120 050	1	0	0	0	1	0	1	1	0	1	0
120 050 to 120 150	1	0	0	0	1	0	1	1	1	1	0
120 150 to 120 250	1	0	0	0	1	0	1	1	1	0	0
120 250 to 120 350	1	0	0	0	1	0	1	0	1	0	0
120 350 to 120 450	1	0	0	0	1	0	1	0	1	1	0
120 450 to 120 550	1	0	0	0	1	0	1	0	0	1	0
120 550 to 120 650	1	0	0	0	1	0	1	0	0	1	1
120 650 to 120 750	1	0	0	0	1	0	1	0	0	0	1
120 750 to 120 850	1	0	0	0	1	1	1	0	0	0	1
120 850 to 120 950	1	0	0	0	1	1	1	0	0	1	1
120 950 to 121 050	1	0	0	0	1	1	1	0	0	1	0
121 050 to 121 150	1	0	0	0	1	1	1	0	1	1	0
121 150 to 121 250	1	0	0	0	1	1	1	0	1	0	0
121 250 to 121 350	1	0	0	0	1	1	1	1	1	0	0
121 350 to 121 450	1	0	0	0	1	1	1	1	1	1	0
121 450 to 121 550	1	0	0	0	1	1	1	1	0	1	0
121 550 to 121 650	1	0	0	0	1	1	1	1	0	1	1
121 650 to 121 750	1	0	0	0	1	1	1	1	0	0	1
121 750 to 121 850	1	0	0	0	1	1	0	1	0	0	1
121 850 to 121 950	1	0	0	0	1	1	0	1	0	1	1
121 950 to 122 050	1	0	0	0	1	1	0	1	0	1	0
122 050 to 122 150	1	0	0	0	1	1	0	1	1	1	0
122 150 to 122 250	1	0	0	0	1	1	0	1	1	0	0
122 250 to 122 350	1	0	0	0	1	1	0	0	1	0	0
122 350 to 122 450	1	0	0	0	1	1	0	0	1	1	0
122 450 to 122 550	1	0	0	0	1	1	0	0	0	1	0
122 550 to 122 650	1	0	0	0	1	1	0	0	0	1	1
122 650 to 122 750	1	0	0	0	1	1	0	0	0	0	1
122 750 to 122 850	1	0	0	0	0	1	0	0	0	0	1
122 850 to 122 950	1	0	0	0	0	1	0	0	0	1	1
122 950 to 123 050	1	0	0	0	0	1	0	0	0	1	0
123 050 to 123 150	1	0	0	0	0	1	0	0	1	1	0
123 150 to 123 250	1	0	0	0	0	1	0	0	1	0	0
123 250 to 123 350	1	0	0	0	0	1	0	1	1	0	0
123 350 to 123 450	1	0	0	0	0	1	0	1	1	1	0
123 450 to 123 550	1	0	0	0	0	1	0	1	0	1	0
123 550 to 123 650	1	0	0	0	0	1	0	1	0	1	1
123 650 to 123 750	1	0	0	0	0	1	0	1	0	0	1
123 750 to 123 850	1	0	0	0	0	1	1	1	0	0	1
123 850 to 123 950	1	0	0	0	0	1	1	1	0	1	1
123 950 to 124 050	1	0	0	0	0	1	1	1	0	1	0
124 050 to 124 150	1	0	0	0	0	1	1	1	1	1	0
124 150 to 124 250	1	0	0	0	0	1	1	1	1	0	0



RANGE	PULSE POSITIONS <i>(0 or 1 in a pulse position denotes absence or presence of a pulse, respectively)</i>											
	Increments <i>(Feet)</i>	D <sub>2</sub>	D <sub>4</sub>	A <sub>1</sub>	A <sub>2</sub>	A <sub>4</sub>	B <sub>1</sub>	B <sub>2</sub>	B <sub>4</sub>	C <sub>1</sub>	C <sub>2</sub>	C <sub>4</sub>
124 250 to 124 350	1	0	0	0	0	0	1	1	0	1	0	0
124 350 to 124 450	1	0	0	0	0	0	1	1	0	1	1	0
124 450 to 124 550	1	0	0	0	0	0	1	1	0	0	1	0
124 550 to 124 650	1	0	0	0	0	0	1	1	0	0	1	1
124 650 to 124 750	1	0	0	0	0	0	1	1	0	0	0	1
124 750 to 124 850	1	0	0	0	0	0	0	1	0	0	0	1
124 850 to 124 950	1	0	0	0	0	0	0	1	0	0	1	1
124 950 to 125 050	1	0	0	0	0	0	0	1	0	0	1	0
125 050 to 125 150	1	0	0	0	0	0	0	1	0	1	1	0
125 150 to 125 250	1	0	0	0	0	0	0	1	0	1	0	0
125 250 to 125 350	1	0	0	0	0	0	0	1	1	1	0	0
125 350 to 125 450	1	0	0	0	0	0	0	1	1	1	1	0
125 450 to 125 550	1	0	0	0	0	0	0	1	1	0	1	0
125 550 to 125 650	1	0	0	0	0	0	0	1	1	0	1	1
125 650 to 125 750	1	0	0	0	0	0	0	1	1	0	0	1
125 750 to 125 850	1	0	0	0	0	0	0	0	1	0	0	1
125 850 to 125 950	1	0	0	0	0	0	0	0	1	0	1	1
125 950 to 126 050	1	0	0	0	0	0	0	0	1	0	1	0
126 050 to 126 150	1	0	0	0	0	0	0	0	1	1	1	0
126 150 to 126 250	1	0	0	0	0	0	0	0	1	1	0	0
126 250 to 126 350	1	0	0	0	0	0	0	0	0	1	0	0
126 350 to 126 450	1	0	0	0	0	0	0	0	0	1	1	0
126 450 to 126 550	1	0	0	0	0	0	0	0	0	0	1	0
126 550 to 126 650	1	0	0	0	0	0	0	0	0	0	1	1
126 650 to 126 750	1	0	0	0	0	0	0	0	0	0	0	1



## CHAPTER 4. AIRBORNE COLLISION AVOIDANCE SYSTEM

*Note 1.— Guidance material relating to the airborne collision avoidance system is contained in the Airborne Collision Avoidance System (ACAS) Manual (Doc 9863).*

*Note 2.— Non-SI alternative units are used as permitted by Annex 5, Chapter 3, 3.2.2. In limited cases, to ensure consistency at the level of the logic calculations, units such as ft/s, NM/s and kt/s are used.*

*Note 3.— The system that is compliant with Chapter 4 in its entirety is the one that incorporates the traffic alert and collision avoidance systems (TCAS) Version 7.1 and therefore meets the RTCA/DO-185B or EUROCAE/ED-143 specification.*

*Note 4.— Equipment complying with RTCA/DO-185A standards (also known as TCAS Version 7.0) is not compliant with Chapter 4 in its entirety.*

### 4.1 DEFINITIONS RELATING TO AIRBORNE COLLISION AVOIDANCE SYSTEM

**ACAS I.** An ACAS which provides information as an aid to “see and avoid” action but does not include the capability for generating resolution advisories (RAs).

*Note.— ACAS I is not intended for international implementation and standardization by ICAO. Therefore, only ACAS I characteristics required to ensure compatible operation with other ACAS configurations and interference limiting are defined in 4.2.*

**ACAS II.** An ACAS which provides vertical resolution advisories (RAs) in addition to traffic advisories (TAs).

**ACAS III.** An ACAS which provides vertical and horizontal resolution advisories (RAs) in addition to traffic advisories (TAs).

**ACAS broadcast.** A long Mode S air-air surveillance interrogation (UF = 16) with the broadcast address.

**Active RAC.** An RAC is active if it currently constrains the selection of the RA. RACs that have been received within the last six seconds and have not been explicitly cancelled are active.

**Altitude crossing RA.** A resolution advisory is altitude crossing if own ACAS aircraft is currently at least 30 m (100 ft) below or above the threat aircraft for upward or downward sense advisories, respectively.

**Climb RA.** A positive RA recommending a climb but not an increased climb.

**Closest approach.** The occurrence of minimum range between own ACAS aircraft and the intruder. Thus range at closest approach is the smallest range between the two aircraft and time of closest approach is the time at which this occurs.

**Coordination.** The process by which two ACAS-equipped aircraft select compatible resolution advisories (RAs) by the exchange of resolution advisory complements (RACs).

**Coordination interrogation.** A Mode S interrogation (uplink transmission) radiated by ACAS II or III and containing a resolution message.

**Coordination reply.** A Mode S reply (downlink transmission) acknowledging the receipt of a coordination interrogation by the Mode S transponder that is part of an ACAS II or III installation.

**Corrective RA.** A resolution advisory that advises the pilot to deviate from the current flight path.

**Cycle.** The term “cycle” used in this chapter refers to one complete pass through the sequence of functions executed by ACAS II or ACAS III, nominally once a second.

**Descend RA.** A positive RA recommending a descent but not an increased descent.

**Established track.** A track generated by ACAS air-air surveillance that is treated as the track of an actual aircraft.

**Increased rate RA.** A resolution advisory with a strength that recommends increasing the altitude rate to a value exceeding that recommended by a previous climb or descend RA.

**Intruder.** An SSR transponder-equipped aircraft within the surveillance range of ACAS for which ACAS has an established track.

**Own aircraft.** The aircraft fitted with the ACAS that is the subject of the discourse, which ACAS is to protect against possible collisions, and which may enter a manoeuvre in response to an ACAS indication.

**Positive RA.** A resolution advisory that advises the pilot either to climb or to descend (applies to ACAS II).

**Potential threat.** An intruder deserving special attention either because of its close proximity to own aircraft or because successive range and altitude measurements indicate that it could be on a collision or near-collision course with own aircraft. The warning time provided against a potential threat is sufficiently small that a traffic advisory (TA) is justified but not so small that a resolution advisory (RA) would be justified.

**Preventive RA.** A resolution advisory that advises the pilot to avoid certain deviations from the current flight path but does not require any change in the current flight path.

**RA sense.** The sense of an ACAS II RA is “upward” if it requires climb or limitation of descent rate and “downward” if it requires descent or limitation of climb rate. It can be both upward and downward simultaneously if it requires limitation of the vertical rate to a specified range.

*Note.— The RA sense may be both upward and downward when, having several simultaneous threats, ACAS generates an RA aimed at ensuring adequate separation below some threat(s) and above some other threat(s).*

**Resolution advisory (RA).** An indication given to the flight crew recommending:

- a) a manoeuvre intended to provide separation from all threats; or
- b) a manoeuvre restriction intended to maintain existing separation.

**Resolution advisory complement (RAC).** Information provided by one ACAS to another via a Mode S interrogation in order to ensure complementary manoeuvres by restricting the choice of manoeuvres available to the ACAS receiving the RAC.

**Resolution advisory complements record (RAC record).** A composite of all currently active vertical RACs (VRCs) and horizontal RACs (HRCs) that have been received by ACAS. This information is provided by one ACAS to another ACAS or to a Mode S ground station via a Mode S reply.

**Resolution advisory strength.** The magnitude of the manoeuvre indicated by the RA. An RA may take on several successive strengths before being cancelled. Once a new RA strength is issued, the previous one automatically becomes void.

**Resolution message.** The message containing the resolution advisory complement (RAC).

**Reversed sense RA.** A resolution advisory that has had its sense reversed.

**Sensitivity level (S).** An integer defining a set of parameters used by the traffic advisory (TA) and collision avoidance algorithms to control the warning time provided by the potential threat and threat detection logic, as well as the values of parameters relevant to the RA selection logic.

**Threat.** An intruder deserving special attention either because of its close proximity to own aircraft or because successive range and altitude measurements indicate that it could be on a collision or near-collision course with own aircraft. The warning time provided against a threat is sufficiently small that an RA is justified.

**Track.** A sequence of at least three measurements representing positions that could reasonably have been occupied by an aircraft.

**Traffic advisory (TA).** An indication given to the flight crew that a certain intruder is a potential threat.

**Vertical speed limit (VSL) RA.** A resolution advisory advising the pilot to avoid a given range of altitude rates. A VSL RA can be either corrective or preventive.

**Warning time.** The time interval between potential threat or threat detection and closest approach when neither aircraft accelerates.

## 4.2 ACAS I GENERAL PROVISIONS AND CHARACTERISTICS

4.2.1 *Functional requirements.* ACAS I shall perform the following functions:

- a) surveillance of nearby SSR transponder-equipped aircraft; and
- b) provide indications to the flight crew identifying the approximate position of nearby aircraft as an aid to visual acquisition.

*Note.*— ACAS I is intended to operate using Mode A/C interrogations only. Furthermore, it does not coordinate with other ACAS. Therefore, a Mode S transponder is not required as a part of an ACAS I installation.

4.2.2 *Signal format.* The RF characteristics of all ACAS I signals shall conform to the provisions of Chapter 3, 3.1.1.1 through 3.1.1.6 and 3.1.2.1 through 3.1.2.4.

### 4.2.3 Interference control

4.2.3.1 *Maximum radiated RF power.* The effective radiated power of an ACAS I transmission at 0 degree elevation relative to the longitudinal axis of the aircraft shall not exceed 24 dBW.

4.2.3.2 *Unwanted radiated power.* When ACAS I is not transmitting an interrogation, the effective radiated power in any direction shall not exceed –70 dBm.

*Note.*— This requirement is to ensure that, when not transmitting an interrogation, ACAS I does not radiate RF energy that could interfere with, or reduce the sensitivity of, the SSR transponder or radio equipment in other nearby aircraft or ground facilities.

4.2.3.3 *Interference limiting.* Each ACAS I interrogator shall control its interrogation rate or power or both in all SSR modes to minimize interference effects (4.2.3.3.3 and 4.2.3.3.4).

*Note.*— These limits are a means of ensuring that all interference effects resulting from these interrogations, together with the interrogations from all other ACAS I, ACAS II and ACAS III interrogators in the vicinity are kept to a low level.

4.2.3.3.1 *Determination of own transponder reply rate.* ACAS I shall monitor the rate that own transponder replies to interrogations to ensure that the provisions in 4.2.3.3.3 are met.

4.2.3.3.2 *Determination of the number of ACAS II and ACAS III interrogators.* ACAS I shall count the number of ACAS II and ACAS III interrogators in the vicinity to ensure that the provisions in 4.2.3.3.3 or 4.2.3.3.4 are met. This count shall be obtained by monitoring ACAS broadcasts (UF = 16), (4.3.7.1.2.4) and shall be updated as the number of distinct ACAS aircraft addresses received within the previous 20-s period at a nominal frequency of at least 1 Hz.

4.2.3.3.3 *Mode A/C ACAS I interference limits.* The interrogator power shall not exceed the following limits:

$n_a$	Upper limit for $\left\{ \sum_{k=1}^{k_t} P_a(k) \right\}$	
	If $f_r \leq 240$	If $f_r > 240$
0	250	118
1	250	113
2	250	108
3	250	103
4	250	98
5	250	94
6	250	89
7	250	84
8	250	79
9	250	74
10	245	70
11	228	65
12	210	60
13	193	55
14	175	50
15	158	45
16	144	41
17	126	36
18	109	31
19	91	26
20	74	21
21	60	17
$\geq 22$	42	12

where:

$n_a$  = number of operating ACAS II and ACAS III equipped aircraft near own (based on ACAS broadcasts received with a transponder receiver threshold of  $-74$  dBm);

{ } = average value of the expression within the brackets over last 8 interrogation cycles;

$P_a(k)$  = peak power radiated from the antenna in all directions of the pulse having the largest amplitude in the group of pulses comprising a single interrogation during the  $k$ th Mode A/C interrogation in a 1 s interrogation cycle, W;

- $k$  = index number for Mode A/C interrogations,  $k = 1, 2, \dots, k_i$ ;
- $k_i$  = number of Mode A/C interrogations transmitted in a 1 s interrogation cycle;
- $f_r$  = Mode A/C reply rate of own transponder.

4.2.3.3.4 *Mode S ACAS I interference limits.* An ACAS I that uses Mode S interrogations shall not cause greater interference effects than an ACAS I using Mode A/C interrogations only.

### 4.3 GENERAL PROVISIONS RELATING TO ACAS II AND ACAS III

*Note 1.— The acronym ACAS is used in this section to indicate either ACAS II or ACAS III.*

*Note 2.— Carriage requirements for ACAS equipment are addressed in Annex 6.*

*Note 3.— The term “equipped threat” is used in this section to indicate a threat fitted with ACAS II or ACAS III.*

#### 4.3.1 Functional requirements

4.3.1.1 *ACAS functions.* ACAS shall perform the following functions:

- a) surveillance;
- b) generation of TAs;
- c) threat detection;
- d) generation of RAs;
- e) coordination; and
- f) communication with ground stations.

The equipment shall execute functions b) through e) on each cycle of operation.

*Note.— Certain features of these functions must be standardized to ensure that ACAS units cooperate satisfactorily with other ACAS units, with Mode S ground stations and with the ATC system. Each of the features that are standardized is discussed below. Certain other features are given herein as recommendations.*

4.3.1.1.1 The duration of a cycle shall not exceed 1.2 s.

#### 4.3.2 Surveillance performance requirements

4.3.2.1 *General surveillance requirements.* ACAS shall interrogate SSR Mode A/C and Mode S transponders in other aircraft and detect the transponder replies. ACAS shall measure the range and relative bearing of responding aircraft. Using these measurements and information conveyed by transponder replies, ACAS shall estimate the relative positions of each responding aircraft. ACAS shall include provisions for achieving such position determination in the presence of ground reflections, interference and variations in signal strength.

4.3.2.1.1 *Track establishment probability.* ACAS shall generate an established track, with at least a 0.90 probability that the track is established 30 s before closest approach, on aircraft equipped with transponders when all of the following conditions are satisfied:

- a) the elevation angles of these aircraft are within  $\pm 10$  degrees relative to the ACAS aircraft pitch plane;
- b) the magnitudes of these aircraft's rates of change of altitude are less than or equal to 51 m/s (10 000 ft/min);
- c) the transponders and antennas of these aircraft meet the Standards of Chapter 3, 3.1.1 and 3.1.2;
- d) the closing speeds and directions of these aircraft, the local density of SSR transponder-equipped aircraft and the number of other ACAS interrogators in the vicinity (as determined by monitoring ACAS broadcasts, 4.3.7.1.2.4) satisfy the conditions specified in Table 4-1; and
- e) the minimum slant range is equal to or greater than 300 m (1 000 ft).

**Table 4-1. ACAS design assumptions**

Conditions								Performance	
Quadrant						Maximum traffic density		Maximum number of other ACAS within 56 km (30 NM)	Probability of success
Forward		Side		Back					
Maximum closing speed						aircraft/ km <sup>2</sup>	aircraft/ NM <sup>2</sup>		
m/s	kt	m/s	kt	m/s	kt				
260	500	150	300	93	180	0.087	0.30	30	0.9
620	1 200	390	750	220	430	0.017	0.06	30	0.9

*Note.*— Table 4-1 shows the design assumption upon which the development of ACAS was based. Operational experience and simulation show that ACAS provides adequate surveillance for collision avoidance even when the maximum number of other ACAS within 56 km (30 NM) is somewhat higher than that shown in Table 4-1. Future ACAS designs will take account of current and expected ACAS densities.

4.3.2.1.1.1 ACAS shall continue to provide surveillance with no abrupt degradation in track establishment probability as any one of the condition bounds defined in 4.3.2.1.1 is exceeded.

4.3.2.1.1.2 ACAS shall not track Mode S aircraft that report that they are on the ground.

*Note.*— A Mode S aircraft may report that it is on the ground by coding in the capability (CA) field in a DF = 11 or DF = 17 transmission (Chapter 3, 3.1.2.5.2.2.1) or by coding in the vertical status (VS) field in a DF = 0 transmission (Chapter 3, 3.1.2.8.2.1). Alternatively, if the aircraft is under Mode S ground surveillance, ground status may be determined by monitoring the flight status (FS) field in downlink formats DF = 4, 5, 20 or 21 (Chapter 3, 3.1.2.6.5.1).

4.3.2.1.1.3 **Recommendation.**— ACAS should achieve the required tracking performance when the average SSR Mode A/C asynchronous reply rate from transponders in the vicinity of the ACAS aircraft is 240 replies per second and when the peak interrogation rate received by the individual transponders under surveillance is 500 per second.

*Note.*— The peak interrogation rate mentioned above includes interrogations from all sources.



4.3.2.1.2 *False track probability.* The probability that an established Mode A/C track does not correspond in range and altitude, if reported, to an actual aircraft shall be less than  $10^{-2}$ . For an established Mode S track this probability shall be less than  $10^{-6}$ . These limits shall not be exceeded in any traffic environment.

#### 4.3.2.1.3 RANGE AND BEARING ACCURACY

4.3.2.1.3.1 Range shall be measured with a resolution of 14.5 m (1/128 NM) or better.

4.3.2.1.3.2 **Recommendation.**— *The errors in the relative bearings of the estimated positions of intruders should not exceed 10 degrees rms.*

*Note.*— *This accuracy in the relative bearing of intruders is practicable and sufficient as an aid to the visual acquisition of potential threats. In addition, such relative bearing information has been found useful in threat detection, where it can indicate that an intruder is a threat. However, this accuracy is not sufficient as a basis for horizontal RAs, nor is it sufficient for reliable predictions of horizontal miss distance.*

#### 4.3.2.2 INTERFERENCE CONTROL

4.3.2.2.1 *Maximum radiated RF power.* The effective radiated power of an ACAS transmission at 0 degree elevation relative to the longitudinal axis of the aircraft shall not exceed 27 dBW.

4.3.2.2.1.1 *Unwanted radiated power.* When ACAS is not transmitting an interrogation, the effective radiated power in any direction shall not exceed  $-70$  dBm.

4.3.2.2.2 *Interference limiting.* Each ACAS interrogator operating below a pressure-altitude of 5 490 m (18 000 ft) shall control its interrogation rate or power or both so as to conform with specific inequalities (4.3.2.2.2.2).

4.3.2.2.2.1 *Determination of the number of other ACAS.* ACAS shall count the number of other ACAS II and III interrogators in the vicinity to ensure that the interference limits are met. This count shall be obtained by monitoring ACAS broadcasts (UF = 16), (4.3.7.1.2.4). Each ACAS shall monitor such broadcast interrogations to determine the number of other ACAS within detection range.

4.3.2.2.2.2 *ACAS interference limiting inequalities.* ACAS shall adjust its interrogation rate and interrogation power such that the following three inequalities remain true, except as provided in 4.3.2.2.2.2.1.

$$\left\{ \sum_{i=1}^{i_t} \left[ \frac{p(i)}{250} \right]^\alpha \right\} < \text{minimum} \left[ \frac{280}{1+n_a}, \frac{11}{\alpha^2} \right] \quad (1)$$

$$\left\{ \sum_{i=1}^{i_t} m(i) \right\} < 0.01 \quad (2)$$

$$\left\{ \frac{1}{B} \sum_{k=1}^{k_t} \frac{P_a(k)}{250} \right\} < \text{minimum} \left[ \frac{80}{1+n_a}, 3 \right] \quad (3)$$

The variables in these inequalities shall be defined as follows:

$i_t$  = number of interrogations (Mode A/C and Mode S) transmitted in a 1 s interrogation cycle. This shall include all Mode S interrogations used by the ACAS functions, including those in addition to UF = 0 and UF = 16 interrogations, except as provided in 4.3.2.2.2.2.1;

Note.—  $UF = 19$  interrogations are included in  $i$ , as specified in 3.1.2.8.9.4.

- $i$  = index number for Mode A/C and Mode S interrogations,  $i = 1, 2, \dots, i_i$ ;
- $\alpha$  = the minimum of  $\alpha_1$  calculated as  $1/4 [n_b/n_c]$  subject to the special conditions given below and  $\alpha_2$  calculated as  $\text{Log}_{10} [n_a/n_b] / \text{Log}_{10} 25$ , where  $n_b$  and  $n_c$  are defined as the number of operating ACAS II and ACAS III equipped aircraft (airborne or on the ground) within 11.2 km (6 NM) and 5.6 km (3 NM) respectively, of own ACAS (based on ACAS surveillance). ACAS aircraft operating on the ground or at or below a radio altitude of 610 m (2 000 ft) AGL shall include both airborne and on-ground ACAS II and ACAS III aircraft in the value for  $n_b$  and  $n_c$ . Otherwise, ACAS shall include only airborne ACAS II and ACAS III aircraft in the value for  $n_b$  and  $n_c$ . The values of  $\alpha$ ,  $\alpha_1$  and  $\alpha_2$  are further constrained to a minimum of 0.5 and a maximum of 1.0.

In addition;

IF  $[(n_b \leq 1) \text{ OR } (n_b \leq 4 \text{ AND } n_c \leq 2 \text{ AND } n_a > 25)]$  THEN  $\alpha_1 = 1.0$ ,

IF  $[(n_c > 2) \text{ AND } (n_b > 2 n_c) \text{ AND } (n_a < 40)]$  THEN  $\alpha_1 = 0.5$ ;

$p(i)$  = peak power radiated from the antenna in all directions of the pulse having the largest amplitude in the group of pulses comprising a single interrogation during the  $i$ th interrogation in a 1 s interrogation cycle, W;

$m(i)$  = duration of the mutual suppression interval for own transponder associated with the  $i$ th interrogation in a 1 s interrogation cycle, s;

$B$  = beam sharpening factor (ratio of 3 dB beam width to beamwidth resulting from interrogation side-lobe suppression). For ACAS interrogators that employ transmitter side-lobe suppression (SLS), the appropriate beamwidth shall be the extent in azimuth angle of the Mode A/C replies from one transponder as limited by SLS, averaged over the transponder population;

{ } see 4.2.3.3.3

$P_a(k)$      "  
 $k$            "  
 $k_t$          "  
 $n_a$          "

Note.— RA and ACAS broadcasts (4.3.6.2.1 and 4.3.7.1.2.4) are interrogations.

4.3.2.2.2.2.1 *Transmissions during RAs.* All air-to-air coordination interrogations shall be transmitted at full power and these interrogations shall be excluded from the summations of Mode S interrogations in the left-hand terms of inequalities (1) and (2) in 4.3.2.2.2.2 for the duration of the RA.

4.3.2.2.2.2.2 *Transmissions from ACAS units on the ground.* Whenever the ACAS aircraft indicates that it is on the ground, ACAS interrogations shall be limited by setting the number of other ACAS II and III aircraft ( $n_a$ ) count in the interference limiting inequalities to a value that is three times the value obtained based on ACAS broadcasts received with a transponder receiver threshold of  $-74$  dBm. Whenever Mode A/C interrogation power is reduced because of interference limiting, the Mode A/C interrogation power in the forward beam shall be reduced first until the forward sequence matches the right and left sequences. The forward, right and left interrogation powers shall then sequentially be reduced until they match the rear interrogation power. Further reduction of Mode A/C power shall be accomplished by sequentially reducing the forward, side and rear interrogation powers.

4.3.2.2.2.2.3 *Transmissions from ACAS units above 5 490 m (18 000 ft) altitude.* Each ACAS interrogator operating above a pressure-altitude of 5 490 m (18 000 ft) shall control its interrogation rate or power or both such that inequalities (1) and (3) in 4.3.2.2.2.2 remain true when  $n_a$  and  $\alpha$  are equal to 1, except as provided in 4.3.2.2.2.1.

### 4.3.3 Traffic advisories (TAs)

4.3.3.1 *TA function.* ACAS shall provide TAs to alert the flight crew to potential threats. Such TAs shall be accompanied by an indication of the approximate relative position of potential threats to facilitate visual acquisition.

4.3.3.1.1 *Display of potential threats.* If potential threats are shown on a traffic display, they shall be displayed in amber or yellow.

*Note 1.— These colours are generally considered suitable for indicating a cautionary condition.*

*Note 2.— Additional information assisting in the visual acquisition such as vertical trend and relative altitude may be displayed as well.*

*Note 3.— Traffic situational awareness is improved when tracks can be supplemented by display of heading information (e.g. as extracted from received ADS-B messages).*

#### 4.3.3.2 PROXIMATE TRAFFIC DISPLAY

4.3.3.2.1 **Recommendation.**— *While any RA and/or TA are displayed, proximate traffic within 11 km (6 NM) range and, if altitude reporting,  $\pm 370$  m (1 200 ft) altitude should be displayed. This proximate traffic should be distinguished (e.g. by colour or symbol type) from threats and potential threats, which should be more prominently displayed.*

4.3.3.2.2 **Recommendation.**— *While any RA and/or TA are displayed, visual acquisition of the threats and/or potential threat should not be adversely affected by the display of proximate traffic or other data (e.g. contents of received ADS-B messages) unrelated to collision avoidance.*

4.3.3.3 *TAs as RA precursors.* The criteria for TAs shall be such that they are satisfied before those for an RA.

4.3.3.3.1 *TA warning time.* For intruders reporting altitude, the nominal TA warning time shall not be greater than (T+20 s) where T is the nominal warning time for the generation of the resolution advisory.

*Note.— Ideally, RAs would always be preceded by a TA but this is not always possible, e.g. the RA criteria might be already satisfied when a track is first established, or a sudden and sharp manoeuvre by the intruder could cause the TA lead time to be less than a cycle.*

### 4.3.4 Threat detection

4.3.4.1 *Declaration of threat.* ACAS shall evaluate appropriate characteristics of each intruder to determine whether or not it is a threat.

4.3.4.1.1 *Intruder characteristics.* As a minimum, the characteristics of an intruder that are used to identify a threat shall include:

- a) tracked altitude;
- b) tracked rate of change of altitude;
- c) tracked slant range;

- d) tracked rate of change of slant range; and
- e) sensitivity level of intruder's ACAS,  $S_i$ .

For an intruder not equipped with ACAS II or ACAS III,  $S_i$  shall be set to 1.

4.3.4.1.2 *Own aircraft characteristics.* As a minimum, the characteristics of own aircraft that are used to identify a threat shall include:

- a) altitude;
- b) rate of change of altitude; and
- c) sensitivity level of own ACAS (4.3.4.3).

4.3.4.2 *Sensitivity levels.* ACAS shall be capable of operating at any of a number of sensitivity levels. These shall include:

- a)  $S = 1$ , a “standby” mode in which the interrogation of other aircraft and all advisories are inhibited;
- b)  $S = 2$ , a “TA only” mode in which RAs are inhibited; and
- c)  $S = 3-7$ , further levels that enable the issue of RAs that provide the warning times indicated in Table 4-2 as well as TAs.

4.3.4.3 *Selection of own sensitivity level ( $S_o$ ).* The selection of own ACAS sensitivity level shall be determined by sensitivity level control (SLC) commands which shall be accepted from a number of sources as follows:

- a) SLC command generated automatically by ACAS based on altitude band or other external factors;
- b) SLC command from pilot input; and
- c) SLC command from Mode S ground stations.

4.3.4.3.1 *Permitted SLC command codes.* As a minimum, the acceptable SLC command codes shall include:

	<i>Coding</i>
for SLC based on altitude band	2-7
for SLC from pilot input	0,1,2
for SLC from Mode S ground stations	0,2-6

4.3.4.3.2 *Altitude-band SLC command.* Where ACAS selects an SLC command based on altitude, hysteresis shall be applied to the nominal altitude thresholds at which SLC command value changes are required as follows: for a climbing ACAS aircraft the SLC command shall be increased at the appropriate altitude threshold plus the hysteresis value; for a descending ACAS aircraft the SLC command shall be decreased at the appropriate altitude threshold minus the hysteresis value.

4.3.4.3.3 *Pilot SLC command.* For the SLC command set by the pilot the value 0 shall indicate the selection of the “automatic” mode for which the sensitivity level selection shall be based on the other commands.

Table 4-2

<i>Sensitivity level</i>	2	3	4	5	6	7
Nominal warning time	no RAs	15s	20s	25s	30s	35s

4.3.4.3.4 *Mode S ground station SLC command.* For SLC commands transmitted via Mode S ground stations (4.3.8.4.2.1.1), the value 0 shall indicate that the station concerned is not issuing an SLC command and that sensitivity level selection shall be based on the other commands, including non-0 commands from other Mode S ground stations. ACAS shall not process an uplinked SLC value of 1.

4.3.4.3.4.1 *ATS selection of SLC command code.* ATS authorities shall ensure that procedures are in place to inform pilots of any ATS selected SLC command code other than 0 (4.3.4.3.1).

4.3.4.3.5 *Selection rule.* Own ACAS sensitivity level shall be set to the smallest non-0 SLC command received from any of the sources listed in 4.3.4.3.

4.3.4.4 *Selection of parameter values for RA generation.* When the sensitivity level of own ACAS is 3 or greater, the parameter values used for RA generation that depend on sensitivity level shall be based on the greater of the sensitivity level of own ACAS,  $S_o$ , and the sensitivity level of the intruder's ACAS,  $S_i$ .

4.3.4.5 *Selection of parameter values for TA generation.* The parameter values used for TA generation that depend on sensitivity level shall be selected on the same basis as those for RAs (4.3.4.4) except when an SLC command with a value of 2 ("TA only" mode) has been received from either the pilot or a Mode S ground station. In this case, the parameter values for TA generation shall retain the values they would have had in the absence of the SLC command from the pilot or Mode S ground station.

### 4.3.5 Resolution advisories (RAs)

4.3.5.1 *RA generation.* For all threats, ACAS shall generate an RA except where it is not possible to select an RA that can be predicted to provide adequate separation either because of uncertainty in the diagnosis of the intruder's flight path or because there is a high risk that a manoeuvre by the threat will negate the RA.

4.3.5.1.1 *Display of threats.* If threats are shown on a traffic display, they shall be displayed in red.

*Note.— This colour is generally considered suitable for indicating a warning condition.*

4.3.5.1.2 *RA cancellation.* Once an RA has been generated against a threat or threats it shall be maintained or modified until tests that are less stringent than those for threat detection indicate on two consecutive cycles that the RA may be cancelled, at which time it shall be cancelled.

4.3.5.2 *RA selection.* ACAS shall generate the RA that is predicted to provide adequate separation from all threats and that has the least effect on the current flight path of the ACAS aircraft consistent with the other provisions in this chapter.

4.3.5.3 *RA effectiveness.* The RA shall not recommend or continue to recommend a manoeuvre or manoeuvre restriction that, considering the range of probable threat trajectories, is more likely to reduce separation than increase it, subject to the provisions in 4.3.5.5.1.1 and 4.3.5.6.

*Note.— See also 4.3.5.8.*

4.3.5.3.1 New ACAS installations after 1 January 2014 shall monitor own aircraft's vertical rate to verify compliance with the RA sense. If non-compliance is detected, ACAS shall stop assuming compliance, and instead shall assume the observed vertical rate.

*Note 1.— This overcomes the retention of an RA sense that would work only if followed. The revised vertical rate assumption is more likely to allow the logic to select the opposite sense when it is consistent with the non-complying aircraft's vertical rate.*

*Note 2.— Equipment complying with RTCA/DO-185 or DO-185A standards (also known as TCAS Version 6.04A or TCAS Version 7.0) do not comply with this requirement.*

*Note 3.— Compliance with this requirement can be achieved through the implementation of traffic alert and collision avoidance system (TCAS) Version 7.1 as specified in RTCA/DO-185B or EUROCAE/ED-143.*

4.3.5.3.2 **Recommendation.**— All ACAS should be compliant with the requirement in 4.3.5.3.1.

4.3.5.3.3 After 1 January 2017, all ACAS units shall comply with the requirements stated in 4.3.5.3.1.

4.3.5.4 *Aircraft capability.* The RA generated by ACAS shall be consistent with the performance capability of the aircraft.

4.3.5.4.1 *Proximity to the ground.* Descend RAs shall not be generated or maintained when own aircraft is below 300 m (1 000 ft) AGL.

4.3.5.4.2 ACAS shall not operate in sensitivity levels 3-7 when own aircraft is below 300 m (1 000 ft) AGL.

4.3.5.5 *Reversals of sense.* ACAS shall not reverse the sense of an RA from one cycle to the next, except as permitted in 4.3.5.5.1 to ensure coordination or when the predicted separation at closest approach for the existing sense is inadequate.

4.3.5.5.1 *Sense reversals against equipped threats.* If an RAC received from an equipped threat is incompatible with the current RA sense, ACAS shall modify the RA sense to conform with the received RAC if own aircraft address is higher in value than that of the threat.

*Note.— 4.3.6.1.3 requires that the own ACAS RAC for the threat is also reversed.*

4.3.5.5.1.1 ACAS shall not modify an RA sense in a way that makes it incompatible with an RAC received from an equipped threat if own aircraft address is higher in value than that of the threat.

4.3.5.6 *RA strength retention.* Subject to the requirement that a descend RA is not generated at low altitude (4.3.5.4.1), an RA shall not be modified if the time to closest approach is too short to achieve a significant response or if the threat is diverging in range.

4.3.5.7 *Weakening an RA.* An RA shall not be weakened if it is likely that it would subsequently need to be strengthened.

4.3.5.8 *ACAS-equipped threats.* The RA shall be compatible with all the RACs transmitted to threats (4.3.6.1.3). If an RAC is received from a threat before own ACAS generates an RAC for that threat, the RA generated shall be compatible with the RAC received unless such an RA is more likely to reduce separation than increase it and own aircraft address is lower in value than that of the threat.

*Note.— In encounters with more than one threat where it is necessary to pass above some threats and below other threats, this standard can be interpreted as referring to the whole duration of the RA. Specifically, it is permissible to retain an RA to climb (descend) towards a threat that is above (below) own aircraft provided there is a calculated intention to provide adequate separation from all threats by subsequently levelling-off.*

4.3.5.9 *Encoding of ARA subfield.* On each cycle of an RA, the RA sense, strength and attributes shall be encoded in the active RA (ARA) subfield (4.3.8.4.2.2.1.1). If the ARA subfield has not been refreshed for an interval of 6 s, it shall be set to 0, along with the MTE subfield in the same message (4.3.8.4.2.2.1.3).

4.3.5.10 *System response time.* The system delay from receipt of the relevant SSR reply to presentation of an RA sense and strength to the pilot shall be as short as possible and shall not exceed 1.5 s.

### 4.3.6 Coordination and communication

#### 4.3.6.1 PROVISIONS FOR COORDINATION WITH ACAS-EQUIPPED THREATS

4.3.6.1.1 *Multi-aircraft coordination.* In a multi-aircraft situation, ACAS shall coordinate with each equipped threat individually.

4.3.6.1.2 *Data protection during coordination.* ACAS shall prevent simultaneous access to stored data by concurrent processes, in particular, during resolution message processing.

4.3.6.1.3 *Coordination interrogation.* Each cycle ACAS shall transmit a coordination interrogation to each equipped threat, unless generation of an RA is delayed because it is not possible to select an RA that can be predicted to provide adequate separation (4.3.5.1). The resolution message transmitted to a threat shall include an RAC selected for that threat. If an RAC has been received from the threat before ACAS selects an RAC for that threat, the selected RAC shall be compatible with the received RAC unless no more than three cycles have elapsed since the RAC was received, the RAC is altitude-crossing, and own aircraft address is lower in value than that of the threat in which case ACAS shall select its RA independently. If an RAC received from an equipped threat is incompatible with the RAC own ACAS has selected for that threat, ACAS shall modify the selected RAC to be compatible with the received RAC if own aircraft address is higher in value than that of the threat.

*Note.— The RAC included in the resolution message is in the form of a vertical RAC (VRC) for ACAS II (4.3.8.4.2.3.2.2) and a vertical RAC (VRC) and/or horizontal RAC (HRC) for ACAS III.*

4.3.6.1.3.1 *Coordination termination.* Within the cycle during which an intruder ceases to be a reason for maintaining the RA, ACAS shall send a resolution message to that intruder by means of a coordination interrogation. The resolution message shall include the cancellation code for the last RAC sent to that intruder while it was a reason for maintaining the RA.

*Note.— During an encounter with a single threat, the threat ceases to be a reason for the RA when the conditions for cancelling the RA are met. During an encounter with multiple threats, a threat ceases to be a reason for the RA when the conditions for cancelling the RA are met in respect of that threat, even though the RA may have to be maintained because of other threats.*

4.3.6.1.3.2 ACAS coordination interrogations shall be transmitted until a coordination reply is received from the threat, up to a maximum of not less than six and not more than twelve attempts. The successive interrogations shall be nominally equally spaced over a period of  $100 \pm 5$  ms. If the maximum number of attempts is made and no reply is received, ACAS shall continue its regular processing sequence.

4.3.6.1.3.3 ACAS shall provide parity protection (4.3.8.4.2.3.2.6 and 4.3.8.4.2.3.2.7) for all fields in the coordination interrogation that convey RAC information.

*Note.— This includes the vertical RAC (VRC), the cancel vertical RAC (CVC), the horizontal RAC (HRC) and the cancel horizontal RAC (CHC).*

4.3.6.1.3.4 Whenever own ACAS reverses its sense against an equipped threat, the resolution message that is sent on the current and subsequent cycles to that threat shall contain both the newly selected RAC and the cancellation code for the RAC sent before the reversal.

4.3.6.1.3.5 When a vertical RA is selected, the vertical RAC (VRC) (4.3.8.4.2.3.2.2) that own ACAS includes in a resolution message to the threat shall be as follows:

- a) “do not pass above” when the RA is intended to provide separation above the threat;
- b) “do not pass below” when the RA is intended to provide separation below the threat.

4.3.6.1.4 *Resolution message processing.* Resolution messages shall be processed in the order in which they are received and with delay limited to that required to prevent possible concurrent access to stored data and delays due to the processing of previously received resolution messages. Resolution messages that are being delayed shall be temporarily queued to prevent possible loss of messages. Processing a resolution message shall include decoding the message and updating the appropriate data structures with the information extracted from the message.

*Note.*— According to 4.3.6.1.2, resolution message processing must not access any data whose usage is not protected by the coordination lock state.

4.3.6.1.4.1 An RAC or an RAC cancellation received from another ACAS shall be rejected if the encoded sense bits indicate the existence of a parity error or if undefined value(s) are detected in the resolution message. An RAC or an RAC cancellation received without parity errors and without undefined resolution message values shall be considered valid.

4.3.6.1.4.2 *RAC storage.* A valid RAC received from another ACAS shall be stored or shall be used to update the previously stored RAC corresponding to that ACAS. A valid RAC cancellation shall cause the previously stored RAC to be deleted. A stored RAC that has not been updated for an interval of 6 s shall be deleted.

4.3.6.1.4.3 *RAC record update.* A valid RAC or RAC cancellation received from another ACAS shall be used to update the RAC record. If a bit in the RAC record has not been refreshed for an interval of 6 s by any threat, that bit shall be set to 0.

#### 4.3.6.2 PROVISIONS FOR ACAS COMMUNICATION WITH GROUND STATIONS

4.3.6.2.1 *Air-initiated downlink of ACAS RAs.* When an ACAS RA exists, ACAS shall:

- a) transfer to its Mode S transponder an RA report for transmission to the ground in a Comm-B reply (4.3.11.4.1); and
- b) transmit periodic RA broadcasts (4.3.7.3.2).

4.3.6.2.2 *Sensitivity level control (SLC) command.* ACAS shall store SLC commands from Mode S ground stations. An SLC command received from a Mode S ground station shall remain effective until replaced by an SLC command from the same ground station as indicated by the site number contained in the IIS subfield of the interrogation. If an existing stored command from a Mode S ground station is not refreshed within 4 minutes, or if the SLC command received has the value 15 (4.3.8.4.2.1.1), the stored SLC command for that Mode S ground station shall be set to 0.

#### 4.3.6.3 PROVISIONS FOR DATA TRANSFER BETWEEN ACAS AND ITS MODE S TRANSPONDER

4.3.6.3.1 *Data transfer from ACAS to its Mode S transponder:*

- a) ACAS shall transfer RA information to its Mode S transponder for transmission in an RA report (4.3.8.4.2.2.1) and in a coordination reply (4.3.8.4.2.4.2);



- b) ACAS shall transfer current sensitivity level to its Mode S transponder for transmission in a sensitivity level report (4.3.8.4.2.5); and
- c) ACAS shall transfer capability information to its Mode S transponder for transmission in a data link capability report (4.3.8.4.2.2.2).

#### 4.3.6.3.2 Data transfer from Mode S transponder to its ACAS:

- a) ACAS shall receive from its Mode S transponder sensitivity level control commands (4.3.8.4.2.1.1) transmitted by Mode S ground stations;
- b) ACAS shall receive from its Mode S transponder ACAS broadcast messages (4.3.8.4.2.3.3) transmitted by other ACAS; and
- c) ACAS shall receive from its Mode S transponder resolution messages (4.3.8.4.2.3.2) transmitted by other ACAS for air-air coordination purposes.

### 4.3.7 ACAS protocols

#### 4.3.7.1 SURVEILLANCE PROTOCOLS

##### 4.3.7.1.1 SURVEILLANCE OF MODE A/C TRANSPONDERS

4.3.7.1.1.1 ACAS shall use the Mode C-only all-call interrogation (Chapter 3, 3.1.2.1.5.1.2) for surveillance of aircraft equipped with Mode A/C transponders.

4.3.7.1.1.2 Using a sequence of interrogations with increasing power, surveillance interrogations shall be preceded by an S<sub>1</sub>-pulse (Chapter 3, 3.1.1.7.4.3) to reduce interference and improve Mode A/C target detection.

##### 4.3.7.1.2 SURVEILLANCE OF MODE S TRANSPONDERS

4.3.7.1.2.1 *Detection.* ACAS shall monitor 1 090 MHz for Mode S acquisition squitters (DF = 11). ACAS shall detect the presence and determine the address of Mode S-equipped aircraft using their Mode S acquisition squitters (DF = 11) or extended squitters (DF = 17).

*Note 1.— It is acceptable to acquire individual aircraft using either acquisition or extended squitters (DF = 11 or DF = 17), and to monitor for both squitters. However, ACAS must monitor for acquisition squitters because, at any time, not all aircraft will transmit the extended squitter.*

*Note 2.— If, in the future, it becomes permitted for aircraft not to transmit the acquisition squitter, relying instead on continual transmission of the extended squitter, it would become essential for all ACAS units to monitor for both the acquisition and the extended squitters.*

4.3.7.1.2.2 *Surveillance interrogations.* On first receipt of a 24-bit aircraft address from an aircraft that is determined to be within the reliable surveillance range of ACAS based on reception reliability and that is within an altitude band 3 050 m (10 000 ft) above and below own aircraft, ACAS shall transmit a short air-air interrogation (UF = 0) for range acquisition. Surveillance interrogations shall be transmitted at least once every five cycles when this altitude condition is satisfied.

Surveillance interrogations shall be transmitted each cycle if the range of the detected aircraft is less than 5.6 km (3 NM) or the calculated time to closest approach is less than 60 s, assuming that both the detected and own aircraft proceed from their current positions with unaccelerated motion and that the range at closest approach equals 5.6 km (3 NM). Surveillance interrogations shall be suspended for a period of five cycles if:

- a) a reply was successfully received; and
- b) own aircraft and intruder aircraft are operating below a pressure-altitude of 5 490 m (18 000 ft); and
- c) the range of the detected aircraft is greater than 5.6 km (3 NM) and the calculated time to closest approach exceeds 60 seconds, assuming that both the detected and own aircraft proceed from their current positions with unaccelerated motion and that the range at closest approach equals 5.6 km (3 NM).

4.3.7.1.2.2.1 *Range acquisition interrogations.* ACAS shall use the short air-air surveillance format (UF = 0) for range acquisition. ACAS shall set AQ = 1 (Chapter 3, 3.1.2.8.1.1) and RL = 0 (Chapter 3, 3.1.2.8.1.2) in an acquisition interrogation.

*Note 1.— Setting AQ = 1 results in a reply with bit 14 of the RI field equal to 1 and serves as an aid in distinguishing the reply to own interrogation from replies elicited from other ACAS units (4.3.7.1.2.2.2).*

*Note 2.— In the acquisition interrogation RL is set to 0 to command a short acquisition reply (DF = 0).*

4.3.7.1.2.2.2 *Tracking interrogations.* ACAS shall use the short air-air surveillance format (UF = 0) with RL = 0 and AQ = 0 for tracking interrogations.

4.3.7.1.2.3 *Surveillance replies.* These protocols are described in 4.3.11.3.1.

4.3.7.1.2.4 *ACAS broadcast.* An ACAS broadcast shall be made nominally every 8 to 10 s at full power from the top antenna. Installations using directional antennas shall operate such that complete circular coverage is provided nominally every 8 to 10 s.

*Note.— A broadcast causes other Mode S transponders to accept the interrogation without replying and to present the interrogation content containing the MU field at the transponder output data interface. The UDS1 = 3, UDS2 = 2 combination identifies the data as an ACAS broadcast containing the 24-bit address of the interrogating ACAS aircraft. This provides each ACAS with a means of determining the number of other ACAS within its detection range for limiting interference. The format of the MU field is described in 4.3.8.4.2.3.*

#### 4.3.7.2 AIR-AIR COORDINATION PROTOCOLS

4.3.7.2.1 *Coordination interrogations.* ACAS shall transmit UF = 16 interrogations (Chapter 3, 3.1.2.3.2, Figure 3-7) with AQ = 0 and RL = 1 when another aircraft reporting RI = 3 or 4 is declared a threat (4.3.4). The MU field shall contain the resolution message in the subfields specified in 4.3.8.4.2.3.2.

*Note 1.— A UF = 16 interrogation with AQ = 0 and RL = 1 is intended to cause a DF = 16 reply from the other aircraft.*

*Note 2.— An aircraft reporting RI = 3 or RI = 4 is an aircraft equipped with an operating ACAS which has vertical only or vertical and horizontal resolution capability, respectively.*

4.3.7.2.2 *Coordination reply.* These protocols are described in 4.3.11.3.2.

## 4.3.7.3 PROTOCOLS FOR ACAS COMMUNICATION WITH GROUND STATIONS

4.3.7.3.1 *RA reports to Mode S ground stations.* These protocols are described in 4.3.11.4.1.

4.3.7.3.2 *RA broadcasts.* RA broadcasts shall be transmitted at full power from the bottom antenna at jittered, nominally 8 s intervals for the period that the RA is indicated. The RA broadcast shall include the MU field as specified in 4.3.8.4.2.3.4. The RA broadcast shall describe the most recent RA that existed during the preceding 8 s period. Installations using directional antennas shall operate such that complete circular coverage is provided nominally every 8 s and the same RA sense and strength is broadcast in each direction.

4.3.7.3.3 *Data link capability report.* These protocols are described in 4.3.11.4.2.

4.3.7.3.4 *ACAS sensitivity level control.* ACAS shall act upon an SLC command if and only if TMS (Chapter 3, 3.1.2.6.1.4.1) has the value 0 and DI is either 1 or 7 in the same interrogation.

## 4.3.8 Signal formats

4.3.8.1 The RF characteristics of all ACAS signals shall conform to the Standards of Chapter 3, 3.1.1.1 through 3.1.1.6, 3.1.2.1 through 3.1.2.3, 3.1.2.5 and 3.1.2.8.

## 4.3.8.2 RELATIONSHIP BETWEEN ACAS AND MODE S SIGNAL FORMATS

*Note.— ACAS uses Mode S transmissions for surveillance and communications. ACAS air-air communication functions permit RA decisions to be coordinated with ACAS-equipped threats. ACAS air-ground communication functions permit the reporting of RAs to ground stations and the uplinking of commands to ACAS-equipped aircraft to control parameters of the collision avoidance algorithms.*

4.3.8.3 *Signal format conventions.* The data encoding of all ACAS signals shall conform to the Standards of Chapter 3, 3.1.2.3.

*Note.— In air-air transmissions used by ACAS, interrogations transmitted at 1 030 MHz are designated as uplink transmissions and contain uplink format (UF) codes. Replies received at 1 090 MHz are designated as downlink transmissions and contain downlink format (DF) codes.*

## 4.3.8.4 FIELD DESCRIPTION

*Note 1.— The air-air surveillance and communication formats which are used by ACAS but not fully described in Chapter 3, 3.1.2 are given in Figure 4-1.*

Uplink:

UF = 0	00000	3	RL:1	4	AQ:1	DS:8	10	AP:24
--------	-------	---	------	---	------	------	----	-------

UF = 16	10000	3	RL:1	4	AQ:1	18	MU:56	AP:24
---------	-------	---	------	---	------	----	-------	-------

Downlink:

DF = 0	00000	VS:1	CC:1	1	SL:3	2	RI:4	2	AC:13	AP:24
--------	-------	------	------	---	------	---	------	---	-------	-------

DF = 16	10000	VS:1	2	SL:3	2	RI:4	2	AC:13	MV:56	AP:24
---------	-------	------	---	------	---	------	---	-------	-------	-------

**Figure 4-1. Surveillance and communication formats used by ACAS**

*Note 2.— This section defines the Mode S fields (and their subfields) that are processed by ACAS to accomplish ACAS functions. Some of the ACAS fields (those also used for other SSR Mode S functions) are described with unassigned ACAS codes in Chapter 3, 3.1.2.6. Such codes are assigned in 4.3.8.4.1. Fields and subfields used only by ACAS equipment are assigned in 4.3.8.4.2.*

*Note 3.— The bit numbering convention used in 4.3.8.4 reflects the bit numbering within the entire uplink or downlink format rather than the bits within individual fields or subfields.*

#### 4.3.8.4.1 FIELDS AND SUBFIELDS INTRODUCED IN CHAPTER 3, 3.1.2

*Note.— Codes for mission fields and subfields that are designated “reserved for ACAS” in Chapter 3, 3.1.2, are specified in this section.*

4.3.8.4.1.1 *DR (downlink request).* The significance of the coding of the downlink request field shall be as follows:

##### *Coding*

0-1	See Chapter 3, 3.1.2.6.5.2
2	ACAS message available
3	Comm-B message available and ACAS message available
4-5	See Chapter 3, 3.1.2.6.5.2
6	Comm-B broadcast message 1 available and ACAS message available
7	Comm-B broadcast message 2 available and ACAS message available
8-31	See Chapter 3, 3.1.2.6.5.2

4.3.8.4.1.2 *RI (air-air reply information).* The significance of the coding in the RI field shall be as follows:

##### *Coding*

0	No operating ACAS
1	Not assigned
2	ACAS with resolution capability inhibited
3	ACAS with vertical-only resolution capability
4	ACAS with vertical and horizontal resolution capability
5-7	Not assigned
8-15	See Chapter 3, 3.1.2.8.2.2

Bit 14 of the reply format containing this field shall replicate the AQ bit of the interrogation. The RI field shall report “no operating ACAS” (RI = 0) if the ACAS unit has failed or is in standby. The RI field shall report “ACAS with resolution capability inhibited” (RI = 2) if sensitivity level is 2 or TA only mode has been selected.

*Note.— Codes 0-7 in the RI field indicate that the reply is a tracking reply and also give the ACAS capability of the interrogated aircraft. Codes 8-15 indicate that the reply is an acquisition reply and also give the maximum true airspeed capability of the interrogated aircraft.*

4.3.8.4.1.3 *RR (reply request).* The significance of the coding in the reply request field shall be as follows:

##### *Coding*

0-18	See Chapter 3, 3.1.2.6.1.2
19	Transmit a resolution advisory report
20-31	See Chapter 3, 3.1.2.6.1.2

## 4.3.8.4.2 ACAS FIELDS AND SUBFIELDS

*Note.*— The following paragraphs describe the location and coding of those fields and subfields that are not defined in Chapter 3, 3.1.2 but are used by aircraft equipped with ACAS.

## 4.3.8.4.2.1 Subfield in MA

4.3.8.4.2.1.1 ADS (A-definition subfield). This 8-bit (33-40) subfield shall define the remainder of MA.

*Note.*— For convenience of coding, ADS is expressed in two groups of four bits each, ADS1 and ADS2.

4.3.8.4.2.1.2 When ADS1 = 0 and ADS2 = 5, the following subfield shall be contained in MA:

4.3.8.4.2.1.3 SLC (ACAS sensitivity level control (SLC) command). This 4-bit (41-44) subfield shall denote a sensitivity level command for own ACAS.

*Coding*

0	No command issued
1	Not assigned
2	Set ACAS sensitivity level to 2
3	Set ACAS sensitivity level to 3
4	Set ACAS sensitivity level to 4
5	Set ACAS sensitivity level to 5
6	Set ACAS sensitivity level to 6
7-14	Not assigned
15	Cancel previous SLC command from this ground station

*Note.*— Structure of MA for a sensitivity level control command:

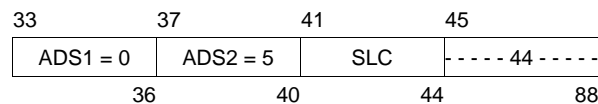

## 4.3.8.4.2.2 Subfields in MB

4.3.8.4.2.2.1 Subfields in MB for an RA report. When BDS1=3 and BDS2=0, the subfields indicated below shall be contained in MB.

*Note.*— The requirements for communication of information relating to the current or recent RAs is described in 4.3.11.4.1.

4.3.8.4.2.2.1.1 ARA (active RAs). This 14-bit (41-54) subfield shall indicate the characteristics of the RA, if any, generated by the ACAS associated with the transponder transmitting the subfield (4.3.6.2.1 a)). The bits in ARA shall have meanings determined by the value of the MTE subfield (4.3.8.4.2.2.1.4) and, for vertical RAs, the value of bit 41 of ARA. The meaning of bit 41 of ARA shall be as follows:

*Coding*

0	There is more than one threat and the RA is intended to provide separation below some threat(s) and above some other threat(s) or no RA has been generated (when MTE = 0)
1	Either there is only one threat or the RA is intended to provide separation in the same direction for all threats

When ARA bit 41 = 1 and MTE = 0 or 1, bits 42-47 shall have the following meanings:

<i>Bit</i>	<i>Coding</i>	
42	0	RA is preventive
	1	RA is corrective
43	0	Upward sense RA has been generated
	1	Downward sense RA has been generated
44	0	RA is not increased rate
	1	RA is increased rate
45	0	RA is not a sense reversal
	1	RA is a sense reversal
46	0	RA is not altitude crossing
	1	RA is altitude crossing
47	0	RA is vertical speed limit
	1	RA is positive
48-54		Reserved for ACAS III

When ARA bit 41 = 0 and MTE = 1, bits 42-47 shall have the following meanings:

<i>Bit</i>	<i>Coding</i>	
42	0	RA does not require a correction in the upward sense
	1	RA requires a correction in the upward sense
43	0	RA does not require a positive climb
	1	RA requires a positive climb
44	0	RA does not require a correction in the downward sense
	1	RA requires a correction in the downward sense
45	0	RA does not require a positive descend
	1	RA requires a positive descend
46	0	RA does not require a crossing
	1	RA requires a crossing
47	0	RA is not a sense reversal
	1	RA is a sense reversal
48-54		Reserved for ACAS III

*Note.*— When ARA bit 41 = 0 and MTE = 0, no vertical RA has been generated.

4.3.8.4.2.2.1.2 *RAC (RACs record)*. This 4-bit (55-58) subfield shall indicate all the currently active RACs, if any, received from other ACAS aircraft. The bits in RAC shall have the following meanings:

<i>Bit</i>	<i>Resolution advisory complement</i>
55	Do not pass below
56	Do not pass above
57	Do not turn left
58	Do not turn right

A bit set to 1 shall indicate that the associated RAC is active. A bit set to 0 shall indicate that the associated RAC is inactive.

4.3.8.4.2.2.1.3 *RAT (RA terminated indicator)*. This 1-bit (59) subfield shall indicate when an RA previously generated by ACAS has ceased being generated.

*Coding*

- 0 ACAS is currently generating the RA indicated in the ARA subfield
- 1 The RA indicated by the ARA subfield has been terminated (4.3.11.4.1)

*Note 1.*— After an RA has been terminated by ACAS, it is still required to be reported by the Mode S transponder for  $18 \pm 1$  s (4.3.11.4.1). The RA terminated indicator may be used, for example, to permit timely removal of an RA indication from an air traffic controller's display, or for assessments of RA duration within a particular airspace.

*Note 2.*— RAs may terminate for a number of reasons: normally, when the conflict has been resolved and the threat is diverging in range; or when the threat's Mode S transponder for some reason ceases to report altitude during the conflict. The RA terminated indicator is used to show that the RA has been removed in each of these cases.

4.3.8.4.2.2.1.4 *MTE (multiple threat encounter)*. This 1-bit (60) subfield shall indicate whether two or more simultaneous threats are currently being processed by the ACAS threat resolution logic.

*Coding*

- 0 One threat is being processed by the resolution logic (when ARA bit 41 = 1); or no threat is being processed by the resolution logic (when ARA bit 41 = 0)
- 1 Two or more simultaneous threats are being processed by the resolution logic

4.3.8.4.2.2.1.5 *TTI (threat type indicator subfield)*. This 2-bit subfield (61-62) shall define the type of identity data contained in the TID subfield.

*Coding*

- 0 No identity data in TID
- 1 TID contains a Mode S transponder address
- 2 TID contains altitude, range and bearing data
- 3 Not assigned

4.3.8.4.2.2.1.6 *TID (threat identity data subfield)*. This 26-bit subfield (63-88) shall contain the Mode S address of the threat or the altitude, range, and bearing if the threat is not Mode S equipped. If two or more threats are simultaneously processed by the ACAS resolution logic, TID shall contain the identity or position data for the most recently declared threat. If TTI = 1, TID shall contain in bits 63-86 the aircraft address of the threat, and bits 87 and 88 shall be set to 0. If TTI = 2, TID shall contain the following three subfields.

4.3.8.4.2.2.1.6.1 *TIDA (threat identity data altitude subfield)*. This 13-bit subfield (63-75) shall contain the most recently reported Mode C altitude code of the threat.

*Coding*

Bit	63	64	65	66	67	68	69	70	71	72	73	74	75
Mode C code bit	C <sub>1</sub>	A <sub>1</sub>	C <sub>2</sub>	A <sub>2</sub>	C <sub>4</sub>	A <sub>4</sub>	0	B <sub>1</sub>	D <sub>1</sub>	B <sub>2</sub>	D <sub>2</sub>	B <sub>4</sub>	D <sub>4</sub>

4.3.8.4.2.2.1.6.2 *TIDR (threat identity data range subfield)*. This 7-bit subfield (76-82) shall contain the most recent threat range estimated by ACAS.

*Coding (n)*

- n* Estimated range (NM)
- 0 No range estimate available
- 1 Less than 0.05
- 2-126  $(n-1)/10 \pm 0.05$
- 127 Greater than 12.55

4.3.8.4.2.2.1.6.3 *TIDB (threat identity data bearing subfield)*. This 6-bit subfield (83-88) shall contain the most recent estimated bearing of the threat aircraft, relative to the ACAS aircraft heading.

<i>Coding (n)</i>	
<i>n</i>	<i>Estimated bearing (degrees)</i>
0	No bearing estimate available
1-60	Between $6(n-1)$ and $6n$
61-63	Not assigned

*Note.*— Structure of MB for an RA report:

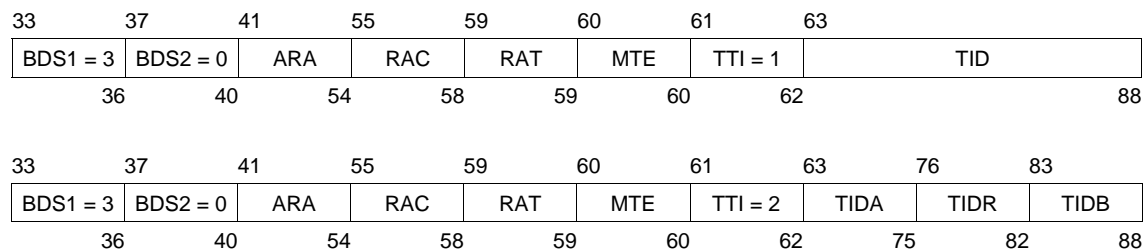

4.3.8.4.2.2.2 *Subfields in MB for the data link capability report*. When BDS1 = 1 and BDS2 = 0, the following bit patterns shall be provided to the transponder for its data link capability report:

<i>Bit</i>	<i>Coding</i>	
48	0	ACAS failed or on standby
	1	ACAS operating
69	0	Hybrid surveillance not operational
	1	Hybrid surveillance fitted and operational
70	0	ACAS generating TAs only
	1	ACAS generating TAs and RAs
Bit 72	Bit 71	ACAS version
0	0	RTCA/DO-185 (pre-ACAS)
0	1	RTCA/DO-185A
1	0	RTCA/DO-185B & EUROCAE ED 143
1	1	Future version (see registers E5 <sub>16</sub> and E6 <sub>16</sub> )

*Note 1.*— A summary of the MB subfields for the data link capability report structure is described in Chapter 3, 3.1.2.6.10.2.2.

*Note 2.*— The use of hybrid surveillance to limit ACAS active interrogations is described in 4.5.1. The ability only to support decoding of DF = 17 extended squitter messages is not sufficient to set bit 72.

4.3.8.4.2.3 *MU field*. This 56-bit (33-88) field of long air-air surveillance interrogations (Figure 4-1) shall be used to transmit resolution messages, ACAS broadcasts and RA broadcasts.

4.3.8.4.2.3.1 *UDS (U-definition subfield)*. This 8-bit (33-40) subfield shall define the remainder of MU.

*Note.*— For convenience in coding, UDS is expressed in two groups of four bits each, UDS1 and UDS2.



4.3.8.4.2.3.2 *Subfields in MU for a resolution message.* When UDS1 = 3 and UDS2 = 0 the following subfields shall be contained in MU:

4.3.8.4.2.3.2.1 *MTB (multiple threat bit).* This 1-bit (42) subfield shall indicate the presence or absence of multiple threats.

*Coding*

- 0 Interrogating ACAS has one threat
- 1 Interrogating ACAS has more than one threat

4.3.8.4.2.3.2.2 *VRC (vertical RAC).* This 2-bit (45-46) subfield shall denote a vertical RAC relating to the addressed aircraft.

*Coding*

- 0 No vertical RAC sent
- 1 Do not pass below
- 2 Do not pass above
- 3 Not assigned

4.3.8.4.2.3.2.3 *CVC (cancel vertical RAC).* This 2-bit (43-44) subfield shall denote the cancellation of a vertical RAC previously sent to the addressed aircraft. This subfield shall be set to 0 for a new threat.

*Coding*

- 0 No cancellation
- 1 Cancel previously sent “Do not pass below”
- 2 Cancel previously sent “Do not pass above”
- 3 Not assigned

4.3.8.4.2.3.2.4 *HRC (horizontal RAC).* This 3-bit (50-52) subfield shall denote a horizontal RAC relating to the addressed aircraft.

*Coding*

- 0 No horizontal RAC or no horizontal resolution capability
- 1 Other ACAS sense is turn left; do not turn left
- 2 Other ACAS sense is turn left; do not turn right
- 3 Not assigned
- 4 Not assigned
- 5 Other ACAS sense is turn right; do not turn left
- 6 Other ACAS sense is turn right; do not turn right
- 7 Not assigned

4.3.8.4.2.3.2.5 *CHC (cancel horizontal RAC).* This 3-bit (47-49) subfield shall denote the cancellation of a horizontal RAC previously sent to the addressed aircraft. This subfield shall be set to 0 for a new threat.

*Coding*

- 0 No cancellation or no horizontal resolution capability
- 1 Cancel previously sent “Do not turn left”
- 2 Cancel previously sent “Do not turn right”
- 3-7 Not assigned

4.3.8.4.2.3.2.6 *VSB (vertical sense bits subfield).* This 4-bit (61-64) subfield shall be used to protect the data in the CVC and VRC subfields. For each of the 16 possible combinations of bits 43-46 the following VSB code shall be transmitted:

Coding	CVC		VRC		VSB			
	43	44	45	46	61	62	63	64
0	0	0	0	0	0	0	0	0
1	0	0	0	1	1	1	1	0
2	0	0	1	0	0	1	1	1
3	0	0	1	1	1	0	0	1
4	0	1	0	0	1	0	1	1
5	0	1	0	1	0	1	0	1
6	0	1	1	0	1	1	0	0
7	0	1	1	1	0	0	1	0
8	1	0	0	0	1	1	0	1
9	1	0	0	1	0	0	1	1
10	1	0	1	0	1	0	1	0
11	1	0	1	1	0	1	0	0
12	1	1	0	0	0	1	1	0
13	1	1	0	1	1	0	0	0
14	1	1	1	0	0	0	0	1
15	1	1	1	1	1	1	1	1

*Note.*— The rule used to generate the VSB subfield bit setting is a distance 3 Hamming code augmented with a parity bit, producing the ability to detect up to three errors in the eight transmitted bits.

4.3.8.4.2.3.2.7 *HSB (horizontal sense bits subfield).* This 5-bit (56-60) subfield shall be used to protect the data in the CHC and HRC subfields. For each of the 64 possible combinations of bits 47-52 the following HSB code shall be transmitted:

Coding	CHC			HRC			HSB				
	47	48	49	50	51	52	56	57	58	59	60
0	0	0	0	0	0	0	0	0	0	0	0
1	0	0	0	0	0	1	0	1	0	1	1
2	0	0	0	0	1	0	1	0	0	1	1
3	0	0	0	0	1	1	1	1	1	0	0
4	0	0	0	1	0	0	1	1	1	1	0
5	0	0	0	1	0	1	1	0	1	1	1
6	0	0	0	1	1	0	0	1	1	1	1
7	0	0	0	1	1	1	1	0	0	1	0
8	0	0	1	0	0	0	0	0	1	1	0
9	0	0	1	0	0	1	0	0	0	1	0
10	0	0	1	0	1	0	1	1	1	1	0
11	0	0	1	0	1	1	1	0	1	0	1
12	0	0	1	1	0	0	1	0	0	0	1
13	0	0	1	1	0	1	1	1	1	0	0
14	0	0	1	1	1	0	0	0	0	1	0
15	0	0	1	1	1	1	0	1	0	0	1
16	0	1	0	0	0	0	1	0	1	0	1
17	0	1	0	0	0	1	1	1	1	1	0
18	0	1	0	0	1	0	0	0	0	1	0
19	0	1	0	0	1	1	0	1	1	0	1
20	0	1	0	1	0	0	0	1	0	0	1
21	0	1	0	1	0	1	0	0	0	1	0
22	0	1	0	1	1	0	1	1	0	1	0
23	0	1	0	1	1	1	1	0	0	0	1
24	0	1	1	0	0	0	1	1	0	0	0
25	0	1	1	0	0	1	1	0	0	1	1

Coding	CHC					HRC		HSB				
	47	48	49	50	51	52	56	57	58	59	60	
26	0	1	1	0	1	0	0	1	0	1	1	
27	0	1	1	0	1	1	0	0	0	0	0	
28	0	1	1	1	0	0	0	0	1	0	0	
29	0	1	1	1	0	1	0	1	1	1	1	
30	0	1	1	1	1	0	1	0	1	1	1	
31	0	1	1	1	1	1	1	1	1	0	0	
32	1	0	0	0	0	0	1	1	0	0	1	
33	1	0	0	0	0	1	1	0	0	1	0	
34	1	0	0	0	1	0	0	1	0	1	0	
35	1	0	0	0	1	1	0	0	0	0	1	
36	1	0	0	1	0	0	0	0	1	0	1	
37	1	0	0	1	0	1	0	1	1	1	0	
38	1	0	0	1	1	0	1	0	1	1	0	
39	1	0	0	1	1	1	1	1	1	0	1	
40	1	0	1	0	0	0	1	0	1	0	0	
41	1	0	1	0	0	1	1	1	1	1	1	
42	1	0	1	0	1	0	0	0	1	1	1	
43	1	0	1	0	1	1	0	1	1	0	0	
44	1	0	1	1	0	0	0	1	0	0	0	
45	1	0	1	1	0	1	0	0	0	1	1	
46	1	0	1	1	1	0	1	1	0	1	1	
47	1	0	1	1	1	1	1	0	0	0	0	
48	1	1	0	0	0	0	0	1	1	0	0	
49	1	1	0	0	0	1	0	0	1	1	1	
50	1	1	0	0	1	0	1	1	1	1	1	
51	1	1	0	0	1	1	1	0	1	0	0	
52	1	1	0	1	0	0	1	0	0	0	0	
53	1	1	0	1	0	1	1	1	0	1	1	
54	1	1	0	1	1	0	0	0	0	1	1	
55	1	1	0	1	1	1	0	1	0	0	0	
56	1	1	1	0	0	0	0	0	0	0	1	
57	1	1	1	0	0	1	0	1	0	1	0	
58	1	1	1	0	1	0	1	0	0	1	0	
59	1	1	1	0	1	1	1	1	0	0	1	
60	1	1	1	1	0	0	1	1	1	0	1	
61	1	1	1	1	0	1	1	0	1	1	0	
62	1	1	1	1	1	0	0	1	1	1	0	
63	1	1	1	1	1	1	0	0	1	0	1	

Note.— The rule used to generate the HSB subfield bit setting is a distance 3 Hamming code augmented with a parity bit, producing the ability to detect up to three errors in the eleven transmitted bits.

4.3.8.4.2.3.2.8 MID (Aircraft address). This 24-bit (65-88) subfield shall contain the 24-bit aircraft address of the interrogating ACAS aircraft.

Note.— Structure of MU for a resolution message:

33	37	41	42	43	45	47	50	53	56	61	65
UDS1 = 3	UDS2 = 0	-1-	MTB	CVC	VRC	CHC	HRC	-3-	HSB	VSB	MID
36	40	41	42	44	46	49	52	55	60	64	88

4.3.8.4.2.3.3 *Subfield in MU for an ACAS broadcast.* When UDS1 = 3 and UDS2 = 2, the following subfield shall be contained in MU:

4.3.8.4.2.3.3.1 *MID (Aircraft address).* This 24-bit (65-88) subfield shall contain the 24-bit aircraft address of the interrogating ACAS aircraft.

*Note.*— Structure of MU for an ACAS broadcast:

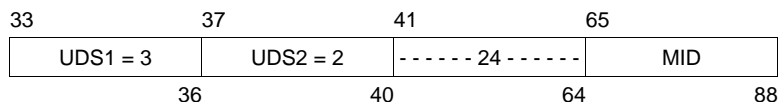

4.3.8.4.2.3.4 *Subfields in MU for an RA broadcast.* When UDS1 = 3 and UDS2 = 1, the following subfields shall be contained in MU:

4.3.8.4.2.3.4.1 *ARA (active RAs).* This 14-bit (41-54) subfield shall be coded as defined in 4.3.8.4.2.2.1.1.

4.3.8.4.2.3.4.2 *RAC (RACs record).* This 4-bit (55-58) subfield shall be coded as defined in 4.3.8.4.2.2.1.2.

4.3.8.4.2.3.4.3 *RAT (RA terminated indicator).* This 1-bit (59) subfield shall be coded as defined in 4.3.8.4.2.2.1.3.

4.3.8.4.2.3.4.4 *MTE (multiple threat encounter).* This 1-bit (60) subfield shall be coded as defined in 4.3.8.4.2.2.1.4.

4.3.8.4.2.3.4.5 *AID (Mode A identity code).* This 13-bit (63-75) subfield shall denote the Mode A identity code of the reporting aircraft.

*Coding*

Bit	63	64	65	66	67	68	69	70	71	72	73	74	75
Mode A code bit	A <sub>4</sub>	A <sub>2</sub>	A <sub>1</sub>	B <sub>4</sub>	B <sub>2</sub>	B <sub>1</sub>	0	C <sub>4</sub>	C <sub>2</sub>	C <sub>1</sub>	D <sub>4</sub>	D <sub>2</sub>	D <sub>1</sub>

4.3.8.4.2.3.4.6 *CAC (Mode C altitude code).* This 13-bit (76-88) subfield shall denote the Mode C altitude code of the reporting aircraft.

*Coding*

Bit	76	77	78	79	80	81	82	83	84	85	86	87	88
Mode C code bit	C <sub>1</sub>	A <sub>1</sub>	C <sub>2</sub>	A <sub>2</sub>	C <sub>4</sub>	A <sub>4</sub>	0	B <sub>1</sub>	D <sub>1</sub>	B <sub>2</sub>	D <sub>2</sub>	B <sub>4</sub>	D <sub>4</sub>

*Note.*— Structure of MU for an RA broadcast:

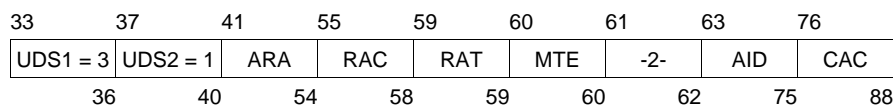

4.3.8.4.2.4 *MV field.* This 56-bit (33-88) field of long air-air surveillance replies (Figure 4-1) shall be used to transmit air-air coordination reply messages.

4.3.8.4.2.4.1 *VDS (V-definition subfield).* This 8-bit (33-40) subfield shall define the remainder of MV.

*Note.*— For convenience in coding, VDS is expressed in two groups of four bits each, VDS1 and VDS2.

4.3.8.4.2.4.2 *Subfields in MV for a coordination reply.* When VDS1 = 3 and VDS2 = 0, the following subfields shall be contained in MV:

4.3.8.4.2.4.2.1 *ARA (active RAs).* This 14-bit (41-54) subfield shall be coded as defined in 4.3.8.4.2.2.1.1.

4.3.8.4.2.4.2.2 *RAC (RACs record).* This 4-bit (55-58) subfield shall be coded as defined in 4.3.8.4.2.2.1.2.

4.3.8.4.2.4.2.3 *RAT (RA terminated indicator).* This 1-bit (59) subfield shall be coded as defined in 4.3.8.4.2.2.1.3.

4.3.8.4.2.4.2.4 *MTE (multiple threat encounter).* This 1-bit (60) subfield shall be coded as defined in 4.3.8.4.2.2.1.4.

*Note.*— Structure of MV for a coordination reply:

33	37	41	55	59	60	61	
VDS1 = 3	VDS2 = 0	ARA	RAC	RAT	MTE	-28-	
	36	40	54	58	59	60	88

4.3.8.4.2.5 *SL (sensitivity level report).* This 3-bit (9-11) downlink field shall be included in both short and long air-air reply formats (DF = 0 and 16). This field shall denote the sensitivity level at which ACAS is currently operating.

*Coding*

- 0 ACAS inoperative
- 1 ACAS is operating at sensitivity level 1
- 2 ACAS is operating at sensitivity level 2
- 3 ACAS is operating at sensitivity level 3
- 4 ACAS is operating at sensitivity level 4
- 5 ACAS is operating at sensitivity level 5
- 6 ACAS is operating at sensitivity level 6
- 7 ACAS is operating at sensitivity level 7

4.3.8.4.2.6 *CC: Cross-link capability.* This 1-bit (7) downlink field shall indicate the ability of the transponder to support the cross-link capability, i.e. decode the contents of the DS field in an interrogation with UF equals 0 and respond with the contents of the specified GICB register in the corresponding reply with DF equals 16.

*Coding*

- 0 signifies that the transponder cannot support the cross-link capability.
- 1 signifies that the transponder supports the cross-link capability.

### 4.3.9 ACAS equipment characteristics

4.3.9.1 *Interfaces.* As a minimum, the following input data shall be provided to the ACAS:

- a) aircraft address code;
- b) air-air and ground-air Mode S transmissions received by the Mode S transponder for use by ACAS (4.3.6.3.2);
- c) own aircraft's maximum cruising true airspeed capability (Chapter 3, 3.1.2.8.2.2);

- d) pressure-altitude; and
- e) radio altitude.

*Note.*— *Specific requirements for additional inputs for ACAS II and III are listed in the appropriate sections below.*

4.3.9.2 *Aircraft antenna system.* ACAS shall transmit interrogations and receive replies via two antennas, one mounted on the top of the aircraft and the other on the bottom of the aircraft. The top-mounted antenna shall be directional and capable of being used for direction finding.

4.3.9.2.1 *Polarization.* Polarization of ACAS transmissions shall be nominally vertical.

4.3.9.2.2 *Radiation pattern.* The radiation pattern in elevation of each antenna when installed on an aircraft shall be nominally equivalent to that of a quarter-wave monopole on a ground plane.

#### 4.3.9.2.3 ANTENNA SELECTION

4.3.9.2.3.1 *Squitter reception.* ACAS shall be capable of receiving squitters via the top and bottom antennas.

4.3.9.2.3.2 *Interrogations.* ACAS interrogations shall not be transmitted simultaneously on both antennas.

4.3.9.3 *Pressure-altitude source.* The altitude data for own aircraft provided to ACAS shall be obtained from the source that provides the basis for own Mode C or Mode S reports and they shall be provided at the finest quantization available.

4.3.9.3.1 **Recommendation.**— *A source providing a resolution finer than 7.62 m (25 ft) should be used.*

4.3.9.3.2 Where a source providing a resolution finer than 7.62 m (25 ft) is not available, and the only altitude data available for own aircraft is Gilham encoded, at least two independent sources shall be used and compared continuously in order to detect encoding errors.

4.3.9.3.3 **Recommendation.**— *Two altitude data sources should be used and compared in order to detect errors before provision to ACAS.*

4.3.9.3.4 The provisions of 4.3.10.3 shall apply when the comparison of the two altitude data sources indicates that one of the sources is in error.

### 4.3.10 Monitoring

4.3.10.1 *Monitoring function.* ACAS shall continuously perform a monitoring function in order to provide a warning if any of the following conditions at least are satisfied:

- a) there is no interrogation power limiting due to interference control (4.3.2.2.2) and the maximum radiated power is reduced to less than that necessary to satisfy the surveillance requirements specified in 4.3.2; or
- b) any other failure in the equipment is detected which results in a reduced capability of providing TAs or RAs; or
- c) data from external sources indispensable for ACAS operation are not provided, or the data provided are not credible.

4.3.10.2 *Effect on ACAS operation.* The ACAS monitoring function shall not adversely affect other ACAS functions.

4.3.10.3 *Monitoring response.* When the monitoring function detects a failure (4.3.10.1), ACAS shall:

- a) indicate to the flight crew that an abnormal condition exists;
- b) prevent any further ACAS interrogations; and
- c) cause any Mode S transmission containing own aircraft's resolution capability to indicate that ACAS is not operating.

#### **4.3.11 Requirements for a Mode S transponder used in conjunction with ACAS**

4.3.11.1 *Transponder capabilities.* In addition to the minimum transponder capabilities defined in Chapter 3, 3.1, the Mode S transponder used in conjunction with ACAS shall have the following capabilities:

- a) ability to handle the following formats:

<i>Format No.</i>	<i>Format name</i>
UF = 16	Long air-air surveillance interrogation
DF = 16	Long air-air surveillance reply

- b) ability to receive long Mode S interrogations (UF = 16) and generate long Mode S replies (DF = 16) at a continuous rate of 16.6 ms (60 per second);
- c) means for delivering the ACAS data content of all accepted interrogations addressed to the ACAS equipment;
- d) antenna diversity (as specified in Chapter 3, 3.1.2.10.4);
- e) mutual suppression capability; and
- f) inactive state transponder output power restriction.

When the Mode S transponder transmitter is in the inactive state, the peak pulse power at 1 090 MHz  $\pm$ 3 MHz at the terminals of the Mode S transponder antenna shall not exceed  $-70$  dBm.

#### 4.3.11.2 DATA TRANSFER BETWEEN ACAS AND ITS MODE S TRANSPONDER

4.3.11.2.1 *Data transfer from ACAS to its Mode S transponder:*

- a) The Mode S transponder shall receive from its ACAS RA information for transmission in an RA report (4.3.8.4.2.2.1) and in a coordination reply (4.3.8.4.2.4.2);
- b) the Mode S transponder shall receive from its ACAS current sensitivity level for transmission in a sensitivity level report (4.3.8.4.2.5);
- c) the Mode S transponder shall receive from its ACAS capability information for transmission in a data link capability report (4.3.8.4.2.2.2) and for transmission in the RI field of air-air downlink formats DF = 0 and DF = 16 (4.3.8.4.1.2); and
- d) the Mode S transponder shall receive from its ACAS an indication that RAs are enabled or inhibited for transmission in the RI field of downlink formats 0 and 16.

## 4.3.11.2.2 Data transfer from Mode S transponder to its ACAS:

- a) The Mode S transponder shall transfer to its ACAS received sensitivity level control commands (4.3.8.4.2.1.1) transmitted by Mode S stations;
- b) the Mode S transponder shall transfer to its ACAS received ACAS broadcast messages (4.3.8.4.2.3.3) transmitted by other ACASs;
- c) the Mode S transponder shall transfer to its ACAS received resolution messages (4.3.8.4.2.3.2) transmitted by other ACASs for air-air coordination purposes; and
- d) the Mode S transponder shall transfer to its ACAS own aircraft's Mode A identity data for transmission in an RA broadcast (4.3.8.4.2.3.4.5).

4.3.11.3 COMMUNICATION OF ACAS  
INFORMATION TO OTHER ACAS

4.3.11.3.1 *Surveillance reply.* The ACAS Mode S transponder shall use the short (DF = 0) or long (DF = 16) surveillance formats for replies to ACAS surveillance interrogations. The surveillance reply shall include the VS field as specified in Chapter 3, 3.1.2.8.2, the RI field as specified in Chapter 3, 3.1.2.8.2 and in 4.3.8.4.1.2, and the SL field as specified in 4.3.8.4.2.5.

4.3.11.3.2 *Coordination reply.* The ACAS Mode S transponder shall transmit a coordination reply upon receipt of a coordination interrogation from an equipped threat subject to the conditions of 4.3.11.3.2.1. The coordination reply shall use the long air-air surveillance reply format, DF = 16, with the VS field as specified in Chapter 3, 3.1.2.8.2, the RI field as specified in Chapter 3, 3.1.2.8.2 and in 4.3.8.4.1.2, the SL field as specified in 4.3.8.4.2.5 and the MV field as specified in 4.3.8.4.2.4. Coordination replies shall be transmitted even if the minimum reply rate limits of the transponder (Chapter 3, 3.1.2.10.3.7.2) are exceeded.

4.3.11.3.2.1 The ACAS Mode S transponder shall reply with a coordination reply to a coordination interrogation received from another ACAS if and only if the transponder is able to deliver the ACAS data content of the interrogation to its associated ACAS.

4.3.11.4 COMMUNICATION OF ACAS  
INFORMATION TO GROUND STATIONS

4.3.11.4.1 *RA reports to Mode S ground stations.* During the period of an RA and for  $18 \pm 1$  s following the end of the RA, the ACAS Mode S transponder shall indicate that it has an RA report by setting the appropriate DR field code in replies to a Mode S sensor as specified in 4.3.8.4.1.1. The RA report shall include the MB field as specified in 4.3.8.4.2.2.1. The RA report shall describe the most recent RA that existed during the preceding  $18 \pm 1$  s period.

*Note 1.— The last sentence of 4.3.11.4.1 means that for  $18 \pm 1$  s following the end of an RA, all MB subfields in the RA report with the exception of bit 59 (RA terminated indicator) will retain the information reported at the time the RA was last active.*

*Note 2.— Upon receipt of a reply with DR = 2, 3, 6 or 7, a Mode S ground station may request downlink of the RA report by setting RR = 19 and either DI = 7, or DI = 7 and RRS = 0 in a surveillance or Comm-A interrogation to the ACAS aircraft. When this interrogation is received, the transponder replies with a Comm-B reply whose MB field contains the RA report.*

4.3.11.4.2 *Data link capability report.* The presence of an ACAS shall be indicated by its Mode S transponder to a ground station in the Mode S data link capability report.



*Note.*— This indication causes the transponder to set codes in a data link capability report as specified in 4.3.8.4.2.2.2.

#### 4.3.12 Indications to the flight crew

##### 4.3.12.1 CORRECTIVE AND PREVENTIVE RAS

**Recommendation.**— *Indications to the flight crew should distinguish between preventive and corrective RAs.*

##### 4.3.12.2 ALTITUDE CROSSING RAS

**Recommendation.**— *If ACAS generates an altitude crossing RA, a specific indication should be given to the flight crew that it is crossing.*

### 4.4 PERFORMANCE OF THE ACAS II COLLISION AVOIDANCE LOGIC

*Note.*— *Caution is to be observed when considering potential improvements to the reference ACAS II system described in Section 4 of the guidance material in the Attachment since changes may affect more than one aspect of the system performance. It is essential that alternative designs would not degrade the performances of other designs and that such compatibility is demonstrated with a high degree of confidence.*

#### 4.4.1 Definitions relating to the performance of the collision avoidance logic

*Note.*— *The notation  $[t_1, t_2]$  is used to indicate the interval between  $t_1$  and  $t_2$ .*

**Altitude layer.** Each encounter is attributed to one of six altitude layers as follows:

Layer	1	2	3	4	5	6
from		2 300 ft	5 000 ft	10 000 ft	20 000 ft	41 000 ft
to	2 300 ft	5 000 ft	10 000 ft	20 000 ft	41 000 ft	

The altitude layer of an encounter is determined by the average altitude of the two aircraft at closest approach.

*Note.*— *For the purposes of defining the performance of the collision avoidance logic, there is no need to specify the physical basis of the altitude measurement or the relationship between altitude and ground level.*

**Approach angle.** The difference in the ground headings of the two aircraft at closest approach, with 180 degrees defined as head on and 0 degrees defined as parallel.

**Crossing encounter.** An encounter in which the altitude separation of the two aircraft exceeds 100 ft at the beginning and at the end of the encounter window, and the relative vertical position of two aircraft at the end of the encounter window is reversed from that at the beginning of the encounter window.

THIS PAGE INTENTIONALLY LEFT BLANK.

**Encounter.** For the purposes of defining the performance of the collision avoidance logic, an encounter consists of two simulated aircraft trajectories. The horizontal coordinates of the aircraft represent the actual position of the aircraft but the vertical coordinate represents an altimeter measurement of altitude.

**Encounter class.** Encounters are classified according to whether or not the aircraft are transitioning at the beginning and end of the encounter window, and whether or not the encounter is crossing.

**Encounter window.** The time interval [ $tca - 40$  s,  $tca + 10$  s].

**Horizontal miss distance (hmd).** The minimum horizontal separation observed in an encounter.

**Level aircraft.** An aircraft that is not transitioning.

**Original trajectory.** The original trajectory of an ACAS-equipped aircraft is that followed by the aircraft in the same encounter when it was not ACAS equipped.

**Original rate.** The original rate of an ACAS-equipped aircraft at any time is its altitude rate at the same time when it followed the original trajectory.

**Required rate.** For the standard pilot model, the required rate is that closest to the original rate consistent with the RA.

**tca.** Nominally, the time of closest approach. For encounters in the standard encounter model (4.4.2.6), a reference time for the construction of the encounter at which various parameters, including the vertical and horizontal separation (*vmd* and *hmd*), are specified.

*Note.— Encounters in the standard encounter model (4.4.2.6) are constructed by building the trajectories of the two aircraft outwards starting at tca. When the process is complete, tca may not be the precise time of closest approach and differences of a few seconds are acceptable.*

**Transitioning aircraft.** An aircraft having an average vertical rate with a magnitude exceeding 400 feet per minute (ft/min), measured over some period of interest.

**Turn extent.** A heading difference defined as an aircraft's ground heading at the end of a turn minus its ground heading at the beginning of the turn.

**Vertical miss distance (vmd).** Notionally, the vertical separation at closest approach. For encounters in the standard encounter model (4.4.2.6), by construction the vertical separation at the time *tca*.

#### 4.4.2 Conditions under which the requirements apply

4.4.2.1 The following assumed conditions shall apply to the performance requirements specified in 4.4.3 and 4.4.4:

- a) range and bearing measurements and an altitude report are available for the intruder each cycle as long as it is within 14 NM, but not when the range exceeds 14 NM;
- b) the errors in the range and bearing measurements conform to standard range and bearing error models (4.4.2.2 and 4.4.2.3);
- c) the intruder's altitude reports, which are its Mode C replies, are expressed in 100 ft quanta;
- d) an altitude measurement that has not been quantized and is expressed with a precision of 1 ft or better is available for own aircraft;

- e) errors in the altitude measurements for both aircraft are constant throughout any particular encounter;
- f) the errors in the altitude measurements for both aircraft conform to a standard altimetry error model (4.4.2.4);
- g) the pilot responses to RAs conform to a standard pilot model (4.4.2.5);
- h) the aircraft operate in an airspace in which close encounters, including those in which ACAS generates an RA, conform to a standard encounter model (4.4.2.6);
- i) ACAS-equipped aircraft are not limited in their ability to perform the manoeuvres required by their RAs; and
- j) as specified in 4.4.2.7:
  - 1) the intruder involved in each encounter is not equipped (4.4.2.7 a)); or
  - 2) the intruder is ACAS-equipped but follows a trajectory identical to that in the unequipped encounter (4.4.2.7 b)); or
  - 3) the intruder is equipped with an ACAS having a collision avoidance logic identical to that of own ACAS (4.4.2.7 c)).

*Note.*— The phrase “altitude measurement” refers to a measurement by an altimeter prior to any quantization.

4.4.2.1.1 The performance of the collision avoidance logic shall not degrade abruptly as the statistical distribution of the altitude errors or the statistical distributions of the various parameters that characterize the standard encounter model or the response of pilots to the advisories are varied, when surveillance reports are not available on every cycle or when the quantization of the altitude measurements for the intruder is varied or the altitude measurements for own aircraft are quantized.

#### 4.4.2.2 STANDARD RANGE ERROR MODEL

The errors in the simulated range measurements shall be taken from a Normal distribution with mean 0 ft and standard deviation 50 ft.

#### 4.4.2.3 STANDARD BEARING ERROR MODEL

The errors in the simulated bearing measurements shall be taken from a Normal distribution with mean 0.0 degrees and standard deviation 10.0 degrees.

#### 4.4.2.4 STANDARD ALTIMETRY ERROR MODEL

4.4.2.4.1 The errors in the simulated altitude measurements shall be assumed to be distributed as a Laplacian distribution with zero mean having probability density

$$p(e) = \frac{1}{2\lambda} \exp\left(-\frac{|e|}{\lambda}\right)$$

4.4.2.4.2 The parameter  $\lambda$  required for the definition of the statistical distribution of altimeter error for each aircraft shall have one of two values,  $\lambda_1$  and  $\lambda_2$ , which depend on the altitude layer of the encounter as follows:

Layer	1		2		3		4		5		6	
	<i>m</i>	<i>ft</i>	<i>m</i>	<i>ft</i>	<i>m</i>	<i>ft</i>	<i>m</i>	<i>ft</i>	<i>m</i>	<i>ft</i>	<i>m</i>	<i>ft</i>
$\lambda_1$	10	35	11	38	13	43	17	58	22	72	28	94
$\lambda_2$	18	60	18	60	21	69	26	87	30	101	30	101

4.4.2.4.3 For an aircraft equipped with ACAS the value of  $\lambda$  shall be  $\lambda_1$ .

4.4.2.4.4 For aircraft not equipped with ACAS, the value of  $\lambda$  shall be selected randomly using the following probabilities:

Layer	1	2	3	4	5	6
prob( $\lambda_1$ )	0.391	0.320	0.345	0.610	0.610	0.610
prob( $\lambda_2$ )	0.609	0.680	0.655	0.390	0.390	0.390

#### 4.4.2.5 STANDARD PILOT MODEL

The standard pilot model used in the assessment of the performance of the collision avoidance logic shall be that:

- a) any RA is complied with by accelerating to the required rate (if necessary) after an appropriate delay;
- b) when the aircraft's current rate is the same as its original rate and the original rate complies with the RA, the aircraft continues at its original rate, which is not necessarily constant due to the possibility of acceleration in the original trajectory;
- c) when the aircraft is complying with the RA, its current rate is the same as the original rate and the original rate changes and consequently becomes inconsistent with the RA, the aircraft continues to comply with the RA;
- d) when an initial RA requires a change in altitude rate, the aircraft responds with an acceleration of 0.25 g after a delay of 5 s from the display of the RA;
- e) when an RA is modified and the original rate complies with the modified RA, the aircraft returns to its original rate (if necessary) with the acceleration specified in g) after the delay specified in h);
- f) when an RA is modified and the original rate does not comply with the modified RA, the aircraft responds to comply with the RA with the acceleration specified in g) after the delay specified in h);
- g) the acceleration used when an RA is modified is 0.25 g unless the modified RA is a reversed sense RA or an increased rate RA in which case the acceleration is 0.35 g;
- h) the delay used when an RA is modified is 2.5 s unless this results in the acceleration starting earlier than 5 s from the initial RA in which case the acceleration starts 5 s from the initial RA; and
- i) when an RA is cancelled, the aircraft returns to its original rate (if necessary) with an acceleration of 0.25 g after a delay of 2.5 s.

## 4.4.2.6 STANDARD ENCOUNTER MODEL

## 4.4.2.6.1 ELEMENTS OF THE STANDARD ENCOUNTER MODEL

4.4.2.6.1.1 In order to calculate the effect of ACAS on the risk of collision (4.4.3) and the compatibility of ACAS with air traffic management (ATM) (4.4.4), sets of encounters shall be created for each of:

- a) the two aircraft address orderings;
- b) the six altitude layers;
- c) nineteen encounter classes; and
- d) nine or ten *vmd* bins as specified in 4.4.2.6.2.4.

The results for these sets shall be combined using the relative weightings given in 4.4.2.6.2.

4.4.2.6.1.1.1 Each set of encounters shall contain at least 500 independent, randomly generated encounters.

4.4.2.6.1.1.2 The two aircraft trajectories in each encounter shall be constructed with the following randomly selected characteristics:

- a) in the vertical plane:
  - 1) a *vmd* from within the appropriate *vmd* bin;
  - 2) a vertical rate for each aircraft at the beginning of the encounter window,  $\dot{z}_1$ , and at the end of the encounter window,  $\dot{z}_2$ ;
  - 3) a vertical acceleration; and
  - 4) a start time for the vertical acceleration; and
- b) and in the horizontal plane:
  - 1) an *hmd*;
  - 2) an approach angle;
  - 3) a speed for each aircraft at closest approach;
  - 4) a decision for each aircraft whether or not it turns;
  - 5) the turn extent; the bank angle; and the turn end time;
  - 6) a decision for each aircraft whether or not its speed changes; and
  - 7) the magnitude of the speed change.

*Note.*— It is possible for the selections made for the various characteristics of an encounter to be irreconcilable. When this occurs, the problem can be resolved by discarding either the selection for a particular characteristic or the whole encounter, as most appropriate.

4.4.2.6.1.3 Two models shall be used for the statistical distribution of *hmd* (4.4.2.6.4.1). For calculations of the effect of ACAS on the risk of collision (4.4.3), *hmd* shall be constrained to be less than 500 ft. For calculations of the compatibility of ACAS with ATM (4.4.4), *hmd* shall be selected from a larger range of values (4.4.2.6.4.1.2).

*Note.*— 4.4.2.6.2 and 4.4.2.6.3 specify vertical characteristics for the aircraft trajectories in the standard encounter model that depend on whether the *hmd* is constrained to be small (“for calculating risk ratio”) or can take larger values (“for ATM compatibility”). Otherwise, the characteristics of the encounters in the vertical and horizontal planes are independent.

#### 4.4.2.6.2 ENCOUNTER CLASSES AND WEIGHTS

4.4.2.6.2.1 *Aircraft address.* Each aircraft shall be equally likely to have the higher aircraft address.

4.4.2.6.2.2 *Altitude layers.* The relative weights of the altitude layers shall be as follows:

Layer	1	2	3	4	5	6
prob(layer)	0.13	0.25	0.32	0.22	0.07	0.01

#### 4.4.2.6.2.3 Encounter classes

4.4.2.6.2.3.1 The encounters shall be classified according to whether the aircraft are level (L) or transitioning (T) at the beginning (*before tca*) and end (*after tca*) of the encounter window and whether or not the encounter is crossing, as follows:

Class	Aircraft No. 1		Aircraft No. 2		Crossing
	<i>before tca</i>	<i>after tca</i>	<i>before tca</i>	<i>after tca</i>	
1	L	L	T	T	yes
2	L	L	L	T	yes
3	L	L	T	L	yes
4	T	T	T	T	yes
5	L	T	T	T	yes
6	T	T	T	L	yes
7	L	T	L	T	yes
8	L	T	T	L	yes
9	T	L	T	L	yes
10	L	L	L	L	no
11	L	L	T	T	no
12	L	L	L	T	no
13	L	L	T	L	no
14	T	T	T	T	no
15	L	T	T	T	no
16	T	T	T	L	no
17	L	T	L	T	no
18	L	T	T	L	no
19	T	L	T	L	no

4.4.2.6.2.3.2 The relative weights of the encounter classes shall depend on layer as follows:

Class	for calculating risk ratio		for ATM compatibility	
	Layers 1-3	Layers 4-6	Layers 1-3	Layers 4-6
1	0.00502	0.00319	0.06789	0.07802
2	0.00030	0.00018	0.00408	0.00440
3	0.00049	0.00009	0.00664	0.00220
4	0.00355	0.0027	0.04798	0.06593
5	0.00059	0.00022	0.00791	0.00549
6	0.00074	0.00018	0.00995	0.00440
7	0.00002	0.00003	0.00026	0.00082
8	0.00006	0.00003	0.00077	0.00082
9	0.00006	0.00003	0.00077	0.00082
10	0.36846	0.10693	0.31801	0.09011
11	0.26939	0.41990	0.23252	0.35386
12	0.06476	0.02217	0.05590	0.01868
13	0.07127	0.22038	0.06151	0.18571
14	0.13219	0.08476	0.11409	0.07143
15	0.02750	0.02869	0.02374	0.02418
16	0.03578	0.06781	0.03088	0.05714
17	0.00296	0.00098	0.00255	0.00082
18	0.00503	0.00522	0.00434	0.00440
19	0.01183	0.03651	0.01021	0.03077

#### 4.4.2.6.2.4 vmd bins

4.4.2.6.2.4.1 The *vmd* of each encounter shall be taken from one of ten *vmd* bins for the non-crossing encounter classes, and from one of nine or ten *vmd* bins for the crossing encounter classes. Each *vmd* bin shall have an extent of 100 ft for calculating risk ratio, or an extent of 200 ft for calculating compatibility with ATM. The maximum *vmd* shall be 1 000 ft for calculating risk ratio, and 2 000 ft otherwise.

4.4.2.6.2.4.2 For non-crossing encounter classes, the relative weights of the *vmd* bins shall be as follows:

vmd bin	for calculating risk ratio	for ATM compatibility
1	0.013	0.128
2	0.026	0.135
3	0.035	0.209
4	0.065	0.171
5	0.100	0.160
6	0.161	0.092
7	0.113	0.043
8	0.091	0.025
9	0.104	0.014
10	0.091	0.009

*Note.*— The weights for the *vmd* bins do not sum to 1.0. The weights specified are based on an analysis of encounters captured in ATC ground radar data. The missing proportion reflects the fact that the encounters captured included some with *vmd* exceeding the maximum *vmd* in the model.



4.4.2.6.2.4.3 For the crossing classes, the relative weights of the *vmd* bins shall be as follows:

<i>vmd bin</i>	<i>for calculating risk ratio</i>	<i>for ATM compatibility</i>
1	0	0.064
2	0.026	0.144
3	0.036	0.224
4	0.066	0.183
5	0.102	0.171
6	0.164	0.098
7	0.115	0.046
8	0.093	0.027
9	0.106	0.015
10	0.093	0.010

*Note.*— For the crossing classes, *vmd* must exceed 100 ft so that the encounter qualifies as a crossing encounter. Thus, for the calculation of risk ratio there is no *vmd* bin 1, and for calculations of the compatibility with ATM *vmd* bin 1 is limited to [100 ft, 200 ft].

#### 4.4.2.6.3 CHARACTERISTICS OF THE AIRCRAFT TRAJECTORIES IN THE VERTICAL PLANE

4.4.2.6.3.1 *vmd*. The *vmd* for each encounter shall be selected randomly from a distribution that is uniform in the interval covered by the appropriate *vmd* bin.

##### 4.4.2.6.3.2 Vertical rate

4.4.2.6.3.2.1 For each aircraft in each encounter, either the vertical rate shall be constant ( $\dot{z}$ ) or the vertical trajectory shall be constructed so that the vertical rate at  $tca - 35$  s is  $\dot{z}_1$  and the vertical rate at  $tca + 5$  s is  $\dot{z}_2$ . Each vertical rate,  $\dot{z}$ ,  $\dot{z}_1$  or  $\dot{z}_2$ , shall be determined by first selecting randomly an interval within which it lies and then selecting the precise value from a distribution that is uniform over the interval selected.

4.4.2.6.3.2.2 The intervals within which the vertical rates lie shall depend on whether the aircraft is level, i.e. marked “L” in 4.4.2.6.2.3.1, or transitioning, i.e. marked “T” in 4.4.2.6.2.3.1, and shall be as follows:

<i>L</i>	<i>T</i>
[240 ft/min, 400 ft/min]	[3200 ft/min, 6000 ft/min]
[80 ft/min, 240 ft/min]	[400 ft/min, 3200 ft/min]
[-80 ft/min, 80 ft/min]	[-400 ft/min, 400 ft/min]
[-240 ft/min, 80 ft/min]	[-3 200 ft/min, 400 ft/min]
[-400 ft/min, 240 ft/min]	[-6 000 ft/min, 3200 ft/min]

4.4.2.6.3.2.3 For aircraft that are level over the entire encounter window, the vertical rate  $\dot{z}$  shall be constant. The probabilities for the intervals within which  $\dot{z}$  lies shall be as follows:

$\dot{z}$ (ft/min)	<i>prob</i> ( $\dot{z}$ )
[240 ft/min, 400 ft/min]	0.0382
[80 ft/min, 240 ft/min]	0.0989
[80 ft/min, 80 ft/min]	0.7040
[-240 ft/min, 80 ft/min]	0.1198
[-400 ft/min, 240 ft/min]	0.0391

4.4.2.6.3.2.4 For aircraft that are not level over the entire encounter window, the intervals for  $\dot{z}_1$  and  $\dot{z}_2$  shall be determined jointly by random selection using joint probabilities that depend on altitude layer and on whether the aircraft is transitioning at the beginning of the encounter window (Rate-to-Level), at the end of the encounter window (Level-to-Rate) or at both the beginning and the end (Rate-to-Rate). The joint probabilities for the vertical rate intervals shall be as follows:

for aircraft with Rate-to-Level trajectories in layers 1 to 3,

$\dot{z}_2$ interval	joint probability of $\dot{z}_1$ and $\dot{z}_2$ interval					
[240 ft/min, 400 ft/min]	0.0019	0.0169	0.0131	0.1554	0.0000	
[80 ft/min, 240 ft/min]	0.0000	0.0187	0.0019	0.1086	0.0000	
[-80 ft/min, 80 ft/min]	0.0037	0.1684	0.0094	0.1124	0.0075	
[-240 ft/min, -80 ft/min]	0.0037	0.1461	0.0094	0.0243	0.0037	
[-400 ft/min, -240 ft/min]	0.0000	0.1742	0.0094	0.0094	0.0019	
	-6 000 ft/min	-3 200 ft/min	-400 ft/min	400 ft/min	3 200 ft/min	6 000 ft/min
						$\dot{z}_1$

for aircraft with Rate-to-Level trajectories in layers 4 to 6,

$\dot{z}_2$ interval	joint probability of $\dot{z}_1$ and $\dot{z}_2$ interval					
[240 ft/min, 400 ft/min]	0.0105	0.0035	0.0000	0.1010	0.0105	
[80 ft/min, 240 ft/min]	0.0035	0.0418	0.0035	0.1776	0.0279	
[-80 ft/min, 80 ft/min]	0.0279	0.1219	0.0000	0.2403	0.0139	
[-240 ft/min, -80 ft/min]	0.0035	0.0767	0.0000	0.0488	0.0105	
[-400 ft/min, -240 ft/min]	0.0105	0.0453	0.0035	0.0174	0.0000	
	-6 000 ft/min	-3 200 ft/min	-400 ft/min	400 ft/min	3 200 ft/min	6 000 ft/min
						$\dot{z}_1$

for aircraft with Level-to-Rate trajectories in layers 1 to 3,

$\dot{z}_2$ interval	joint probability of $\dot{z}_1$ and $\dot{z}_2$ interval					
[3 200 ft/min, 6000 ft/min]	0.0000	0.0000	0.0000	0.0000	0.0000	
[400 ft/min, 3200 ft/min]	0.0074	0.0273	0.0645	0.0720	0.1538	
[-400 ft/min, 400 ft/min]	0.0000	0.0000	0.0000	0.0000	0.0000	
[-3 200 ft/min, -400 ft/min]	0.2978	0.2084	0.1365	0.0273	0.005	
[-6 000ft/min, -3 200ft/min]	0.0000	0.0000	0.0000	0.0000	0.0000	
	-400 ft/min	-240 ft/min	-80 ft/min	80 ft/min	240 ft/min	400 ft/min
						$\dot{z}_1$

for aircraft with Level-to-Rate trajectories in layers 4 to 6,

$\dot{z}_2$ interval	joint probability of $\dot{z}_1$ and $\dot{z}_2$ interval					
[3 200 ft/min, 6 000 ft/min]	0.0000	0.0000	0.0000	0.0000	0.0192	
[400 ft/min, 3 200 ft/min]	0.0000	0.0000	0.0962	0.0577	0.1154	
[-400 ft/min, 400 ft/min]	0.0000	0.0000	0.0000	0.0000	0.0000	
[-3 200 ft/min, -400 ft/min]	0.1346	0.2692	0.2308	0.0577	0.0192	
[-6 000 ft/min, -3 200 ft/min]	0.0000	0.0000	0.0000	0.0000	0.0000	
	-400 ft/min	-240 ft/min	-80 ft/min	80 ft/min	240 ft/min	400 ft/min
						$\dot{z}_1$

for aircraft with Rate-to-Rate trajectories in layers 1 to 3,

$\dot{z}_2$  interval

	joint probability of $\dot{z}_1$ and $\dot{z}_2$ interval					
[3 200 ft/min, 6 000 ft/min]	0.0000	0.0000	0.0007	0.0095	0.0018	
[400 ft/min, 3 200 ft/min]	0.0000	0.0018	0.0249	0.2882	0.0066	
[-400 ft/min, 400 ft/min]	0.0000	0.0000	0.0000	0.0000	0.0000	
[-3 200 ft/min, -400 ft/min]	0.0048	0.5970	0.0600	0.0029	0.0011	
[-6 000 ft/min, -3 200 ft/min]	0.0000	0.0007	0.0000	0.0000	0.0000	
	-6 000 ft/min	-3 200 ft/min	-400 ft/min	400 ft/min	3 200 ft/min	6 000 ft/min
	$\dot{z}_1$					

for aircraft with Rate-to-Rate trajectories in layers 4 to 6,

$\dot{z}_2$  interval

	joint probability of $\dot{z}_1$ and $\dot{z}_2$ interval					
[3 200 ft/min, 6 000 ft/min]	0.0014	0.0000	0.0028	0.0110	0.0069	
[400 ft/min, 3 200 ft/min]	0.0028	0.0028	0.0179	0.4889	0.0523	
[-400 ft/min, 400 ft/min]	0.0000	0.0000	0.0000	0.0000	0	
[-3 200 ft/min, -400 ft/min]	0.0317	0.3029	0.0262	0.0152	0.0028	
[-6 000 ft/min, -3 200 ft/min]	0.0110	0.0220	0.0014	0.0000	0	
	-6 000 ft/min	-3 200 ft/min	-400 ft/min	400 ft/min	3 200 ft/min	6 000 ft/min
	$\dot{z}_1$					

4.4.2.6.3.2.5 For a Rate-to-Rate track, if line  $|\dot{z}_2 - \dot{z}_1| < 566$  ft/min then the track shall be constructed with a constant rate equal to  $\dot{z}_1$ .

#### 4.4.2.6.3.3 Vertical acceleration

4.4.2.6.3.3.1 Subject to 4.4.2.6.3.2.5, for aircraft that are not level over the entire encounter window, the rate shall be constant and equal to  $\dot{z}_1$  over at least the interval  $[tca - 40 \text{ s}, tca - 35 \text{ s}]$  at the beginning of the encounter window, and shall be constant and equal to  $\dot{z}_2$  over at least the interval  $[tca + 5 \text{ s}, tca + 10 \text{ s}]$  at the end of the encounter window. The vertical acceleration shall be constant in the intervening period.

4.4.2.6.3.3.2 The vertical acceleration ( $\ddot{z}$ ) shall be modelled as follows:

$$\ddot{z} = (A\dot{z}_2 - \dot{z}_1) + \varepsilon$$

where the parameter  $A$  is case-dependent as follows:

Case	$A(s^{-1})$	
	Layers 1-3	Layers 4-6
Rate-to-Level	0.071	0.059
Level-to-Rate	0.089	0.075
Rate-to-Rate	0.083	0.072

and the error  $\varepsilon$  is selected randomly using the following probability density:

$$p(\varepsilon) = \frac{1}{2\mu} \exp\left(-\frac{|\varepsilon|}{\mu}\right)$$

where  $\mu = 0.3 \text{ ft s}^{-2}$ .

*Note.*— The sign of the acceleration  $\ddot{z}$  is determined by  $\dot{z}_1$  and  $\dot{z}_2$ . An error  $\varepsilon$  that reverses this sign must be rejected and the error reselected.

4.4.2.6.3.4 *Acceleration start time.* The acceleration start time shall be distributed uniformly in the time interval [ $tca - 35 \text{ s}$ ,  $tca - 5 \text{ s}$ ] and shall be such that  $\dot{z}_2$  is achieved no later than  $tca + 5 \text{ s}$ .

#### 4.4.2.6.4 CHARACTERISTICS OF THE AIRCRAFT TRAJECTORIES IN THE HORIZONTAL PLANE

##### 4.4.2.6.4.1 Horizontal miss distance

4.4.2.6.4.1.1 For calculations of the effect of ACAS on the risk of collision (4.4.3), *hmd* shall be uniformly distributed in the range [0, 500 ft].

4.4.2.6.4.1.2 For calculations concerning the compatibility of ACAS with ATM (4.4.4), *hmd* shall be distributed so that the values of *hmd* have the following cumulative probabilities:

hmd (ft)	cumulative probability		hmd (ft)	cumulative probability	
	Layers 1-3	Layers 4-6		Layers 1-3	Layers 4-6
0	0.000	0.000	17013	0.999	0.868
1215	0.152	0.125	18228	1.000	0.897
2430	0.306	0.195	19443		0.916
3646	0.482	0.260	20659		0.927
4860	0.631	0.322	21874		0.939
6076	0.754	0.398	23089		0.946
7921	0.859	0.469	24304		0.952
8506	0.919	0.558	25520		0.965
9722	0.954	0.624	26735		0.983
10937	0.972	0.692	27950		0.993
12152	0.982	0.753	29165		0.996
13367	0.993	0.801	30381		0.999
14582	0.998	0.821	31596		1.000
15798	0.999	0.848			

4.4.2.6.4.2 *Approach angle.* The cumulative distribution for the horizontal approach angle shall be as follows:

approach angle (deg.)	cumulative probability		approach angle (deg.)	cumulative probability	
	Layers 1-3	Layers 4-6		Layers 1-3	Layers 4-6
0	0.00	0.00	100	0.38	0.28
10	0.14	0.05	110	0.43	0.31
20	0.17	0.06	120	0.49	0.35
30	0.18	0.08	130	0.55	0.43
40	0.19	0.08	140	0.62	0.50
50	0.21	0.10	150	0.71	0.59

approach angle (deg.)	cumulative probability		approach angle (deg.)	cumulative probability	
	Layers 1-3	Layers 4-6		Layers 1-3	Layers 4-6
60	0.23	0.13	160	0.79	0.66
70	0.25	0.14	170	0.88	0.79
80	0.28	0.19	180	1.00	1.00
90	0.32	0.22			

4.4.2.6.4.3 *Aircraft speed.* The cumulative distribution for each aircraft's horizontal ground speed at closest approach shall be as follows:

ground speed (kt)	cumulative probability		ground speed (kt)	cumulative probability	
	Layers 1-3	Layers 4-6		Layers 1-3	Layers 4-6
45	0.000		325	0.977	0.528
50	0.005		350	0.988	0.602
75	0.024	0.000	375	0.997	0.692
100	0.139	0.005	400	0.998	0.813
125	0.314	0.034	425	0.999	0.883
150	0.486	0.064	450	1.000	0.940
175	0.616	0.116	475		0.972
200	0.700	0.171	500		0.987
225	0.758	0.211	525		0.993
250	0.821	0.294	550		0.998
275	0.895	0.361	575		0.999
300	0.949	0.427	600		1.000

4.4.2.6.4.4 *Horizontal manoeuvre probabilities.* For each aircraft in each encounter, the probability of a turn, the probability of a speed change given a turn, and the probability of a speed change given no turn shall be as follows:

Layer	Prob(turn)	Prob(speed change) given a turn	Prob(speed change) given no turn
1	0.31	0.20	0.5
2	0.29	0.20	0.25
3	0.22	0.10	0.15
4, 5, 6	0.16	0.05	0.10

4.4.2.6.4.4.1 Given a speed change, the probability of a speed increase shall be 0.5 and the probability of a speed decrease shall be 0.5.

4.4.2.6.4.5 *Turn extent.* The cumulative distribution for the extent of any turn shall be as follows:

Turn extent (deg.)	cumulative probability	
	Layers 1-3	Layers 4-6
15	0.00	0.00
30	0.43	0.58
60	0.75	0.90
90	0.88	0.97
120	0.95	0.99
150	0.98	1.00
180	0.99	
210	1.00	

4.4.2.6.4.5.1 The direction of the turn shall be random, with the probability of a left turn being 0.5 and the probability of a right turn being 0.5.

4.4.2.6.4.6 *Bank angle.* An aircraft's bank angle during a turn shall not be less than 15 degrees. The probability that it equals 15 degrees shall be 0.79 in layers 1-3 and 0.54 in layers 4-5. The cumulative distribution for larger bank angles shall be as follows:

<i>Bank angle (deg.)</i>	<i>cumulative probability</i>	
	<i>Layers 1-3</i>	<i>Layers 4-6</i>
15	0.79	0.54
25	0.96	0.82
35	0.99	0.98
50	1.00	1.00

4.4.2.6.4.7 *Turn end time.* The cumulative distribution for each aircraft's turn end time shall be as follows:

<i>Turn end time (seconds before tca)</i>	<i>cumulative probability</i>	
	<i>Layers 1-3</i>	<i>Layers 4-6</i>
0	0.42	0.28
5	0.64	0.65
10	0.77	0.76
15	0.86	0.85
20	0.92	0.94
25	0.98	0.99
30	1.00	1.00

4.4.2.6.4.8 *Speed change.* A constant acceleration or deceleration shall be randomly selected for each aircraft performing a speed change in a given encounter, and shall be applied for the duration of the encounter. Accelerations shall be uniformly distributed between 2 kt/s and 6 kt/s. Decelerations shall be uniformly distributed between 1 kt/s and 3 kt/s.

#### 4.4.2.7 ACAS EQUIPAGE OF THE INTRUDER

The performance requirements specified in 4.4.3 and 4.4.4 each apply to three distinct situations in which the following conditions concerning the intruder's ACAS and trajectory shall apply:

- a) where the intruder involved in each encounter is not equipped (4.4.2.1 j) 1)), it follows a trajectory identical to that which it follows when own aircraft is not equipped;
- b) where the intruder is ACAS-equipped but follows a trajectory identical to that in the unequipped encounter (4.4.2.1 j) 2)):
  - 1) it follows the identical trajectory regardless of whether or not there is an RA;
  - 2) the intruder ACAS generates an RA and transmits an RAC that is received immediately after any RA is first announced to the pilot of own aircraft;
  - 3) the sense of the RAC generated by the intruder ACAS and transmitted to own aircraft is opposite to the sense of the first RAC selected and transmitted to the intruder by own aircraft (4.3.6.1.3);
  - 4) the RAC transmitted by the intruder is received by own aircraft; and

- 5) the requirements apply both when own aircraft has the lower aircraft address and when the intruder aircraft has the lower aircraft address; and
- c) where the intruder is equipped with an ACAS having a collision avoidance logic identical to that of own ACAS (4.4.2.1 j) 3)):
  - 1) the conditions relating to the performance of own aircraft, ACAS and pilot apply equally to the intruder aircraft, ACAS and pilot;
  - 2) RACs transmitted by one aircraft are received by the other; and
  - 3) the requirements apply both when own aircraft has the lower aircraft address and when the intruder aircraft has the lower aircraft address.

#### 4.4.2.8 COMPATIBILITY BETWEEN DIFFERENT COLLISION AVOIDANCE LOGIC DESIGNS

**Recommendation.**— *When considering alternative collision avoidance logic designs, certification authorities should verify that:*

- a) *the performances of the alternative design are acceptable in encounters involving ACAS units that use existing designs; and*
- b) *the performances of the existing designs are not degraded by the use of the alternative design.*

*Note.*— *To address the compatibility between different collision avoidance logic designs, the conditions described in 4.4.2.7 b) are the most severe that can be anticipated in this respect.*

### 4.4.3 Reduction in the risk of collision

Under the conditions of 4.4.2, the collision avoidance logic shall be such that the expected number of collisions is reduced to the following proportions of the number expected in the absence of ACAS:

- a) when the intruder is not ACAS equipped 0.18;
- b) when the intruder is equipped but does not respond 0.32; and
- c) when the intruder is equipped and responds 0.04.

### 4.4.4 Compatibility with air traffic management (ATM)

#### 4.4.4.1 NUISANCE ALERT RATE

4.4.4.1.1 Under the conditions of 4.4.2, the collision avoidance logic shall be such that the proportion of RAs which are a “nuisance” (4.4.4.1.2) shall not exceed:

- .06 when own aircraft’s vertical rate at the time the RA is first issued is less than 400 ft/min; or
- .08 when own aircraft’s vertical rate at the time the RA is first issued exceeds 400 ft/min.

*Note.*— This requirement is not qualified by the ACAS equipage of the intruder (4.4.2.7) since it has negligible effect on the occurrence and frequency of nuisance RAs.

4.4.4.1.2 An RA shall be considered a “nuisance” for the purposes of 4.4.4.1.1 unless, at some point in the encounter in the absence of ACAS, the horizontal separation and the vertical separation are simultaneously less than the following values:

	<i>horizontal separation</i>	<i>vertical separation</i>
<i>above FL100</i>	2.0 NM	750 ft
<i>below FL100</i>	1.2 NM	750 ft

#### 4.4.4.2 COMPATIBLE SENSE SELECTION

Under the conditions of 4.4.2, the collision avoidance logic shall be such that the proportion of encounters in which following the RA results in an altitude separation at closest approach with the opposite sign to that occurring in the absence of ACAS shall not exceed the following values:

- a) when the intruder is not ACAS equipped 0.08;
- b) when the intruder is equipped but does not respond 0.08; and
- c) when the intruder is equipped and responds 0.12.

#### 4.4.4.3 DEVIATIONS CAUSED BY ACAS

4.4.4.3.1 Under the conditions of 4.4.2, the collision avoidance logic shall be such that the number of RAs resulting in “deviations” (4.4.4.3.2) greater than the values indicated shall not exceed the following proportions of the total number of RAs:

	<i>when own aircraft’s vertical rate at the time the RA is first issued</i>	
	<i>is less than 400ft/min</i>	<i>exceeds 400ft/min</i>
<i>when the intruder is not ACAS equipped, for deviations <math>\geq 300</math> ft</i>	0.15	0.23
<i>for deviations <math>\geq 600</math> ft</i>	0.04	0.13
<i>for deviations <math>\geq 1\ 000</math> ft</i>	0.01	0.07
<i>when the intruder is equipped but does not respond, for deviations <math>\geq 300</math> ft</i>	0.23	0.35
<i>for deviations <math>\geq 600</math> ft</i>	0.06	0.16
<i>for deviations <math>\geq 1\ 000</math> ft</i>	0.02	0.07
<i>when the intruder is equipped and responds, for deviations <math>\geq 300</math> ft</i>	0.11	0.23
<i>for deviations <math>\geq 600</math> ft</i>	0.02	0.12
<i>for deviations <math>\geq 1\ 000</math> ft</i>	0.01	0.06

4.4.4.3.2 For the purposes of 4.4.4.3.1, the “deviation” of the equipped aircraft from the original trajectory shall be measured in the interval from the time at which the RA is first issued until the time at which, following cancellation of the RA, the equipped aircraft has recovered its original altitude rate. The deviation shall be calculated as the largest altitude difference at any time in this interval between the trajectory followed by the equipped aircraft when responding to its RA and its original trajectory.



#### 4.4.5 Relative value of conflicting objectives

**Recommendation.**— *The collision avoidance logic should be such as to reduce as much as practicable the risk of collision (measured as defined in 4.4.3) and limit as much as practicable the disruption to ATM (measured as defined in 4.4.4).*

### 4.5 ACAS USE OF EXTENDED SQUITTER

#### 4.5.1 ACAS hybrid surveillance using extended squitter position data

*Note.*— *Hybrid surveillance is the technique used by ACAS to take advantage of passive position information available via extended squitter DF = 17. Using hybrid surveillance, ACAS validates the position provided by extended squitter through direct active range measurement. An initial validation is performed at track initiation. Revalidation is performed once every 60 seconds for targets that do not meet the conditions in altitude or range. Revalidation is performed once per 10 seconds if the intruder becomes a near threat in altitude or range. Finally, regular active surveillance is performed once per second on intruders that become a near threat in both altitude and range. In this manner, passive surveillance (once validated) is used for non-threatening intruders thus lowering the ACAS interrogation rate. Active surveillance is used whenever an intruder becomes a near threat in order to preserve ACAS independence as an independent safety monitor.*

##### 4.5.1.1 DEFINITIONS

**Active surveillance.** The process of tracking an intruder by using the information gained from the replies to own ACAS interrogations.

**Hybrid surveillance.** The process of using active surveillance to validate and monitor other aircraft being tracked principally using passive surveillance in order to preserve ACAS independence.

**Initial acquisition.** The process of starting the formation of a new track upon receipt of a squitter from a Mode S aircraft for which there is no track by making an active interrogation.

**Passive surveillance.** The process of tracking another aircraft without interrogating it, by using the other aircraft's extended squitters. ACAS uses the information obtained to monitor the need for active surveillance, but not for any other purpose.

**Validation.** The process of verifying the relative position of an intruder using passive information by comparing it to the relative position obtained by active interrogation.

4.5.1.2 An ACAS equipped to receive extended squitter airborne position messages for passive surveillance of non-threatening intruders shall utilize this passive position information in the following manner.

##### 4.5.1.3 PASSIVE SURVEILLANCE

4.5.1.3.1 **Validation.** To validate the position of an intruder reported by extended squitter, ACAS shall determine the relative range and relative bearing as computed from the position and geographical heading of own aircraft and the intruder's position as reported in the extended squitter. This derived range and relative bearing and the altitude reported in the squitter shall be compared to the range, relative bearing and altitude determined by active ACAS interrogation of the aircraft. Differences between the derived and measured range and relative bearing and the squitter and reply altitude shall be computed and used in tests to determine whether the extended squitter data is valid. If these tests are satisfied the passive position shall be considered to be validated and the track shall be maintained on passive data unless it is a near threat as described in 4.5.1.4. If any of these validation tests fail, active surveillance shall be used to track the intruder.

*Note.*— Suitable tests for validating extended squitter data information for the purposes of ACAS hybrid surveillance can be found in RTCA/DO-300.

4.5.1.3.2 *Supplementary active interrogations.* In order to ensure that an intruder's track is updated at least as frequently as required in the absence of extended squitter data (4.3.7.1.2.2), each time a track is updated using squitter information the time at which an active interrogation would next be required shall be calculated. An active interrogation shall be made at that time if a further squitter has not been received before the interrogation is due.

4.5.1.4 *Near threat.* An intruder shall be tracked under active surveillance if it is a near threat, as determined by separate tests on the range and altitude of the aircraft. These tests shall be such that an intruder is considered a near threat before it becomes a potential threat, and thus triggers a traffic advisory as described in 4.3.3. These tests shall be performed once per second. All near threats, potential threats and threats shall be tracked using active surveillance.

*Note.*— Suitable tests for determining that an intruder is a near threat can be found in RTCA/DO-300.

4.5.1.5 *Revalidation and monitoring.* If an aircraft is being tracked using passive surveillance, periodic active interrogations shall be performed to validate and monitor the extended squitter data as required in 4.5.1.3.1. The default rates of revalidation shall be once per minute for a non-threat and once per 10 seconds for a near threat. The tests required in 4.5.1.3.1 shall be performed for each interrogation, and active surveillance shall be used to track the intruder if these revalidation tests fail.

4.5.1.6 *Full active surveillance.* If the following condition is met for a track being updated via passive surveillance data:

- a)  $|a| \leq 10\,000$  ft and both;
- b)  $|a| \leq 3\,000$  ft or  $|a - 3\,000| / |\dot{a}| \leq 60$  s; and
- c)  $r \leq 3$  NM or  $(r - 3\text{ NM}) / |\dot{r}| \leq 60$  s;

where:  $a$  = intruder altitude separation in ft  
 $\dot{a}$  = altitude rate estimate in ft/s  
 $r$  = intruder slant range in NM  
 $\dot{r}$  = range rate estimate in NM/s

the aircraft shall be declared an active track and shall be updated on active range measurements once per second for as long as the above condition is met.

4.5.1.6.1 All near threats, potential threats and threats shall be tracked using active surveillance.

4.5.1.6.2 A track under active surveillance shall transition to passive surveillance if it is neither a near, potential threat nor a threat. The tests used to determine it is no longer a near threat shall be similar to those used in 4.5.1.4 but with larger thresholds in order to have hysteresis which prevents the possibility of frequent transitions between active and passive surveillance.

*Note.*— Suitable tests for determining that an intruder is no longer a near threat can be found in RTCA/DO-300.

#### 4.5.2 ACAS operation with an improved receiver MTL

*Note.*— Applications of extended squitter that are independent of ACAS might be implemented (for convenience) using the ACAS receiver. The use of an improved receiver minimum triggering level (MTL) will make it possible to receive extended squitters from ranges of up to 60 NM and beyond in support of such applications.

4.5.2.1 An ACAS operating with a receiver having a MTL more sensitive than  $-74$  dBm shall implement the capabilities specified in the following paragraphs.

4.5.2.2 *Dual minimum triggering levels.* The ACAS receiver shall be capable of setting an indication for each squitter reception as to whether the reply would have been detected by an ACAS operating with a conventional MTL ( $-74$  dBm). Squitter receptions received at the conventional MTL shall be passed to the ACAS surveillance function for further processing. Squitter receptions that do not meet this condition shall not be passed to the ACAS surveillance function.

*Note 1.— Extended squitters containing position report information will be disseminated for display in connection with an extended squitter application.*

*Note 2.— Use of the conventional MTL for the ACAS surveillance function preserves the current operation of ACAS surveillance when operating with a receiver with an improved MTL.*

4.5.2.3 *Dual or re-triggerable reply processor.* The ACAS Mode S reply processing function shall:

- a) use separate reply processors for Mode S reply formats received at or above the conventional MTL and a separate reply processor for Mode S reply formats received below the conventional MTL; or,
- b) use a Mode S reply processor that will re-trigger if it detects a Mode S preamble that is 2 to 3 dB stronger than the reply that is currently being processed.

*Note.— Care must be taken to ensure that low-level squitters (i.e. those below the conventional MTL) do not interfere with the processing of acquisition squitters for ACAS. This could happen if the low-level squitter is allowed to capture the reply processor. This can be prevented by using a separate reply processor for each function, or by requiring the reply processor to be re-triggered by a higher level squitter.*



## CHAPTER 5. MODE S EXTENDED SQUITTER

*Note 1.— A functional model of Mode S extended squitter systems supporting ADS-B and/or TIS-B is depicted in Figure 5-1.*

*Note 2.— Airborne systems transmit ADS-B messages (ADS-B OUT) and may also receive ADS-B and TIS-B messages (ADS-B IN and TIS-B IN). Ground systems (i.e. ground stations) transmit TIS-B (as an option) and receive ADS-B messages.*

*Note 3.— Although not explicitly depicted in the functional model presented in Figure 5-1, extended squitter systems installed on aerodrome surface vehicles or fixed obstacles may transmit ADS-B messages (ADS-B OUT).*

### 5.1 MODE S EXTENDED SQUITTER TRANSMITTING SYSTEM CHARACTERISTICS

*Note.— Many of the requirements associated with the transmission of Mode S extended squitter are included in Chapter 2 and Chapter 3 for Mode S transponder and non-transponder devices using the message formats defined in the Technical Provisions for Mode S Services and Extended Squitter (Doc 9871). The provisions presented within the following subsections are focused on requirements applicable to specific classes of airborne and ground transmitting systems that are supporting the applications of ADS-B and TIS-B.*

#### 5.1.1 ADS-B out requirements

5.1.1.1 Aircraft, surface vehicles and fixed obstacles supporting an ADS-B capability shall incorporate the ADS-B message generation function and the ADS-B message exchange function (transmit) as depicted in Figure 5-1.

5.1.1.1.1 ADS-B transmissions from aircraft shall include position, aircraft identification and type, airborne velocity, and event driven messages including emergency/priority information.

*Note.— The data formats and protocols for messages transferred via extended squitter are specified in the Technical Provisions for Mode S Services and Extended Squitter (Doc 9871).*

5.1.1.2 *Extended squitter ADS-B transmission requirements.* Mode S extended squitter transmitting equipment shall be classified according to the unit's range capability and the set of parameters that it is capable of transmitting consistent with the following definition of general equipment classes and the specific equipment classes defined in Tables 5-1 and 5-2:

- a) Class A extended squitter airborne systems support an interactive capability incorporating both an extended squitter transmission capability (i.e. ADS-B OUT) with a complementary extended squitter reception capability (i.e. ADS-B IN) in support of onboard ADS-B applications;
- b) Class B extended squitter systems provide a transmission only (i.e. ADS-B OUT without an extended squitter reception capability) for use on aircraft, surface vehicles, or fixed obstructions; and
- c) Class C extended squitter systems have only a reception capability and thus have no transmission requirements.

5.1.1.3 *Class A extended squitter system requirements.* Class A extended squitter airborne systems shall have transmitting and receiving subsystem characteristics of the same class (i.e. A0, A1, A2, or A3) as specified in 5.1.1.1 and 5.2.1.2.

*Note.*— Class A transmitting and receiving subsystems of the same specific class (e.g. Class A2) are designed to complement each other with their functional and performance capabilities. The minimum air-to-air range that extended squitter transmitting and receiving systems of the same class are designed to support are:

- a) A0-to-A0 nominal air-to-air range is 10 NM;
- b) A1-to-A1 nominal air-to-air range is 20 NM;
- c) A2-to-A2 nominal air-to-air range is 40 NM; and
- d) A3-to-A3 nominal air-to-air range is 90 NM.

*The above ranges are design objectives and the actual effective air-to-air range of the Class A extended squitter systems may be larger in some cases (e.g. in environments with low levels of 1 090 MHz fruit) and shorter in other cases (e.g. in environments with very high levels of 1 090 MHz fruit).*

## 5.1.2 TIS-B out requirements

5.1.2.1 Ground stations supporting a TIS-B capability shall incorporate the TIS-B message generation function and the TIS-B message exchange function (transmit).

5.1.2.2 The extended squitter messages for TIS-B shall be transmitted by an extended squitter ground station when connected to an appropriate source of surveillance data.

*Note 1.*— *Extended squitter messages for TIS-B are specified in the Technical Provisions for Mode S Services and Extended Squitter (Doc 9871).*

*Note 2.*— *Ground stations supporting TIS-B use an extended squitter transmission capability. The characteristics of such ground stations, in terms of transmitter power, antenna gain, transmission rates, etc., are to be tailored to the desired TIS-B service volume of the specific ground station assuming airborne users are equipped with (at least) Class A1 receiving systems.*

5.1.2.3 **Recommendation.**— *The maximum transmission rates and effective radiated power of the transmissions should be controlled to avoid unacceptable levels of RF interference to other 1 090 MHz systems (i.e. SSR and ACAS).*

## 5.2 MODE S EXTENDED SQUITTER RECEIVING SYSTEM CHARACTERISTICS (ADS-B IN AND TIS-B IN)

*Note 1.*— *The paragraphs herein describe the required capabilities for 1 090 MHz receivers used for the reception of Mode S extended squitter transmissions that convey ADS-B and/or TIS-B messages. Airborne receiving systems support ADS-B and TIS-B reception while ground receiving systems support only ADS-B reception.*

*Note 2.*— *Detailed technical provisions for Mode S extended squitter receivers can be found within RTCA DO-260A, “Minimum Operational Performance Standards for 1 090 MHz Extended Squitter Automatic Dependent Surveillance – Broadcast (ADS-B) and Traffic Information Services – Broadcast (TIS-B).”*

### 5.2.1 Mode S extended squitter receiving system functional requirements

5.2.1.1 Mode S extended squitter receiving systems shall perform the message exchange function (receive) and the report assembler function.

*Note.— The extended squitter receiving system receives ADS-B Mode S extended squitter messages and outputs ADS-B reports to client applications. Airborne receiving systems also receive TIS-B extended squitter messages and output TIS-B reports to client applications. This functional model (shown in Figure 5-1) depicts both airborne and ground 1 090 MHz ADS-B receiving systems.*

5.2.1.2 *Mode S extended squitter receiver classes.* The required functionality and performance characteristics for the Mode S extended squitter receiving system will vary depending on the ADS-B and TIS-B client applications to be supported and the operational use of the system. Airborne Mode S extended squitter receivers shall be consistent with the definition of receiving system classes shown in Table 5-3.

*Note.— Different equipment classes of Mode S extended squitter installations are possible. The characteristics of the receiver associated with a given equipment class are intended to be appropriate to support the required level of operational capability. Equipment classes A0 through A3 are applicable to those Mode S extended airborne installations that include a Mode S extended squitter transmission (ADS-OUT) and reception (ADS-B IN) capability. Equipment classes B0 through B3 are applicable to Mode S extended installations with only a transmission (ADS-B OUT) capability and includes equipment classes applicable to airborne, surface vehicles and fixed obstructions. Equipment classes C1 through C3 are applicable to Mode S extended squitter ground receiving systems. Guidance on the Mode S extended squitter equipment classes is provided in the Manual on the Secondary Surveillance Radar (SSR) Systems (Doc 9684).*

### 5.2.2 Message exchange function

5.2.2.1 The message exchange function shall include the 1 090 MHz receiving antenna and the radio equipment (receiver/demodulator/decoder/data buffer) sub-functions.

5.2.2.2 *Message exchange functional characteristics.* The airborne Mode S extended squitter receiving system shall support the reception and decoding of all extended squitter messages as listed in Table 5-3. The ground ADS-B extended squitter receiving system shall, as a minimum, support the reception and decoding of all of the extended squitter message types that convey information needed to support the generation of the ADS-B reports of the types required by the client ATM ground applications.

5.2.2.3 *Required message reception performance.* The airborne Mode S extended squitter receiver/demodulation/decoder shall employ the reception techniques and have a receiver minimum trigger threshold level (MTL) as listed in Table 5-3 as a function of the airborne receiver class. The reception technique and MTL for extended squitter ground receiver shall be selected to provide the reception performance (i.e. range and update rates) as required by the client ATM ground applications.

5.2.2.4 *Enhanced reception techniques.* Class A1, A2 and A3 airborne receiving systems shall include the following features to provide improved probability of Mode S extended squitter reception in the presence of multiple overlapping Mode A/C fruit and/or in the presence of an overlapping stronger Mode S fruit, as compared to the performance of the standard reception technique required for Class A0 airborne receiving systems:

- a) Improved Mode S extended squitter preamble detection.
- b) Enhanced error detection and correction.
- c) Enhanced bit and confidence declaration techniques applied to the airborne receiver classes as shown below:

- 1) Class A1 – Performance equivalent to or better than the use of the “Centre Amplitude” technique.
- 2) Class A2 – Performance equivalent to or better than the use of the “Multiple Amplitude Samples” baseline technique, where at least 8 samples are taken for each Mode S bit position and are used in the decision process.
- 3) Class A3 – Performance equivalent to or better than the use of the “Multiple Amplitude Samples” baseline technique, where at least 10 samples are taken for each Mode S bit position and are used in the decision process.

*Note 1.— The above enhanced reception techniques are as defined in RTCA DO-260A, Appendix I.*

*Note 2.— The performance provided for each of the above enhanced reception techniques when used in a high fruit environment (i.e. with multiple overlapping Mode A/C fruit) is expected to be at least equivalent to that provided by the use of the techniques described in RTCA DO-260A, Appendix I.*

*Note 3.— It is considered appropriate for ground extended squitter receiving systems to employ the enhanced reception techniques equivalent to those specified for airborne Class A2 or A3 receiving systems.*

### 5.2.3 Report assembler function

5.2.3.1 The report assembler function shall include the message decoding, report assembly, and output interface sub-functions.

5.2.3.2 When an extended squitter message is received, the message shall be decoded and the applicable ADS-B report(s) of the types defined in 5.2.3.3 shall be generated within 0.5 seconds.

*Note 1.— Two configurations of extended squitter airborne receiving systems, which include the reception portion of the ADS-B message exchange function and the ADS-B/TIS-B report assembly function, are allowed:*

- a) *Type I extended squitter receiving systems receive ADS-B and TIS-B messages and produce application-specific subsets of ADS-B and TIS-B reports. Type I extended squitter receiving systems are customized to the particular client applications using ADS-B and TIS-B reports. Type I extended squitter receiving systems may additionally be controlled by an external entity to produce installation-defined subsets of the reports that those systems are capable of producing.*
- b) *Type II extended squitter receiving systems receive ADS-B and TIS-B messages and are capable of producing complete ADS-B and TIS-B reports in accordance with the equipment class. Type II extended squitter receiving systems may be controlled by an external entity to produce installation-defined subsets of the reports that those systems are capable of producing.*

*Note 2.— Extended squitter ground receiving systems receive ADS-B messages and produce either application-specific subsets or complete ADS-B reports based on the needs of the ground service provider, including the client applications to be supported.*

*Note 3.— The extended squitter message reception function may be physically partitioned into hardware separate from those that implement the report assembly function.*

#### 5.2.3.3 ADS-B REPORT TYPES

*Note 1.— The ADS-B report refers to the restructuring of ADS-B message data received from Mode S extended squitter broadcasts into various reports that can be used directly by a set of client applications. Five ADS-B report types are defined by the following subparagraphs for output to client applications. Additional information on the ADS-B report contents and the*



applicable mapping from extended squitter messages to ADS-B reports can be found in the Manual on the Secondary Surveillance Radar (SSR) Systems (Doc 9684) and RTCA DO-260A.

*Note 2.— The use of precision (e.g. GNSS UTC measured time) versus non-precision (e.g. internal receiving system clock) time sources as the basis for the reported time of applicability is described in 5.2.3.5.*

5.2.3.3.1 *State vector report.* The state vector report shall contain time of applicability, information about an airborne or vehicle's current kinematic state (e.g. position, velocity), as well as a measure of the integrity of the navigation data, based on information received in airborne or ground position, airborne velocity, and identification and type extended squitter messages. Since separate messages are used for position and velocity, the time of applicability shall be reported individually for the position related report parameters and the velocity related report parameters. Also, the state vector report shall include a time of applicability for the estimated position and/or estimated velocity information (i.e. not based on a message with updated position or velocity information) when such estimated position and/or velocity information is included in the state vector report.

*Note.— Specific requirements for the customization of this type of report may vary according to the needs of the client applications of each participant (ground or airborne). The state vector data is the most dynamic of the four ADS-B reports; hence, the applications require frequent updates of the state vector to meet the required accuracy for the operational dynamics of the typical airborne or ground operations of airborne and surface vehicles.*

5.2.3.3.2 *Mode status report.* The mode status report shall contain time of applicability and current operational information about the transmitting participant, including airborne/vehicle address, call sign, ADS-B version number, airborne/vehicle length and width information, state vector quality information, and other information based on information received in operational status, airborne identification and type, airborne velocity and airborne status extended squitter messages. Each time that a mode status report is generated, the report assembler function shall update the report time of applicability. Parameters for which valid data is not available shall either be indicated as invalid or omitted from the mode status report.

*Note 1.— Specific requirements for the customization of this type of report may vary according to the needs of the client applications of each participant (ground or airborne).*

*Note 2.— Once the target state and status message (as shown in the Manual on Mode S Specific Services (Doc 9688)) becomes available, certain parameters conveyed in that message type are also to be included in the mode status reports.*

*Note 3.— The age of the information being reported within the various data elements of a mode status report may vary as a result of the information having been received within different extended squitter messages at different times. Data being reported beyond the useful life of that parameter type may be either indicated as invalid or omitted from the mode status report as described in the Manual on the Secondary Surveillance Radar (SSR) Systems (Doc 9684).*

5.2.3.3.3 *Air referenced velocity report.* Air referenced velocity reports shall be generated when air referenced velocity information is received in airborne velocity extended squitter messages. The air referenced velocity report shall contain time of applicability, airspeed and heading information. Only certain classes of extended squitter receiving systems, as defined in 5.2.3.5, are required to generate air referenced velocity reports. Each time that an individual mode status report is generated, the report assembly function shall update the report time of applicability.

*Note 1.— The air referenced velocity report contains velocity information that is received in airborne velocity messages along with additional information received in airborne identification and type extended squitter messages. Air referenced velocity reports are not generated when ground referenced velocity information is being received in the airborne velocity extended squitter messages. Guidance on the air referenced velocity report contents is provided in the Manual on the Secondary Surveillance Radar (SSR) Systems (Doc 9684).*

*Note 2.— Specific requirements for the customization of this type of report may vary according to the needs of the client applications of each participant (ground or airborne).*

5.2.3.3.4 *Resolution advisory (RA) report.* The RA report shall contain time of applicability and the contents of an active ACAS resolution advisory (RA) as received in a Type=28 and Subtype=2 extended squitter message.

*Note.*— The RA report is only intended to be generated by ground receiving subsystems when supporting a ground ADS-B client application(s) requiring active RA information. An RA report will nominally be generated each time a Type=28, Subtype=2 extended squitter message is received.

#### 5.2.3.3.5 TARGET STATE REPORT

*Note.*— The requirements for reporting of target state information is not at the same level of maturity as for the other ADS-B report types. The reporting of target state information is currently not required, but may in the future be required for Class A2 and A3 airborne receiving systems. Once supported, the target state report will be generated when information is received in target state and status messages, along with additional information received in airborne identification and type extended squitter messages. The target state and status message is defined in the Manual on Mode S Specific Services (Doc 9688). Specific requirements for the customization of this type of report may vary according to the needs of the client applications of each participant (ground or airborne). Guidance on the target state report contents is provided in the Manual on Mode S Specific Services (Doc 9688).

### 5.2.3.4 TIS-B REPORT TYPES

5.2.3.4.1 As TIS-B messages are received by airborne receiving systems, the information shall be reported to client applications. Each time that an individual TIS-B report is generated, the report assembly function shall update the report time of applicability to the current time.

*Note 1.*— The TIS-B message formats are defined in the Technical Provisions for Mode S Services and Extended Squitter (Doc 9871).

*Note 2.*— The TIS-B report refers to the restructuring of TIS-B message data received from ground Mode S extended squitter broadcasts into reports that can be used by a set of client applications. Two ADS-B report types are defined by the following subparagraphs for output to client applications. Additional information on the TIS-B report contents and the applicable mapping from extended squitter messages to ADS-B reports can be found in the Manual on the Secondary Surveillance Radar (SSR) Systems (Doc 9684).

*Note 3.*— The use of precision (e.g. GNSS UTC measured time) versus non-precision (e.g. internal receiving system clock) time sources as the basis for the reported time of applicability is described in 5.2.3.5.

5.2.3.4.2 *TIS-B target report.* All received information elements, other than position, shall be reported directly, including all reserved fields for the TIS-B fine format messages and the entire message content of any received TIS-B management message. The reporting format is not specified in detail, except that the information content reported shall be the same as the information content received.

5.2.3.4.3 When a TIS-B position message is received, it is compared with tracks to determine whether it can be decoded into target position (i.e. correlated to an existing track). If the message is decoded into target position, a report shall be generated within 0.5 seconds. The report shall contain the received position information with a time of applicability, the most recently received velocity measurement with a time of applicability, the estimated position and velocity applicable to a common time of applicability, airborne/vehicle address, and all other information in the received message. The estimated values shall be based on the received position information and the track history of the target.

5.2.3.4.4 When a TIS-B velocity message is received, if it is correlated to a complete track, a report shall be generated, within 0.5 seconds of the message reception. The report shall contain the received velocity information with a time of applicability, the estimated position and velocity applicable to a common time of applicability, airborne/vehicle address, and all other information in the received message. The estimated values shall be based on the received ground reference velocity information and the track history of the target.

5.2.3.4.5 *TIS-B management report.* The entire message content of any received TIS-B management message shall be reported directly to the client applications. The information content reported shall be the same as the information content received.

5.2.3.4.5.1 The contents of any received TIS-B management message shall be reported bit-for-bit to the client applications.

*Note.*— *The processing of TIS-B management messages is defined in the Technical Provisions for Mode S Services and Extended Squitter (Doc 9871).*

#### 5.2.3.5 REPORT TIME OF APPLICABILITY

The receiving system shall use a local source of reference time as the basis for reporting the time of applicability, as defined for each specific ADS-B and TIS-B report type (see 5.2.3.3 and 5.2.3.4).

5.2.3.5.1 *Precision time reference.* Receiving systems intended to generate ADS-B and/or TIS-B reports based on the reception of surface position messages, airborne position messages, and/or TIS-B messages shall use GNSS UTC measured time for the purpose of generating the report time applicability for the following cases of received messages:

- a) version zero (0) ADS-B messages, as defined in 3.1.2.8.6.2, when the navigation uncertainty category (NUC) is 8 or 9;  
or
- b) version one (1) ADS-B or TIS-B messages, as defined in 3.1.2.8.6.2 and 3.1.2.8.7 respectively, when the navigation integrity category (NIC) is 10 or 11;

UTC measured time data shall have a minimum range of 300 seconds and a resolution of 0.0078125 (1/128) seconds.

#### 5.2.3.5.2 NON-PRECISION LOCAL TIME REFERENCE

5.2.3.5.2.1 For receiving systems not intended to generate ADS-B and/or TIS-B reports based on reception of ADS-B or TIS-B messages meeting the NUC or NIC criteria as indicated in 5.2.3.5.1, a non-precision time source shall be allowed. In such cases, where there is no appropriate precision time source available, the receiving system shall establish an appropriate internal clock or counter having a maximum clock cycle or count time of 20 milliseconds. The established cycle or clock count shall have a minimum range of 300 seconds and a resolution of 0.0078125 (1/128) seconds.

*Note.*— *The use of a non-precision time reference as described above is intended to allow the report time of applicability to accurately reflect the time intervals applicable to reports within a sequence. For example the applicable time interval between state vector reports could be accurately determined by a client application, even though the absolute time (e.g. UTC measured time) would not be indicated by the report.*

#### 5.2.3.6 REPORTING REQUIREMENTS

5.2.3.6.1 *Reporting requirements for Type I Mode S extended squitter airborne receiving systems.* As a minimum, the report assembler function associated with Type I Mode S extended squitter receiving systems, as defined in 5.2.3, shall support that subset of ADS-B and TIS-B reports and report parameters, that are required by the specific client applications being served by that receiving system.

5.2.3.6.2 *Reporting requirements for Type II Mode S extended squitter airborne receiving systems.* The report assembler function associated with Type II receiving systems, as defined in 5.2.3, shall generate ADS-B and TIS-B reports according to the class of the receiving system as shown in Table 5-4 when the prerequisite ADS-B and/or TIS-B messages are being received.

5.2.3.6.3 *Reporting requirements for Mode S extended squitter ground receiving systems.* As a minimum, the report assembler function associated with Mode S extended squitter ground receiving systems, as defined in 5.2.3, shall support that subset of ADS-B reports and report parameters, that are required by the specific client applications being served by that receiving system.

## 5.2.4 Interoperability

The Mode S extended squitter receiving system shall provide interoperability with both version 0 and version 1 extended squitter ADS-B message formats.

*Note 1.— Version 0 and version 1 messages are defined in the Technical Provisions for Mode S Services and Extended Squitter (Doc 9871).*

*Note 2.— Techniques for providing interoperability of version 0 and version 1 ADS-B message formats are described in the Manual on the Secondary Surveillance Radar (SSR) Systems (Doc 9684) and further information is provided in RTCA DO-260A, Appendix N.*

### 5.2.4.1 INITIAL MESSAGE DECODING

The Mode S extended squitter receiving system shall, upon acquiring a new ADS-B target, initially apply the decoding provisions applicable to version 0 (zero) ADS-B messages until or unless an operational status message is received indicating version 1 (one) message format is in use.

### 5.2.4.2 APPLYING VERSION NUMBER

The Mode S extended squitter receiving system shall decode the version number information conveyed in the operational status message and shall apply the corresponding decoding rules, version 0 (zero) or version 1 (one), for the decoding of the subsequent extended squitter ADS-B messages from that specific airborne or vehicle.

### 5.2.4.3 HANDLING OF RESERVED MESSAGE SUBFIELDS

The Mode S extended squitter receiving system shall ignore the contents of any message subfield defined as reserved.

*Note.— This provision supports interoperability between message versions by allowing the definition of additional parameters that will be ignored by earlier receiver versions and correctly decoded by newer receiver versions.*

## TABLES FOR CHAPTER 5

Table 5-1. ADS-B Class A equipment characteristics

<i>Equipment class</i>	<i>Minimum transmit power (at antenna terminal)</i>	<i>Maximum transmit power (at antenna terminal)</i>	<i>Airborne or surface</i>	<i>Minimum extended squitter message capability required (see Note 2)</i>
A0 (Minimum)	18.5 dBW (see Note 1)	27 dBW	Airborne	Airborne position A/C identification and type Airborne velocity A/C operational status Extended squitter A/C status
			Surface	Surface position A/C identification and type A/C operational status Extended squitter A/C status
A1 (Basic)	21 dBW	27 dBW	Airborne	Airborne position A/C identification and type Airborne velocity A/C operational status Extended squitter A/C status
			Surface	Surface position A/C identification and type A/C operational status Extended squitter A/C status
A2 (Enhanced)	21 dBW	27 dBW	Airborne	Airborne position A/C identification and type Airborne velocity A/C operational status Extended squitter A/C status Reserved for target state and status
			Surface	Surface position A/C identification and type A/C operational status Extended squitter A/C status
A3 (Extended)	23 dBW	27 dBW	Airborne	Airborne position A/C identification and type Airborne velocity A/C operational status Extended squitter A/C status Reserved for target state and status
			Surface	Surface position A/C identification and type A/C operational status Extended squitter A/C status
<p><i>Note 1.— See Chapter 3, 3.1.2.10.2 for restrictions on the use of this category of Mode S transponder.</i></p> <p><i>Note 2.— The extended squitter messages applicable to Class A equipment are defined in Version 1 of extended squitter formats of the Technical Provisions for Mode S Services and Extended Squitter (Doc 9871).</i></p>				

Table 5-2. ADS-B Class B equipment characteristics

<i>Equipment class</i>	<i>Minimum transmit power (at antenna terminal)</i>	<i>Maximum transmit power (at antenna terminal)</i>	<i>Airborne or surface</i>	<i>Minimum extended squitter message capability required</i>
B0 (Airborne)	18.5 dBW (see Note 1)	27 dBW	Airborne	Airborne position A/C identification and type Airborne velocity A/C operational status Extended squitter A/C status
			Surface	Surface position A/C identification and type A/C operational status Extended squitter A/C status
B1 (Airborne)	21 dBW	27 dBW	Airborne	Airborne position A/C identification and type Airborne velocity A/C operational status Extended squitter A/C status
			Surface	Surface position A/C identification and type A/C operational status Extended squitter A/C status
B2 Low (Ground Vehicle)	8.5 dBW	< 18.5 dBW (see Note 2)	Surface	Surface position A/C identification and type A/C operational status
B2 (Ground Vehicle)	18.5 dBW	27 dBW (see Note 2)	Surface	Surface position A/C identification and type A/C operational status
B3 (Fixed Obstacle)	18.5 dBW	27 dBW (see Note 2)	Airborne (see Note 3)	Airborne position A/C identification and type A/C operational status

*Note 1.— See Chapter 3, 3.1.2.10.2 for restrictions on the use of this category of Mode S transponder.*

*Note 2.— The appropriate ATS authority is expected to get the maximum power level permitted.*

*Note 3.— Fixed obstacles use the airborne ADS-B message formats since knowledge of their location is of primary interest to airborne aircraft.*

Table 5-3. Reception performance for airborne receiving systems

Receiver class	Intended air-to-air operational range	Receiver minimum trigger threshold level (MTL)	Reception technique	Required extended squitter ADS-B message support (see Note 3)	Required extended squitter TIS-B message support (see Note 4)
A0 (Basic VFR)	10 nmi.	-72 dBm (see Note 1)	Standard (See Note 2)	Airborne position Surface position Airborne velocity Airborne identification and type Extended squitter airborne status Airborne operational status	Fine airborne position Coarse airborne position Fine surface position Identification and type Airborne velocity Management
A1 (Basic IFR)	20 nmi.	-79 dBm (see Note 1)	Enhanced (See Note 2)	Airborne position Surface position Airborne velocity Airborne identification and type Extended squitter airborne status Airborne operational status	Fine airborne position Coarse airborne position Fine surface position Identification and type Airborne velocity Management
A2 (Enhanced IFR)	40 nmi.	-79 dBm (see Note 1)	Enhanced (See Note 2)	Airborne position Surface position Airborne velocity Airborne identification and type Extended squitter airborne status Airborne operational status Reserved for target state and status	Fine airborne position Coarse airborne position Fine surface position Identification and type Airborne velocity Management
A3 (Extended capability)	90 nmi.	-84 dBm (and -87 dBm at 15% probability of reception – see Note 1)	Enhanced (See Note 2)	Airborne position Surface position Airborne velocity Airborne identification and type Extended squitter airborne status Airborne operational status Reserved for target state and status	Fine airborne position Coarse airborne position Fine surface position Identification and type Airborne velocity Management

*Note 1.— Specific MTL is referenced to the signal level at the output terminal of the antenna, assuming a passive antenna. If electronic amplification is integrated into the antenna assembly, then the MTL is referenced at the input to the amplifier. For Class A3 receivers, a second performance level is defined at a received signal level of -87 dBm where 15 per cent of the messages are to be successfully received. MTL values refer to reception under non-interference conditions.*

*Note 2.— The extended squitter receiver reception techniques are defined in 5.2.2.4. “Standard” reception techniques refer to the baseline techniques, as required for ACAS 1 090 MHz receivers, that are intended to handle single overlapping Mode A/C fruit. “Enhanced” reception techniques refer to techniques intended to provide improved reception performance in the presence of multiple overlapping Mode A/C fruit and improved decoder re-triggering in the presence of overlapping stronger Mode S fruit. The requirements for the enhanced reception techniques that are applicable to the specific airborne receiver classes are defined in 5.2.2.4.*

*Note 3.— The extended squitter messages are defined in the Technical Provisions for Mode S Services and Extended Squitter (Doc 9871). However, the target state and status message, as defined in the Manual on Mode S Specific Services (Doc 9688), is not yet at the same level of maturity as the other ADS-B messages.*

*Note 4.— The TIS-B messages are defined in the Technical Provisions for Mode S Services and Extended Squitter (Doc 9871).*

**Table 5-4. Mode S extended squitter airborne receiving system reporting requirements**

<i>Receiver class</i>	<i>Minimum ADS-B reporting requirements</i>	<i>Minimum TIS-B reporting requirements</i>
A0 (Basic VFR)	ADS-B state vector report (per 5.2.3.1.1) and ADS-B mode status report (per 5.2.3.1.2)	TIS-B state report and TIS-B management report
A1 (Basic IFR)	ADS-B state vector report (per 5.2.3.1.1) and ADS-B mode status report (per 5.2.3.1.2) and ADS-B air referenced velocity report (ARV) (per 5.2.3.1.3)	TIS-B state report and TIS-B management report
A2 (Enhanced IFR)	ADS-B state vector report (per 5.2.3.1.1) and ADS-B mode status report (per 5.2.3.1.2) and ADS-B ARV report (per 5.2.3.1.3) and Reserved for ADS-B target state report (per 5.2.3.1.4)	TIS-B state report and TIS-B management report
A3 (Extended capability)	ADS-B state vector report (per 5.2.3.1.1) and ADS-B mode status report (per 5.2.3.1.2) and ADS-B ARV report (per 5.2.3.1.3) and Reserved for ADS-B target state report (per 5.2.3.1.4)	TIS-B state report and TIS-B management report



FIGURE FOR CHAPTER 5

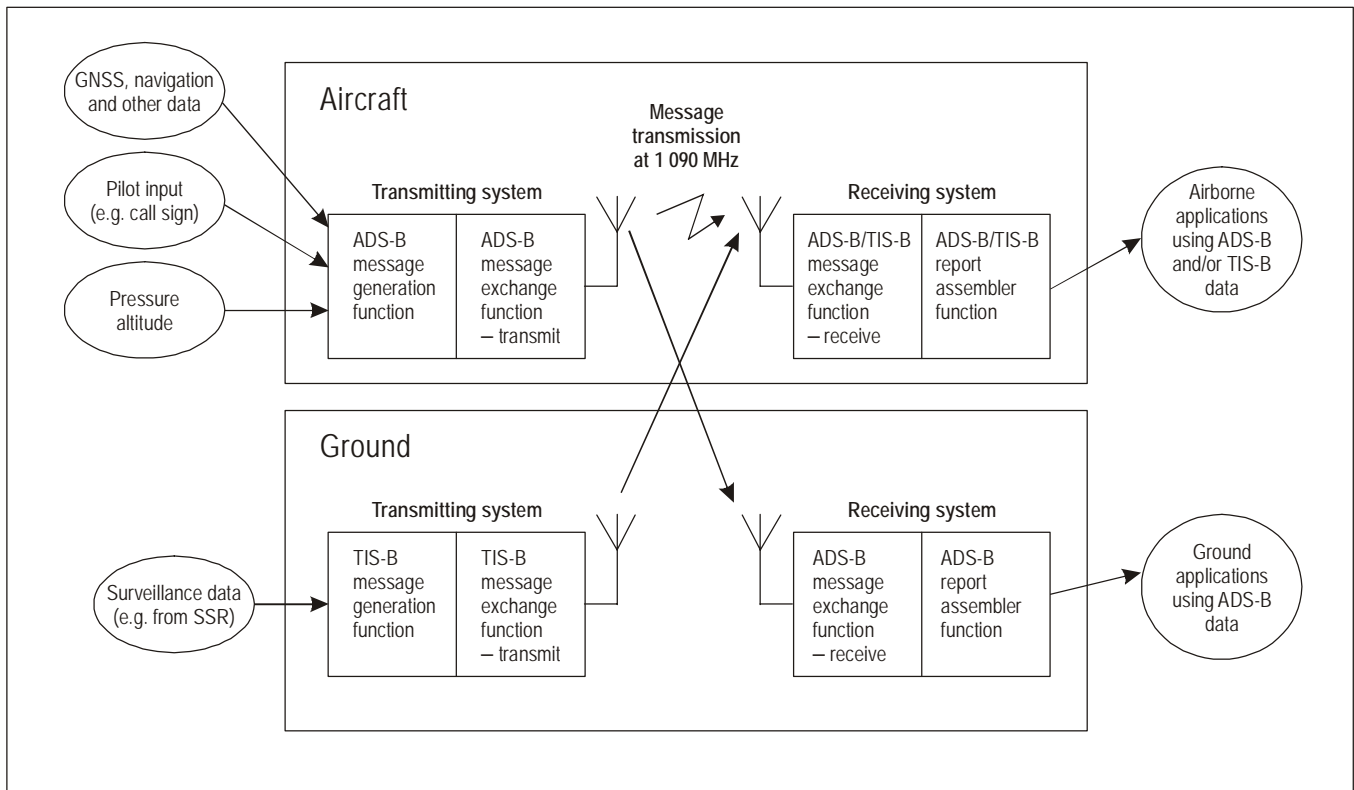

Figure 5-1. ADS-B/TIS-B system functional model



## CHAPTER 6. MULTILATERATION SYSTEMS

*Note 1.— Multilateration (MLAT) systems use the time difference of arrival (TDOA) of the transmissions of an SSR transponder (or the extended squitter transmissions of a non-transponder device) between several ground receivers to determine the position of the aircraft (or ground vehicle). A multilateration system can be:*

- a) passive, using transponder replies to other interrogations or spontaneous squitter transmissions;*
- b) active, in which case the system itself interrogates aircraft in the coverage area; or*
- c) a combination of a) and b).*

*Note 2.— Material contained in EUROCAE ED-117 – MOPS for Mode S Multilateration Systems for Use in A-SMGCS and ED-142 – Technical Specifications for Wide Area Multilateration System (WAM) provides a good basis for planning, implementation and satisfactory operation of MLAT systems for most applications.*

### 6.1 DEFINITIONS

**Multilateration (MLAT) System.** A group of equipment configured to provide position derived from the secondary surveillance radar (SSR) transponder signals (replies or squitters) primarily using time difference of arrival (TDOA) techniques. Additional information, including identification, can be extracted from the received signals.

**Time Difference of Arrival (TDOA).** The difference in relative time that a transponder signal from the same aircraft (or ground vehicle) is received at different receivers.

### 6.2 FUNCTIONAL REQUIREMENTS

6.2.1 Radio frequency characteristics, structure and data contents of signals used in 1 090 MHz MLAT systems shall conform to the provisions of Chapter 3.

6.2.2 An MLAT system used for air traffic surveillance shall be capable of determining aircraft position and identity.

*Note 1.— Depending on the application, either two- or three-dimensional position of the aircraft may be required.*

*Note 2.— Aircraft identity may be determined from:*

- a) Mode A code contained in Mode A or Mode S replies; or*
- b) Aircraft identification contained in Mode S replies or extended squitter identity and category message.*

*Note 3.— Other aircraft information can be obtained by analysing transmissions of opportunity (i.e. squitters or replies to other ground interrogations) or by direct interrogation by the MLAT system.*

6.2.3 Where an MLAT system is equipped to decode additional position information contained in transmissions, it shall report such information separately from the aircraft position calculated based on TDOA.

### 6.3 PROTECTION OF THE RADIO FREQUENCY ENVIRONMENT

*Note.— This section only applies to active MLAT systems.*

6.3.1 In order to minimize system interferences the effective radiated power of active interrogators shall be reduced to the lowest value consistent with the operationally required range of each individual interrogator site.

*Note.— Guidance material on power consideration is contained in the Aeronautical Surveillance Manual (Doc 9924).*

6.3.2 An active MLAT system shall not use active interrogations to obtain information that can be obtained by passive reception within each required update period.

*Note.— Transponder occupancy will be increased by the use of omnidirectional antennas. It is particularly significant for Mode S selective interrogations because of their higher transmission rate. All Mode S transponders will be occupied decoding each selective interrogation not just the addressed transponder.*

6.3.3 The set of transmitters used by all active MLAT systems in any part of the airspace shall not occupy any transponder more than 2 per cent of the time.

*Note.— The use of active MLAT systems may be even more restrictive in some regions.*

6.3.4 Active MLAT systems shall not use Mode S All-Call interrogations.

*Note.— Mode S aircraft can be acquired by the reception of acquisition squitter or extended squitter even in airspace where there are no active interrogators.*

### 6.4 PERFORMANCE REQUIREMENTS

6.4.1 The performance characteristics of the MLAT system used for air traffic surveillance shall be such that the intended operational service(s) can be satisfactorily supported.

## CHAPTER 7. TECHNICAL REQUIREMENTS FOR AIRBORNE SURVEILLANCE APPLICATIONS

*Note 1.— Airborne surveillance applications are based on aircraft receiving and using ADS-B message information transmitted by other aircraft/vehicles or ground stations. The capability of an aircraft to receive and use ADS-B/TIS-B message information is referred to as ADS-B/TIS-B IN.*

*Note 2.— Initial airborne surveillance applications use ADS-B messages on 1 090 MHz extended squitter to provide airborne traffic situational awareness (ATSA) and are expected to include “In-trail procedures” and “Enhanced visual separation on approach”.*

*Note 3.— Detailed description of aforementioned applications can be found in RTCA/DO-289 and DO-312.*

### 7.1 GENERAL REQUIREMENTS

#### 7.1.1 Traffic data functions

*Note.— The aircraft transmitting ADS-B messages used by other aircraft for airborne surveillance applications is referred to as the reference aircraft.*

##### 7.1.1.1 IDENTIFYING THE REFERENCE AIRCRAFT

7.1.1.1.1 The system shall support a function to identify unambiguously each reference aircraft relevant to the application.

##### 7.1.1.2 TRACKING THE REFERENCE AIRCRAFT

7.1.1.2.1 The system shall support a function to monitor the movements and behaviour of each reference aircraft relevant to the application.

##### 7.1.1.3 TRAJECTORY OF THE REFERENCE AIRCRAFT

7.1.1.3.1 **Recommendation.**— *The system should support a computational function to predict the future position of a reference aircraft beyond simple extrapolation.*

*Note.— It is anticipated that this function will be required for future applications.*

#### 7.1.2 Displaying traffic

*Note.— Provisions contained in this section apply to cases wherein tracks generated by ACAS and by reception of ADS-B/TIS-B IN messages are shown on a single display.*

7.1.2.1 The system shall display only one track for each distinct aircraft on a given display.

*Note.— This is to ensure that tracks established by ACAS and ADS-B/TIS-B IN are properly correlated and mutually validated before being displayed.*

7.1.2.2 Where a track generated by ADS-B/TIS-B IN and a track generated by ACAS have been determined to belong to the same aircraft, the track generated by ADS-B/TIS-B IN shall be displayed.

*Note.— At close distances, it is possible that the track generated by ACAS provides better accuracy than the track generated by ADS-B/TIS-B IN. The requirement above ensures the continuity of the display.*

7.1.2.3 The display of the tracks shall comply with the requirements of ACAS traffic display.

*Note.— Section 4.3 addresses colour coding and readability of the display.*

---

## **ATTACHMENT TO VOLUME IV**

### **Guidance material related to airborne collision avoidance system (ACAS)**

*Note 1.— The following material is intended to provide guidance concerning the technical characteristics of the airborne collision avoidance system (ACAS) having vertical resolution capability (ACAS II, unless stated otherwise). ACAS SARPs are contained in Chapter 4.*

*Note 2.— Non-SI alternative units are used as permitted by Annex 5, Chapter 3, Section 3.2.2. In limited cases, to ensure consistency at the level of the logic calculations, units such as ft/s, NM/s and kt/s are used.*

#### **1. EQUIPMENT, FUNCTIONS AND CAPABILITIES**

##### **1.1 ACAS equipment characteristics**

1.1.1 ACAS equipment includes an ACAS processing unit, Mode S transponder, control unit, appropriate antennas and means of providing advisories.

1.1.2 ACAS equipment in the aircraft interrogates SSR transponders on other aircraft in its vicinity and listens for the transponder replies. By computer analysis of these replies, the ACAS equipment determines which aircraft represent potential collision threats and provides appropriate indications (advisories) to the flight crew to avoid collisions.

1.1.3 ACAS equipment is capable of providing two classes of advisories. Traffic advisories (TAs) indicate the approximate positions of intruding aircraft that may later cause resolution advisories. Resolution advisories (RAs) propose vertical manoeuvres that are predicted to increase or maintain separation from threatening aircraft.

##### **1.2 Advisories provided**

###### **1.2.1 TRAFFIC ADVISORIES**

TAs may indicate the range, range rate, altitude, altitude rate, and bearing of the intruding aircraft relative to own aircraft. TAs without altitude information may also be provided on Mode C or Mode S-equipped aircraft that do not have an automatic altitude reporting capability. The information conveyed in ACAS TAs is intended to assist the flight crew in sighting nearby traffic.

###### **1.2.2 RESOLUTION ADVISORIES**

1.2.2.1 If the threat detection logic in the ACAS computer determines that an encounter with a nearby aircraft could lead to a near-collision or collision, the computer threat resolution logic determines an appropriate vertical manoeuvre that will

ensure the safe vertical separation of the ACAS aircraft. The selected manoeuvre ensures adequate vertical separation within constraints imposed by the climb rate capability and proximity to the ground of the ACAS aircraft.

1.2.2.2 The RAs provided to the pilot can be divided into two categories: corrective advisories, which instruct the pilot to deviate from the current flight path (e.g. “CLIMB” when the aircraft is in level flight); and preventive advisories, which advise the pilot to maintain or avoid certain vertical speeds (e.g. “DON’T CLIMB” when the aircraft is in level flight).

1.2.2.3 Under normal circumstances, ACAS issues only one RA during an encounter with one or multiple intruders. The RA is issued when, or shortly after, the (first) intruder becomes a threat, is maintained as long as the (any) intruder remains a threat, and is cancelled when the (last) intruder ceases to be a threat. However, the indication given to the flight crew as part of that RA may be modified. It may be strengthened or even reversed when a threat modifies its altitude profile or when the detection of a second or third threat changes the initial assessment of the encounter. It may also be weakened when adequate separation has been achieved but the (any) intruder temporarily remains a threat.

### 1.2.3 WARNING TIMES

If a threat is detected, the ACAS equipment generates an RA some time before the closest approach of the aircraft. The amount of warning time depends on the protected volume selected for ACAS system use. The nominal resolution advisory time before closest approach used by ACAS varies from 15 to 35 seconds. A TA will nominally be issued between 5 and 20 seconds in advance of an RA. Warning times depend on sensitivity level as described in 3.5.12.

### 1.2.4 AIR-AIR COORDINATION OF RESOLUTION ADVISORIES

1.2.4.1 If the aircraft detected by the ACAS equipment has only a Mode A/C transponder and automatic pressure-altitude reporting equipment, its pilot will not be aware that it is being tracked by the ACAS-equipped aircraft. When the pilot of the ACAS aircraft receives an RA in an encounter with such an aircraft and manoeuvres as advised, the ACAS aircraft will be able to avoid the intruding aircraft provided the intruder does not accelerate so as to defeat the manoeuvre of the ACAS aircraft.

1.2.4.2 If the intruding aircraft is equipped with ACAS, a coordination procedure is performed via the air-to-air Mode S data link in order to ensure that the ACAS RAs are compatible.

### 1.2.5 AIR-GROUND COMMUNICATION

1.2.5.1 ACAS may communicate with ground stations using the Mode S air-ground data link. The transmission of sensitivity level control commands to ACAS equipment by Mode S ground stations is one aspect of communication. This feature permits a Mode S ground station to adapt the RA warning time to the local traffic environment as an ACAS aircraft moves through the region of coverage of the station. An effective trade-off between collision warning time and alert rate is thereby ensured.

1.2.5.2 The Mode S air-ground data link may also be used to transmit ACAS RAs to Mode S ground stations. This information can then be used by air traffic services to monitor ACAS RAs within an airspace of interest.

### 1.2.6 FUNCTIONS PERFORMED BY ACAS

1.2.6.1 The functions executed by ACAS are illustrated in Figure A-1. To keep the illustration simple, the functions “own aircraft tracking” and “intruder aircraft tracking” have been represented once in Figure A-1, under “surveillance”. However, the trackers that are intended to support the collision avoidance function may not be suitable to support the surveillance function. Separate tracking functions may be required to adequately support both the collision avoidance and the surveillance functions.



1.2.6.2 Surveillance is normally executed once per cycle; however, it may be executed more frequently or less frequently for some intruders. For example, surveillance may be executed less frequently for some non-threatening intruders to respect interference limiting inequalities or it may be executed more frequently for some intruders to improve the azimuth estimate.

1.2.6.3 Parameters used in the implementation of the ACAS functions are adjusted automatically or manually to maintain collision avoidance protection with minimal interference to normal air traffic control (ATC) operations.

### 1.3 Intruder characteristics

#### 1.3.1 TRANSPONDER EQUIPAGE OF INTRUDER

ACAS provides RAs on aircraft equipped with altitude reporting Mode A/C or Mode S transponders. Some aircraft are equipped with SSR transponders but do not have altitude encoders. ACAS cannot generate RAs in conflicts with such aircraft because, without altitude information, a collision threat assessment cannot be made. ACAS equipment can generate only TAs on such aircraft, describing their ranges, range rates and bearings. Aircraft equipped with Mode A only transponders and those not equipped with or not operating Mode A/C or Mode S transponders cannot be tracked by ACAS.

#### 1.3.2 INTRUDER CLOSING SPEEDS AND TRAFFIC DENSITIES

1.3.2.1 ACAS equipment designed for operation in high density airspace is capable of providing overall surveillance performance on intruders as defined in Chapter 4, 4.3.2 and Table 4-1.

1.3.2.2 The conditions enumerated in Table 4-1, which define two distinct density regions in the multi-dimensional condition space that affects ACAS performance, were extrapolated from airborne measurements of the performance of a typical ACAS. The airborne measurement data indicated that the track establishment probability will not drop abruptly when any of the condition bounds is exceeded.

1.3.2.3 The performance is stated in terms of probability of tracking a target of interest at a maximum closing speed in a given traffic density at least 30 seconds before the point of closest approach. The maximum traffic density associated with each of the two density regions is defined as:

$$\rho = n(r)/\pi r^2$$

where  $n(r)$  is the maximum 30-second time average of the count of SSR transponder-equipped aircraft (not counting own aircraft) above a circular area of radius  $r$  about the ACAS aircraft ground position. In the airborne measurements, the radii were different for the two density regions. In the high-density measurements the radius was 9.3 km (5 NM). In the low-density measurements the radius was 19 km (10 NM). Traffic density outside the limits of the circular area of constant density may be assumed to decrease inversely proportional to range so that the number of aircraft is given by:

$$n(r) = n(r_o)r/r_o$$

where  $r_o$  is the radius of the constant density region.

1.3.2.4 When the density is greater than 0.017 aircraft/km<sup>2</sup> (0.06 aircraft/NM<sup>2</sup>), the nominal radius of uniform density  $r_o$  is taken to be 9.3 km (5 NM). When the density is equal to or less than indicated above,  $r_o$  is nominally 18.5 km (10 NM).

1.3.2.5 The table is based on an additional assumption that at least 25 per cent of the total transponder-equipped aircraft in the highest density 0.087 aircraft/km<sup>2</sup> (0.3 aircraft/NM<sup>2</sup>) airspace are Mode S equipped. If fewer than 25 per cent are Mode S equipped, the track probability for Mode A/C aircraft may be less than 0.90 because of increased synchronous garble. If the

traffic density within  $r_o$  exceeds the limits given in the table or if the traffic count outside of  $r_o$  continues increasing faster than  $r$ , the actual track establishment probability for Mode A/C aircraft may also be less than 0.90 because of increased synchronous garble. If the closing speed exceeds the given limits, the tracks for Mode A/C and Mode S aircraft may be established late. If the number of other ACAS in the area exceeds the limits given in the table, the interference limiting requirements of Chapter 4, 4.3.2.2 require that the ACAS transmitter power and receiver sensitivity be further reduced, thereby resulting in a later establishment time. However, the track probability is expected to degrade gradually as any of these limits is exceeded.

1.3.2.6 The table reflects the fact that the ACAS tracking performance involves a compromise between closing speed and traffic density. Although it may not be possible to maintain a high probability of track when the traffic density and the intruder closing speed are both simultaneously large, the ACAS design is capable of reliable track establishment on high-speed intruders when operating in relatively low-density en-route airspace (typically characterized by densities of less than 0.017 aircraft/km<sup>2</sup>, i.e. 0.06 aircraft/NM<sup>2</sup>) or when operating in higher density, low-altitude terminal airspace where the closing speeds are typically below 260 m/s (500 kt) for operational reasons.

1.3.2.7 The table also accounts for the fact that higher closing speeds are associated with the forward direction than with the side or back directions so that the ACAS surveillance design is not required to provide reliable detection for the highest closing speeds in the side or back directions.

### 1.3.3 SYSTEM RANGE LIMITATIONS

The required nominal tracking range of the ACAS is 26 km (14 NM). However, when operating in high density, the interference limiting feature may reduce system range to approximately 9.3 km (5 NM). A 9.3 km (5 NM) range is adequate to provide protection for a 260 m/s (500 kt) encounter.

## 1.4 Control of interference to the electromagnetic environment

1.4.1 The ACAS equipment is capable of operating in all traffic densities without degrading the electromagnetic environment. Each ACAS equipment knows the number of other ACAS units operating in the local airspace. This knowledge is used to ensure that no transponder is suppressed by ACAS activity for more than 2 per cent of the time and to ensure that ACAS does not contribute to an unacceptably high fruit rate that would degrade ground SSR surveillance performance. Multiple ACAS units in the vicinity cooperatively limit their own transmissions. As the number of such ACAS units increases, the interrogation allocation for each of them decreases. Thus, every ACAS unit monitors the number of other ACAS units within detection range. This information is then used to limit its own interrogation rate and power as necessary. When this limiting is in full effect, the effective range of the ACAS units may not be adequate to provide acceptable warning times in encounters in excess of 260 m/s (500 kt). This condition is normally encountered at low altitude where this closing speed capability is sufficient. Whenever the ACAS aircraft is on the ground, ACAS automatically limits the power of its interrogations. This limiting is done by setting the ACAS count ( $n_a$ ) in the interference limiting inequalities to a value three times the measured value. This value is selected to ensure that an ACAS unit on the ground does not contribute any more interference to the electromagnetic environment than is unavoidable. This value will provide an approximate surveillance range of 5.6 km (3 NM) in the highest density terminal areas to support reliable ground ACAS surveillance of local airborne traffic and a 26 km (14 NM) range in very low density airspace to provide wide area surveillance in the absence of an SSR.

1.4.2 The presence of an ACAS unit is announced to other ACAS units by the periodic transmission of an ACAS interrogation containing a message that gives the address of the ACAS aircraft. This transmission is sent nominally every 8 to 10 seconds using a Mode S broadcast address. Mode S transponders are designed to accept message data from a broadcast interrogation without replying. The announcement messages received by the ACAS aircraft's Mode S transponder are monitored by the interference limiting algorithms to develop an estimate of the number of ACAS units in the vicinity.

## 2. FACTORS AFFECTING SYSTEM PERFORMANCE

### 2.1 Synchronous garble

When a Mode C interrogation is transmitted, all the transponders that detect it reply. Since the reply duration is 21 microseconds, aircraft whose ranges from ACAS are within about 2.8 km (1.5 NM) of each other generate replies that persistently and synchronously overlap each other at the interrogating aircraft. The number of overlapping replies is proportional to the density of aircraft and their range from ACAS. Ten or more overlapping replies might be received in moderate density terminal areas. It is possible to decode reliably only about three overlapping replies. Hence, there is a need to reduce the number of transponders that reply to each interrogation. Whisper-shout and directional transmit techniques are available for controlling such synchronous garble (see 3.2 and 3.3). They are both needed in ACAS equipment operating in the highest traffic densities.

### 2.2 Multipath from terrain reflections

2.2.1 SSR transponders use quarter-wave monopole antennas mounted on the bottom of the aircraft. A stub antenna of this sort has a peak elevation gain at an angle of 20 to 30 degrees below the horizontal plane. This is suitable for ground-air surveillance, but the direct air-air surveillance path may operate at a disadvantage relative to the ground reflection path, particularly over water.

2.2.2 If the ACAS unit uses a bottom-mounted antenna, there are geometries for which the reflected signal is consistently stronger than the direct signal. However, when a top-mounted antenna is used for interrogation, its peak gain occurs at a positive elevation angle and the signal-to-multipath ratio is improved. Thus, when ACAS transmits from the top-mounted antenna, the effects of multipath are reduced significantly. Even when a top-mounted antenna is used, the multipath will still occasionally exceed the receiver threshold. Thus, there is need to reject low-level multipath. ACAS can achieve this rejection through the use of variable receiver thresholds (see 3.4).

### 2.3 Altimetry data quality

#### 2.3.1 MEASUREMENT ERRORS

2.3.1.1 The vertical separation between two conflicting aircraft is measured as the difference between own altitude and the intruder's altitude as reported in its Mode C or Mode S reply. If the ACAS aircraft is an air carrier, it will normally have accurate altimetry; an intruding aircraft might have less accurate altimetry.

2.3.1.2 Errors in altimetry can cause two types of effects: first, if the aircraft are on a near collision course, errors could indicate safe passage, and the impending near mid-air collision might not be resolved by ACAS; second, if the aircraft are on a near collision course, but are separated in altitude, errors could lead to an ACAS manoeuvre in the wrong direction which could induce an even closer encounter.

2.3.1.3 ACAS attempts to achieve a difference of at least 90 m (300 ft) between aircraft at closest approach based on reported altitude. Thus, if the combination of intruder and ACAS altimetry errors approached 90 m (300 ft), there would be finite risk of inadequate vertical separation despite the presence of ACAS. Studies of the expected altimetry errors of both ACAS and non-ACAS aircraft at altitudes from sea level to FL 400 have concluded that the risk is essentially negligible if both aircraft are equipped with high accuracy altimetry systems that can achieve root-sum-square (RSS) errors of approximately 15 m (50 ft). It was further concluded that if an ACAS with high accuracy altimetry operates in a traffic environment consisting of typical general aviation aircraft (with RSS errors of approximately 30 m (100 ft), normally distributed), then altimetry errors

will occasionally lead to inadequate ACAS RAs. However, this will not occur often enough to seriously interfere with the effectiveness of the system. Performance was considered to be inadequate if both aircraft in an encounter had a low accuracy altimetry system. This led to the requirement that ACAS possess a high accuracy system.

### 2.3.2 ALTITUDE BIT FAILURE

If the Mode C or Mode S altitude reports from the intruding aircraft or the altitude data for own aircraft contain bit errors, ACAS may develop erroneous estimates of the corresponding vertical position or rate. These errors can have effects similar to the effects of measurement errors. Such errors are most likely to occur when the altitude data source is a Gilham encoder, and the use of Gilham encoded data for own aircraft altitude can have serious adverse consequences. When there is no alternative source than Gilham encoded data, two encoders must be used and a comparison function in the Mode S transponder used to detect errors in the altitude data before they are provided to ACAS.

### 2.3.3 CREDIBILITY OF OWN AIRCRAFT ALTITUDE

All sources of own altitude data are required to be checked for credibility, including fine altitude data (which can come from various sources: gyro, air data computer, etc.) and radar altitude data.

## 2.4 Potential for ground-based SSR site monitors (PARROT) to cause spurious traffic and resolution advisories

An ACAS interrogates all SSR transponders within range, including ground-based transponder installations used to monitor the operation of ground radar systems, or test transponders. If these ground-based transponders reply with false altitude data, the potential exists for an ACAS to generate spurious TAs and RAs. To prevent this problem, information on the operation of position adjustable range reference orientation transponders (PARROT) and transponder test facilities is provided in the *Manual of Secondary Surveillance Radar (SSR) Systems* (Doc 9684).

## 2.5 Allocation and assignment of SSR Mode S addresses

To ensure safe operation, the system requires that all Mode S-equipped aircraft have unique addresses. Multiple aircraft with the same address or aircraft with addresses not compliant with Annex 10, Volume III, Part I, Chapter 9, can adversely affect the surveillance and coordination functions.

## 2.6 Potential for TCAS I systems to affect ACAS II performance

*Note.— For the purpose of this material, TCAS I is defined as a system that uses SSR interrogations to provide aircrew with traffic alert warning information as an aid to the “see and avoid” principle.*

Some TCAS I systems employ ACAS II interference limiting techniques with resolution advisories suppressed. These systems do not comply with ACAS I SARPs. Because ACAS II interference limiting relies on direct interaction with other ACAS II aircraft (using the ACAS broadcast and Mode S transponder replies), the presence of such TCAS I aircraft can directly influence the surveillance performance of nearby ACAS II aircraft. If such TCAS I systems are fitted to aircraft that are known to operate in close proximity to each other (e.g. rotorcraft or gliders) then the effect may reduce the surveillance range of other ACAS II aircraft and delay the provision of collision avoidance warnings. In light of these concerns, TCAS I systems (which

employ ACAS II interference limiting techniques) must not be used for aircraft which are known to operate in close proximity to each other for sustained periods of time. Care must be taken to ensure that the effect on the SSR electromagnetic environment is acceptable, since these TCAS I units may be fitted in very large numbers.

### 3. CONSIDERATIONS ON TECHNICAL IMPLEMENTATION

#### 3.1 System operation

##### 3.1.1 SURVEILLANCE OF INTRUDERS

3.1.1.1 The main purposes of the surveillance processes described below are to obtain position reports and to correlate these to form tracks. This involves the use of trackers and requires the estimation of rates.

3.1.1.2 The ACAS unit transmits an interrogation sequence nominally once per second. The interrogations are transmitted at a nominal effective radiated power level of  $+54 \pm 2$  dBm as measured at zero degree elevation relative to the longitudinal axis of the aircraft. When these interrogations are received by Mode A/C and Mode S altitude reporting transponders, the transponders transmit replies that report their altitude. The ACAS unit computes the range of each intruding aircraft by using the round-trip time between the transmission of the interrogation and the receipt of the reply. Altitude rate and range rate are determined by tracking the reply information.

3.1.1.3 In the absence of interference, overload, interference-limiting conditions, or other degrading effects, the equipment will nominally be capable of providing surveillance for Mode A/C and Mode S targets out to a range of 26 km (14 NM). However, because the surveillance reliability degrades as the range increases, the equipment should assess as possible collision threats only those targets within a maximum range of 22 km (12 NM). No target outside of this range should be eligible to generate an RA. However, ACAS is able to detect ACAS broadcast interrogations from ACAS-equipped aircraft out to a nominal range of 56 km (30 NM).

3.1.1.4 The equipment should have the capacity for surveillance of any mix of Mode A/C or Mode S targets up to a total peak target capacity of 30 aircraft. ACAS equipment is nominally capable of reliable surveillance of high-closing-speed targets in a peak traffic density of up to 0.017 aircraft per square km (0.06 aircraft per square NM) or approximately 27 aircraft in a 26 km (14 NM) radius.

3.1.1.5 When the average traffic density exceeds the above value, the reliable surveillance range decreases. ACAS equipment is capable of providing reliable surveillance of targets closing only up to 260 m/s (500 kt) in an average traffic density of 0.087 aircraft per square km (0.3 aircraft per square NM). The surveillance range required for 260 m/s (500 kt) targets is about 9.3 km (5 NM). It is possible to provide 9.3 km (5 NM) surveillance in a short-term peak traffic density of 0.087 aircraft/km<sup>2</sup> (0.3 aircraft/NM<sup>2</sup>) or more without exceeding a total target capacity of 30. If the overall target count ever exceeds 30 at any range up to 26 km (14 NM), the long-range targets may always be dropped without compromising the ability to provide reliable surveillance of lower-speed targets. Thus a peak capability of 30 targets (any mix of Mode A/C or Mode S) is adequate for ACAS and if the number of Mode A/C plus Mode S targets under surveillance exceeds 30, excess targets are to be deleted in order of decreasing range without regard to target type.

##### 3.1.2 SURVEILLANCE OF INTRUDERS WITH MODE A/C TRANSPONDERS

3.1.2.1 Surveillance of Mode A/C transponders is accomplished by the periodic transmission of a Mode C-only all-call (intermode) interrogation (Chapter 3, 3.1.2.1.5.1.2). This elicits replies from Mode A/C transponders, but not from Mode S transponders, thus preventing the replies of Mode S transponders from synchronously garbling the replies of Mode A/C

transponders. Other techniques for reducing synchronous garble are (1) the use of directional antennas to interrogate only those aircraft in an azimuth wedge, and (2) the use of a sequence of variable power suppressions and interrogations (known as “whisper-shout”) that interrogates only aircraft that have similar link margins (see 3.2.2). The use of both of these techniques together provides a powerful tool for overcoming the effects of synchronous garble.

3.1.2.2 Whisper-shout employs a sequence of interrogations at different power levels transmitted during each surveillance update period. Each of the interrogations in the sequence, other than the one at lowest power, is preceded by a suppression transmission, where the first pulse of the interrogation serves as the second pulse of the suppression transmission. The suppression transmission pulse begins at a time 2 microseconds before the first pulse of the interrogation. The suppression pulse is transmitted at a power level lower than the accompanying interrogation so that the transponders that reply are only those that detect the interrogation and do not detect the suppression. To guard against the possibility that some transponders do not reply to any interrogation in the sequence, the suppression pulse is transmitted at a power level somewhat lower than that of the next lower interrogation. The time interval between successive interrogations should be at least 1 millisecond. This ensures that replies from transponders at long range are not mistaken for replies to the subsequent interrogation. All interrogations in the sequence are transmitted within a single surveillance update interval.

3.1.2.3 Responses to each Mode C-only all-call interrogation are processed to determine the range and altitude code of each reply. It is possible to determine the altitude codes for up to three overlapping replies if care is taken to identify the location of each of the received pulses.

3.1.2.4 After all of the replies are received in response to the whisper/shout sequence, duplicate replies should be merged so that only one “report” is produced for each detected aircraft. Reports may be correlated in range and altitude with the predicted positions of known intruders (i.e. with existing tracks). Since intruding aircraft are interrogated at a high rate (nominally once per second), good correlation performance is achieved using range and altitude. Mode A code is not needed for correlation. Reports that correlate are used to extend the associated tracks. Reports that do not correlate with existing tracks may be compared to previously uncorrelated reports to start new tracks. Before a new track is started, the replies that lead to its initiation may be tested to ensure that they agree in all of the most significant altitude code bits. A geometric calculation may be performed to identify and suppress specular false targets caused by multipath reflections from the terrain.

3.1.2.5 Tracks being initiated may be tested against track validity criteria prior to being passed to the collision avoidance algorithms. The purpose of these tests is to reject spurious tracks caused by garble and multipath. Spurious tracks are generally characterized by short track life.

3.1.2.6 Aircraft not reporting altitude in Mode C replies are detected using the Mode C reply framing pulses. These aircraft are tracked using range as the correlation criterion. The additional use of bearing for correlation will help to reduce the number of false non-Mode C tracks.

3.1.2.7 *Reply merging.* Multiple replies may be generated by a Mode A/C target that responds to more than one whisper-shout interrogation during each whisper-shout sequence or by a target that responds to interrogations from both the top and bottom antennas. The equipment is expected to generate no more than one position report for any target even though that target may respond to more than one interrogation during each surveillance update interval.

3.1.2.8 *Mode A/C surveillance initiation.* The equipment will pass the initial position reports to the collision avoidance algorithms only if the conditions in a) and b) below are satisfied:

- a) initially, a Mode C reply is received from the target in each of three consecutive surveillance update periods, and:
  - 1) the replies do not correlate with surveillance replies associated with other tracks;
  - 2) the range rate indicated by the two most recent replies is less than 620 m/s (1 200 kt);
  - 3) the oldest reply is consistent with the above range rate in the sense that its range lies within 95.3 m (312.5 ft) of a straight line passing through the two most recent replies;

4) the replies correlate with each other in their altitude code bits;

- b) a fourth correlating reply is received within five surveillance update intervals following the third reply of the three consecutive replies in a) above and is within  $\pm 60$  m ( $\pm 200$  ft) of the predicted altitude code estimate determined in a) 4) above.

3.1.2.8.1 The following is an example of an acceptable set of rules for assessing correlation of reply code bits and determining the initial altitude track code estimate for a target. Three replies correlate only if:

- a) all eight of their D, A and B code pulses agree; or
- b) seven of their D, A, and B code pulses agree and at least one of their C code pulses agrees.

3.1.2.8.2 The test for code agreement among the three replies is made individually for each of the reply pulse positions. This test is based on the presence of code pulses alone; agreement occurs for a given reply pulse position if all three replies are detected with ONE in the position or all three replies are detected with a ZERO in that position. The confidence associated with those pulse detections does not affect agreement.

3.1.2.8.3 The confidence flag for a reply pulse position is set “low” whenever there exists another received reply (either real or phantom) that could have had a pulse within  $\pm 0.121$  microsecond of the same position. Otherwise, the confidence flag is set “high”.

3.1.2.8.4 When agreement among the three replies does not occur for a given reply pulse position, the initial track pulse code estimate for that position is based on the values of the individual pulse codes and the confidence flags associated with those pulse codes in three replies.

3.1.2.8.5 When agreement fails for a given pulse position, the rules for estimating the initial track code for that position are based on the principle that “low” confidence ONEs are suspect. The rules are as follows:

- a) If in the most recent (third) reply the detected code for a given pulse position is “high” confidence or a ZERO, the initial track pulse code estimate for that position is the same as the code detected in that position in the most recent reply.
- b) If in the most recent reply the detected code for a given pulse position is a “low” confidence ONE, the initial track pulse code estimate for the position is the same as the code detected in that position in the second reply provided that was not also a “low” confidence ONE. If the second was also a “low” confidence ONE, the initial track pulse code estimate is the same as the code detected in that position in the first reply.

### 3.1.2.9 *MODE A/C SURVEILLANCE EXTENSION*

3.1.2.9.1 *General.* The equipment should continue to pass position reports for a target to the collision avoidance algorithms only if:

- a) the track has not been identified as an image (see 3.1.2.9.6); and
- b) the reply altitudes occur within an altitude window of  $\pm 60$  m (200 ft) centred on the altitude predicted from previous reply history; and
- c) all replies used for threat assessment after the initiation procedure occur within a range window centred on the range predicted from previous reply history.

3.1.2.9.2 *Range correlation.* The following is an example of an acceptable set of rules for determining the size of the range window:

- a) The tracks are processed individually in increasing range order with input range precision of at least 15 m (50 ft) and retained computational accuracy of at least 1.8 m (6 ft). Range is estimated and predicted by a recursive (alpha-beta) tracker with alpha of 0.67 and beta of 0.25.
- b) After each surveillance update a new range measurement is available for each target. Since the measurement includes errors, it must be smoothed based on previous measurements to obtain improved estimates of the current target position and velocity. The range and range rate estimation equations are as follows:

$$r(t) \text{ estimate} = r(t) \text{ prediction} + [\text{alpha} \times (r(t) \text{ measurement} - r(t) \text{ prediction})]$$

$$\dot{r}(t) \text{ estimate} = \dot{r}(t - T_p) \text{ estimate} + [(\text{beta}/T_p) \times (r(t) \text{ measurement} - r(t) \text{ prediction})],$$

where  $T_p$  is the time difference between the current and previous measurements.

- c) The gains, alpha and beta determine the relative degree of reliance on current and previous measurements; gains of unity would place complete reliance on the current measurement and result in no smoothing.
- d) The estimates obtained from the above equations are subsequently used to predict the range at the time of the next measurement as follows:

$$r(t + T_n) \text{ prediction} = r(t) \text{ estimate} + [\dot{r}(t) \text{ estimate} \times T_n]$$

where  $T_n$  is the time difference between the next measurement and the current measurement.

- e) The range correlation window is centred at the predicted range and has a half-window width as follows:

<div style="border: 1px solid black; padding: 5px; width: 150px; margin: 0 auto;"> <p style="text-align: center;">760 ft if coasted last interval</p> <p style="text-align: center;">570 ft if updated last interval</p> </div>	+	<div style="border: 1px solid black; padding: 5px; width: 250px; margin: 0 auto;"> <p style="text-align: center;">if track is not established: 0</p> <p style="text-align: center;">if track is established:</p> <p style="text-align: center;">2 000 ft, if <math>0.00 \text{ NM} \leq r &lt; 0.17 \text{ NM}</math></p> <p style="text-align: center;">1 000 ft, if <math>0.17 \text{ NM} \leq r &lt; 0.33 \text{ NM}</math></p> <p style="text-align: center;">600 ft, if <math>0.33 \text{ NM} \leq r &lt; 1.00 \text{ NM}</math></p> <p style="text-align: center;">240 ft, if <math>1.00 \text{ NM} \leq r &lt; 1.50 \text{ NM}</math></p> <p style="text-align: center;">0 ft, if <math>1.50 \text{ NM} \leq r</math></p> </div>
---	---	---

- f) If the track is above 3 050 m (10 000 ft), the term contained within the second pair of brackets is multiplied by four.

3.1.2.9.3 *Altitude correlation.* For the purposes of altitude correlation, altitude is estimated and predicted by an alpha-beta tracker with alpha of 0.28 and beta of 0.06. The tracker has retained computational accuracy of (30 m) (100 ft) divided by 16. The altitude prediction is rounded to the nearest 30 m (100 ft) increment and converted to grey code. The grey codes of the predicted altitude  $\pm 30$  m (100 ft) are also computed. The longer-term altitude predictions performed by the threat detection logic require a more accurate altitude tracking procedure (see 3.5.3). The reply(ies) that lies in the range correlation window is tested for altitude correlation in increasing range order. The track is updated with the first reply that has exact agreement (in all bits) with any of the three grey codes computed above. If no reply matches, two additional grey codes are computed and the process tried again. The two codes are the predicted altitude  $\pm 60$  m (200 ft).



3.1.2.9.4 *Track updating — establishment.* The updating reply (if any) is eliminated from further consideration in updating other tracks, or in the track initiation process. If there is no updating reply, the range and altitude estimates are set equal to the corresponding predicted values. If this is the sixth consecutive interval having no updating reply, the track is dropped. If there is an updating reply, and if the track is not identified as an image (see 3.1.2.9.6), the track is flagged as established, that is, it is now available for use by the threat detection logic. Once established, a track remains established until it is dropped, even if it subsequently satisfies the conditions for an image track.

3.1.2.9.5 *Test for track splits.* When all tracks have been processed, they are combined with the tracks that are newly initiated during the current scan, and then all the tracks are examined pairwise to determine if a given pair of tracks is likely to represent the same intruder. If:

- a) the ranges differ by at most 150 m (500 ft)
- b) the range rates differ by at most 4.6 m/s (8.9 kt)
- c) either
  - 1) the altitudes differ by at most 30 m (100 ft), or
  - 2) the altitude rates differ by at most 3 m/s (10 ft/s) and both tracks were initiated during the same scan,

only one of the tracks is retained, preference being given to the track showing the larger number of replies since initiation.

3.1.2.9.6 *Image track processing.* Those tracks that could have been formed by replies specularly reflected from the ground are referred to as image tracks. A track is identified as an image if there exists a track at shorter range (referred to as the real track) such that:

- a) the difference between the real altitude and the image altitude is less than or equal to 60 m (200 ft) for altitude-reporting targets, or both the image track and the real track are non-altitude-reporting; and
- b) the difference between the measured image range rate and the calculated image range rate  $\dot{r}_i$  is less than or equal to 21 m/s (40 kt), where the calculated image range rate is either (for the single-reflection case):

$$\dot{r}_i = \left(\frac{1}{2}\right) \left[ \dot{r} + \left(\frac{1}{2r_i - r}\right) \left[ ((2r_i - r)^2 - r^2 + (Z_0 - Z)^2)^{\frac{1}{2}} (\dot{Z}_0 + \dot{Z}) + r\dot{r} - (Z_0 - Z)(\dot{Z}_0 + \dot{Z}) \right] \right]$$

or (for the double-reflection case):

$$\dot{r}_i = \left(\frac{1}{r_i}\right) \left[ \left( r_i^2 - r^2 + (Z_0 - Z)^2 \right)^{\frac{1}{2}} (\dot{Z}_0 + \dot{Z}) + r\dot{r} - (Z_0 - Z)(\dot{Z}_0 - \dot{Z}) \right]$$

where:

$r_i$  is the image range,

$r$  is the real range,

$Z$  is the real altitude, for altitude reporting targets or  $Z$  is set to own altitude for non-altitude reporting targets, and

$Z_0$  is own altitude

If a track is identified as an image, it may be retained, but it cannot be flagged as established for use by the threat detection logic.

3.1.2.10 *Missing Mode A/C reports.* The equipment continues to pass to the collision avoidance algorithms predicted position reports for Mode A/C targets for six surveillance update intervals following the receipt of the last valid correlating reply. The equipment does not pass position reports for more than six surveillance update intervals following the receipt of the last valid correlating reply unless the target again satisfies the surveillance initiation criteria of 3.1.2.8.

### 3.1.3 SURVEILLANCE OF INTRUDERS WITH MODE S TRANSPONDERS

3.1.3.1 Efficient air-air surveillance techniques have been developed for intruders equipped with Mode S transponders. Because of Mode S selective address, there is no synchronous garble associated with surveillance of Mode S transponders. However, multipath must be dealt with and the surveillance of Mode S transponders should be accomplished with as few interrogations as possible to minimize interference.

3.1.3.2 The Mode S modulation formats are inherently more resistant to multipath than are the Mode A/C modulation formats. However, the greater length of the Mode S transmission makes it more likely to be overlapped by multipath. The use of top-mounted antennas and variable receiver thresholds (to protect the Mode S reply preamble) increases the multipath resistance to an acceptable level for reliable air-air surveillance. The use of antenna diversity transponders on ACAS aircraft provides an additional reliability margin for coordination between pairs of conflicting ACAS aircraft.

3.1.3.3 Mode S interrogation rates are kept low by passive detection of transponder transmissions and by interrogating once per second only those intruders that could become immediate threats. Intruders that are not likely to become immediate threats should be interrogated less frequently (i.e. once every 5 seconds). Passive address acquisition prevents unnecessary interference with other elements of the SSR and ACAS system. ACAS listens to Mode S all-call replies (DF = 11, acquisition squitter transmissions, Chapter 3, 3.1.2.8.5.1 or DF = 17, extended squitter transmissions, Chapter 3, 3.1.2.8.6.1). These may occur in response to Mode S ground station all-call interrogations or as spontaneous transmission (called squitters) at intervals ranging from 0.8 to 1.2 seconds for the acquisition squitter, and at shorter intervals for the extended squitter. Reception of squitters may be alternated between the top and bottom antennas. If reception is switched, it will be necessary to control the switching times to avoid undesirable synchronism with the squitters transmitted by Mode S antenna diversity transponders.

3.1.3.4 The 24-bit aircraft address in the squitter is protected by error coding to ensure a high probability of obtaining a correct address. Since the squitter transmission does not contain altitude information, ACAS attempts to obtain altitude passively from Mode S replies generated in response to ground interrogations or interrogations from other ACAS aircraft. If altitude is not received shortly after address detection, the Mode S aircraft is actively interrogated to obtain altitude.

3.1.3.5 After ACAS has determined the altitude of a detected Mode S aircraft, it compares the altitude of this aircraft to its own altitude to determine whether or not the target can be ignored or should be interrogated to determine its range and range rate. If the measured range and the estimated range rate indicate that it is (or could soon be) a collision threat, the intruder should be interrogated once per second and the resulting track data fed to the collision avoidance algorithms. An aircraft at longer range should be interrogated only as often as necessary to maintain track and ensure that it will be interrogated once per second before it becomes a collision threat.

3.1.3.6 The use of passive detection in combination with altitude comparison and a less frequent interrogation of non-threat intruders reduce the Mode S interrogation rate automatically when the local densities of other ACAS aircraft are very high. Therefore, a higher interrogation power level is available to improve surveillance performance.

#### 3.1.3.7 *MODE S SURVEILLANCE INITIATION*

3.1.3.7.1 The equipment is intended to provide Mode S surveillance with a minimum of Mode S interrogations. The identity of Mode S targets is determined by passively monitoring transmissions received with DF = 11 or DF = 17. Error

detection and correction is applied to the received squitters to reduce the number of addresses to be processed. The altitude of the Mode S targets from which a squitter has been received is determined by passive monitoring transmissions received with DF = 0 (short air-air surveillance replies, Chapter 3, 3.1.2.8.2) or DF = 4 (surveillance altitude replies, Chapter 3, 3.1.2.6.5) or active selective interrogations (air-air surveillance interrogation, Chapter 4, 4.3.8.4) and monitoring the corresponding air-air surveillance replies. The equipment monitors squitter and altitude replies whenever it is not transmitting, or receiving replies to, Mode S or Mode C interrogations. Each received reply is examined to determine what further action should be taken.

3.1.3.7.2 To reduce the number of unnecessary interrogations, a squitter target is not interrogated if so few squitters and altitude replies are received from it that no threat is indicated. Targets that might be a threat are called valid targets. The equipment is not intended to interrogate a target unless the altitude information indicates that it is within 3 050 m (10 000 ft) of own altitude. The ACAS aircraft interrogates targets from which it does not receive altitude information but does continue to receive error-free squitters. In order to establish timely acquisition of targets that transition the 3 050 m (10 000 ft) relative altitude boundary, the altitude of targets that are beyond 3 050 m (10 000 ft) of own altitude are monitored using unsolicited DF = 0 or DF = 4 replies, or in the absence of such replies, by periodically interrogating to elicit a DF = 0 reply.

3.1.3.7.3 The following is an example of one acceptable means of processing squitters and altitude replies to reduce unneeded interrogations:

- a) When a valid squitter is first received, a running sum initialized at 0 is associated with it. During each succeeding surveillance update interval the sum is decremented by 1 if no squitters or altitude replies with a particular address are received, and the sum is incremented by 16 for each reception of either a squitter or an altitude reply. The process continues until the sum equals or exceeds 20. When the sum becomes less than or equal to -20, the address is removed from the system. When it equals or exceeds +20, the target is declared to be valid.
- b) When a target has been declared to be valid, it is interrogated unless its altitude differed from the ACAS altitude by more than 3 050 m (10 000 ft). Otherwise, its altitude is monitored using DF = 0 or DF = 4 replies, or in the absence of such replies, by interrogating once every 10 seconds to elicit a DF = 0 reply.
- c) When any of these conditions are satisfied, the running sum continues to be incremented and decremented even though its value may exceed 20.

### 3.1.3.8 *MODE S RANGE ACQUISITION*

3.1.3.8.1 The equipment should transmit an acquisition interrogation (UF = 0, 16, AQ = 1, Chapter 3, 3.1.2.8.1.1) to determine the range of each valid target with relative altitude as defined above, or from which inadequate altitude information has been received.

3.1.3.8.2 If an acquisition interrogation fails to elicit a valid reply, additional interrogations should be transmitted. The total number of acquisition interrogations addressed to a single target must not exceed three within a single surveillance update period. The first acquisition interrogation is to be transmitted using the top antenna. If two acquisition interrogations to a target fail to elicit valid replies, the next two acquisition interrogations to that target are to be transmitted using the bottom antenna. If in the acquisition attempt in the first surveillance update period, valid replies are not received, ACAS transmits a total of nine acquisition interrogations distributed over the first six successive surveillance update periods. If acquisition interrogations fail to elicit replies within six surveillance update intervals, the acquisition process is to cease until enough additional squitters/fruit are received indicating that a successful acquisition is likely. One means of accomplishing this is to process subsequent squitters/fruit as described in 3.1.3.7, but with the increment 16 replaced by 8. If a second failure to acquire occurs, the process is repeated with an increment of 4. After any subsequent failure, an increment of 2 is used.

3.1.3.8.3 If additional attempts are made to acquire the target, they conform to the pattern described above except that:

- a) On the second and third attempt, only one interrogation is to be made during a single surveillance update interval; and in the absence of valid replies, six interrogations are to be transmitted during the first six surveillance update intervals.

- b) Any further attempts consist of a single interrogation during the entire six update intervals.

3.1.3.8.4 When a valid acquisition reply is received, the VS field in the reply is examined to determine the vertical status of a target. If a target is determined to be on the ground, its vertical status is periodically monitored by interrogating as often as necessary to ensure timely acquisition when airborne. When a valid acquisition reply is received from an airborne target, one or more interrogations are to be transmitted to the target within two surveillance update intervals in order to confirm the reliability of the altitude data and the altitude quantization bit. When two replies have been received from an airborne target that have altitude values within 150 m (500 ft) of each other and within 3 050 m (10 000 ft) of own altitude and have identical quantization bit values, periodic surveillance interrogations (designated as “tracking” interrogations) are to be initiated for that target.

3.1.3.8.5 The range of the target is used with its estimated range rate to determine its potential threat to ACAS. If the target is not an immediate potential threat, it can be interrogated less frequently than if it were a potential threat for which an advisory would soon most likely be issued. Each 1-second surveillance update interval, the potential threat level (*TAU*) of the target is calculated as follows:

$$TAU = -(r - SMOD^2/r)/\dot{r},$$

where  $r$  is the tracked range,  $\dot{r}$  is the estimated relative range rate and  $SMOD$  is a surveillance distance modifier which is equivalent to 5.6 km (3 NM). If the estimated relative range rate is either a negative value of less than  $-6$  kt or positive (either a slow convergence or the aircraft are diverging), the  $\dot{r}$  value used to calculate  $TAU$  is  $-6$  kt. An  $SMOD$  value of 5.6 km ensures that ACAS will always use the nominal 1-second interrogation cycle in situations where the value of  $TAU$  can change rapidly, such as in a parallel approach. A target with a  $TAU$  value of equal to or less than 60 seconds is interrogated at the nominal rate of once every second. A target with a  $TAU$  value greater than 60 seconds is interrogated at a rate of once every five seconds if the altitude of the target and own aircraft are both less than 5 490 m (18 000 ft) and at a rate of at least once every five seconds if the altitude of the target or own aircraft is greater than 5 490 m (18 000 ft).

### 3.1.3.9 MODE S SURVEILLANCE EXTENSION

3.1.3.9.1 The equipment passes position reports for a Mode S target to the collision avoidance algorithms only if all replies used for threat assessment after the initial range acquisition occur within range and altitude windows centred on range and altitude predicted from previous reply history, the altitude quantization bit matches the previous value, and the VS field in the short special surveillance reply indicates the target to be airborne at least once during the previous three surveillance update cycles. The range and altitude windows are the same as those used for Mode A/C tracking in 3.1.2.9.2 and 3.1.2.9.3 respectively.

3.1.3.9.2 If a tracking interrogation fails to elicit a valid reply, additional interrogations are transmitted. The total number of tracking interrogations addressed to a single target is not expected to exceed five during a single surveillance update period or sixteen distributed over six successive surveillance update periods. The first tracking interrogation is transmitted using the antenna that was used in the last successful interrogation of that target. If two successive tracking interrogations fail to elicit valid replies from a target, the next two interrogations to that target are transmitted using the other antenna.

3.1.3.10 *Missing Mode S replies.* The equipment continues to pass to the collision avoidance algorithms predicted position reports for Mode S targets for six surveillance update intervals following the receipt of the last valid reply to a tracking interrogation if the target is interrogated once every second or for eleven 1-second surveillance update intervals following receipt of the last valid reply to a tracking interrogation if the target is interrogated once every five seconds. The equipment does not pass position reports for Mode S targets for more than six surveillance update intervals following the receipt of the last reply to a tracking interrogation whose rate is once every second or for more than eleven 1-second surveillance update intervals following receipt of the last reply to a tracking interrogation whose rate is once every five seconds unless the target again satisfies the range acquisition criteria of 3.1.3.7. The Mode S address of a dropped track is retained for four additional seconds to shorten the reacquisition process if squitters are received.

3.1.3.11 *Mode S overload.* The equipment passes position reports for all Mode S targets regardless of the distribution of targets in range, provided the total peak target count does not exceed 30.

3.1.3.12 *Mode S power programming.* The transmit power level of Mode S tracking interrogations to targets (but not air-to-air coordination interrogations) is to be automatically reduced as a function of range for targets within 18.5 km (10 NM) as follows:

$$P_T = P_{\max} + 20 \log \frac{r}{10},$$

where  $P_T$  is the adjusted power level,  $P_{\max}$  is the nominal power level (typically 250 W), which is transmitted to targets at ranges of 18.5 km (10 NM) or more, and  $r$  is the predicted range of the target. The actual transmitted power is the lesser of  $P_T$  and the limit imposed by the interference limiting inequalities of Chapter 4, 4.3.2.2.2.2.

3.1.3.13 *Mode S track capacity.* When the aircraft density is nominally 0.087 Mode S aircraft per km<sup>2</sup> (0.3 aircraft per NM<sup>2</sup>) in the vicinity of the ACAS aircraft, there will be about 24 aircraft within 9.3 km (5 NM) and about 142 aircraft within 56 km (30 NM) of the ACAS aircraft. Thus, the ACAS equipment is expected to have capacity for at least 150 aircraft addresses.

#### 3.1.3.14 *USE OF BEARING ESTIMATES FOR MODE S SURVEILLANCE*

3.1.3.14.1 Bearing estimation capability is not required for high-density Mode S surveillance. However, if bearing estimates are available, it is seen that the use of directional Mode S interrogations significantly reduces the transmitter power requirement of the equipment. Directional Mode S interrogations may also be used in the absence of bearing information, provided the interference limits are not exceeded.

3.1.3.14.2 Bearing estimates may also be used in conjunction with knowledge of own airspeed to reduce the overall Mode S interrogation rate. The following is one possible way of achieving such a reduction.

3.1.3.14.3 Instead of calculating time-to-endanger based on the conservative assumption that the two aircraft are on a head-on collision course, the time-to-endanger can be increased by taking into account the threat bearing and the limited turn-rate of own aircraft and allowing for the time that would be required for own aircraft to turn in the direction of the threat. Such computation would continue to assume that the target aircraft is travelling at its reported maximum capable speed directly toward the collision point.

## 3.2 Transmitter

### 3.2.1 POWER LEVELS

3.2.1.1 In the absence of interference and when using an antenna whose pattern is identical to that of a quarter-wave monopole above a ground plane, it is possible to provide reliable air-to-air surveillance of transponders at ranges of 26 km (14 NM) by using a nominal effective radiated power of 54 dBm (250 W).

3.2.1.2 The transmitter output power is to be carefully limited between transmissions because any leakage may severely affect the performance of the Mode S transponder on board the ACAS aircraft. The leakage power into the transponder at 1 030 MHz is generally to be kept at a level below -90 dBm. If the physical separation between the transponder antenna and the ACAS antenna is no less than 50 cm, the coupling loss between the two antennas will exceed 20 dB. Thus, if the RF power at 1 030 MHz at the ACAS antenna terminal does not exceed -70 dBm in the inactive state, and if a minimum antenna spacing of

50 cm is adhered to, the direct interference from the ACAS antenna to the transponder antenna will not exceed  $-90$  dBm. This requirement is to ensure that, when not transmitting an interrogation, ACAS does not radiate RF energy that could interfere with, or reduce the sensitivity of, the SSR transponder or other radio equipment in nearby aircraft or ground facilities.

3.2.1.3 Measures must also be taken to ensure that direct 1 030 MHz leakage from the ACAS enclosure to the transponder enclosure is below  $-110$  dBm when the two units are mounted side-by-side in a typical aircraft installation.

3.2.1.4 It is expected that the ACAS equipment be tested side-by-side with Mode S transponders of equivalent classification to ensure that each unit meets its sensitivity requirements in the presence of transmitter leakage from the other.

### 3.2.2 CONTROL OF SYNCHRONOUS INTERFERENCE BY WHISPER-SHOUT

3.2.2.1 To control Mode A/C synchronous interference and facilitate ACAS operation in airspace with higher traffic densities, a sequence of interrogations at different power levels may be transmitted during each surveillance update period. Each of the interrogations in the sequence, other than the one at lowest power, is preceded by a suppression pulse (designated  $S_1$ ) 2 microseconds preceding the  $P_1$  pulse. The combination of  $S_1$  and  $P_1$  serves as a suppression transmission.  $S_1$  is transmitted at a power level lower than that of  $P_1$ . The minimum time between successive interrogations is to be 1 millisecond. All interrogations in the sequence should be transmitted within a single surveillance update interval.

3.2.2.2 Because the suppression transmission in each step is always at a lower power level than the following interrogation, this technique is referred to as whisper-shout. The intended mechanism is that each aircraft replies to only one or two of the interrogations in a sequence. A typical population of Mode A/C transponders at any given range may have a large spread in effective sensitivity due to variation in receivers, cable losses, and antenna shielding. Ideally, each transponder in the population will respond to two interrogations in the sequence, and will be turned off by the higher power suppression transmissions accompanying higher-power interrogations in the sequence. Given a situation in which several aircraft are near enough to each other in range for their replies to synchronously interfere, it is unlikely they would all reply to the same interrogation and, as a result, the severity of synchronous interference is reduced. Use of whisper-shout also reduces the severity of the effects of multipath on the interrogation link.

3.2.2.3 Figure A-2a defines a whisper-shout sequence that is matched to the requirements for high-density Mode A/C surveillance and Figure A-2b defines a whisper-shout sequence that is matched to the requirements for low-density Mode A/C surveillance. Five distinct subsequences are defined; one for each of the four beams of the top-mounted antenna and one for the bottom-mounted omnidirectional antenna. The interrogations may be transmitted in any order. When the high density sequence of Figure A-2a is truncated to limit interference, the steps are dropped in the order shown in the column Interference limiting priority. When the low-density sequence of Figure A-2b is reduced in power to limit interference, each interrogation and its related MTL value, as indicated in the last column, is reduced by 1 dB in the order shown in the column Interference limiting priority. The lowest numbered steps in the sequence are dropped or reduced first. The timing of individual pulses or steps in either sequence is defined in Figure A-3 which illustrates the three lowest-power steps in the top-forward antenna sequence. The first pulse of the interrogation serves as the second pulse of the suppression.

3.2.2.4 The minimum triggering level (MTL) values tabulated in Figure A-2a and Figure A-2b are based on the assumption that replies to all interrogations are received omnidirectionally. If a directional-receive antenna is used, the MTL values must be adjusted to account for the antenna gain. For example, for a net antenna gain of 3 dB, all MTL values in the table would be raised by 3 dB; and the MTL for step number 1 would be  $-71$  dBm rather than  $-74$  dBm.

3.2.2.5 The power is defined as the effective radiated power for the interrogation. All power levels are to be within  $\pm 2$  dB of nominal. The tolerance of the step increments is to be  $\pm 1/2$  dB and the increments are to be monotonic throughout the entire power range of the sequence.

3.2.2.6 Most of the interrogations are transmitted from the top antenna because it is less susceptible to multipath interference from the ground.

3.2.2.7 Selection of the appropriate whisper-shout subsequence for a particular antenna beam is performed each interrogation cycle based on the current or anticipated level of Mode A/C synchronous garble in that beam as determined by ACAS surveillance. The high density whisper-shout subsequence is selected for an antenna beam whenever synchronous garble is present in that beam as evident from the existence of at least one low confidence altitude code bit in two consecutive Mode C replies. The 6-level whisper-shout sequence is selected for an antenna beam if either:

- a) a single Mode A/C aircraft exists within the surveillance range of that beam and synchronous garble is not present; or
- b) synchronous garble is not present, Mode A/C targets are not within garble range of each other, and the Mode A/C aircraft density within the reliable surveillance range is equal to or less than 0.23 aircraft/km (0.43 aircraft/NM). Whenever a TA is generated on a threat within a particular antenna beam, the high level sequence is used for that beam for the duration of the advisory. Whenever an RA is generated, the high level sequence is used for all antenna beams for the duration of the advisory.

3.2.2.8 If no established Mode A/C surveillance track nor any candidate track, consisting of three correlating Mode C acquisition replies, exists within the surveillance range of an antenna beam, degarbling is unnecessary and ACAS transmits a single Mode C interrogation in that beam. The power level of the single interrogation and its associated MTL in each beam is equivalent to the highest allowable power level of the corresponding low level whisper-shout subsequence as determined by interference limiting. Single Mode C interrogations are susceptible to uplink mode conversion due to multipath and may result in a mixture of Mode A and Mode C replies from an intruder that are separated by 13 microseconds. ACAS, therefore, selects the low level whisper-shout subsequence for a beam for reliable surveillance acquisition and tracking whenever:

- a) a single interrogation in that beam results in a Mode A/C reply that occurs within a 1 525 m (5 000 ft) range window centred either at the measured range of a Mode A/C reply received in the previous surveillance update interval or at a range offset from the previous reply range by  $\pm 13$  microseconds; or
- b) an established Mode C track or a Mode C track in the process of being acquired traverses into that beam from another beam. ACAS switches back to the single interrogation after ten surveillance update intervals in which two correlating acquisition replies were not received.

### 3.2.3 INTERFERENCE LIMITING

3.2.3.1 ACAS equipment conforms to a set of three specific inequalities (Chapter 4, 4.3.2.2.2) for controlling interference effects. The three inequalities, applicable to ACAS operating below a pressure-altitude of 5 490 m (18 000 ft), are associated with the following physical mechanisms: (1) reduction in “on” time of other transponders caused by ACAS interrogations, (2) reduction in “on” time of own transponder caused by mutual suppression during transmission of interrogations, and (3) Mode A/C fruit caused by ACAS Mode A/C interrogations. Setting  $n_a$  to 1 in inequalities (1) and (3) for ACAS operating above pressure-altitude of 5 490 m (18 000 ft), prevents a single ACAS from transmitting unlimited power by providing an upper limit on the ACAS one-second interrogation power/rate product.

3.2.3.2 Inequality (1) ensures that a “victim” transponder will never detect more than 280 ACAS interrogations in a one-second period from all the ACAS interrogators within 56 km (30 NM) for any ACAS distribution, surrounding the “victim” transponder, within the limits of uniform-in-range to uniform-in-area. The left-hand side of the inequality allows an ACAS unit to increase its interrogation rate if it transmits at less than 250 W since low power transmissions are detected by fewer transponders. Each normalized power value within the summation in the left-hand side of this inequality contains an exponent  $\alpha$  which serves to match the inequality to the localized ACAS distribution. The value of  $\alpha$  defines the local ACAS aircraft distribution curve and is derived from own ACAS measurement of the distribution and number of other ACAS within 56 km (30 NM) range. As the ACAS distribution varies from uniform-in-area ( $\alpha = 1$ ) to uniform-in-range ( $\alpha = 0.5$ ), the density, and therefore the electromagnetic impact, of ACAS aircraft in the vicinity of a “victim” transponder becomes greater. This increased potential for ACAS interference is offset by the greater degree of interference limiting that results from using an exponent of less than one in the normalized power values of the inequality. The denominator of the first term on the right-hand

side of this inequality accounts for other ACAS interrogators in the vicinity and the fact that all ACAS units must limit their interrogation rate and power in a similar manner so that, as the number of ACAS units in a region increases, the interrogation rate and power from each of them decreases and the total ACAS interrogation rate for any transponder remains less than 280 per second.

3.2.3.3 Within an airspace in which ACAS aircraft are distributed between the limits of uniform-in-range to uniform-in-area, and provided that the “victim” is taken off the air for 35 microseconds by suppression or reply dead time whenever it receives an ACAS interrogation, the total “off” time caused by ACAS interrogations will then never exceed 1 per cent. Measurements and simulations indicate that the total “off” time can be higher than 1 per cent in high-density terminal areas because of ACAS aircraft distributions that are beyond the region defined by uniform-in-area to uniform-in-range and because of a Mode S transponder recovery time to certain interrogations that is expected to be greater than 35 microseconds. The second term on the right-hand side of this inequality limits the maximum value of the interrogation power-rate product for ACAS II, regardless of  $n_a$ , in order to allow a portion of the total interference limiting allocation to be used by ACAS I. The term, which is matched to the ACAS distribution by the value of  $\alpha$  in the denominator, ensures that an individual ACAS II unit never transmits more average power than it would if there were approximately 26 other ACAS II nearby distributed uniformly-in-area or approximately 6 other ACAS II nearby distributed nearly uniformly-in-range.

3.2.3.3.1 High-density terminal areas will suffer from higher loads due to violation of the 1 per cent estimate at approximately 14.8 – 18.5 km (8 – 10 NM) from touch down. To ensure sufficient surveillance performance for both ACAS and ground surveillance systems in such areas, ACAS flying below 610 m (2 000 ft) AGL include also ACAS II and ACAS III operating on ground in the calculation of  $n_b$  and  $n_c$ . This value was chosen for practical reasons:

- a) the use of a radio altimeter allows sufficient measurement accuracy at and below 610 m (2 000 ft); and
- b) it assumes aircraft are approaching on an ILS glide path. In that case, 610 m (2 000 ft) AGL corresponds to a distance of approximately 11.2 km (6 NM) from an airport.

New approach procedures (e.g. based on MLS or GNSS) may require additional considerations to limit interference. And even with ILS approach, it is recommended to establish procedures switching ACAS II and ACAS III to “stand-by” while the aircraft is not on an active runway.

3.2.3.4 Inequality (2) ensures that the transponder on board the ACAS aircraft will not be turned off by mutual suppression signals from the ACAS unit on the same aircraft more than 1 per cent of the time.

3.2.3.5 Inequality (3) ensures that a “victim” Mode A/C transponder will not generate more than 40 Mode A/C replies in a one-second period in response to interrogations from all the ACAS interrogators within its detection range. Like inequality (1) it includes terms to account for reduced transmit power, to account for the other ACAS interrogators in the vicinity, and to limit the power of a single ACAS unit. Forty Mode A/C replies per second is approximately 20 per cent of the reply rate for a transponder operating without ACAS in a busy area of multiple Mode A/C ground sensor coverage.

#### 3.2.3.6 EXAMPLE OF INTERFERENCE LIMITING

3.2.3.6.1 As an example, when interrogation limiting is not invoked, the overall Mode A/C and Mode S interrogation rates of a directional ACAS unit would typically be as follows: the Mode A/C interrogation rate  $k_i$  is typically constant at 83 whisper-shout interrogations per second. Assume that the sum of the normalized whisper-shout powers, i.e. the Mode A/C contribution to the left-hand side of inequality (1), is approximately 3. The Mode S interrogation rate depends on the number of Mode S aircraft in the vicinity. In en-route airspace it is typically an average of about 0.08 interrogations per second for each Mode S aircraft within 56 km (30 NM). In a uniform aircraft density of 0.006 aircraft per square km (0.02 aircraft per square NM), the number of aircraft within 56 km (30 NM) is 57. If 20 per cent of these are ACAS equipped,  $n_a = 12$  and the variable term on the right-hand side of inequality (1) is 21.5. If the number of ACAS aircraft in the area does not exceed 26, the fixed term continues to govern and no limiting occurs until there are approximately 100 Mode S aircraft within 56 km (30 NM).



3.2.3.6.2 Similar considerations hold for inequalities (2) and (3). In inequality (2) the mutual suppression interval associated with each top antenna interrogation is 70 microseconds. The bottom antenna mutual suppression interval is 90 microseconds. Thus the Mode A/C contribution to the left-hand side of inequality (2) is 0.0059 and the Mode S interrogation rate can be as high as 59 top antenna interrogations per second before violating the limit. With a typical whisper-shout sequence, the left-hand side of inequality (3) is approximately 3. The number of ACAS aircraft within 56 km (30 NM) can be as high as 26 without violating inequality (3).

3.2.3.6.3 When the interrogation rate or density increases to the point at which one of the limits is violated, either the Mode A/C or Mode S normalized interrogation rate or both must be reduced to satisfy the inequality. If the density were to reach 0.029 aircraft per km<sup>2</sup> (0.1 aircraft per NM<sup>2</sup>) uniformly out to 56 km (30 NM), there would be 283 aircraft within a 56 km (30 NM) radius. If 10 per cent of these were equipped with ACAS,  $n_a = 28$ . The right-hand limits in inequalities (1) and (3) would then be 9.66 and 2.76 respectively. To satisfy these lower limits, the Mode A/C and Mode S contributions to the left-hand side of inequality (1) would both have to be reduced. As a result, the surveillance range of both Mode A/C and Mode S targets would be less.

3.2.3.6.4 Inequality (1) contains an exponent  $\alpha$  which serves to match the inequalities to the specific local ACAS aircraft density such that a “victim” transponder operating in the vicinity of ACAS that are distributed within the limits of uniform-in-area to uniform-in-range will never detect more than 280 ACAS interrogations in a one-second period.

The value of  $\alpha$  defines the local ACAS distribution characteristic within the vicinity of own ACAS.

It is based on the relative numbers of ACAS within 56 km (30 NM), within 11.2 km (6 NM) and within 5.6 km (3 NM) as derived from ACAS broadcast interrogations and from ACAS surveillance. The value of  $\alpha$  is the minimum of:

- a) the logarithm of the ratio of the number of ACAS aircraft,  $n_a$ , within 56 km (30 NM) to the number of ACAS aircraft,  $n_b$ , within 11.2 km (6 NM) divided by the logarithm of 25; and
- b) one fourth of the ratio of the number of ACAS aircraft,  $n_b$ , within 11.2 km (6 NM) to the number of ACAS aircraft,  $n_c$ , within 5.6 km (3 NM).

A uniform-in-area distribution of ACAS aircraft within 56 km results in an  $\alpha$  value of 1.0 and a uniform-in-range distribution results in a value of 0.5. Since decreasing values of  $\alpha$  result in greater power reduction and therefore shorter surveillance ranges, the minimum value of  $\alpha$  is constrained to 0.5 in order to preserve adequate surveillance range for collision avoidance in the highest density terminal areas. Additional constraints are imposed on the value of  $\alpha_1$  to account for special situations in which the measured local ACAS distribution is:

- 1) based on numbers so small as to be inconclusive ( $n_b = 1$ ), in which case  $\alpha_1$  is constrained to 1;
- 2) is inconsistent with a relatively high overall ACAS count ( $n_b \leq 4$ ,  $n_c \leq 2$ ,  $n_a > 25$ ), in which case  $\alpha_1$  is constrained to 1; or
- 3) is inconsistent with a relatively low overall ACAS count, ( $n_c > 2$ ,  $n_b > 2n_c$ ,  $n_a < 40$ ), in which case  $\alpha_1$  is constrained to 0.5.

### 3.2.3.7 INTERFERENCE LIMITING PROCEDURES

3.2.3.7.1 At the beginning of each surveillance update interval,  $n_a$ ,  $n_b$  and  $n_c$  are to be determined as indicated above.  $n_a$  is then used to evaluate the current right-hand limits in inequalities (1) and (3). Smoothed values of the Mode S variables in the inequalities are also to be calculated.

$n_b$  and  $n_c$  are used to compute the value of  $\alpha_1$  according to the following expression:

$$\alpha_1 = 1/4 [n_b/n_c]$$

$n_a$  and  $n_b$  are used to compute the value of a  $\alpha_2$  according to the following expression:

$$\alpha_2 = \frac{\text{Log}_{10}[n_a/n_b]}{\text{Log}_{10}25}$$

In addition:

IF [ $(n_b \leq 1)$  OR  $(n_b > 4n_c)$  OR  $(n_b \leq 4$  AND  $n_c \leq 2$  AND  $n_a > 25)$ ] THEN  $\alpha_1 = 1.0$ ;

IF [ $(n_b < 2n_c)$  OR  $((n_c > 2)$  AND  $(n_b > 2n_c)$  AND  $(n_a < 40))$ ] THEN  $\alpha_1 = 0.5$ ;

IF  $(n_a > 25n_b)$  THEN  $\alpha_2 = 1.0$ ;

IF  $(n_a < 5n_b)$  THEN  $\alpha_2 = 0.5$ ;

the value of  $\alpha$  is the minimum of  $\alpha_1$  and  $\alpha_2$ .

3.2.3.7.2 All air-to-air coordination interrogations and RA and ACAS broadcast interrogations are transmitted at full power. Air-to-air coordination interrogations and RA and ACAS broadcast interrogations are not included in the summations of Mode S interrogations in the left-hand terms of these inequalities. Whenever an RA is posted, surveillance interrogations to that intruder may be transmitted at full power to allow for maximum link reliability. Because the frequency of RAs is very low, these transmissions do not result in a measurable increase in interference.

3.2.3.7.3 If the smoothed value of the left-hand side of either inequality (1) or (2) equals or exceeds the current limit and own ACAS aircraft are operating below a pressure-altitude of 5 490 m (18 000 ft), both the Mode S and Mode A/C surveillance parameters are to be modified to satisfy the inequalities. If the left-hand side of inequality (3) exceeds the current limit and own ACAS aircraft are operating below a pressure-altitude of 5 490 m (18 000 ft), Mode A/C surveillance parameters are modified to satisfy the inequalities.

3.2.3.7.4 Mode A/C surveillance can be modified by sequentially eliminating steps from the whisper-shout sequence described in 3.2.2. Each whisper-shout step is uniquely associated with a receiver MTL setting. Thus, the receiver sensitivity in Mode A/C surveillance periods will be automatically tailored to match these power reductions.

3.2.3.7.5 The overall surveillance sensitivity for Mode S targets can be reduced by reducing the interrogation power and by increasing the receiver MTL during all Mode S squitter listening periods. This will indirectly reduce the Mode S interrogation rate by reducing the target count. Many Mode S interrogations are acquisition interrogations transmitted to targets of unknown range. It is thus not effective to directly control the Mode S interrogation rate simply by dropping long-range targets from the track file.

3.2.3.7.6 For airborne ACAS, the Mode A/C and Mode S surveillance power and sensitivity reductions are to be accomplished such that equality between the surveillance ranges for Mode S and Mode A/C targets exists in the forward beam. In order to provide a reliable 11.2 km (6 NM) surveillance range in all directions for  $n_b$ , the maximum allowed interference limiting power reduction in any beam for an airborne ACAS unit is 10 dB for Mode S and 7 dB for Mode A/C. Mode A/C surveillance power and sensitivity reductions for ACAS on the ground are to be accomplished such as to achieve equal whisper-shout capability in each beam. This requires that Mode A/C power and sensitivity reduction be accomplished in the forward beam until it is equivalent to the side beams and then in the forward and side beams until they are equivalent to the rear beam. In order to provide a reliable 5.6 km (3 NM) surveillance range in all directions for surveillance prior to departure, the maximum allowed interference limiting power reduction for an ACAS unit on the ground is as follows:

- a) forward beam: 13 dB for Mode S and 10 dB for Mode A/C;
- b) side beam: 13 dB for Mode S and 6 dB for Mode A/C; and
- c) rear beam: 13 dB for Mode S and 1 dB for Mode A/C.

In addition, the Mode A/C and Mode S surveillance power and sensitivity reductions for ACASs that are airborne or on the ground are to be accomplished such that the ACAS equipment is not prematurely limited and has the capability of using at least 75 per cent of the allowance specified in the three limiting equations for all mixes of target types and for all densities up to the maximum density capability of the system. When the value of any of the smoothed limits is exceeded, the appropriate action is required to limit interference within one surveillance update interval. Means are to be provided for gradually restoring the surveillance sensitivity when the environment subsequently improves enough to allow the interference limits to be relaxed.

3.2.3.7.7 ACAS cross-link interrogations are included in the summation of Mode S interrogations in the left-hand terms of the interference limiting inequalities.

### 3.2.3.8 IMPLEMENTATION OF A TYPICAL INTERFERENCE LIMITING PROCEDURE

3.2.3.8.1 The following describes one possible implementation of an interference limiting procedure. It varies the system parameters appearing in inequalities (1), (2) and (3) to maximize and maintain approximate equality between the estimated surveillance ranges for Mode S and Mode A/C targets. In evaluating these inequalities, 8-second averages of the Mode S parameters are used, and current or anticipated values of the Mode A/C parameters are used. The procedure is illustrated in the flow chart of Figure A-4.

3.2.3.8.2 *Step 1.* The first step in the control process is to reduce the number of whisper-shout steps tentatively scheduled for use during the present scan if either:

- a) inequality (3) is violated; or
- b) inequality (1) or (2) is violated and the Mode S surveillance range of the last scan does not exceed the Mode A/C surveillance range that would result from use of the scheduled whisper-shout sequence.

Whisper-shout steps are eliminated in the order dictated by the design of the Mode A/C processor and the number of steps eliminated is just large enough to ensure that neither of the above conditions is satisfied. The value of the number of whisper-shout steps tentatively scheduled for use is initialized at the number used on the last scan.

The relative magnitudes of the Mode S and Mode A/C surveillance ranges are determined from the estimated effective radiated power (ERP) seen by targets with Mode S and Mode A/C transponders located directly ahead of the ACAS aircraft. The ERP in a given direction is determined by the product of the power input to the antenna, and the antenna pattern gain in that direction. If the transponder sensitivities were identical, the Mode S range would be more or less than the Mode A/C range according to whether the Mode S transmitted power was more or less than the Mode A/C transmitted power. Since Mode A/C transponders may have somewhat lower sensitivities than Mode S transponders, the Mode A/C range is assumed to be greater than the Mode S range if, and only if, the Mode A/C power exceeds the Mode S power by 3 dB.

3.2.3.8.3 *Step 2.* The second step in the controlling process is to reduce the Mode S interrogation power for acquisition by 1 dB, and to increase the MTL for Mode S squitter listening by 1 dB from the values last used, if inequality (1) or (2) is violated and the Mode S surveillance range of the last scan exceeds the Mode A/C surveillance range that would result from use of the scheduled whisper-shout sequence.

Once such a change has been made, the only change allowed during the ensuing 8 seconds is a reduction in the number of whisper-shout steps if needed to satisfy inequality (3). This 8-second freeze allows the effect of the Mode S changes to become apparent since the 8-second averages used in inequalities (1) and (2) then will be determined by the behaviour of the system since the change.

3.2.3.8.4 *Step 3.* The third step is to add a whisper-shout step to those tentatively scheduled, when it is not prevented by an 8-second freeze, and the following conditions are satisfied:

- a) inequalities (1), (2) and (3) are satisfied and will continue to be satisfied after the step is added; and

- b) the Mode S surveillance range of the last scan exceeds the Mode A/C surveillance range that would result from use of the scheduled sequence; and

As many steps are added as possible without violating a) or b) above.

3.2.3.8.5 *Step 4.* Finally, if condition a) of 3.2.3.8.4 above is satisfied, but condition b) is not, an estimate is made of the effects of increasing the Mode S interrogation power for acquisition by 1 dB and reducing the MTL for Mode S squitters/fruit by 1 dB. If the estimate indicates that inequalities (1) and (2) will not continue to be satisfied, the 1 dB change is not made. If the estimate indicates that they will continue to be satisfied, the 1 dB change is made and no further changes in either the Mode A/C or Mode S parameters are made for the ensuing 8 seconds, except as described in 3.2.3.8.3 above.

### 3.2.4 INTERROGATION JITTER

Mode A/C interrogations from ACAS equipment are intentionally jittered to avoid chance synchronous interference with other ground-based and airborne interrogators. It is not necessary to jitter the Mode S surveillance interrogations because of the inherently random nature of the Mode S interrogation scheduling process for ACAS.

## 3.3 Antennas

### 3.3.1 USE OF DIRECTIONAL INTERROGATIONS

3.3.1.1 A directional antenna is recommended for reliable surveillance of Mode A/C targets in aircraft densities up to 0.087 aircraft per square km (0.3 aircraft per square NM). The recommended antenna system consists of a four-beam antenna mounted on top of the aircraft and an omnidirectional antenna on the bottom. A directional antenna may also be used instead of the omnidirectional antenna on the bottom of the aircraft. The directional antenna sequentially generates beams that point in the forward, aft, left, and right directions. Together these provide surveillance coverage for targets at all azimuth angles without the need for intermediate pointing angles.

3.3.1.2 The directional antenna typically has a 3-dB beam width (BW) in azimuth of  $90 \pm 10$  degrees for all elevation angles between +20 and -15 degrees. The interrogation beamwidth is to be limited by transmission of a  $P_2$  side-lobe suppression pulse following each  $P_1$  interrogation pulse by 2 microseconds. The  $P_2$  pulse is transmitted on a separate control pattern (which may be omnidirectional).

3.3.1.3 There is need for timely detection of aircraft approaching with low closing speeds from above and below. Detection of such aircraft suggests a need for sufficient antenna gain within a  $\pm 10$  degree elevation angle relative to the ACAS aircraft pitch plane. An ACAS directional antenna typically has a nominal 3 dB vertical beamwidth of 30 degrees.

3.3.1.4 The shape of the directional antenna patterns and the relative amplitude of the  $P_2$  transmissions is controlled such that a) a maximum suppression transponder located at any azimuth angle between 0 and 360 degrees and at any elevation angle between +20 and -15 degrees would reply to interrogations from at least one of the four directional beams and b) a minimum suppression transponder would reply to interrogations from no more than two adjacent directional beams. A maximum suppression transponder is defined as one that replies only when the received ratio of  $P_1$  to  $P_2$  exceeds 3 dB. A minimum suppression transponder is defined as one that replies when the received ratio of  $P_1$  to  $P_2$  exceeds 0 dB.

3.3.1.5 The effective radiated power (ERP) from each antenna beam (forward, left, right, aft, omni) is expected to be within  $\pm 2$  dB of its respective nominal value as given in Figure A-2a.

3.3.1.6 A forward directional transmission, for which TRP = 49 dBm and BW =  $90^\circ$  has a power gain product at beam centre of approximately,

$$PG = \frac{TRP}{BW/360^\circ} = 55 \text{ dBm}$$

This is 1 dB greater than the nominal and allows for adequate coverage at the cross-over points of the directional beams. The TRP of the side and aft beams is reduced relative to the front beam to account for the lower closing speeds that occur when aircraft approach from these directions. Mode A/C surveillance performance will generally improve as the directivity (and hence the number of beams) is increased for the top-mounted antenna. However, the use of a directional antenna on the bottom would provide only marginal improvement in detectability and would, if used at full power, degrade the overall performance of the equipment by increasing the false track rate due to ground-bounce multipath.

### 3.3.2 DIRECTION FINDING

The angle-of-arrival of the transmissions from the replying transponders can be determined with better than 10-degree RMS accuracy by means of several simple and practical direction-finding techniques. These techniques typically employ a set of four or five monopole radiating elements mounted on the aircraft surface in a square array with quarter-wave spacing. The signals from these elements may be combined so as to generate from two to four distinct beams which may be compared in phase or amplitude to provide an estimate of the direction of arrival of the received signal. This level of direction-finding accuracy is adequate to provide the pilot with TAs to effectively aid the visual acquisition of intruding aircraft.

### 3.3.3 DIRECTIONAL TRANSMISSION FOR CONTROL OF SYNCHRONOUS GARBLE

3.3.3.1 The use of directional interrogation is one technique for reducing synchronous garble. The directional interrogation can reduce the size of the interrogation region. Coverage must be provided in all directions. Hence, multiple beams are used to elicit replies from all aircraft in the vicinity of the ACAS-equipped aircraft. Care must be taken to overlap the beams so that gaps in coverage do not exist between beams.

3.3.3.2 The antenna may be a relatively simple array capable of switching among typically four or eight discrete beam positions. For four beam positions, the antenna beamwidth is expected to be on the order of  $100^\circ$ . The effective antenna beamwidth for interrogating Mode A/C transponders can be made more narrow than the 3-dB beamwidth by means of transmitter side-lobe suppression.

### 3.3.4 ANTENNA LOCATION

The top-mounted directional antenna is to be located on the aircraft centre line and as far forward as possible. The ACAS antennas and the Mode S transponder antennas are to be mounted as far apart as possible on the airframe to minimize coupling of leakage energy from unit to unit. The spacing must never be less than 0.5 m (1.5 ft), as this spacing results in a coupling loss of at least 20 dB.

## 3.4 Receiver and processor

### 3.4.1 SENSITIVITY

A sensitivity equivalent to that of a Mode S transponder (minimum triggering level of  $-74$  dBm) will provide adequate link margin to provide reliable detection of near co-altitude aircraft in level flight at a range of 26 km (14 NM) provided those aircraft are themselves equipped with transponders of nominal transmit power.

### 3.4.2 CONTROL OF RECEIVER THRESHOLD

3.4.2.1 ACAS receivers use a variable (dynamic) threshold to control the effects of multipath. When the first pulse of a reply is received, the variable receiver threshold technique raises the receiver threshold from the minimum triggering level (MTL) to a level at a fixed amount (e.g. 9 dB) below the peak level of the received pulse. The receiver threshold is maintained at this level for the duration of a Mode A/C reply, at which time it returns to the MTL. When multipath returns are weak compared to the direct-path reply, the first pulse of the direct-path reply raises the receiver threshold sufficiently so that the multipath returns are not detected.

3.4.2.2 Variable receiver thresholds have historically been avoided in Mode A/C reply processors because such thresholding tends to discriminate against weak replies. However, when used in conjunction with whisper-shout interrogations, this disadvantage is largely overcome. On any given step of the interrogation sequence it is possible for a strong reply to raise the threshold and cause the rejection of a weaker overlapping reply. However, with whisper-shout interrogations, the overlapping replies received in response to each interrogation are of approximately equal amplitudes since the whisper-shout process sorts the targets into groups by signal strength.

3.4.2.3 The ACAS receiver MTL used in the reply listening period following each whisper-shout interrogation relates to the interrogation power in a prescribed manner. In particular, less sensitive MTLs are used with the lower interrogation powers in order to control the Mode A/C fruit rate in the ACAS receiver while still maintaining a balance between the interrogation link and the reply link so that all elicited replies are detected.

### 3.4.3 PULSE PROCESSING

3.4.3.1 A relatively wide dynamic range receiver faithfully reproduces the received pulses. Provisions may be included for locating the edges of received pulses with accuracy, and logic may be provided for eliminating false framing pulses that are synthesized by code pulses from real replies. The processor is capable of resolving pulses in situations where overlapped pulse edges are clearly distinguishable. It is also capable of reconstructing the positions of hidden pulses when overlapping pulses of nearly the same amplitude cause the following pulses to be obscured. The reply processor has the capacity for handling and correctly decoding at least three overlapping replies. Means are also provided for rejecting out-of-band signals and for rejecting pulses with rise times exceeding 0.5 microsecond (typically, DME pulses).

3.4.3.2 If a Mode S reply is received during a Mode C listening period, a string of false Mode C fruit replies may be generated. The ACAS equipment is expected to reject these false replies.

### 3.4.4 ERROR DETECTION AND CORRECTION

3.4.4.1 ACAS avionics intended for use in airspace characterized by closing speeds greater than 260 m/s (500 kt) and densities greater than 0.009 aircraft per km<sup>2</sup> (0.03 aircraft per NM<sup>2</sup>) or closing speeds less than 260 m/s (500 kt) and densities greater than 0.04 aircraft per km<sup>2</sup> (0.14 aircraft per NM<sup>2</sup>) requires a capability for Mode S reply error correction. In these high densities, error correction is necessary to overcome the effects of Mode A/C fruit. Mode S error correction permits successful reception of a Mode S reply in the presence of one overlapping Mode A/C reply.

3.4.4.2 Error correction decoding is to be used for the following replies: DF = 11 all-call replies, DF = 0 short air-air surveillance replies, and DF = 16 long air-air surveillance replies (both acquisition and non-acquisition). In addition, passive monitoring of DF = 4 short surveillance altitude replies requires error correction decoding.

3.4.4.3 If two or more acquisition replies requiring error correction are received within the Mode S range acquisition window, it may be impractical to apply error correction to more than the first received reply. Acquisition replies other than the first do not need to be corrected when this occurs.

### 3.4.5 RECEIVER SIDE-LOBE SUPPRESSION

ACAS equipment that interrogates directionally may use receiver side-lobe suppression techniques to eliminate replies (fruit) generated by nearby aircraft that are outside the interrogated sector. This reduces the number of replies processed during the surveillance update period.

### 3.4.6 DUAL MINIMUM TRIGGERING LEVELS

If the MTL of the receiver used by ACAS is lowered to obtain longer range operation with extended squitter, provision must be made to label squitter receptions that were received at the MTL that would have been used by an unmodified ACAS receiver. Squitter receptions that are received at the conventional MTL or higher are fed to the ACAS surveillance function. Squitter receptions that are received below the conventional MTL are not used for ACAS surveillance but are routed directly to the extended squitter application. This filtering by MTL is necessary to prevent ACAS from attempting to interrogate aircraft that are beyond the range of its active surveillance capability. This would increase the ACAS interrogation rate without providing any improved surveillance performance. Use of the conventional MTL for the ACAS surveillance function preserves the current operation of ACAS surveillance when operating with a receiver with an improved MTL.

## 3.5 Collision avoidance algorithms

*Note.— The guidance material on the collision avoidance logic of ACAS II is organized in two sections. This section addresses the Standards in the ACAS SARPs and elaborates on important concepts using the design features of a specific implementation of the ACAS logic as examples. Section 4 provides further details on the algorithms and parameters used by this particular ACAS implementation. As a consequence of this arrangement, paragraphs in this section often refer to paragraphs in the next one.*

### 3.5.1 GENERAL

3.5.1.1 The ACAS algorithms operate in a cycle repeated nominally once per second. At the beginning of the cycle, surveillance reports are used to update the tracks of all intruders and to initiate new tracks as required. Each intruder is then represented by a current estimate of its range, range rate, altitude, altitude rate, and perhaps, its bearing. Own aircraft altitude and altitude rate estimates are also updated.

3.5.1.2 After the tracks have been updated, the threat detection algorithms are used to determine which intruders are potential collision threats. Two threat levels are defined: potential threat and threat. Potential threats warrant TAs while threats warrant RAs.

3.5.1.3 The resolution algorithms generate an RA intended to provide vertical separation from all threats identified by the threat-detection algorithms. Coordination with each equipped threat occurs as part of the process of selecting the RA. Pairwise coordination with each equipped threat is necessary to establish which aircraft is to pass above the other and thus guarantee avoidance manoeuvres that are compatible.

### 3.5.2 THREAT DETECTION

3.5.2.1 Collision threat detection is based on simultaneous proximity in range and altitude. ACAS uses range rate and altitude rate data to extrapolate the positions of the intruder and own aircraft. If within a short time interval (e.g. 25 seconds hence) the range of the intruder is expected to be “small” and the altitude separation is expected to be “small”, the intruder is declared a threat. Alternatively, the threat declaration may be based on current range and altitude separations which are “small”.

The algorithm parameters which establish how far into the future positions are extrapolated, and which establish thresholds for determining when separations are “small”, are selected in accordance with the sensitivity level at which the threat detection algorithms are operating.

3.5.2.2 Each sensitivity level defines a specific set of values for the detection parameters used by the algorithms. These include threshold values for the predicted time to closest approach, the minimum slant range, and the vertical separation. Through the process of sensitivity level control, these parameters are assigned different values to account for the smaller aircraft separations that occur in dense terminal airspace. Sensitivity level may be selected automatically using the altitude of own aircraft, or may be selected by command from a Mode S ground station, or by a manual pilot switch (see 3.5.12).

3.5.2.3 The values used for threat detection parameters cannot be optimum for all situations because ACAS is handicapped by its lack of knowledge of intruder intent. The result is that a balance has to be struck between the need to give adequate warning of an impending collision and the possible generation of unnecessary alerts. The latter may result from encounters that are resolved at the last moment by intruder manoeuvres. A feature of ACAS that helps in this respect is the variability of the protected volume of airspace. This volume is automatically coupled in size to the relative speed between the two aircraft, and is automatically aligned in a direction parallel to the relative velocity vector. Bearing plays no part in this process. Each encounter gives rise to a protected volume tailored to that encounter. In a multi-aircraft situation there is an individual protected volume for the ACAS aircraft paired with each threat.

### 3.5.3 PROTECTED VOLUME

An intruder becomes a threat when it penetrates a protected volume enclosing own aircraft. The protected volume is defined by means of a range test (using range data only) and an altitude test (using altitude and range data). Application of these tests delivers a positive or a negative result (implying that the threat is inside or outside the appropriate part of the protected volume). An intruder is declared a threat when both tests give a positive result.

#### 3.5.3.1 PROTECTED VOLUME TERMS' DESCRIPTION

*Collision plane.* The plane containing the range vector and the instantaneous relative velocity vector originating at the intruder.

*Critical cross-sectional area.* The maximum cross-sectional area of the protected volume in a plane orthogonal to the major axis.

*Instantaneous relative velocity(ies).* The modulus of the current value of relative velocity.

*Linear miss distance ( $m_a$ ).* The minimum value that range will take on the assumption that both the intruder and own aircraft proceed from their current positions with unaccelerated motions.

*Linear time to closest approach ( $t_a$ ).* The time it would take to reach closest approach if both the intruder and own aircraft proceed from their current positions with unaccelerated motions.

Given that the only information available to ACAS to make range predictions are range and range rate estimates, both the linear miss distance and the linear time to closest approach are unobservable quantities.

The unobservable quantities, linear miss distance and linear time to closest approach, are related to the observable quantities range  $r$  and range rate  $\dot{r}$  by the following equality:

$$t_a = \frac{(r^2 - m_a^2)}{(-r\dot{r})}$$



*Major axis.* In the context of the protected volume, the line through the ACAS II aircraft which is parallel to the instantaneous relative velocity vector.

*Range convergence.* The aircraft is deemed to be converging in range if the range rate is less than or equal to zero.

### 3.5.4 RANGE TEST

3.5.4.1 The protected volume resulting from the range test used in the ACAS implementation described in Section 4 can be defined in terms of the maximum dimensions of a realizable implementation of the test which is illustrated by Figure A-5. This shows a section through the protected volume generated by a range test in the plane containing both aircraft and the instantaneous relative velocity vector. The protected volume is that which would be produced by rotating the solid curve about the  $x$  axis. Note that the length of the major axis is a function of the relative speed,  $s$ . For the realizable range test, the radius of the maximum cross section through the protected volume in a plane normal to the instantaneous relative velocity vector is  $m_c$ . This represents the maximum miss distance for which an alert can be generated if the relative velocity at the time of entry to the protected volume is maintained to closest approach. The length of the major axis is the principal feature determining warning time while  $m_c$  controls the projected miss distance which is likely to generate an alert. Ideally, the warning time would be  $T$  seconds and  $m_c$  would be such that only intruders projected to have miss distances less than  $D_m$  (the radius of the broken-line circle in Figure A-5) would qualify for an alert. The significance of  $D_m$ , when specified as in the ACAS implementation described in Section 4, is that, to a good approximation, it represents the lateral displacement experienced by an aircraft over the time  $T$  when turning with a constant acceleration of  $g/3$  (bank angle =  $18^\circ$ ). Thus an encounter with a projected miss distance of  $D_m$  when the time to closest approach is  $T$  can result in a collision if either aircraft is manoeuvring with an acceleration of  $g/3$ . In the absence of adequate bearing rate or range acceleration data, ACAS cannot achieve the ideal. Figure A-6 shows the maximum value for  $m_c$  (i.e.  $\hat{m}_c$  as a function of relative speed and sensitivity level). When the relative speed is very low, as can occur in a tail-chase, the protected volume produced by the range test becomes a sphere of radius  $D_m$  centred on the ACAS aircraft.

3.5.4.2 Essentially, the range test gives a positive result if, when approximately  $T$  seconds remain before closest approach, the relative velocity vector can be projected to pass through a circle of radius  $m_c$  centred on the ACAS aircraft and placed in the plane normal to the relative velocity vector. Since the value of  $m_c$  is very large compared to the value for adequate vertical separation, the use of the range test alone would generate a large number of unnecessary alerts. It is therefore necessary to tailor the range test protected volume to more modest proportions using altitude data. Inevitably, this reduces the immunity to manoeuvres in the vertical plane.

3.5.4.3 The constraints on the range test are designed to give a nominal warning time of  $T$  seconds allowing for a manoeuvre producing a displacement of  $D_m$  normal to the relative velocity vector. It may be demonstrated that, for an encounter having a reasonably large relative velocity, the relative acceleration produced by a turning aircraft is nearly normal to the relative velocity vector. For low relative speed there can be a substantial component of acceleration in the direction of a relative velocity. Erosion of the warning time due to this component is compensated by having a minimum length for the major axis of the protected volume which is greater than  $sT$ .

### 3.5.5 ALTITUDE TEST

3.5.5.1 The objective of the altitude test is to filter out intruders that give a positive result for the range test but are nevertheless adequately separated in the vertical dimension. The altitude test is used to reduce alert rate in the knowledge that the standard vertical separation distances for aircraft are normally much less than the standard horizontal separation distances. An inevitable result is that the acceleration protection, nominally provided by the range test in all planes, is largely restricted to the horizontal plane. Also, even in the absence of relative acceleration, the altitude test can delay warnings if some vertical separation at closest approach is predicted to exist. A view in elevation of the relative motion of two aircraft is shown in Figure A-7. AOB represents a plane normal to the relative velocity vector and containing the ACAS aircraft. The intruder may be horizontally displaced from the ACAS so it is not necessarily in the plane of the diagram. The essential feature of the altitude test is that it aims to give a positive result if the projected vertical miss distance is less than  $Z_m$ . In the ACAS implementation described in Section 4,  $Z_m$  varies with altitude in steps from 180 m (600 ft) to 240 m (800 ft).

3.5.5.2 Since the main interest is in intruders with projected miss distances less than  $D_m$ , an ideal altitude test (in combination with an ideal range test) would give a positive result if, *inter alia*, the relative velocity vector were projected to pass through the critical area shown by the solid outline in Figure A-7. In practice, the altitude test and the range test outlined in 3.5.1.2 tend to be satisfied if the vector passes through the larger area defined by the broken outline. Those intruders passing through the shaded areas are likely to give rise to unnecessary alerts.

3.5.5.3 The altitude test is no better placed to predict the time to closest approach than is the range test. This means that, if no other conditions are applied, the range test determines the time of the alert. However, an additional feature of the altitude test of the ACAS implementation described in Section 4 attempts to guard against the eventuality that one of the aircraft levels off above or below the other, thus avoiding a close encounter. Two types of encounter are recognized: the first in which the current altitude separation is less than  $Z_t$  (see 4.3.4.2); and a second, in which the current altitude separation is greater than  $Z_t$  and the aircraft are converging in altitude. For the first type, the altitude test requires only that the critical area is projected to be penetrated. For the second an additional condition is that the time to reach co-altitude is to be less than or equal to a time threshold that is sometimes less than  $T$ , the nominal warning time. The effect is that warning time is controlled by the range test for intruders that are projected to cross in altitude before closest approach while later warnings are given for altitude crossings beyond closest approach.

### 3.5.6 ESTABLISHED THREATS

3.5.6.1 An established threat is an intruder that has been declared a threat and still merits a resolution advisory.

3.5.6.2 The need to give a positive result for both the range test and the altitude test on the same cycle of operation before declaring an intruder to be a threat (3.5.2.1) applies only for new threats. Subsequently, only the range test is applied and a positive result has the effect of maintaining threat status. The reason for omitting the altitude test is that a rapid pilot response, or the fact that the intruder initially only just satisfied the altitude criteria, may result in cancellation of threat status before reaching closest approach.

### 3.5.7 ALERT RATE

3.5.7.1 The principal variables controlling alert rate are relative velocity, miss distance and the ambient aircraft density. The principal parameters affecting alert rate are  $T$ ,  $D_m$  and  $Z_m$ . Alert rates can be calculated for constant velocity random traffic but the influences of see-and-avoid and ATC make such calculations for real traffic very difficult. Figure A-6 gives some guidance on some features of an encounter that might give rise to an alert although it gives no assistance concerning the result of the altitude test. For example, it can be seen that, for sensitivity level 5 (altitudes between FL 50 and FL 100) there can be no alert if the horizontal separation is greater than 5.5 km (3 NM) and the relative speed is less than about 440 m/s (850 kt).

3.5.7.2 Simulations using ground-based radar surveillance data and initial experience with ACAS equipments have indicated that the overall alert rate ranges from about 1 in 30 flight hours to 1 in 50 flight hours in typical busy airspaces.

### 3.5.8 THREAT RESOLUTION

#### 3.5.8.1 COORDINATION

If the threat aircraft is equipped with ACAS II or ACAS III, own ACAS is required to coordinate with the threat aircraft's ACAS via the Mode S data link to ensure that compatible RAs are selected. The nature of the advisory selected can also be influenced by the fact that the threat is ACAS-equipped.

#### 3.5.8.2 CLASSIFICATION OF RESOLUTION ADVISORIES

3.5.8.2.1 ACAS escape manoeuvres are confined to the vertical plane and can be characterized by a sense (up or down) and a strength. The objective of an RA with an upward sense is to ensure that own aircraft will safely pass above the threat. The

objective of an RA with a downward sense is to ensure that own aircraft will safely pass below the threat. Examples of RA strengths with the upward sense are “limit vertical speed” (to a specified target descent speed), “do not descend”, or “climb”. Examples of equivalent RA strengths with the downward sense are “limit vertical speed” (to a specified target climb speed), “do not climb”, or “descend”. RAs are of two types: “positive”, meaning a requirement to climb or descend at a particular rate; and “vertical speed limit”, meaning that a prescribed range of vertical speed must be avoided. Any advisory may be “corrective” or “preventive”. A corrective advisory requires a change in own aircraft’s current vertical rate whereas a preventive advisory does not.

3.5.8.2.2 It is expected that the RA generated be consistent with flight path limitations in some regimes of flight, due to flight envelope restrictions and aircraft configurations that reduce climb capability. It is expected that the aircraft’s manoeuvre limitation indications available to ACAS will offer a conservative assessment of the actual aircraft performance capabilities. This is particularly true of climb inhibit. In the rare and urgent case of a high altitude downward sense RA being reversed to a climb, it is expected that, very often, the aircraft performance capabilities needed to comply with the RA will be available despite the climb inhibit. When such capabilities are not available, it is expected that the pilot will always be able to comply with the reversal at least partially by promptly levelling-off.

### 3.5.8.3 ALTITUDE SEPARATION GOAL

3.5.8.3.1 To be certain of avoiding a collision, ACAS must provide a true altitude separation at closest approach which is commensurate with aircraft dimensions and worst-case orientation of the aircraft. Since only measured altitude data are available, due allowance must be made for altimetry errors in both aircraft. Furthermore, the avoiding action must be commenced before closest approach so it is possible that this action will be based on predicted altitude separation at closest approach, which introduces a further source of error. These factors lead to a requirement that the RA provided to the pilot should be such that the desired altitude separation at closest approach can be achieved in the time available. This altitude separation goal,  $A_t$ , must vary as a function of altitude in order to adequately compensate for altimetry errors. In the ACAS implementation described in Section 4,  $A_t$  varies from 90 m (300 ft) to 210 m (700 ft).

3.5.8.3.2 The time to closest approach cannot be estimated accurately because the miss distance is not known, the threat could manoeuvre and the range observations are imperfect. However, limits that have been found useful and acceptable are the times to closest approach assuming the miss distance to take the largest value of concern ( $D_m$ ) and the value zero, and that all other sources of error have been neglected. This interval is critical for encounters in which the range rate takes on very small values. By maintaining the altitude separation over the entire interval, the selection of the RA is made immune to potentially large errors in estimating the time of minimum range. Such errors can result from small absolute errors in estimating range rate. For preventive RAs, the assumption of an immediate change of rate to the limit recommended by the RA will cause the calculation to deliver a bound (upper for downward RAs, lower for upward RAs) on the altitude of own aircraft at closest approach.

### 3.5.8.4 MINIMUM DISRUPTION

3.5.8.4.1 In principle, the larger altitude separations goals could be achieved by a more vigorous escape manoeuvre but constraints are passenger comfort, aircraft capability and deviation from ATC clearance. The ACAS parameters described in Section 4 below are based on an anticipation that the typical altitude rate needed to avoid a collision is 1 500 ft/min.

3.5.8.4.2 The initial choice of the sense and strength of the RA is intended, subject to the exceptions described below, to require the smallest possible change in the vertical trajectory of the ACAS aircraft. And the advisory is expected to be appropriately weakened, if possible, at later stages of the encounter, and removed altogether when the desired separation has been achieved at closest approach. A prime consideration is the minimization of any departure from an ATC clearance.

### 3.5.8.5 PILOT RESPONSE

Since the pilot exercises such a major influence on the effectiveness of the system, it is necessary for any ACAS design to make certain assumptions concerning the response of the pilot. The ACAS implementation described in Section 4 uses a response delay of 5 seconds for a new advisory and a vertical acceleration of  $g/4$  to establish the escape velocity. The response time reduces to 2.5 seconds for subsequent advisory changes. ACAS may not provide adequate vertical separation if the pilot response delay exceeds the expected pilot response delay assumed by the design.

### 3.5.8.6 INTRUDERS IN LEVEL FLIGHT

3.5.8.6.1 Intruders that are flying level at the time of the alert and continue thereafter in level flight present few problems for ACAS. If own aircraft is also in level flight, the altitude prediction problem does not exist. All the ACAS aircraft has to do is to move in the direction which increases the current altitude separation to the target value. Possible obstacles to this simple logic are that the ACAS aircraft may be unable to climb, or may be too close to the ground to descend safely.

3.5.8.6.2 The manoeuvre limitation problems largely disappear when the ACAS aircraft is in climb or descent since separation can then often be obtained simply by levelling-off. And the prediction problem is likely to be a minor one if ACAS is fed with high resolution data for own altitude.

### 3.5.8.7 INTRUDERS IN CLIMB/DESCENT

Intruders in climb or descent provide more difficulty than intruders in level flight. It is often a problem to determine their altitude rates. There is also evidence that a climbing or descending threat that is projected to pass close to own aircraft is more likely to level-off than to maintain its observed altitude rate thus avoiding the close encounter. Therefore the selection of RAs by ACAS should be biased by an expectation that threats might level-off, e.g. in response to ATC. A low confidence in the threat's tracked altitude rate may cause RA generation to be delayed pending a better estimate of this rate.

### 3.5.8.8 ALTITUDE CROSSING RAS

3.5.8.8.1 Intruders that are projected to cross the altitude of an ACAS aircraft make the design of a totally effective ACAS extremely difficult because such intruders might level-off. Some of the altitude crossing RAs occasionally generated have been found counter-intuitive by pilots. Indeed, such RAs require the pilot to initially manoeuvre toward the intruder, temporarily losing vertical separation. Nevertheless, encounters for which altitude crossing RAs are clearly appropriate have been observed, and it is not yet demonstrated that it is desirable or possible to avoid them entirely. The frequency of altitude crossing RAs is likely to depend on the management and behaviour of aircraft. It is known that aircraft climbing and descending at high rates more frequently give rise to RAs, including crossing RAs, than other aircraft. The potential effect of approaching a cleared flight level at high speed and then levelling-off in close horizontal and vertical proximity to another aircraft is described below. Measures to mitigate these effects are described in 3.5.8.9.

3.5.8.8.2 For the scenario illustrated in Figure A-8, suppose that the alert occurs while the intruder is climbing towards the level ACAS aircraft. Given that the climb continues, the best escape strategy would be for own aircraft to descend towards the threat, in so doing crossing through the threat's altitude. A climb away could possibly provide enough vertical clearance but, for the same escape velocity, a descent will give greater clearance. If own aircraft does descend it can be seen that a hazardous situation arises if the threat levels off at the cardinal flight level below own aircraft. Such manoeuvres are common-place in some controlled airspaces since they are used by controllers to cross aircraft safely with the required altitude separation in situations where the horizontal separation is small. An ACAS design based on the choice of sense likely to give the greatest altitude separation could induce a close encounter where one would not otherwise occur. An ACAS design must include provisions to make it as immune as possible to such an eventuality.

3.5.8.9 *Provisions for avoiding induced close encounters.* In the absence of any knowledge concerning the intent of the threat, it appears reasonable to assume that the threat will continue with its current altitude rate but chooses the RA in an attempt to mitigate the effect of a likely threat manoeuvre. Other features must provide for the contingency that a subsequent threat manoeuvre is detected. For example, the implementation described in Section 4 uses the logic described below.

3.5.8.9.1 *Biasing the choice of sense.* If a positive non-altitude crossing advisory is predicted to give at least adequate altitude separation at closest approach ( $A_c$ ), then preference is given to the sense that prevents the aircraft from crossing in altitude before closest approach if the threat does not level-off. There is evidence that, in some circumstances, altitude crossing RAs are more disruptive than non-altitude-crossing RAs.

3.5.8.9.2 *Increased rate resolution advisory.* If the sense chosen as a result of the process described in 3.5.8.9.1 results in own aircraft moving away from the threat the encounter may still not be resolved if the threat increases its altitude rate. In such a case the pilot of the ACAS aircraft can be invited to increase own altitude rate in an attempt to outrun the threat.

3.5.8.9.3 *Altitude separation test.* Sense choice biasing will not always result in an RA to move away from the threat and the altitude separation test is provided further to decrease the chance of an induced close encounter due to a threat levelling off or reducing its altitude rate. The test involves delaying the issue of the RA until the intent of the threat can be deduced with greater confidence. It is therefore not without risk of causing ACAS to be unable to resolve the encounter. The ACAS implementation described in Section 4 balances these conflicting risks with the logic described below.

3.5.8.9.3.1 For a scenario of the type shown in Figure A-8 illustrating a threat with a significant altitude rate, the alert, without this delay, would be given when the aircraft were still well separated in altitude. For example, when the warning time is 25 seconds and the altitude rate is 900 m/min (3 000 ft/min), the initial separation is 380 m (1 250 ft). If the situation is such that an altitude crossing RA would be required, i.e. biased sense choice is ineffective, ACAS delays the issue of an advisory until the current altitude separation falls below a threshold ( $A_c$ ) that is smaller than the standard IFR separation. If the threat actually levels off at any altitude before crossing that threshold, as is most likely, the alert state will either be cancelled (for level-offs outside  $Z_m$ ), or a non-altitude crossing advisory will be generated. Otherwise, apart from the possibility that the threat has just overshoot its cleared altitude, there is every indication that it is carrying on to, or through, own aircraft's level and the altitude crossing advisory can be issued with more confidence. If the situation is such that non-altitude crossing advisory would be required, a reduced time threshold ( $T_v$ ) is used for the altitude test. This vertical threshold test (VTT) is designed to hold off the RA just long enough so that a level-off manoeuvre initiated by the intruder might be detected.

3.5.8.9.3.2 The altitude separation test was intended principally to alleviate problems experienced in an IFR traffic-only environment. It may appear to be desirable to select the value for  $A_c$  such that altitude overshoots or even non-IFR separations are covered. However, the risk of ACAS to be unable to resolve the encounters is to be taken into careful consideration.

3.5.8.9.3.3 The test takes advantage of the cooperation between two equipped aircraft by causing the ACAS in the level aircraft to delay the choice of an RA until it has received a resolution message from the equipped intruder. The ACAS in the latter must almost certainly choose a reduction in its own altitude rate and the coordination process would then result in the level aircraft being able to maintain its level status. In practice the delay in starting to resolve the encounter will be small, but the risk of failure to resolve is less sensitive to delay because both aircraft are taking avoiding action. The delay is limited to 3.0 s, which is normally sufficient for the threat to have initiated coordination.

3.5.8.9.4 *Sense reversal.* In spite of the precautions taken to avoid induced close encounters described above, there are still situations which are not covered. For example, in airspace containing VFR traffic, threat levelling-off can occur with a nominal separation of 150 m (500 ft). The altitude separation test could be less effective in such circumstances. When ACAS determines that a threat manoeuvre has defeated its initial choice of RA, the advisory sense can be reversed. The requirement to achieve the target altitude separation at closest approach may be relaxed when this course of action is taken.

### 3.5.8.10 OTHER CAUSES OF INDUCED CLOSE ENCOUNTERS

3.5.8.10.1 *Altimetry errors.* The altitude separation parameter representing the separation goal ( $A_i$ ) must include an allowance for altimetry error that is sufficient to give a high probability of not causing an ACAS-equipped aircraft to provoke a close encounter where none really existed. For gross altimetry errors, however, there remains a low probability that a close encounter will be induced when the original separation is adequate. Similarly, there is a low probability that ACAS will be unable to resolve a close encounter due to altimetry error.

3.5.8.10.1.1 The use of Gilham encoded data for either aircraft is a particular cause of altitude report errors, and induced close encounters have resulted. In the case of own aircraft, such errors can be prevented by using an altitude source that has not been Gilham encoded.

### 3.5.8.10.2 Mode C errors

3.5.8.10.2.1 Errors in encoding the threat's altitude to provide Mode C data can, when sufficiently large, induce close encounters in much the same way as gross altimetry error. The incidence of such encounters will be very low in airspaces where ATC takes steps to advise the pilot that an aircraft's reported altitude is incorrect.

3.5.8.10.2.2 A more severe form of Mode C error occurs when the error is confined to the C-bits. These are unchecked by ATC, which is normally content to find that an aircraft is within the specified tolerance value of its reported altitude. A stuck or missing C-bit can produce an error of only 30 m (100 ft). However, such a fault can have a more serious effect on the intruder's altitude rate as perceived by ACAS and in this way can cause an induced close encounter or result in failure to resolve a close encounter.

3.5.8.10.3 *Contrary pilot response.* Manoeuvres opposite to the sense of an RA may result in a reduction in vertical separation with the threat aircraft and therefore must be avoided. This is particularly true in the case of an ACAS-ACAS coordinated encounter.

### 3.5.8.11 MULTI-AIRCRAFT ENCOUNTERS

3.5.8.11.1 ACAS takes account of the possibility of three or more aircraft being in close proximity and it is required to produce an overall RA that is consistent with each of the advisories that it would give against each threat treated on an individual basis. In such circumstances it cannot always be expected that the ACAS aircraft will achieve an altitude separation of  $A_i$  with respect to all threats.

3.5.8.11.2 Simulations based on recorded ground-based radar surveillance data and initial experience with ACAS equipment have indicated that multi-aircraft conflicts are rare. Also, there is no evidence of a "domino" effect whereby the ACAS aircraft's manoeuvre to avoid a threat brings it into an encounter with a third aircraft which is equipped and so on. Such an event might be expected to take place in a holding pattern, but the available evidence does not confirm this.

## 3.5.9 VERTICAL RATE ESTIMATION

3.5.9.1 The vertical tracking algorithm must be capable of using altitude information quantized in either 25 or 100 ft increments to produce estimates of aircraft vertical rates. This tracker must avoid overestimating vertical rate when a jump in reported altitude occurs because an aircraft with a small vertical rate moves from one quantized altitude level to another. But response limitation cannot be achieved by merely increasing tracker smoothing, since the tracker would then be slow to respond to actual rate changes. For altitude reports quantized to 100 ft, the altitude tracker (in Section 4) uses special track update procedures that suppress the response to an isolated altitude transition (altitude report that differs from the preceding altitude report) without sacrificing response to acceleration. The tracker also includes several features that contribute to reliability.

3.5.9.2 Some key features of the vertical tracking algorithm are as follows:

- a) Before any altitude report is accepted for use by the update routines, tests are made to determine if the report appears reasonable, given the sequence of reports previously received. If the report appears unreasonable, it is discarded, although it may subsequently be used in checking the credibility of later reports.
- b) The algorithm recursively averages the time between altitude transitions rather than altitude reports.
- c) The tracker strictly limits the response to isolated altitude transitions (i.e. transitions that are not part of any trend in altitude). An isolated altitude transition results in initialization of the rate estimate to a specified modest rate in the direction of the transition. The rate estimate will be decayed toward zero on each successive scan without a transition.
- d) When a transition is observed that is consistent in direction with the preceding transition, a trend is declared. The altitude rate is initialized to a value consistent with the time between the two transitions.
- e) Rate oscillations due to quantization effects are suppressed when a trend or level track has been declared. During a trend period, altitude reports that indicate no altitude transition are tested to determine if the lack of a transition is consistent with the previously estimated rate. If not consistent, the rate is reset to a lower value. If consistent, the rate remains unchanged.
- f) When a trend has been declared and a transition is observed, then a test is made to see if the transition is consistent in both direction and timing with the previously estimated rate. If not consistent, the rate is reset. If consistent, the rate is updated by smoothing. The transition may be due to jitter and in reality the trend may be continuing.
- g) During each scan the tracker provides a track confidence index that indicates the degree of confidence that can be placed in the altitude rate estimate. “High” confidence is declared when recent altitude reports are consistent with both altitude and altitude rate estimates of the tracker. “Low” confidence is declared when altitude reports are not consistent, implying a possible vertical acceleration or when altitude reports are missing for two or more successive cycles. “Low” confidence might justify a delay in the generation of an RA.
- h) The tracker provides upper and lower bounds within which the true altitude rate is expected to lie. The altitude rate bounds are used to determine if RA generation is to be delayed and in assessing the need for a sense reversal when the altitude rate confidence is “low”.

### 3.5.10 AIR-AIR COORDINATION

3.5.10.1 *Coordination interrogations.* When ACAS declares a similarly equipped intruder to be a threat, interrogations are transmitted to the latter for RA coordination via the Mode S data link. These interrogations, which contain resolution messages, are made once per processing cycle as long as the intruder remains a threat. The equipped threat always acknowledges receipt of a resolution message by transmitting a coordination reply.

#### 3.5.10.2 COORDINATION INTERROGATION PROCESSING

3.5.10.2.1 ACAS processes a resolution message received from another ACAS-equipped intruder by storing the RAC for that intruder and by updating the RAC record.

3.5.10.2.2 RAC is a general term that is used to mean a vertical RAC (VRC) and/or a horizontal RAC (HRC) as appropriate. Specifically, the information provided in the Mode S interrogation is the VRC for ACAS II and the VRC and/or HRC for ACAS III.

3.5.10.2.3 The RAC record is a composite of all currently active RACs (VRCs and/or HRCs) that have been received by ACAS. The four bits in the RAC record correspond to the two VRC values (“do not pass below” and “do not pass above”)

followed by the two HRC values (“do not turn left” and “do not turn right”). If a bit in the RAC record is set, it means that the corresponding RAC has been received from one or more ACAS. Each time an RAC is received from another ACAS, the corresponding bit(s) in the RAC record is (are) set. Each time an RAC cancellation is received from another ACAS, the corresponding bit(s) is (are) cleared so long as no other ACAS is also currently causing the bit(s) to be set.

### 3.5.10.3 COORDINATION SEQUENCE

The sequence of coordination messages and associated processing is illustrated in Figure A-9. Failure to complete the coordination may result in the choice by the threat of an incompatible RA sense.

### 3.5.10.4 COORDINATION PROTOCOL

3.5.10.4.1 After declaring an equipped intruder to be a threat, ACAS first checks to see if it has received a resolution message from that threat. If so, ACAS selects an RA that is compatible with the threat’s vertical sense. If not, ACAS selects an RA based on the geometry of the encounter (3.5.2). In either case, ACAS begins to transmit vertical sense information to the threat once per scan in the form of an RA complement in a resolution message. The RA complement is “don’t pass above” when ACAS has elected to pass above the threat and “don’t pass below” when ACAS has elected to pass below the threat.

3.5.10.4.2 Upon detecting ACAS as a threat, the threat goes through a comparable process. If for any reason the two aircraft select the same (incompatible) separation sense, the aircraft with the higher 24-bit aircraft address reverses its sense. This could happen if the two aircraft detect each other as threats simultaneously or if there were a temporary link failure preventing successful communication.

### 3.5.10.5 COORDINATION DATA PROTECTION

ACAS stores the current RA and the active RAC(s) received from other ACAS-equipped aircraft that perceive own aircraft to be a threat. In order to ensure that the stored information is not modified in response to one or more ACAS while it is being used for RA selection by own ACAS, the data must be protected so that it is available to, or capable of being modified in response to, only one ACAS at a time. For example, this may be accomplished by entering the coordination lock state whenever the data store is accessed by own ACAS or offered new data from a threat ACAS. If a resolution message is received while the coordination lock state is active, the data is held until the current coordination lock state is ended. The potential for simultaneous data access by different processes within ACAS exists because incoming threat resolution messages are received asynchronously to the ACAS processing, effectively interrupting this processing.

## 3.5.11 GROUND COMMUNICATION

3.5.11.1 *Report of ACAS resolution advisories to the ground.* Whenever an RA exists, ACAS indicates to the aircraft’s Mode S transponder that it has an RA report available for a Mode S ground station. This causes the transponder to set a flag indicating that a message is waiting to be transmitted to the ground. Upon receipt of this flag a Mode S sensor may request transmission of the RA report. When this request is received, own Mode S transponder provides the message in a Comm-B reply format. In addition, ACAS generates periodic broadcasts at 8-second intervals for the time during which an RA is indicated to the pilot. The broadcast reports the last values taken by the parameters of the RA during the previous 8-second period even if the advisory has been terminated. This allows ACAS RA activity to be monitored in areas where Mode S ground station surveillance coverage does not exist by using special RA broadcast signal receivers on the ground. RA broadcasts are normally destined for ground equipment but are defined as uplink transmissions.

3.5.11.2 *Ground station control of threat detection parameters.* Threat detection parameters can be controlled by one or more Mode S ground stations by transmitting interrogations containing sensitivity level control (SLC) command messages



addressed to the ACAS aircraft. Upon receipt of an SLC command message from a given Mode S ground station, ACAS stores the SLC command value indexed by ground station number. ACAS uses the lowest of the values received if more than one ground station has sent such a message. ACAS times out each site's SLC command separately and cancels it if it is not refreshed by another message from that site within 4 minutes. ACAS can also immediately cancel an SLC command from a ground station if a specified cancellation code is received from that station. SLC commands cannot be used within linked Comm-A interrogations.

### 3.5.12 SENSITIVITY LEVEL CONTROL

Control of the ACAS threat detection parameters can be effected by means of SLC commands provided as follows:

- a) an internally generated value based on altitude band;
- b) from a Mode S ground station (see 3.5.11.2); and
- c) from a pilot-operated switch.

The sensitivity level used by ACAS is set by the smallest non-zero SLC command provided by these three sources. When a Mode S ground station or the pilot has no particular interest in the sensitivity level setting, the value zero is delivered to ACAS from that source and it is not considered in the selection process. The sensitivity level will normally be set by the internally generated value based on altitude band. Hysteresis is used around the altitude thresholds to prevent fluctuations in the SLC command value when the ACAS aircraft remains in the region of an altitude threshold.

## 3.6 Compatibility with on-board Mode S transponders

3.6.1 Compatible operation of ACAS and the Mode S transponder is achieved by coordinating their activities via the avionics suppression bus. The Mode S transponder is suppressed during and shortly after an ACAS transmission. Typical suppression periods are a) 70 microseconds from the top antenna and b) 90 microseconds from the bottom antenna. These suppression periods prevent multipath caused by the ACAS interrogation from eliciting an SSR reply from the Mode S transponder.

3.6.2 Unwanted power restriction on a Mode S transponder associated with ACAS is more stringent than in Chapter 3, 3.1.2.10.2.1 in order to ensure that the Mode S transponder does not prevent ACAS from meeting its requirements. Assuming a transponder undesired radiation power level of  $-70$  dBm (Chapter 4, 4.3.11.1) and a transponder to ACAS antenna isolation of  $-20$  dBm, the resultant interference level at the ACAS RF port will then be below  $-90$  dBm.

3.6.3 An additional compatibility requirement is to keep the leakage power of the ACAS transmitter at a low level (see 3.2.1).

## 3.7 Indications to the flight crew

### 3.7.1 DISPLAYS

3.7.1.1 ACAS implementations will typically display resolution advisory information on one or two displays. The TA display presents the crew with a plan view of nearby traffic. The RA display presents the crew with manoeuvres to be executed or avoided in the vertical plane. The TA display and the RA display may utilize separate indicators or instruments to convey information to the pilot, or the two functions may be combined on a single display. The displayed RA information can either be integrated with existing displays available on the flight deck or presented on a dedicated display.

### 3.7.1.2 TRAFFIC ADVISORIES

3.7.1.2.1 The TA display presents the flight crew with a plan view of nearby traffic. The information thus conveyed is intended to assist the flight crew in sighting nearby traffic. Simulation has demonstrated that tabular alphanumeric displays of traffic are difficult for the flight crew to read and assimilate, and the use of this type of display as the primary means of displaying traffic information is not recommended. The TA display provides the capability to display the following information for intruders:

- a) position (range and bearing);
- b) altitude (relative or absolute if the intruder is reporting altitude); and
- c) altitude rate indication for an altitude reporting intruder (climbing or descending).

3.7.1.2.2 The TA display may use shapes and colours to indicate the threat level of each displayed intruder, i.e. RAs, TAs, and proximate traffic. The essential differences between the tests for TA generation and the tests for threat detection are the uses of larger values for warning time.

3.7.1.2.3 The continuous display of proximate traffic is not a required component of ACAS. However, pilots need guidance concerning proximate traffic as well as potential threats to ensure that they identify the correct aircraft as the potential threat. The word “display” is not intended to imply that a visual display is the only acceptable means of indicating the position of intruders.

3.7.1.2.4 Ideally, an RA would always be preceded by a TA, but this is not always possible; e.g. the RA criteria might be already satisfied when a track is first established, or a sudden and sharp manoeuvre by the intruder could cause the TA lead time to be less than a cycle.

### 3.7.1.3 RESOLUTION ADVISORIES

The RA display presents the flight crew with an indication of vertical speed to be attained or avoided. The RA display may be incorporated into the instantaneous vertical speed indicator (IVSI) or into the primary flight display (PFD). The RA display may provide a means to differentiate between preventative and corrective RAs.

## 3.7.2 AURAL AND VOICE ALERTS

Aural alerts are used to alert the flight crew that a TA or RA has been issued. When the vocabulary used to announce RAs is selected, care must be taken to select phrases that minimize the probability of a misunderstood command. An aural annunciation is also provided to the flight crew to indicate that the ACAS aircraft is clear of conflict with all threatening aircraft.

## 3.8 Crew control functions

As a minimum, it is expected that a means be provided manually through flight crew action for either selecting an “AUTOMATIC” mode in which sensitivity levels are based on other inputs, selecting a mode in which only TAs are able to be issued, or selecting specific sensitivity levels including at least sensitivity level 1. When sensitivity level 1 is selected, the ACAS equipment is essentially in a “stand-by” condition. The term STAND-BY may be used to designate this selection. The current ACAS sensitivity level may be different from that selected by the flight crew. Provisions are to be made for indicating to the flight crew when ACAS is in STAND-BY or when only TAs will be issued. The control for ACAS may be integrated with the controls for the Mode S transponder, or the two systems may have separate controls. If the ACAS and Mode S controls are integrated, a means must be provided to allow the flight crew to select a transponder-only mode of operation.

### 3.9 Performance monitoring

ACAS equipment is expected to include an automatic performance monitoring function for determining on a continuing basis the technical status of all critical ACAS functions without interfering with or otherwise interrupting the normal operation of the equipment. Provisions are to be made for indicating to the flight crew the existence of abnormal conditions as determined by this monitoring function.

## 4. TYPICAL ALGORITHMS AND PARAMETERS FOR THREAT DETECTION AND GENERATION OF ADVISORIES

*Note 1.— The characteristics given below describe a reference design for the ACAS II collision avoidance logic. This description, however, does not preclude the use of alternative designs of equal or better performance.*

*Note 2.— Lower case mathematical symbols are used to represent variables throughout this section. Upper case symbols are used for parameters. The dot notation used for some parameters does not indicate that they are derived quantities but rather that they have the dimensions suggested by the notation, e.g. distance/time for a speed parameter.*

### 4.1 Tracking performance characteristics

#### 4.1.1 RANGE TRACKING

Range, range rate, and range acceleration ( $r, \dot{r}, \ddot{r}$ ) are estimated by means of an adaptive  $\alpha$ - $\beta$ - $\gamma$  tracker using for its coefficients  $\alpha$ ,  $\beta$ , and  $\gamma$  values that are decreasing with each successive range measurement until they reach their minimum values equal to 0.40, 0.10 and 0.01, respectively. The range acceleration estimate is used to estimate the expected miss distance in range at closest approach,  $m$ , using the following formula:

$$m^2 = r^2 - \frac{r^2}{1 + r\ddot{r} / \dot{r}^2}$$

This estimate is not calculated when further calculations indicate that it may not be reliable either because of the magnitude of the estimation errors or because of a possible manoeuvre by one of the aircraft in the horizontal plane. The latter calculations rely on the age of the track, the observed accuracy of the successive range predictions, the observed consistency of the range acceleration estimates, the observed consistency of a second range track based on a linearized trajectory agreeing with the previously estimated miss distance, and the observed consistency of a rough bearing track.

#### 4.1.2 ALTITUDE TRACKING

4.1.2.1 *Sources of altitude data.* Intruder aircraft's altitude is obtained from intruder Mode C or Mode S reports. Own aircraft's altitude is obtained from the source that provides the basis for own Mode C or Mode S reports and is required to be at the finest quantization available.

4.1.2.1.1 *Altitude report credibility.* Before any altitude report is accepted, a test is made to determine whether the report is credible. A credibility window is calculated on the basis of the previous estimated altitude and altitude rate. The altitude report is discarded and the altitude track updated as though the report was missing (4.1.2.3.7) if the report is outside the credibility window.

4.1.2.2 *Own altitude rate.* Own ACAS aircraft's altitude rate is obtained from a source having errors that are as small as possible and in any event no greater than those of the rate output of the tracker described in 4.1.2.3.6.

#### 4.1.2.3 *INTRUDER ALTITUDE TRACKING*

##### 4.1.2.3.1 *Altitude tracking terms' description*

*Established rate track.* An altitude track for which the pattern of the last few altitude reports received from the intruder allows the inference that that intruder is climbing or descending with a constant, non-zero altitude rate.

*Level track.* An altitude track for which the pattern of the last few altitude reports received from the intruder allows the inference that that intruder is level.

*New track.* An altitude track newly initialized.

*Oscillating track.* An altitude track for which the pattern of the last few altitude reports received from the intruder oscillates between two or more values in a way that allows the inference that that intruder is level.

*Transition.* An altitude report for a track that is different from the last credible altitude report for that track.

*Trend.* A trend exists for the altitude rate if the two most recent altitude level transitions were in the same direction.

*Unconfirmed rate track.* An altitude track for which the pattern of the last few altitude reports received from the intruder does not allow the track to be classified in any other way.

4.1.2.3.1.1 On any cycle of tracking, each track is attributed one and only one track classification.

4.1.2.3.1.2 Any track classification is maintained until conditions for another track classification are satisfied.

4.1.2.3.2 The ACAS II tracks the altitudes of intruders. Tracking is based on automatic pressure-altitude reports from their transponders, using altitude reports quantized as received. For every intruder on every cycle the tracker provides altitude and altitude rate estimates.

*Note.— The function that associates Mode C altitude data with tracks is specified in Chapter 4, 4.3.2.1. The altitude tracker specified below assumes that this function has been performed prior to application of the tracker.*

4.1.2.3.2.1 The reference altitude tracking design assumes that, for each track, altitude reports are received at the nominal rate of one altitude report per second. However, it allows for missing reports, in other words, cases in which no altitude report has been received for a given track prior to a tracking cycle.

4.1.2.3.2.2 Intruder altitude tracks of one of two types are created and maintained. So-called 100-ft tracks are obtained when altitude reports are supplied in units of 100 ft. Such tracks are updated by a dedicated tracker referred to as the 100-ft altitude tracker. So-called 25-ft tracks are obtained when altitude reports are supplied in units of 25 ft. Such tracks are updated by a dedicated tracker referred to as the 25-ft altitude tracker.

4.1.2.3.2.3 Special logic automatically switches intruder altitude tracks between the 100-ft altitude tracker and the 25-ft altitude tracker following a confirmed change in the units in which altitude reports are supplied. Such a change is considered confirmed when three successive valid altitude reports expressed in the same units have been received.

4.1.2.3.2.4 When an altitude reporting unit change has been observed but not yet been confirmed, the existing track is coasted and the altitude report is temporarily stored. Once the unit change is confirmed, the track is re-initialized using the last altitude rate estimate computed before the change as well as all temporarily stored altitude reports.

4.1.2.3.2.5 The 25-ft tracker is an adaptive alpha-beta tracker. It is briefly described in 4.1.2.3.5.

4.1.2.3.2.6 The design of the 100-ft altitude tracker is motivated by the need for a stable altitude rate estimate when the true altitude rate of the intruder is less than 100 ft/s, in other words, less than one quantization interval per tracking cycle. This tracker estimates the altitude rate indirectly by estimating the time taken to cross one quantization level. Further details on this design are provided in 4.1.2.3.6.

4.1.2.3.3 *Altitude rate confidence.* For every intruder on every cycle, the tracker provides an indication of either “high” or “low” confidence in the altitude rate estimate (4.1.2.3.6.9 and 4.1.2.3.6.10).

4.1.2.3.4 *Altitude rate reasonableness.* The tracker provides a “best estimate” altitude rate and upper and lower bounds for this altitude rate consistent with the received sequence of reports.

#### 4.1.2.3.5 25-ft quantization reports

4.1.2.3.5.1 For altitude reports quantized to 25-ft increments, an adaptive  $\alpha$ - $\beta$  tracker is used. This tracker is adaptive in the sense that it selects among three sets of  $\alpha$  and  $\beta$  values depending on the magnitude of the prediction error, i.e. the difference between the predicted altitude and the reported altitude, as well as on the magnitude of the rate estimate. These  $\alpha$  and  $\beta$  values are:

- $\alpha = 0.4$  and  $\beta = 0.100$  when the current altitude rate estimate is less than 7.0 ft/s; otherwise,
- $\alpha = 0.5$  and  $\beta = 0.167$  when the prediction error is less than 22.5 ft; and otherwise,
- $\alpha = 0.6$  and  $\beta = 0.257$ .

4.1.2.3.5.2 The tracker maintains two distinctive sets of altitude and altitude rate estimates. The first one is derived directly from the standard  $\alpha$ - $\beta$  smoothing equations. This set is purely internal to the tracker. The second set contains the estimates passed to the collision avoidance logic. It differs from the first set as follows. The altitude estimate passed to the logic is constrained to be within one-half quantization interval of the reported altitude ( $\pm 12.5$  ft). The altitude rate estimate passed to the logic is set equal to zero when the internal estimate decreases below 2.5 ft/s in absolute value and is kept equal to zero until the internal estimate increases beyond 5.0 ft/s in absolute value.

4.1.2.3.5.3 The tracker uses only two of the previously defined track classifications: level track and established rate track (4.1.2.3.1). It declares a track to be a level track when at least seven tracking cycles have elapsed since the last altitude transition (4.1.2.3.1). The internal rate estimate is then reset to zero. It declares the track to be an established rate track when, following two sufficiently closely spaced altitude transitions, the internal rate estimate (and thus also the rate estimate passed to the logic) increases beyond 5.0 ft/s.

4.1.2.3.5.4 Confidence in the estimates is declared “high” when the track has existed for at least four tracking cycles and the prediction error has been no greater than 22.5 ft on at least two successive tracking cycles. It is set to “low” when the prediction error is larger than 22.5 ft. It is also set to “low” when altitude reports have been missing on two successive cycles.

4.1.2.3.6 *100-ft quantization reports.* For altitude reports quantized to 100-ft increments, the performance of the altitude tracker is, in all respects, equal to or better than that of a reference tracker setting the altitude rate estimate to have an appropriate sign and the magnitude as described in this paragraph.

4.1.2.3.6.1 *Tracker variables.* The reference tracker uses the following variables:

$\dot{z}$  altitude rate estimate, m/s (ft/s);

$\dot{Z}_{gu}$  see 4.1.2.3.6.5.1;

$\Delta z$	altitude difference between the current report and the most recent credible report;
$T_n$	1 s;
$Q$	30.5 m (100 ft);
$t_r$	time since the most recent credible report, s;
$t_p$	time between the two most recent altitude level transitions or, for multiple transitions within one cycle, the average time between these transitions, s;
$t_b$	estimated level occupancy time after the most recent transition, s;
$t_{bm}$	calculated lower bound on level occupancy time, s;
$\beta$	computed smoothing coefficient for $t_b$ ;
$\beta_f$	limit for $\beta$ based on $t_b$ ;
$b_t$	number of altitude levels crossed between the two most recent altitude level transitions;
$b_z$	number of altitude levels crossed at the most recent rate;
$\varepsilon$	smoothed error estimate of $t_b$ , s;
$d_t$	sign of the most recent altitude transition (= +1 for an increase in altitude; = -1 for a decrease); and
$x^*$	value of any variable $x$ before being updated following an altitude level transition.

4.1.2.3.6.2 *Report credibility.* The altitude report is regarded as being credible if either of the following conditions is satisfied:

- a)  $\Delta z = 0$
- b)  $|\Delta z - \dot{z}t_r| - Q t_r / T_n - \dot{Z}_{gu} t_r \leq 0$

#### 4.1.2.3.6.3 *Track classification scheme*

*Established rate track.* An altitude track is classified as established rate if two or more successive transitions are observed in the same direction and the time interval between the two transitions is sufficiently short that the track classification would not be changed to level track during that interval (see the definition of level track), or if an observed transition is opposite in direction to an existing trend and the time since the previous transition is “unexpectedly small” (4.1.2.3.6.8.1).

*Level track.* An altitude track is classified as level if reports are received at the same level for longer than  $T_1$  after the time at which the next transition was expected, if one was expected, or for more than  $T_2$  whether or not a transition was expected (4.1.2.3.6.3.1).

*New track.* An altitude track is classified as new during the period between the time of the first altitude report and the first transition or until  $T_2$  has elapsed (4.1.2.3.6.3.1).

*Oscillating track.* An altitude track is classified as oscillating if a transition occurs in the opposite direction to that of the immediately preceding transition, only one level has been crossed, the time interval between the two transitions is

sufficiently short that the track classification would not be changed to level track during that interval (see the definition of level track) and, if the track was classified as established rate, the time since that transition is not “unexpectedly small” (4.1.2.3.6.8.1).

*Unconfirmed rate track.* An altitude track is classified as unconfirmed rate if a transition occurs for a new or for a level track or if a transition in the opposite direction to the previous transition occurs and more than one level has been crossed for an established, oscillating or unconfirmed rate track.

4.1.2.3.6.3.1 The following values are used:

$$T_1 = 4.0 \text{ s}$$

$$T_2 = 20 \text{ s}$$

4.1.2.3.6.3.2 If a track is already classified as unconfirmed rate and a transition occurs in the opposite direction to the previous one and more than one level has been crossed, the altitude rate is determined as if the track had just become classified as unconfirmed rate (4.1.2.3.6.5).

4.1.2.3.6.3.3 The tracks are classified (4.1.2.3.6.3), and the transitions between track classifications are shown in Figure A-10. Tracks are classified in order to determine how new measurements should be used to update the altitude rate estimate.

4.1.2.3.6.4 The magnitude of the rate is set to zero if the track is new, level or oscillating.

4.1.2.3.6.4.1 The quantities  $\varepsilon$  and  $b_z$  are set to zero and  $t_b$  to 100 s.

4.1.2.3.6.4.2 When a track is classified as level, all earlier transitions and any current trend are disregarded.

4.1.2.3.6.5 The magnitude of the rate is set to  $\dot{Z}_{gu}$  when a track first becomes unconfirmed rate and then decayed each cycle from the value determined the previous cycle until another transition is observed.

4.1.2.3.6.5.1 The value of  $\dot{Z}_{gu}$  is 2.4 m/s (480 ft/min) and the decay constant is 0.9.

4.1.2.3.6.5.2 The quantities  $\varepsilon$  and  $b_z$  are set to zero and  $t_b$  to  $Q/|\dot{z}|$

4.1.2.3.6.6 For established rate tracks the magnitude of the rate is set to the quantization interval divided by the estimated level occupancy time. The level occupancy time is estimated on receipt of transitions in the direction of the trend and held constant until the next transition either occurs or becomes overdue (4.1.2.3.6.7).

4.1.2.3.6.6.1 When a track is first established, the quantities  $\varepsilon$ ,  $b_z$  and  $t_b$  are set as follows:

$$\varepsilon = 0, b_z = 1, t_b = \text{maximum}(t_p, 1.4 \text{ s})$$

4.1.2.3.6.6.2 Unless the transition is early or late (4.1.2.3.6.6.3), the quantities  $\varepsilon$ ,  $b_z$  and  $t_b$  are calculated by recursive averaging following the third and subsequent transitions as follows:

$$\varepsilon' = 0.8\varepsilon^* + (t_p - t_b^*)$$

$$\beta_j = \frac{(t_b^* - T_n)^2}{[(t_b^*)^2 + 64T_n^2]}$$

$$b_z = b_z^* + b_t \text{ and}$$

$$\beta = \text{maximum} \left( \frac{b_t}{b_z}, \beta_f \right) \text{ and}$$

$$\varepsilon = \varepsilon'$$

for  $|\varepsilon'| \leq 1.35$  (or 2.85 if the most recent transition was observed following one or more missing reports);

$$b_z = 3 \text{ and}$$

$$\beta = 0.5 \text{ and}$$

$$\varepsilon = 0.3\varepsilon' \text{ otherwise;}$$

and in both cases:  $t_b = t_b^* + \beta(t_p - t_b^*)$ .

#### 4.1.2.3.6.6.3 Early or late transitions

If  $|t_p - t_b^*| > 1.5$  s (or 3.0 s if the most recent transition was observed following one or more missing reports) or  $b_t$  lies outside the range  $(t_p/t_b^* + 1.1) \geq b_t \geq (t_p/t_b^* - 1.1)$ , then the quantities  $\varepsilon$ ,  $b_z$  and  $t_b$  are set as follows:

$$\begin{aligned} b_z &= 1 \\ \varepsilon &= 0 \\ t_{bm} &= \text{minimum} ((0.7t_p + 0.3t_b^*), 1.4 \text{ s}) \\ t_b &= \text{maximum} (t_p, t_{bm}). \end{aligned}$$

The rate is calculated as:  $\dot{z} = d_t Q/t_b$ .

4.1.2.3.6.7 *Overdue transition.* The magnitude of the rate is decayed on each cycle from the value obtained on the previous cycle if reports are received at the same level for at least  $T_3$  after the time of the next expected transition (or  $T_4$  if the most recent transition was observed following one or more missing reports). The value of  $t_b$  is not changed in these circumstances.

4.1.2.3.6.7.1 The following values are used:

$$T_3 = 1.5 \text{ s}$$

$$T_4 = 3.0 \text{ s}$$

The following formula for rate decay is used:

$$\dot{z} = d_t Q [t_b + (0.3t_b + 0.5T_n) (0.7 + (t_l - t_b)/T_n)^2]$$

where  $t_l$  = time since the most recent transition, s.

4.1.2.3.6.7.2 The quantity  $b_z$  is set to maximum  $(2, b_z^* - 1)$ .

4.1.2.3.6.8 *Transitions due to jitter.* The magnitude of the rate is set to the value obtained on the previous cycle if a transition is observed opposite in direction to that of the trend, the immediately preceding transition followed the trend, only one level has been crossed and the time since the immediately preceding transition is “unexpectedly small”. Such a transition is subsequently treated as missing except for the requirements of 4.1.2.3.4 and 4.1.2.3.6.10 e).



4.1.2.3.6.8.1 The time since the immediately preceding transition is declared “unexpectedly small” when  $t_p \leq 0.24 t_b^*$ .

4.1.2.3.6.8.2 The quantities  $\varepsilon$ ,  $b_z$  and  $t_b$  are not changed.

4.1.2.3.6.9 *Track high confidence declaration.* “High” confidence in the tracked rate is declared when the current altitude report is credible and one or more of the following conditions are met:

- a) a new track has been observed for longer than  $T_5$  (4.1.2.3.6.9.1) without an altitude transition; or
- b) an unconfirmed rate track has been observed for longer than  $T_6$  (4.1.2.3.6.9.1) without an altitude transition; or
- c) a track is classified as level; or
- d) a track is first classified as established rate; or
- e) for an established rate track when a transition has occurred the ratio of the observed transition time to the expected transition time (before being updated) falls between  $\mathfrak{R}_1$  and  $\mathfrak{R}_2$  (4.1.2.3.6.9.1); or the absolute value of the difference between these times is less than  $T_8$ ; or the time between the most recently observed and the previous transition is longer than  $T_8$  (4.1.2.3.6.9.1); or
- f) for an established rate track when a transition has occurred, the previous report was missing,  $|t_p - t_b^*| \geq T_7$ ,  $t_p/t_b^* \geq 1$  and  $-t_p - T_9 \leq (t_b - t_p) b_t \leq T_9$ ; or
- g) a track is classified as oscillating; or
- h) confidence was previously set to “high” upon processing of the last credible altitude report and conditions a) to e) of 4.1.2.3.6.10 for “low” confidence declaration are not satisfied.

4.1.2.3.6.9.1 The following values are used:

$$T_5 = 9 \text{ s}$$

$$T_6 = 9 \text{ s}$$

$$T_7 = 1.1 \text{ s}$$

$$T_8 = 8.5 \text{ s}$$

$$T_9 = 1.25 \text{ s}$$

$$\mathfrak{R}_1 = 2/3$$

$$\mathfrak{R}_2 = 3/2$$

4.1.2.3.6.10 *Track low confidence declaration.* “Low” confidence in the tracked rate is declared when one or more of the following conditions are satisfied:

- a) for a new track until condition a) in 4.1.2.3.6.9 is satisfied; or
- b) for an unconfirmed rate track until condition b) in 4.1.2.3.6.9 is satisfied; or
- c) when an observed transition time for an established rate track does not satisfy condition e) or condition f) in 4.1.2.3.6.9; or
- d) when an expected transition is more than  $T_{10}$  (4.1.2.3.6.10.1) late; or
- e) for an established rate track when the condition in 4.1.2.3.6.8 is satisfied; or
- f) confidence was previously “low” and the conditions for “high” confidence declaration are not satisfied (4.1.2.3.6.9).

4.1.2.3.6.10.1 The value  $T_{10} = 0.25$  s is used.

4.1.2.3.7 *Missing altitude reports.* When altitude reports are missing:

- a) the previous value of the altitude rate estimate is maintained; and
- b) confidence in the tracked rate is declared “low” when altitude reports are missing for two or more successive cycles.

## 4.2 Traffic advisories (TAs)

### 4.2.1 TA GENERATION

4.2.1.1 A TA is generated for an intruder reporting Mode C altitude when the application of both a range test (4.2.3) and an altitude test (4.2.4) gives a positive result for each in the same cycle of operation.

4.2.1.2 A TA is generated for an intruder equipped with a non-altitude-reporting transponder when the result of applying a range test (4.2.3) is positive.

### 4.2.2 TA WARNING TIME

For intruders reporting altitude, the range test for TAs gives a nominal warning time as follows:

$S$	2	3	4	5	6	7
TA warning time	$T+10$	$T+10$	$T+10$	$T+15$	$T+15$	$T+13$

where  $S$  = sensitivity level

4.2.2.1 The values for  $T$  for sensitivity levels 3 to 7 are those given in 4.3.3.3.1. The value for  $T$  for sensitivity level 2 is 10 s.

### 4.2.3 TA RANGE TEST

The range test for TAs has the same form as that used for threat detection (4.3.3). The values used for  $D_m$  for sensitivity levels 3 to 7 are those given in 4.3.3.1.1 incremented by  $g(T_w - T)^2/6$  where  $T_w$  is the desired TA warning time. The base value for  $D_m$  for sensitivity level 2 is 0.19 km (0.10 NM).

### 4.2.4 TA ALTITUDE TEST

The altitude test gives a positive result if one of the following sets of conditions is satisfied:

- a) current altitude separation is “small”; or
- b) the aircraft are converging in altitude and the time to co-altitude is “small”.

These terms and conditions are defined in 4.3.4.1, 4.3.4.2, 4.3.4.3 and 4.3.4.5. The time threshold for time to co-altitude is the TA warning time (4.2.2) and the values used for  $Z_t$  are as follows:

$z_o$ FL	below 300	above 300
$Z_t$ m	260	370
( $Z_t$ ft)	850	1 200)

### 4.3 Threat definition

#### 4.3.1 THREAT DETECTION CHARACTERISTICS

4.3.1.1 *Intruder characteristics.* The characteristics of an intruder that are used to define a threat are:

- a) tracked altitude:  $z_i$
- b) tracked rate of change of altitude:  $\dot{z}_i$
- c) tracked slant range:  $r$
- d) tracked rate of change of slant range:  $\dot{r}$
- e) sensitivity level of intruder's ACAS:  $S_i$

For an intruder not equipped with ACAS II or ACAS III,  $S_i$  is set to 1.

4.3.1.2 *Own aircraft characteristics.* The following characteristics of own aircraft are used in threat definition:

- a) altitude:  $z_o$
- b) rate of change of altitude:  $\dot{z}_o$
- c) sensitivity level of own ACAS (Chapter 4, 4.3.4.3):  $S_o$ .

4.3.1.3 *Altitude-band SLC command.* The reference logic selects the SLC command based altitude band as indicated in Table A-1.

4.3.2 *Criteria for threat declaration.* An intruder becomes a threat if and only if both the following apply on the same cycle:

- a) the range test gives a positive result; and
- b) either:
  - 1) the altitude test gives a positive result; or
  - 2) an altitude-crossing RAC has been received from the threat.

4.3.2.1 *Established threat.* The threat status of an established threat is maintained on successive cycles if, as a minimum, the range test gives a positive result.

## 4.3.3 RANGE TEST

4.3.3.1 *Range convergence.* Aircraft are considered converging in range if the estimated range rate is less than  $\dot{R}_t$ . In this case the range rate estimate used in the range test is the minimum of the estimated range rate and  $-\dot{R}_t$ .

4.3.3.1.1 The value 3 m/s (6 kt) is used for  $\dot{R}_t$ .

4.3.3.2 *Range divergence.* Aircraft that are not considered converging in range are considered diverging in range. Range divergence is considered “slow” if the product of the estimated range multiplied by the estimated range rate is less than  $\dot{P}_m$ .

4.3.3.2.1 The following values are used for  $\dot{P}_m$  :

<i>S</i>	3	4 to 6	7
$\dot{P}_m$ km <sup>2</sup> /s	0.0069	0.0096	0.0137
( $\dot{P}_m$ NM <sup>2</sup> /s)	0.0020	0.0028	0.0040

4.3.3.3 *Range test criteria.* The range test gives a positive result when one of the following conditions is satisfied:

- a) both
- 1) the aircraft are converging in range; and
  - 2) the following inequality is satisfied:

$$(r - D_m^2 / r) / |r'| < T;$$

where  $r' = \text{minimum}(\dot{r}, -\dot{R}_t)$ ; or

- b) the aircraft are diverging in range but the range is less than  $D_m$  and the range divergence is “slow”; or
- c) either a miss distance estimate could not be calculated on the current cycle or the calculated miss distance is less than  $H_m$ ;

and for all other conditions the result of the range test is negative.

*Note.— The formula in item a) 2) above provides a practical test for the following condition: the range and range rate estimates indicate that the encounter could be such that the linear miss distance is less than or equal to  $D_m$  and the linear time to closest approach is less than  $T$ .*

4.3.3.3.1 The values of the parameters  $T$ ,  $D_m$  and  $H_m$  are as follows:

<i>S</i>	3	4	5	6	7
<i>T</i> s	15	20	25	30	35
$D_m$ (km)	0.37	0.65	1.0	1.5	2.0
( $D_m$ (NM))	0.20	0.35	0.55	0.80	1.1)
$H_m$ (m)	382	648	1 019	1 483	2 083
( $H_m$ (ft))	1 251	2 126	3 342	4 861	6 683)

## 4.3.4 ALTITUDE TEST

## 4.3.4.1 ALTITUDE TEST TERMS' DESCRIPTION

*Altitude divergence rate* ( $\dot{a}$ ). The rate of change of  $a$ .

*Current altitude separation* ( $a$ ). The modulus of the current tracked altitude separation between own aircraft and the intruder.

*Times to closest approach* ( $\tau_u$ ,  $\tau_m$ ). The estimated time which will be taken to reach minimum range.  $\tau_u$  is the maximum value (assuming rectilinear relative motion and zero miss distance) and  $\tau_m$  is the minimum value (assuming rectilinear relative motion and the maximum miss distance of interest,  $D_m$ ).

*Time to co-altitude* ( $\tau_v$ ). The estimated time which will be taken to reach co-altitude.

*Vertical miss distance* ( $v_m$ ). An estimated lower bound for the projected altitude separation at the estimated time of closest approach.

4.3.4.2 *Current altitude separation*. Current altitude separation is declared “small” if  $a < Z_t$  where  $Z_t$  is set equal to  $Z_m$  (4.3.4.4.2) in the reference logic.

## 4.3.4.3 ALTITUDE CONVERGENCE

4.3.4.3.1  $\dot{a}$  is calculated as follows:

$$\dot{a} = \dot{z}_o - \dot{z}_i \text{ for } z_o - z_i \geq 0$$

$$\dot{a} = \dot{z}_i - \dot{z}_o \text{ for } z_o - z_i < 0$$

4.3.4.3.2 The aircraft are declared converging in altitude if  $\dot{a} < -\dot{Z}_c$ .

4.3.4.3.3 The value of  $-\dot{Z}_c$  is positive and not greater than 0.3 m/s (60 ft/min).

## 4.3.4.4 VERTICAL MISS DISTANCE

4.3.4.4.1 When the aircraft are converging in range ( $\dot{r} \leq 0$ ), time to closest approach and vertical miss distance are calculated as follows:

$$\dot{r}' = \text{minimum} (\dot{r}, -\dot{R}_t)$$

$$\tau_u = \text{minimum} (|r / \dot{r}'|, T)$$

$$\tau_u = \left| r - D_m^2 / r \right| / \dot{r}'$$

$$\text{for } r \geq D_m$$

$$= 0 \text{ for } r < D_m$$

$$v_{m1} = (z_o - z_i) + (\dot{z}_o - \dot{z}_i) \tau_u$$

$$v_{m2} = (z_o - z_i) + (\dot{z}_o - \dot{z}_i) \tau_m$$

$$v_m = 0 \text{ for } v_{m1}v_{m2} \leq 0, \text{ otherwise}$$

$$v_m = \text{minimum } (v_{m1}, v_{m2}) \text{ for } v_{m1} > 0$$

$$= \text{maximum } (v_{m1}, v_{m2}) \text{ for } v_{m1} < 0$$

4.3.4.4.2 Vertical miss distance is declared “small” if  $|v_m| < Z_m$ . The maximum values for  $Z_m$  are given by:

$z_o$ FL	below 200	200 to 420	above 420
$Z_m$ (m)	183	213	244
$Z_m$ (ft)	600	700	800

#### 4.3.4.5 TIME TO CO-ALTITUDE

4.3.4.5.1 The time to co-altitude for  $\dot{a}$  less than  $-\dot{Z}_c$  is calculated as follows:

$$\tau_v = -a/\dot{a}$$

*Note.*—  $\tau_v$  is not used if the aircraft are not converging in altitude and range.

4.3.4.5.2  $\tau_v$  is declared “small” if  $\tau_v < T_v$  for encounters in which the magnitude of own aircraft’s vertical rate is not more than 600 ft/min or own aircraft’s vertical rate has the same sign as but smaller magnitude than that of the intruder. For all other encounters  $\tau_v$  is declared “small” if  $\tau_v < T$ . The values of the parameters  $T_v$  are as follows:

$S$	3	4	5	6	7
$T_v$ s	15	18	20	22	25

4.3.4.6 *Altitude test criteria.* The altitude test of the reference logic gives a positive result when any of the three following conditions are satisfied:

- the aircraft are converging in range, the current altitude separation is “small” and the vertical miss distance is “small”; or
- the aircraft are converging in range and altitude, the time to co-altitude is “small” and either the vertical miss distance is “small”, or co-altitude is predicted to occur before closest approach ( $\tau_v < \tau_u$ ); or
- the aircraft are diverging in range and the current altitude separation is “small”;

and for all other conditions the results of the altitude test are negative.

## 4.4 Generation of RAs

4.4.1 RA types are defined in Chapter 4, 4.1.

### 4.4.2 DELAY IN RA GENERATION

*Note.*— An RA will be generated for all threats except in the circumstances described here or for coordination purposes.

The reference logic does not generate a new RA or modify an existing RA for a new threat when any of the following conditions are satisfied:

- a) an altitude-crossing RAC has not been received from the threat; and
- b) either:
  - 1) the altitude separation test (4.4.2.1) gives a negative result; or
  - 2) confidence in the tracked altitude rate of the intruder is “low” and no resolution manoeuvre would provide a predicted separation of at least  $A_t$  (4.4.2.2), whether the threat had an altitude rate equal to the upper altitude rate bound, to the lower altitude rate bound, or to any altitude rate between these bounds (4.1.3.3.4); or
  - 3) there is “low” confidence in the threat’s tracked altitude rate, the current altitude separation is greater than 46 m (150 ft), and the RA that would be selected against the threat when considered separately from other possible threats would be altitude crossing.

#### 4.4.2.1 ALTITUDE SEPARATION TEST

4.4.2.1.1 The altitude rate of own aircraft is declared “small” if  $|\dot{z}_o| \leq \dot{Z}_\ell$ .

4.4.2.1.2 The value 3.0 m/s (600 ft/min) is used for  $\dot{Z}_\ell$ .

4.4.2.1.3 The delay in threat declaration is declared “acceptable” if it is less than 3.0 s.

4.4.2.1.4 The maximum altitude separation threshold,  $A_c$ , is given a value of 260 m (850 ft), when the vertical rates of own and of the threat are in the opposite directions and neither of them is “small”, and a value of 183 m (600 ft) otherwise.

4.4.2.1.5 Altitude separation is declared “minimum” if it is equal to 100 ft.

4.4.2.1.6 An encounter is declared “slow closing” if the range rate is greater than  $D_m/T$ .

4.4.2.1.7 *Test conditions.* The altitude separation test gives a negative result if the threat is a new threat and the RA that would be selected against the new threat when considered separately from other possible simultaneous threats would be either:

- a) altitude crossing and either:
  - 1) the current altitude separation exceeds  $A_c$ ; or
  - 2) the threat is equipped, a valid RAC has not been received from it, the altitude rate of own aircraft is “small”, the altitude rate of the threat is not “small”, and the delay in issuing an RA or modifying the existing RA is “acceptable”; or
- b) unable to generate at least “minimum” separation over the critical interval if the encounter is not “slow closing”; or
- c) unable to generate at least “minimum” separation at closest approach ( $\tau_u$ ) if the encounter is “slow closing” and either range is less than  $D_m$  or time to a range of  $D_m$ ,  $\tau_m$ , is less than 5 s.

Otherwise, the result of the altitude separation test is positive.

4.4.2.2 The following values are used for  $A_t$ :

$z_o$	$A_t$ m	( $A_t$ ft)
less than FL 100	61	(200)
FL 100 to FL 200	73	(240)
FL 201 to FL 420	122	(400)
greater than FL 420	146	(480)

4.4.2.2.1 Hysteresis of  $\pm 500$  ft is applied to the boundaries between adjacent altitude layers.

4.4.3 *Altitude separation goal.* The initial strength of the RA is selected to meet the goal of an altitude separation of at least  $A_t$  at closest approach except in the circumstances described in 4.4.3.2.

4.4.3.1 The following values are used for the parameter  $A_t$ :

$z_o$	$A_t$ m	( $A_t$ ft)
less than FL 50	91	(300)
FL 50 to FL 100	107	(350)
FL 100 to FL 200	122	(400)
FL 201 to FL 420	183	(600)
greater than FL 420	213	(700)

4.4.3.1.1 Hysteresis of  $\pm 500$  ft is applied to the boundaries between adjacent altitude layers.

4.4.3.2 *Inadequate vertical separation.* If the restrictions on RAs (Chapter 4, 4.3.5 and 4.4.4 below) preclude the generation of an RA predicted to provide an altitude separation at closest approach of at least  $A_t$ , the RA is that predicted to provide the largest altitude separation at closest approach consistent with the other provisions in this chapter.

4.4.3.3 *Critical interval.* Predictions for closest approach are for the period of time during which a collision could occur.

4.4.3.3.1 The critical interval is that time between  $\tau_{m\ell}$  and  $\tau_{u\ell}$  where:

$$\dot{r}' = \text{minimum} (\dot{r}, -\dot{R}_t)$$

$$\tau_{u\ell} = \text{minimum} (\tau_{u\ell}^*, |r / \dot{r}'|, T_e)$$

$$\tau_{m\ell} = \text{minimum} (\tau_{m\ell}^*, |(r - D_m^2/r) / \dot{r}'|)$$

for  $r \geq D_m$

$T_{m\ell} = 0$  for  $r < D_m$

where  $\tau_{u\ell}^*$  and  $\tau_{m\ell}^*$  are both equal to  $T_e$  for a threat that has newly passed the range test (4.3.3) and are the values of  $\tau_{u\ell}$  and  $\tau_{m\ell}$ , respectively, on the previous cycle otherwise.

4.4.3.3.1.1 The following parameter values are used:

$S$	3	4	5	6	7
$T_e, s$	25	30	30	35	40



4.4.3.4 *The threat trajectory.* The RA is designed to provide altitude separations sufficient to avoid collisions with threats that:

- a) continue with their current altitude rates; or
- b) are climbing or descending when they first become threats and reduce their altitude rates or manoeuvre to level flight.

4.4.3.4.1 Predicted altitude separation is based on the assumption that the threat will maintain its current altitude rate except as described in 4.4.4.4 for ACAS equipped threats.

4.4.3.5 *Own aircraft trajectory.* Predicted altitude separation at closest approach is based on the following assumptions concerning the response of the ACAS II aircraft to the RA:

- a) for preventive RAs, the altitude rate of own aircraft will remain within the limits specified by the RA;
- b) for corrective RAs, the trajectory of own aircraft will consist of unaccelerated flight at the current rate for  $T_p + T_s$ , followed by a constant acceleration ( $\ddot{Z}_g$ ) in the vertical plane to achieve the selected altitude rate ( $\dot{Z}_g$ ) and thereafter unaccelerated motion at this rate.

*Note.— The predicted time to closest approach might be so short that the selected altitude rate,  $\dot{Z}_g$ , cannot be achieved.*

4.4.3.5.1 The parameter  $T_p$ , which represents pilot reaction time, takes the value 5 s for the initial RA strength or 2.5 s for any subsequent RA strength.

4.4.3.5.2 The value of the parameter  $T_s$  is chosen so that it models the system delay from receipt of the relevant SSR reply to the presentation of the RA to the pilot (Chapter 4, 4.3.5.10).

4.4.3.5.3 The parameter  $\ddot{Z}_g$  takes the value 0.35g for a reversed sense RA or an increased rate RA or 0.25g otherwise.

4.4.3.5.4 If the selected altitude rate,  $\dot{Z}_g$ , exceeds the performance capabilities of the aircraft, a value suitable for the aircraft is substituted.

#### 4.4.4 RESTRICTIONS ON RAS

4.4.4.1 *Range of available RA strengths.* The reference logic has a capability to provide the vertical RA strength options of Table A-2 in resolving encounters.

4.4.4.1.1 *Increased rate RAs.* The reference logic does not consider the increase climb and increase descend strength when selecting the initial strength of the RA. These RA strengths are only used when the predicted separation for the existing RA is inadequate and reversing the sense of the RA is not an acceptable option. These RA strengths are intended to convey an increased sense of urgency to the pilot. They correspond to increases in the selected altitude rate  $\dot{Z}_g$  beyond  $\dot{Z}_{clm}$  or  $\dot{Z}_{des}$ , as appropriate.

4.4.4.1.1.1 Increases in the selected altitude rate to 13 m/s (2 500 ft/min) are generated when all the following conditions are satisfied:

- a) a positive RA with the same sense is currently displayed and has been displayed for more than one cycle; and either
  - 1) if the threat is equipped or the current RA is not altitude crossing, confidence in the threat's tracked altitude rate is "high" (4.1.2.3.6.9), and the current RA strength is predicted to provide an altitude separation at closest approach of less than 61 m (200 ft); or

- 2) the threat is not equipped and the current RA is altitude crossing, and 10 s or less remain until closest approach and the threat's altitude at closest approach is currently predicted to be less than 61 m (200 ft) above or below the current altitude of own aircraft in the case of a descend or a climb RA respectively;
- b) the time remaining to closest approach is less than  $T_{ir}$  and greater than 4 s;
- c) own aircraft is either descending and above 1 450 ft AGL or climbing and above 1 650 ft AGL, and increase climb RAs are not inhibited by aircraft performance limits, and
- d) either  $\tau_u$  (4.3.4.4.1) is not increasing or, if it is, the range to the threat is less than 3.2 km (1.7 NM).

The following values are used for  $T_{ir}$ .

$S$	3	4	5	6	7
$T_{ir}, s$	13	18	20	24	26

*Note 1.— Condition 2) of a) above allows the use of an increased rate RA against a levelling-off, unequipped threat in an altitude-crossing encounter which does not qualify for a sense reversal (4.4.4.3.1). This situation can arise because the threat is levelling off with a low deceleration such that its predicted altitude at the point of closest approach follows the ACAS II aircraft's current altitude on each succeeding cycle. An increased rate RA could generate additional altitude separation.*

*Note 2.— Condition c) prevents undesirable interactions between the collision avoidance logic and the ground proximity warning system (GPWS).*

4.4.4.1.2 The default values for  $\dot{Z}_{clm}$  and  $\dot{Z}_{des}$  are 7.6 m/s (1 500 ft/min) and  $-7.6$  m/s ( $-1$  500 ft/min), respectively. If 7.6 m/s (1 500 ft/min) exceeds the aircraft's climb capability, a suitable value may be substituted to enable the generation of climb RAs. If the actual rate of climb or descent exceeds the default rate, the actual rate is substituted, if it is less than a maximum rate of 4 400 ft/min; otherwise the maximum rate of 4 400 ft/min is used.

*Note.— Climbs may be inhibited in response to discrete indications e.g. that the aircraft is at its ceiling. However, it is possible that certain aircraft will have such limited climb capability that RAs to climb at 7.6 m/s (1 500 ft/min) have to be permanently inhibited to comply with Chapter 4, 4.3.5.4.*

4.4.4.1.3 *RA retention.* Subject to the requirement that a descend RA is neither generated nor maintained below a specified altitude (Chapter 4, 4.3.5.4.1), the RA is not modified (Chapter 4, 4.3.5.6) if any of the following apply:

- a) the range test has given a negative result but the intruder remains a threat (4.3.5.1.1); or
- b) less than 2.5 s remain until closest approach; or
- c) the intruder is diverging in range but the RA has not yet been cancelled (4.3.5.1.1).

4.4.4.1.4 *Weakening RAs.* Subject to the requirement that a descend RA is not generated at low altitude (Chapter 4, 4.3.5.4.1), an RA is not weakened (Chapter 4, 4.3.5.7) if any of the following conditions apply:

- a) it is positive and current altitude separation is less than  $A_i$ ; or
- b) it (any strength) has been displayed for less than 10 s or, for a reversed sense RA, 5 s; or
- c) there is "low" confidence in the threat's tracked altitude rate; or
- d) the RA is a vertical speed limit RA.

Furthermore, positive RAs are not weakened beyond an RA strength allowing a return to level flight (“do not climb” for a downward RA; “do not descend” for an upward RA).

*Note.*— This limitation on weakening RAs does not apply to the declaration of an aircraft to be not a threat (Chapter 4, 4.3.5.1.1).

4.4.4.2 *Initial bias against altitude crossing.* A newly generated RA is non-crossing provided:

- a) a non-crossing RA is predicted to provide an altitude separation of at least  $A_i$  at closest approach; and
- b) responding to a non-crossing RA with a standard response (4.4.3.5) is predicted to preserve at least “minimum” vertical separation (4.4.2.1) throughout the entire time interval until closest approach.

4.4.4.3 *Sense reversal for an established threat.* Sense reversals are generated when the following conditions apply:

- a) the threat is not equipped or the threat is equipped, has a higher aircraft address, and at least 9 s have elapsed since it became a threat and own ACAS has not previously reversed its RA; and
- b) more than 4 s remain before closest approach; and
- c) the value of  $\tau_u$  (4.3.4.4.1) was not already rising by the time the range to the threat was 3.2 km (1.7 NM); and
- d) either:
  - 1)
    - i) the current RA is altitude crossing; and
    - ii) current altitude separation is at least 61 m (200 ft), or 30 m (100 ft) if more than 10 s remain before closest approach; and
    - iii) either
      - at the time the RA was generated the threat was predicted to cross the initial altitude of own aircraft, but currently the threat’s altitude at closest approach is predicted to be above or below the current altitude of own aircraft in the case of a climb or descend RA, respectively; or
      - at the time the RA was generated the threat was not predicted to cross the initial altitude of own aircraft, but current estimates of the separations predicted to be achievable for climb and descend RAs at closest approach show that greater separation will be obtained for a reversed sense RA; and
    - iv) by the time of reaching closest approach, own aircraft will, with reversed sense, be able to exceed the maximum bound on the threat’s altitude at closest approach (projected using the maximum altitude rate bound (4.1.2.3.4)); or
  - 2)
    - i) the current RA is not altitude crossing; and
    - ii) at least one of the following:
      - the threat has crossed own aircraft’s altitude by at least 30 m (100 ft) in the direction of the RA sense; or
      - the threat is not equipped and own aircraft has not yet crossed the altitude of the threat, but its vertical rate is opposite to the RA and an immediate manoeuvre to comply with the RA would not prevent an altitude crossing before closest approach; or

- the threat is not equipped and current separation does not exceed  $A_c$  (4.4.2.1.4), the vertical rates of own and the threat exceed 1 000 ft/min in the same direction, the RA has been positive for at least 9 s, confidence in the tracked rate of the threat is high, and either an altitude crossing is predicted to occur before closest approach or vertical separation at closest approach is predicted to be less than 30 m (100 ft).

*Note.*— *The sense of an RA for an established threat cannot be reversed except for coordination purposes or because the predicted separation at closest approach for the existing sense is inadequate (Chapter 4, 4.3.5.5).*

4.4.4.3.1 Climb RAs occurring as a result of reversals of downward-sense RAs are issued regardless of manoeuvre limitation indications.

4.4.4.4 *Strength selection for non-crossing RAs against ACAS-equipped threats.* In a conflict with an ACAS-equipped threat, in which the reference logic would normally generate a non-crossing climb or descend RA that is opposite in direction to own aircraft's existing vertical rate, an RA to limit the vertical rate to 0 ft/min will be generated instead, if the following conditions are met:

- a) own aircraft and the threat are converging vertically;
- b) own aircraft's vertical rate exceeds  $\dot{Z}_{lo}$ ;
- c) the threat aircraft's vertical rate is less than  $\dot{Z}_{lo}$ ; and
- d) the vertical separation that would be achieved at closest approach if both aircraft were to level off exceeds  $Z_{losep}$ .

4.4.4.4.1 The vertical speed limit 0 ft/min RA generated in accordance with 4.4.4.4 is retained if neither aircraft accelerates vertically toward the other with a change in rate in excess of  $\dot{Z}_t$ . Otherwise, the reference logic will immediately generate a climb or descend RA as appropriate for the RA sense.

4.4.4.4.2 The value 6 m/s (1 000 ft/min) is used for  $\dot{Z}_{lo}$ . The value 244 m (800 ft) is used for  $Z_{losep}$ .

## 5. ACAS II USE OF HYBRID SURVEILLANCE TECHNIQUES

### 5.1 Overview

5.1.1 Hybrid surveillance is the technique used by ACAS to take advantage of passive position information available via extended squitter. Using hybrid surveillance, ACAS validates the position provided by extended squitter through direct active range measurement. Initial validation is performed at track initiation. Revalidation is performed once per 10 seconds if the intruder becomes a near threat in altitude or range. Finally, regular once-per-second active surveillance is performed on intruders that become a near threat in both altitude and range. In this manner, passive surveillance (once validated) is used for non-threatening intruders thus lowering the ACAS interrogation rate. Active surveillance is used whenever an intruder becomes a near threat in order to preserve ACAS independence as an independent safety monitor. A block diagram of the hybrid surveillance algorithm is presented in Figure A-11.

5.1.2 The reported altitude in the extended squitter position report is loaded within the Mode S transponder from the same source used to provide the altitude reported in the reply to an ACAS addressed interrogation. The altitude reported in an extended squitter position report may therefore be used to update the altitude of a track undergoing active surveillance, in the event that the transponder fails to reply to active interrogations.

## 5.2 Hybrid surveillance equipment characteristics

### 5.2.1 INITIAL VALIDATION

5.2.1.1 A passive track is initiated by the receipt of an extended squitter with a 24-bit address that is not in the track file, nor is associated with a track undergoing active surveillance. This latter case can occur if the short squitter established an active track before an extended squitter containing position reports is received.

5.2.1.2 ACAS will handle an extended squitter acquisition the same way that it handles a short squitter acquisition. After receiving the required number of squitters at the ACAS MTL (the same number as specified for short squitters in Chapter 3, 3.1.2.8.5), an attempt is made at active surveillance for a prescribed number of times. A successful reply will lead to track acquisition. An unsuccessful attempt will lead to discarding acquisition for this aircraft address, since the ADS data could not be validated. Continued receipt of extended squitters will lead to a subsequent acquisition attempt.

5.2.1.3 In the case of an aircraft providing extended squitter information, a successful acquisition reply will provide the opportunity to validate the information. But in either case (short or long squitter), the same criteria for track acquisition are followed, in terms of the number of correlating squitters that are required and the number of interrogation attempts that are made.

5.2.1.4 Initial ADS information validation is performed at passive track initiation to determine if the track can be maintained on passive data. An active surveillance measurement is made using a short addressed interrogation which carries an ACAS cross-link command to provide the contents of register 05[HEX] (extended squitter airborne position) in the reply. The reply to this interrogation also provides the aircraft speed capability and the reported barometric altitude in addition to the ADS-B airborne position report. The relative range and bearing computed from own and intruder reported positions is compared to the active range and bearing measurements and the altitude provided in the position report is compared to the altitude obtained from the active interrogation. If the reported information does not agree with the range, bearing or altitude obtained via the active interrogation within limits recommended in Chapter 4, 4.5.1.3.2, the track is declared to be an active track and future extended squitters from this aircraft are ignored by ACAS.

### 5.2.2 REVALIDATION AND MONITORING

If the following condition is met for an aircraft with a relative altitude  $\leq 10\,000$  ft:

(Intruder altitude difference  $\leq 3\,000$  ft OR vertical *TAU* to  $3\,000$  ft  $\leq 60$  seconds) OR  
(Range difference  $\leq 3$  NM OR range *TAU* to  $3$  NM  $\leq 60$  seconds)

an active interrogation is made every 10 seconds to continuously revalidate and monitor the position reports. Any detected difference will result in the aircraft being declared an active track.

### 5.2.3 ACTIVE SURVEILLANCE

If the following condition is met for an aircraft with a relative altitude  $\leq 10\,000$  ft:

(Intruder altitude difference  $\leq 3\,000$  ft OR vertical *TAU* to  $3\,000$  ft  $\leq 60$  seconds) AND  
(Range difference  $\leq 3$  NM OR range *TAU* to  $3$  NM  $\leq 60$  seconds)

the aircraft is declared an active track and is updated on active range measurements once per second.

#### 5.2.4 THREAT EVALUATION DECLARATION

If the intruder aircraft is declared to be a threat or potential threat, active range measurement continues.

## 6. PERFORMANCE OF THE COLLISION AVOIDANCE LOGIC

### 6.1 Purpose of the performance requirements

6.1.1 The ACAS collision avoidance logic is the part of ACAS that receives information relating to identified intruders (i.e. any aircraft for which ACAS has established a track) and generates collision avoidance advisories on the basis of that information. In any ACAS equipment it is likely to take the form of software residing in a microprocessor and this software will implement a collection of mathematical algorithms. These algorithms might vary from one ACAS to another and the purpose of the performance requirements for the collision avoidance logic is to ensure that the performance of the mathematical algorithms is acceptable.

6.1.2 The development of the collision avoidance algorithms and their implementation as software are thought of as separate processes and these standards relate to the algorithms, even though, in practice, the software used to demonstrate that the algorithms are satisfactory might be closely related to that installed with ACAS. The performance requirements for the collision avoidance logic are not intended to guarantee that the collision avoidance software is satisfactory as software, though they are an essential ingredient of such a guarantee. Satisfactory performance of the software is to be achieved by using sound software engineering practices to ensure that the algorithms are implemented reliably.

6.1.3 The interoperability of the collision avoidance logics in any two equipments is achieved by ensuring that their RAs are consistent and that either RA alone is sufficient for the purpose of the system as a whole. Consistency is ensured by the requirements relating to coordination (Chapter 4, 4.3.5.5.1, 4.3.5.8 and 4.3.6.1.3). That either RA is sufficient is guaranteed by the collision avoidance logic performance requirements and, in particular, the requirement of satisfactory performance when the other aircraft is ACAS equipped but does not cooperate (Chapter 4, 4.4.2.1 j) 2)).

6.1.4 The performance requirements are intended to provide a global guarantee that the ACAS logic in question has an overall performance that is comparable with or superior to that of other ACAS logics. They do not describe the performance of the logic in any particular airspace. For many purposes, the best method of determining or studying the performance of an ACAS logic in a particular airspace is by means of simulations based on ATC ground radar data. This possibility is discussed further in 6.4.4.

### 6.2 Conditions under which the requirements apply

#### 6.2.1 COMMENT

The conditions given in Chapter 4, 4.4.2 are specified in order to define the subsequent requirements, but satisfactory performance is required in all normal operating conditions. This is to be demonstrated by varying the conditions in which the performance measures are calculated in a way that reflects the normal variations that might be expected and ensuring that the calculated performance measures are robust, i.e. that they do not degrade sharply as the conditions assumed deteriorate.

## 6.2.2 SURVEILLANCE ERRORS

6.2.2.1 Surveillance errors can take a number of forms:

- a) a track is not formed for the intruder;
- b) a track is formed late;
- c) a track is dropped prematurely;
- d) a track is formed but reports are not available each cycle; and
- e) the reports, e.g. of range, will be subject to measurement errors.

6.2.2.2 While any assessment of the effectiveness of ACAS as a whole must take failure to form tracks, item a), into account, there is no need to prove that the logic is effective when it has no data.

6.2.2.3 Late track formation, item b), could delay the generation of RAs (perhaps because the various trackers in the logic have not converged and the RA is delayed by low confidence) or result in an inappropriate initial RA (perhaps because the output of the trackers is used before it has converged). Best practice would be to determine the frequency of late track formation for the actual surveillance system to be used with the logic being tested.

6.2.2.4 Once a track is formed, missing reports can degrade the accuracy of the track or cause low confidence in the track, both of which could delay the initial RA, result in an inappropriate RA or delay changes in an RA after it has been generated. Best practice would be to determine the frequency of missing reports for the actual surveillance system to be used with the logic being tested. The probability that a report is missing on any given cycle will be a function of the range of the intruder, altitude and whether or not a report was missing on the previous cycle.

6.2.2.5 Actual bearing measurement errors are highly dependant on the airframe and the siting of the ACAS antenna and other antennas and obstacles fitted to the same airframe. The bearing measurements are characteristically so poor that early ACAS designs made no use of them in the collision avoidance logic. A later design, which includes a filter that inhibits RAs when the sequence of range measurements indicates a significant horizontal miss distance, used the bearing and bearing rate measurements to verify that neither aircraft is accelerating; the filter is disabled if the bearing measurements are not consistent with the diagnosed miss distance. The conditions specified in Chapter 4, 4.4.2 are intended to cover this sort of feature in the logic.

6.2.2.6 It is most unlikely that any ACAS installation will provide bearing measurements of sufficient accuracy to provide the primary basis of a miss distance filter or any other aspect of the collision avoidance logic.

6.2.2.7 Range and bearing measurements are also used to determine the relative position of the intruder for use in the traffic display. The requirements for this use are much less stringent than those of the collision avoidance logic, and the models specified in Chapter 4, 4.4.2.2 and 4.4.2.3 have no bearing on this use.

## 6.2.3 ALTITUDE QUANTIZATION

6.2.3.1 The intruder's altitude could be available as either Mode C or Mode S reports and is thus expressed in 100 ft or 25 ft quanta. Chapter 4, 4.4.2.1 c) specifies that 100 ft quanta be assumed for the purposes of confirming that the performance requirements are met. The performance of the collision avoidance logic is expected to be improved when the intruder's altitude is available as 25 ft quanta and it is desirable to confirm that this is the case.

6.2.3.2 In most cases, the altitude of own aircraft will be available to ACAS as a measurement prior to the formation of a Mode C or Mode S report and Chapter 4, 4.4.2.1 d) specifies that this is assumed. For installations where it is not possible to

provide the original altitude measurement to ACAS, the collision avoidance logic will have to use the Mode C or Mode S reports made by own aircraft. This is expected to degrade the performance of the logic but Chapter 4, 4.4.2.1.1 requires that this degradation be acceptable. The logic is not expected to meet the performance requirement when altitude reports (as opposed to measurements) are used for own aircraft. The test is whether the resulting measures are judged acceptable given that they result from an installation where it has been necessary to compromise performance by using input that does not match the normal standards, and whether they indicate that the logic is unduly sensitive to quantization of the altitude data for own aircraft.

#### 6.2.4 STANDARD ALTIMETRY ERROR MODEL

6.2.4.1 The standard altimetry error model is needed for the calculation of the effect of ACAS on the risk of collision (6.3.2). Although it is based on the observed performance of operational altimeters, there is no intention that the model be used as a reference recording that performance. Still less is there an implied requirement for altimeters to match the performance described in the model whether or not they are used in conjunction with ACAS. The model is standardized solely for the purpose of defining the conditions under which the requirements relating to the performance of the collision avoidance logic apply.

6.2.4.2 The model describes the distribution that is to be assumed for the errors in altimeter measurements. It excludes the effect of the quantization that is needed to create Mode C or Mode S altitude reports. Nevertheless, the calculation of the effect of ACAS on the risk of collision must take full account of this quantization and this is to be achieved by quantizing the simulated altitude measurements and thus forming simulated reports that are provided to the simulated ACAS logic.

6.2.4.3 The simulations of the effect of ACAS will include precise knowledge of the aircrafts' measured altitudes. Their actual altitudes are not known either to ATC or to the aircraft; they are the sum of the simulated measurement and the random altimeter error. In every encounter where the horizontal miss distance is very small, there is some risk of collision and it equals the probability that the difference in the actual altitudes of the two aircraft is small enough for them to collide. Thus the calculation of the effect of ACAS on the risk of collision (6.3.2) involves forming the statistical distribution of the error in the measured difference in the altitudes of the two aircraft: the convolution of two statistical distributions, one for each aircraft.

6.2.4.4 For the standard altimetry error model specified in Chapter 4, 4.4.2.4, the probability that the actual vertical separation  $d$  is less than a threshold value  $h$  (which is taken to be 100 ft in 6.3.2) is as follows:

for  $\lambda_1 = \lambda_2$  and  $a \geq h$

$$\text{Prob}(|d| \leq h) = \frac{1}{4\lambda} \exp\left(\frac{-(a+h)}{\lambda}\right) \left[ \exp\left(\frac{2h}{\lambda}\right) (2\lambda + a - h) - (2\lambda + a + h) \right]$$

for  $\lambda_1 = \lambda_2$  and  $a < h$

$$\text{Prob}(|d| \leq h) = 1 - \frac{1}{4\lambda} \exp\left(\frac{-(a+h)}{\lambda}\right) \left[ \exp\left(\frac{2h}{\lambda}\right) (2\lambda - a + h) + (2\lambda + a + h) \right]$$

for  $\lambda_1 \neq \lambda_2$  and  $a \geq h$

$$\text{Prob}(|d| \leq h) = \frac{\lambda_1^2 \exp\left(\frac{-a}{\lambda_1}\right) \sinh\left(\frac{h}{\lambda_1}\right) - \lambda_2^2 \exp\left(\frac{-a}{\lambda_2}\right) \sinh\left(\frac{h}{\lambda_2}\right)}{\lambda_1^2 - \lambda_2^2}$$



and for  $\lambda_1 \neq \lambda_2$  and  $a < h$

$$\text{Prob}(|d| \leq h) = \frac{\lambda_1^2 \left[ 1 - \exp\left(\frac{-h}{\lambda_1}\right) \cosh\left(\frac{a}{\lambda_1}\right) \right] - \lambda_2^2 \left[ 1 - \exp\left(\frac{-h}{\lambda_2}\right) \cosh\left(\frac{a}{\lambda_2}\right) \right]}{\lambda_1^2 - \lambda_2^2}$$

where  $\lambda_1$  and  $\lambda_2$  are the values of  $\lambda$  for the two aircraft, and  $a$  is the apparent vertical separation as in 6.3.2, i.e. the altitude separation as measured by the altimeters in the two aircraft.

### 6.2.5 STANDARD PILOT MODEL

6.2.5.1 The standard pilot model represents a reasonable expectation of pilots' normal reaction to RAs. However, it does not capture the full range of potential responses, for example, slow responses that undermine collision avoidance and excessively violent reactions that cause large deviations from clearance. For some responses, for example, failure to respond or a decision to move to the next flight level in response to a climb RA, it is not appropriate to examine the performance of the logic, but the following modifications to the standard model will provide an indication whether the logic is unduly dependent on an accurate pilot response.

6.2.5.2 In the context of Chapter 4, 4.4.3, the reduction in the risk of collision, a suggested deficient pilot response is:

- a) the pilot responds slowly, *viz.* in 8 s to an initial RA and in 5 s to a changed RA; and
- b) the pilot aims for an inadequate rate, *viz.* 200 ft/min less than the rate required.

6.2.5.3 In the context of Chapter 4, 4.4.4, the effect of ACAS on air traffic management (ATM), a suggested excessive response is:

- a) the pilot responds quickly, *viz.* in 3 s to an initial RA and in 1 s to a changed RA;
- b) the pilot aims for an excessive rate, *viz.* 500 ft/min more than the rate required; and
- c) the pilot fails to respond to weakening RAs.

6.2.5.4 The logic is not expected to meet the performance requirements when the pilot responds as described above, but calculation of the performance measures using these non-standard pilot responses will provide some insight into the sensitivity of the logic to the accuracy of the pilot's response. The test is whether the changes in the measures are judged acceptable given that they result from an inaccurate response, and whether they indicate that the logic is unduly sensitive to the response assumed from the pilot.

### 6.2.6 STANDARD ENCOUNTER MODEL

6.2.6.1 Effectively, there are two encounter models, one for use in risk ratio calculations (where the horizontal miss distance is small) and the other for use when assessing the compatibility of the logic design with ATM (where the horizontal miss distance can be comparable with the ATC horizontal separation minimum). This overcomes what would otherwise be an unacceptable simplification: both models treat the horizontal and vertical characteristics of the encounters independently.

6.2.6.2 The standard model is the result of an analysis of a large amount of ground radar data collected in two States. This means that one can expect the performance measures calculated using this standard model to be related to operational reality

even though that is not the purpose of the calculations. The data analysed revealed very considerable variation in the airspace characteristics expressed in the encounter model depending on the location of the radar providing the data. The characteristics of the data from the two States were radically different. This implies that a standard encounter model cannot provide predictions of performance that will be valid for any specific location. However, given that a standard model is essential to the definition of standard performance, the model standardized is considered sufficiently complex and representative.

6.2.6.3 To determine the parameters of the standard encounter model (Chapter 4, 4.4.2.6), for example the relative weights of the encounter classes, encounters were reconstructed from ground radar data. This required a reinterpretation of aspects of the encounters, examples of which are given below.

6.2.6.3.1 The definition of “Altitude layer” given for the standard encounter model (Chapter 4, 4.4.1) is simple because it is made solely for the purpose of standardizing the collision avoidance logic. When, in the real encounters observed in the ground radar data, ground level did not correspond to a pressure-altitude of 0 ft, it was necessary to distinguish between height above the ground and pressure-altitude with respect to mean sea level (MSL). The method used to determine the altitude layer appropriate for an encounter observed in real radar data was to place it in Layer 1 if it occurred less than 2 300 ft above ground level (AGL), and to use the pressure-altitude with respect to MSL otherwise. At locations of high altitude, one or more layers were sometimes missing.

6.2.6.3.2 The vertical rates of an aircraft at the beginning and the end of an encounter,  $\dot{z}_1$  and  $\dot{z}_2$  are, in the standard encounter model, values at precise times, viz.  $tca - 35$  s and  $tca + 5$  s. When processing the data for real encounters observed in the ground radar data, the values used for  $\dot{z}_1$  and  $\dot{z}_2$  were the average vertical rates over the first 10 s, i.e. [ $tca - 40$  s,  $tca - 30$  s], and the last 10 s, i.e. [ $tca$ ,  $tca + 10$  s], of the encounter.

6.2.6.3.3 In similar vein, in the real encounters  $tca$  was the actual time of closest approach, and  $hmd$  was the actual horizontal separation at closest approach. The vertical miss distance,  $vmd$ , was either the vertical separation at closest approach, for encounters in which  $hmd \geq 500$  ft, or it was the minimum vertical separation during the period of time in which the horizontal separation of the two aircraft was less than 500 ft.

6.2.6.3.4 Some aspects of the standard encounter model, e.g. the magnitude of speed changes during an encounter, could not be determined from examination of the ground radar data (because of the nature of the data) and had to be specified using a general understanding of aircraft dynamics.

6.2.6.3.5 To put the lack of precise correspondence between the model encounters and those observed in radar data into context, it is necessary to bear in mind that the purpose of the standard encounter model is to provide a basis for standardizing the performance of the collision avoidance logic. While, naturally, every realistic effort was made to ensure that the model is as faithful as possible to operational reality, precise fidelity is not required and will not have been achieved. This is not a reason for using an alternative model; the only model that is valid for assessing the performance of the collision avoidance logic against the requirements stated here is the model specified here for that purpose.

6.2.6.4 Any construction of the standard encounter model that can be proved equivalent to that specified in Chapter 4, 4.4.2.6 is acceptable. Two examples of such equivalent alternatives are given below.

6.2.6.4.1 Chapter 4, 4.4.2.6.1 specifies that the performance measures be calculated by creating sets of encounters defined by broad characteristics (specifically: the ordering of the aircraft addresses; the altitude layer; the encounter class; and the approximate value for the vertical miss distance) and combining the results from these sets by using the weights specified in Chapter 4, 4.4.2.6.2. This will involve as many simulations of relatively rare types of encounters, e.g. crossing encounters, as of the more common types of encounters, e.g. non-crossing encounters. This approach ensures that the full range of possibilities within each set is properly investigated. However, the same end can be achieved by creating a number of encounters for each set that is proportional to the specified weight and combining all the encounters into one much larger pool. The only caveat on this alternative approach is that the total number of encounters must be large enough to ensure that the results from the smallest set, considered in isolation, are statistically reliable.

6.2.6.4.2 The statistical distributions for each of the vertical rates have been specified by requiring that first an interval is selected within which the final value is to lie, and then the final value is selected using a distribution that is uniform within the interval. This is merely a device adopted for the sake of clear presentation of the tables in Chapter 4, 4.4.2.6.3.2.4. It would be equivalent to select the value directly using a statistical distribution that is linear within each of the intervals and for which the cumulative probability increases across each interval by an amount equal to the specified probability for that interval.

6.2.6.5 The encounters in the standard encounter model are constructed from a notional closest approach outwards. The time of this notional closest approach is fixed and written “*tca*” in Chapter 4, 4.4.2.6. In the vertical plane, the vertical rates 35 s before *tca* and 5 s after *tca* are selected and joined by a period of acceleration if necessary, and then the altitudes in the trajectory are fixed by requiring that the vertical separation at *tca* equals the selected value for “*vmd*”. In the horizontal plane, selected values for “*hmd*”, the approach angle, and the aircraft speeds define the relative trajectories of the two aircraft at the time *tca*. The aircraft turns and speed changes are then imposed by modifying the trajectories before and after *tca*. At the conclusion of this process, the time of closest approach only approximates *tca*.

### 6.2.7 ACAS EQUIPAGE OF THE INTRUDER

6.2.7.1 The standards specify three sets of conditions concerning the equipage of the intruder and the way the intruder aircraft is to be assumed to behave:

- a) the other aircraft involved in each encounter is not equipped;
- b) the other aircraft is ACAS equipped but follows a trajectory identical to that in the unequipped encounter; and
- c) the other aircraft is equipped with an ACAS having a collision avoidance logic identical to that of own ACAS.

6.2.7.2 The first circumstance a) ensures that the logic performs satisfactorily in encounters with an unequipped intruder. The other two circumstances both test the collision avoidance logic when the other aircraft is equipped but do so from different perspectives. Circumstance b) ensures that the logic performs satisfactorily under the constraints of the coordination process, while circumstance c) ensures that the benefits to be expected when both aircraft are equipped are realized.

6.2.7.3 The conditions applying in circumstance b) are intended to allow own ACAS to select its initial RA but to then apply the most pessimistic reasonable assumptions about the effect of the need for coordination on the performance of the own ACAS logic. When own aircraft has the lower aircraft address, the conditions of the test imply that the sense of the RA cannot be reversed. Furthermore, the intruder does not generate an RA and an RAC until the own ACAS RA is announced because an early design included an initial coordination delay (the purpose of which was to allow the coordination to complete and avoid the pilot seeing rapid changes in the RA); the intention of the requirement is to ensure that performance is satisfactory in spite of the deleterious effects of any such delay.

6.2.7.4 Circumstance c) requires that the behaviour of the two aircraft be fully cooperative, but the fact that both ACAS are using the subject logic ensures that the performance measure relates to the subject logic and that the subject logic is effective.

6.2.7.5 As discussed above, the performance specifications are intended to ensure satisfactory operation of the logic and not the system as a whole. To the extent that they are capable of wider interpretation in terms of the benefits of the system as a whole in an operational environment, circumstance c) might be thought to provide the more credible performance measure for ACAS-ACAS encounters. The specified performance of the logic in circumstance b) is worse than that where the intruder is not equipped, because circumstance b) invokes only the constraints imposed by coordination. However, the fact that the cooperation of an intruder cannot be guaranteed and that some pilots will fail to respond to RAs on occasion means that all three measures have operational relevance.

### 6.3 Reduction in the risk of collision

#### 6.3.1 STATUS OF THE LOGIC RISK RATIO

6.3.1.1 The risk ratio calculated for the purposes of Chapter 4, 4.4.3 is a measure of the performance of the logic and not the ACAS as a whole. For example, ACAS can prevent a collision by prompting the pilot to carry out a successful visual search for the intruder and it can fail because a track is not established or the pilot ignores the RA; these are aspects of the total system that are not reflected in the calculations required for Chapter 4, 4.4.3.

6.3.1.2 When considering the relevance of the “logic risk ratio” figures calculated for Chapter 4, 4.4.3 to operations or policy decisions, it might be helpful to regard them as solely the reliability that can be attached to RAs. They express the effect that following an RA will have on the immediate risk of collision when, at the time it is issued, the pilot has no information other than the RA on which to base a decision whether to follow the RA or ignore it. As a rough guide, the collision risk created by ACAS arises from following the RA so the logic risk ratio overstates this “induced risk ratio”; on the other hand, it also overstates the capability of ACAS to prevent collisions because of the many other failure modes in the total system.

6.3.1.3 The figures calculated for the purposes of Chapter 4, 4.4.3 are unsuitable as guidance concerning the effect of ACAS on the overall risk of collision in an airspace or faced by an airline.

#### 6.3.2 CALCULATION OF THE LOGIC RISK RATIO

6.3.2.1 The risk ratio  $R$  can be written:

$$R = \frac{\sum \text{probability of a collision with ACAS}}{\sum \text{probability of a collision without ACAS}}$$

where the summation is over all encounters, or, more practically, all encounters that contribute to the total risk of collision with or without ACAS. The need for the characteristics and statistics of the encounters to be representative of operational realities is standardized in Chapter 4, 4.4.2.6 and discussed in 6.2.6.

6.3.2.2 The estimated risk of collision depends on the interpretation of the word “collision”. While this problem is largely avoided by expressing the requirement in terms of the ratio between the risks of collision with and without ACAS, it is important that realistic allowance is made for the size of the largest aircraft. It would be reasonable to treat a vertical separation of less than 100 ft between the centre points of the two aircraft as if it were small enough to allow a collision. It would not be advisable to use significantly larger miss distances as approximations to collisions because it has been found that the calculated risk ratio is sensitive to the definition of “collision” even though it is a ratio.

6.3.2.3 If the approximation is made that a collision occurs when

$|d| < 100$  ft, where  $d$  is the actual vertical separation

Then

$$R = \frac{\sum \text{prob}(|d| < 100 \text{ ft with ACAS})}{\sum \text{prob}(|d| < 100 \text{ ft without ACAS})}$$

where now the summation is over all encounters with zero or extremely small horizontal miss distance.

6.3.2.4 Now introduce  $e$ , the altimeter error and  $a$ , the apparent vertical separation and note that

$$a = d + e$$

$a$  is conceptually the altitude separation as measured by altimeters. It should not be necessary to consider quantization errors because the modelled altimeter readings can be known with arbitrary precision in the computer simulations. They are quantized before they are provided to ACAS as modelled Mode C reports, which ACAS tracks. This is why the standard Chapter 4, 4.4.2 excludes quantization effects.

6.3.2.5 Define  $a_{with}$  to be the apparent vertical separation with ACAS and  $a_{without}$  to be the apparent vertical separation without ACAS. Then

$|d| < 100 \text{ ft}$  with ACAS

if and only if  $|a_{with} - e| < 100 \text{ ft}$

i.e.  $a_{with} - 100 \text{ ft} < e < a_{with} + 100 \text{ ft}$

and similarly

$|d| < 100 \text{ ft}$  without ACAS

if and only if  $|a_{without} - 100 \text{ ft} < e < a_{without} + 100 \text{ ft}$

6.3.2.6 Risk ratio is thus given by

$$R = \frac{\sum \text{prob}(a_{with} - 100 \text{ ft} < e < a_{with} + 100 \text{ ft})}{\sum \text{prob}(a_{without} - 100 \text{ ft} < e < a_{without} + 100 \text{ ft})}$$

In order to use this formula to calculate risk ratio, the values of  $a_{with}$  and  $a_{without}$  must be determined for a collection of encounters that is fully representative of all the potential actual encounters in which there is both a risk of collision without ACAS and a risk that ACAS will induce a collision. When these values of hypothetically measured altitude separation are known, knowledge of the errors in altitude measurement completes the calculation.

### 6.3.3 INDUCED AND UNRESOLVED RISK

6.3.3.1 It is not sufficient to demonstrate that ACAS will prevent collisions that might occur in its absence. The risk that ACAS logic could cause collisions in otherwise safe circumstances must be fully considered, not least because in managed airspace the number of encounters potentially facing an induced risk greatly exceeds the number of near collisions.

6.3.3.2 The upper limit on the logic risk ratio standardized at Chapter 4, 4.4.3 effectively places an approximate upper limit on the ACAS induced risk of collision. Although some other failures could cause ACAS to induce a collision, e.g. pilots manoeuvring on a TA or an RA directing the aircraft into the trajectory of an unseen third party, the induced risk is largely attributable to following RAs. In operational conditions, failure to raise or follow an RA will reduce the risk of an induced collision (even though it increases the absolute risk).

6.3.3.3 The requirement is that the logic is designed to reduce the risk of collision and no distinction is drawn between risk induced by the logic and risk that it is unable to resolve. It is possible to draw such a distinction and even to subdivide the risk into that due to altimeter error and that due to inappropriate operation of the logic but it is considered that this exercise has little value for the design of the logic.

### 6.3.4 USE OF GROUND RADAR DATA TO CALCULATE RISK RATIO

It is possible to use encounters observed in ground radar data as the basis of the safety calculations described in 6.3.2. However,

it is difficult to interpret the results because the calculation concerns extremely rare events and, even when many months of data are used, trajectories have to be modified to insert a risk of collision that was absent in the actual encounters. It is more practicable to use the radar data to inform the choice of the weights to be ascribed to the various encounter classes in the encounter model and thus produce a version of the idealized encounter model that is more representative of the airspace in question than the standard model presented here.

## 6.4 Compatibility with ATM

### 6.4.1 NUISANCE ALERT RATE

6.4.1.1 ACAS is required to diagnose a risk of imminent collision on the basis of incomplete information. Furthermore, this information has to be independent of that providing the primary basis for aircraft separation. It follows that there will be alerts in encounters where, from an operational perspective, there would seem to be no risk of collision. Standard Chapter 4, 4.4.4.1 requires that these nuisance alerts be as infrequent as possible.

6.4.1.2 The specification of a nuisance RA given in Chapter 4, 4.4.4.1.2 is made with the view that an RA is a nuisance if normal standard separation is not clearly lost. Additionally, it is intended that the horizontal separation threshold is sufficiently stringent to require the use of a horizontal miss distance filter. The horizontal separation threshold has been set at 40 per cent of normal separation, and the vertical separation threshold has been set at a figure based on an ATC tolerance of deviations of 200 ft from altitude clearance.

### 6.4.2 COMPATIBLE SENSE SELECTION

The requirement at Chapter 4, 4.4.4.2 is not intended to constrain the manner in which dangerous encounters are resolved, but rather is based on an appreciation that the majority of RAs are likely to be generated in encounters where there is no danger of collision. It places a statistical limit on the frequency with which ACAS disrupts ATC or the normal operation of the aircraft by inverting the vertical separation of two aircraft.

### 6.4.3 DEVIATIONS CAUSED BY ACAS

The restrictions on the deviations that may be caused by following RAs, Chapter 4, 4.4.4.3, limit the disruption to normal aircraft operation as well as to ATC. While deviations from altitude clearances are the most obviously disruptive to ATC, other deviations, such as that caused by an RA to climb when the aircraft is descending, could be viewed equally seriously by ATC.

### 6.4.4 USE OF GROUND RADAR DATA OR THE STANDARD ENCOUNTER MODEL

6.4.4.1 Conformance with the requirement for compatibility with ATM can be tested most convincingly using simulations based on reconstructions of actual operational encounters occurring within the coverage of ATC ground radars, provided that only a small proportion of the aircraft thus observed are equipped with ACAS. However, the results of such simulations based on actual data will reflect the particular properties of the airspace (or airspaces) in which the data were collected as much as those of the collision avoidance logic used. Thus, there are considerable practical difficulties in using real encounter data to validate collision avoidance logic, and the provisions of Chapter 4, 4.4.4 assume the use of artificial encounters based on the standard encounter model specified in Chapter 4, 4.4.2.6.

6.4.4.2 The use of the standard encounter model to obtain performance measures describing the operation of the collision avoidance logic will provide only indirect evidence concerning its operation in any particular airspace. Authorities that have access to ground radar data and wish to understand the interaction of ACAS with local ATC practices are advised to use

simulations based on their ground radar data rather than the standard encounter model. In doing so, they need to note that the results can be subverted if the aircraft observed are already equipped with ACAS. They will also need to collect sufficient data to ensure that the simulated RAs derived from the data are statistically representative; for example, data collected over 100 days in one State contained very few examples of some types of RAs.

### **6.5 Relative value of conflicting objectives**

The design of the collision avoidance logic for ACAS must strike an operationally acceptable balance between the reduction in the risk of collision and the disruption caused by ACAS alerts. The requirements relating to the risk of collision (Chapter 4, 4.4.3) and the disruption to ATC (Chapter 4, 4.4.4) are minimum standards that are known to be achievable from work with a prototype system. Other designs are only acceptable when it can be demonstrated that the risk of collision and the disruption to ATC have both been minimized as much as practicable in the context of a need to minimize the other.

## TABLES

Table A-1

<i>Nominal altitude band</i>	<i>SLC command code</i>	<i>Altitude threshold at which sensitivity level value changes</i>	<i>Hysteresis values</i>
0 to 1 000 ft AGL	2	1 000 ft AGL	±100 ft
1 000 ft to 2 350 ft AGL	3	2 350 ft AGL	±200 ft
2 350 ft AGL to FL 50	4	FL 50	±500 ft
FL 50 to FL 100	5	FL 100	±500 ft
FL 100 to FL 200	6	FL 200	±500 ft
above FL 200	7		

Table A-2. RA strength options

<i>Constraint</i>	<i>Type</i>	<i><math>\dot{Z}_g</math></i>
Upward sense RA		
Increased climb	Positive	$>\dot{Z}_{clm}$
Climb	Positive	$\dot{Z}_{clm}$
Do not descend	VSL	0
Do not descend faster than 2.5 m/s	VSL	-2.5 m/s (-500 ft/min)
Do not descend faster than 5.1 m/s	VSL	-5.1 m/s (-1 000 ft/min)
Do not descend faster than 10 m/s	VSL	-10 m/s (-2 000 ft/min)
Downward sense RA		
Increased climb	Positive	$<\dot{Z}_{des}$
Descend	Positive	$\dot{Z}_{des}$
Do not climb	VSL	0
Do not climb faster than 2.5 m/s	VSL	+2.5 m/s (+500 ft/min)
Do not climb faster than 5.1 m/s	VSL	+5.1 m/s (+1 000 ft/min)
Do not climb faster than 10 m/s	VSL	+10 m/s (+2 000 ft/min)



FIGURES

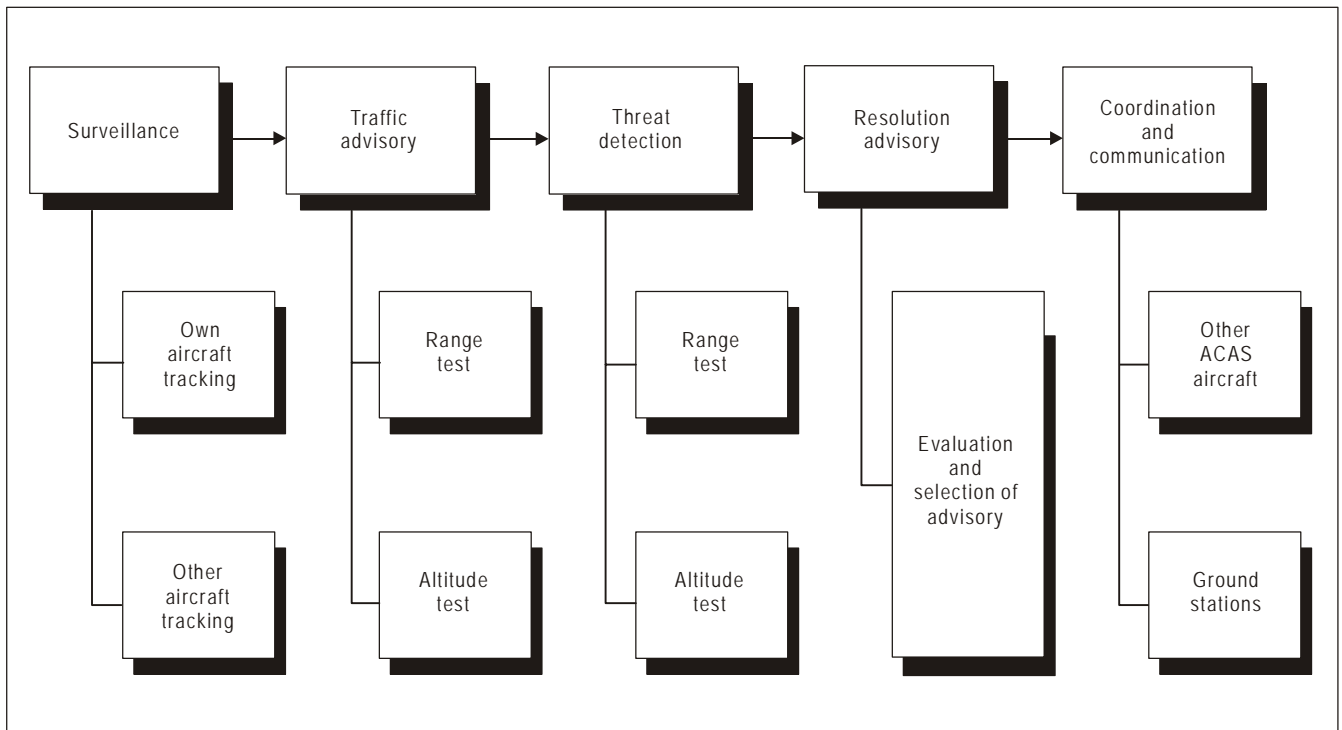

Figure A-1. Illustration of ACAS functions

STEP NUMBER		MINIMUM EFFECTIVE RADIATED INTERROGATION POWER (dBm)	INTERFERENCE LIMITING PRIORITY	MTL (-dBm)	
1		S . . I	52	1	74
2	TOP	S . I	51	5	74
3	ANTENNA	S . . I	50	9	74
4		S . I	49	13	74
5	FORWARD	S . . I	48	17	74
6	DIRECTION	S . I	47	21	74
7		S . . I	46	25	74
8		S . I	45	29	73
9		S . . I	44	33	72
10		S . I	43	37	71
11		S . . I	42	41	70
12		S . I	41	45	69
13		S . . I	40	49	68
14		S . I	39	53	67
15		S . . I	38	57	66
16		S . I	37	61	65
17		S . . I	36	64	64
18		S . I	35	67	63
19		S . . I	34	70	62
20		S . I	33	73	61
21		S . . I	32	76	60
22		S . I	31	77	59
23		S . . I	30	78	58
24		. . . I	29	79	57

EFFECTIVE RADIATED POWER (dBm)

NOTES.— “I” indicates ERP of  $P_1$ ,  $P_3$ , and  $P_4$  interrogation pulses.  
 “S” indicates ERP of  $S_1$  suppression pulse.  
 “S . I” means that the  $S_1$  ERP is 2 dB less than the interrogation ERP.  
 “S . . I” means that the  $S_1$  ERP is 3 dB less than the interrogation ERP.  
 In steps 24, 63, 64, 79 and 83, no  $S_1$  pulses are transmitted.

Figure A-2a. Example of high-density whisper-shout sequence

STEP NUMBER		MINIMUM EFFECTIVE RADIATED INTERROGATION POWER (dBm)	INTERFERENCE LIMITING PRIORITY	MTL (-dBm)	
25, 26		S..I	48	2, 3	74
27, 28	TOP	S.I	47	6, 7	74
29, 30	ANTENNA	S..I	46	10, 11	74
31, 32		S.I	45	14, 15	73
33, 34		S..I	44	18, 19	72
35, 36	LEFT & RIGHT	S.I	43	22, 23	71
37, 38	DIRECTIONS	S..I	42	26, 27	70
39, 40		S.I	41	30, 31	69
41, 42		S..I	40	34, 35	68
43, 44		S.I	39	38, 39	67
45, 46		S..I	38	42, 43	66
47, 48		S.I	37	46, 47	65
49, 50		S..I	36	50, 51	64
51, 52		S.I	35	54, 55	63
53, 54		S..I	34	58, 59	62
55, 56		S.I	33	62, 63	61
57, 58		S..I	32	65, 66	60
59, 60		S.I	31	68, 69	59
61, 62		S..I	30	71, 72	58
63, 64		...I	29	74, 75	57
65		S.I	43	4	71
66		S..I	42	8	70
67		S.I	41	12	69
68		S..I	40	16	68
69		S.I	39	20	67
70		S..I	38	24	66
71		S.I	37	28	65
72		S..I	36	32	64
73		S.I	35	36	63
74		S..I	34	40	62
75		S.I	33	44	61
76		S..I	32	48	60
77		S.I	31	52	59
78		S..I	30	56	58
79		...I	29	60	57
80		S..I	34	80	62
81		S..I	32	81	60
82		S..I	30	82	58
83		.I	28	83	56

EFFECTIVE RADIATED POWER (dBm)

NOTES.— “I” indicates ERP of P<sub>1</sub>, P<sub>3</sub>, and P<sub>4</sub> interrogation pulses.

“S” indicates ERP of S<sub>1</sub> suppression pulse.

“S·I” means that the S<sub>1</sub> ERP is 2 dB less than the interrogation ERP.

“S..I” means that the S<sub>1</sub> ERP is 3 dB less than the interrogation ERP.

In steps 24, 63, 64, 79 and 83, no S<sub>1</sub> pulses are transmitted.

Figure A-2a. Example of high-density whisper-shout sequence (cont)

STEP NUMBER	MINIMUM EFFECTIVE RADIATED INTERROGATION POWER (dBm)	INTERFERENCE LIMITING PRIORITY	MTL (-dBm)
1	52	<i>Note.— Each 1 dB reduction in the sequence follows the priority for the forward beam in Figure A-2a.</i>	74
2	48		74
3	44		72
4	40		68
5	36		64
6	32		60
7, 8	48	<i>Note.— Each 1 db reduction in the sequence follows the priority for the right/left beam in Figure A-2a.</i>	74
9, 10	44		72
11, 12	40		68
13, 14	36		64
15, 16	32		60
17	43		<i>Note.— Each 1 db reduction in the sequence follows the priority for the rear beam in Figure A-2a.</i>
18	39	67	
19	35	63	
20	31	59	
21	34	<i>Note.— Each 1 db reduction in the sequence follows the priority for the bottom beam in Figure A-2a.</i>	62
22	32		60
23	30		58
24	28		56

NOTES.— “I” indicates ERP of  $P_1$ ,  $P_3$ , and  $P_4$  interrogation pulses.

“S” indicates ERP of  $S_1$  suppression pulse.

“S . . I” means that the  $S_1$  ERP is 3 dB less than the interrogation ERP.

“S . . . . . I” means that the  $S_1$  ERP is 10 dB less than the interrogation ERP.

In the last steps of each quadrant, no  $S_1$  pulses are transmitted.

**Figure A-2b. Example of low-density whisper-shout sequence**

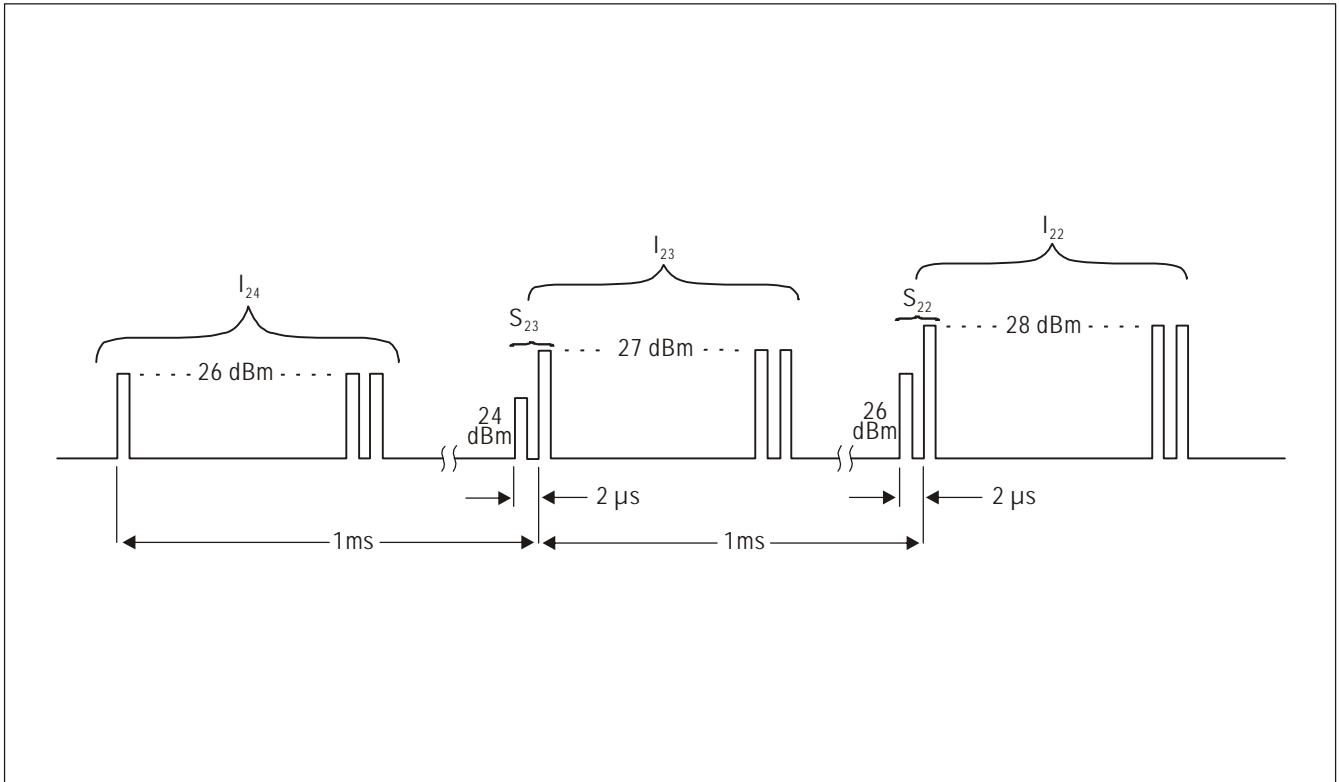

Figure A-3. Timing for lowest power steps in omnidirectional whisper-shout sequence for top antenna

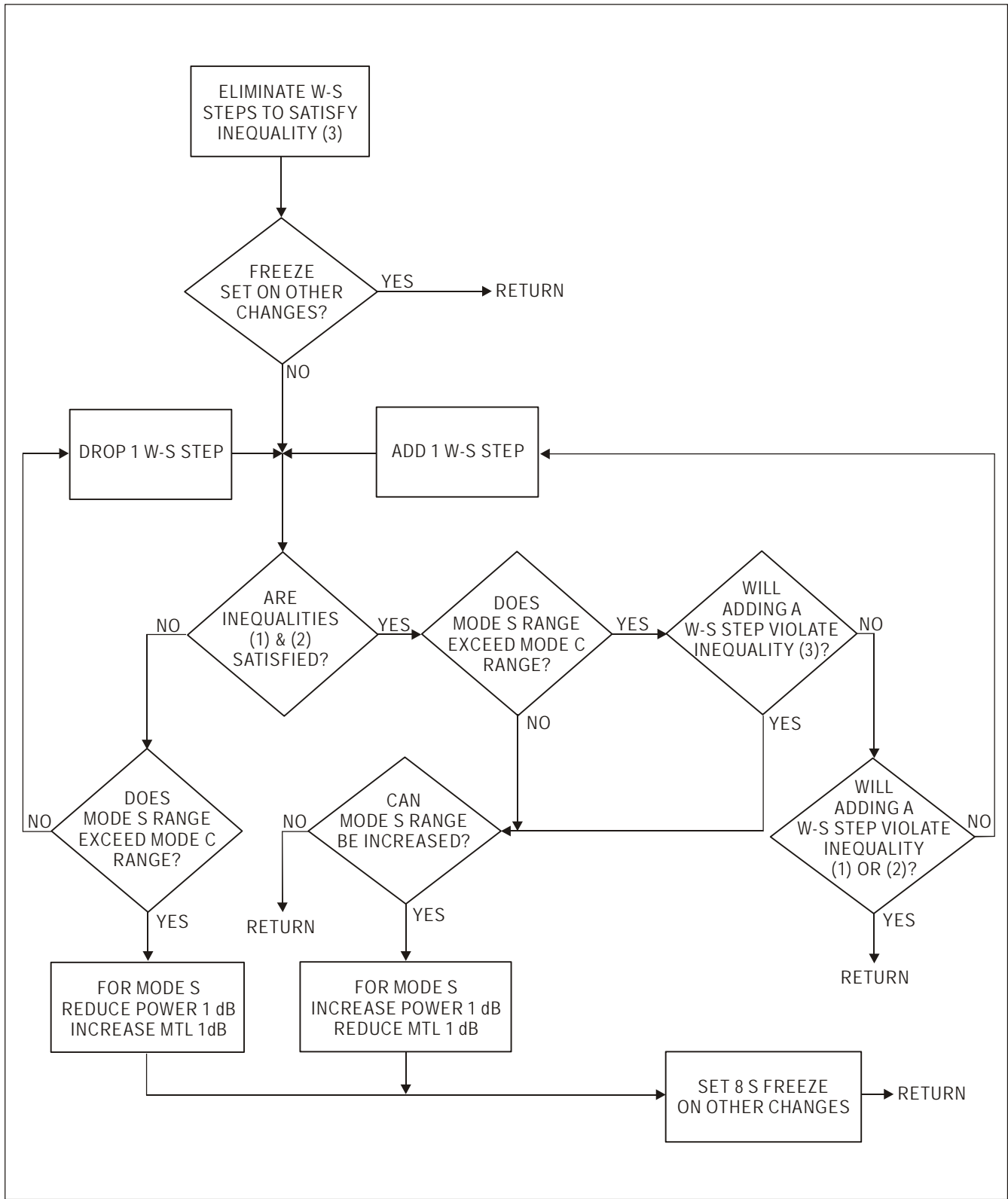

Figure A-4. Interference limiting flow diagram

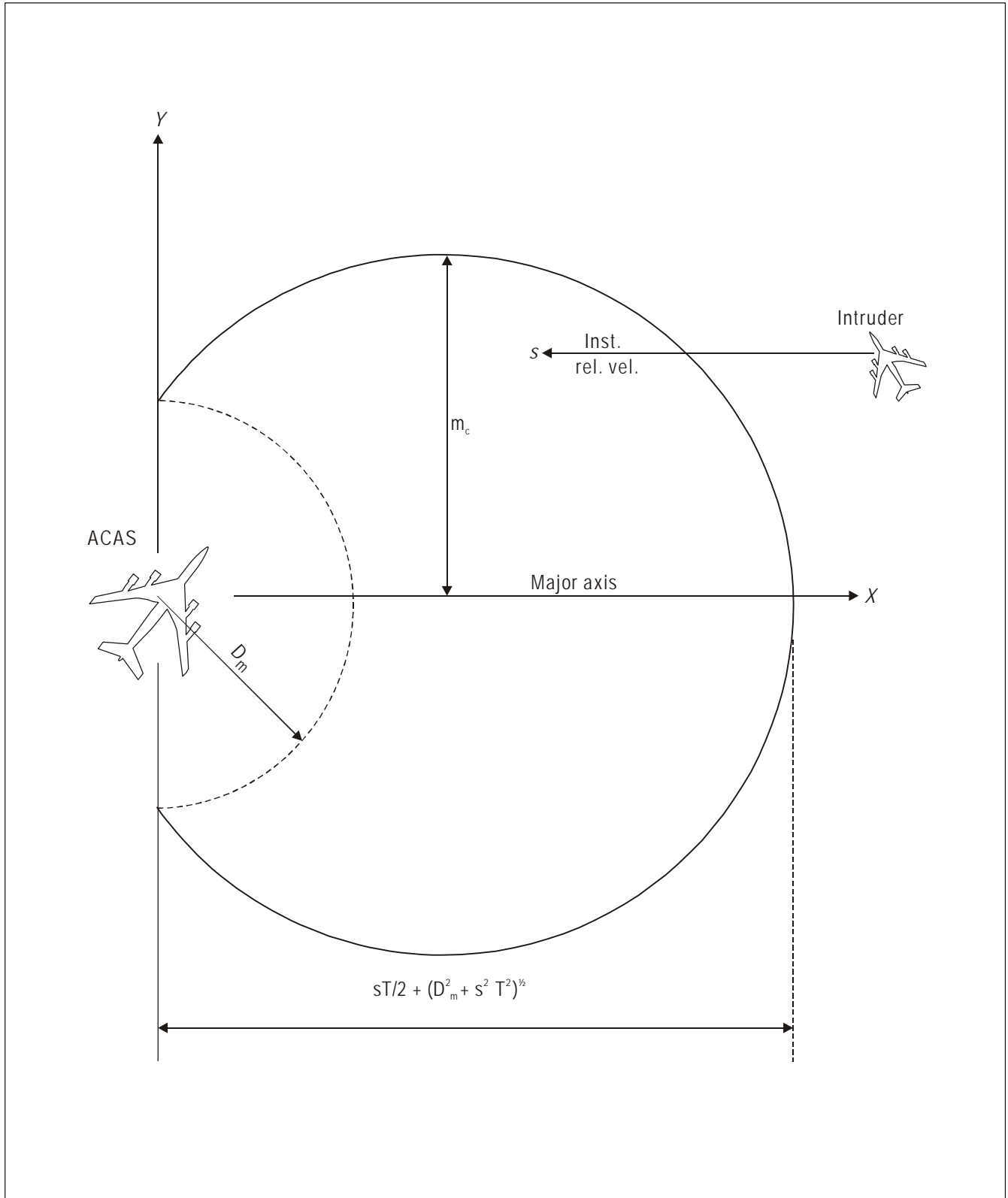

Figure A-5. Section through protected volume in the instantaneous collision plane

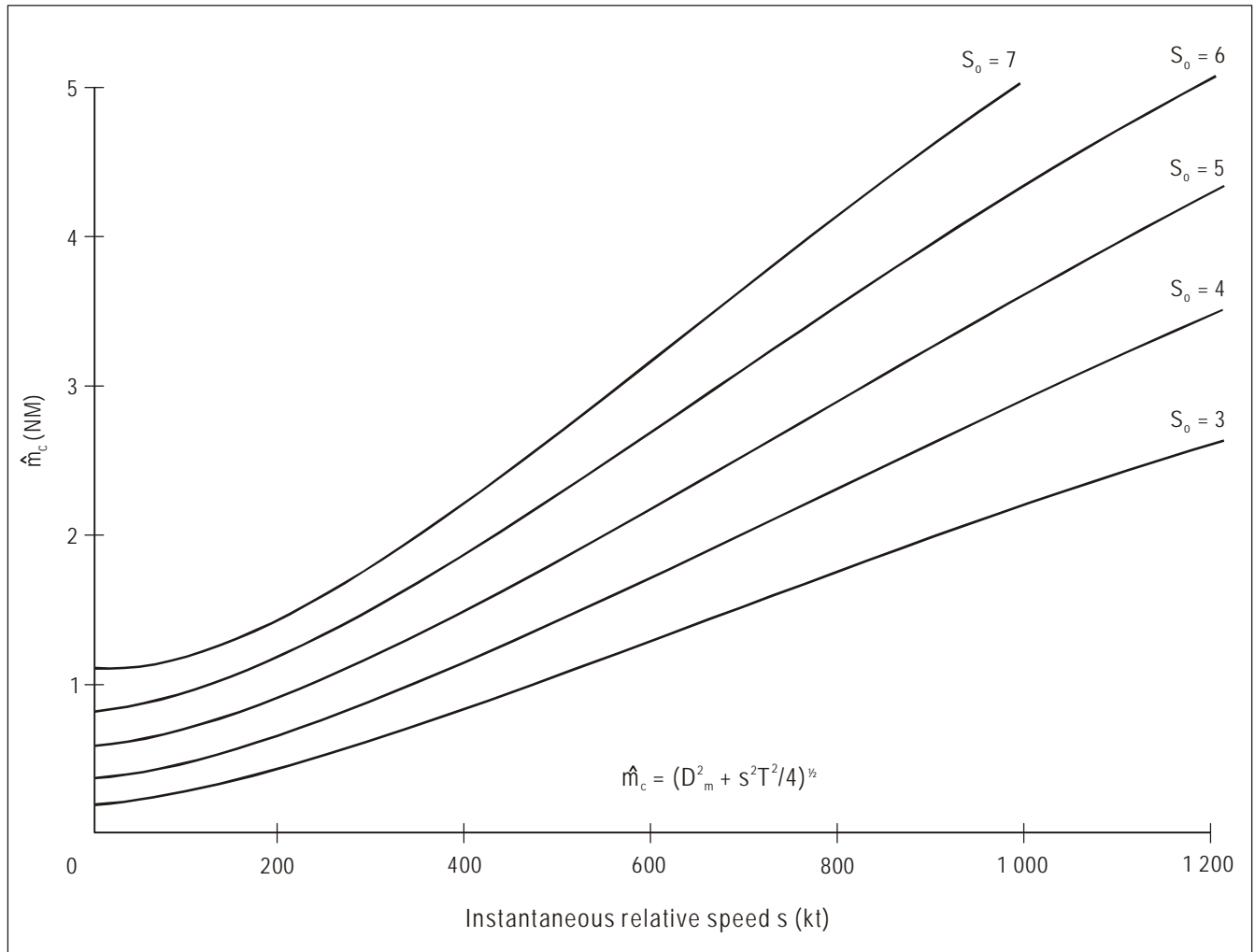

Figure A-6. Critical miss distance



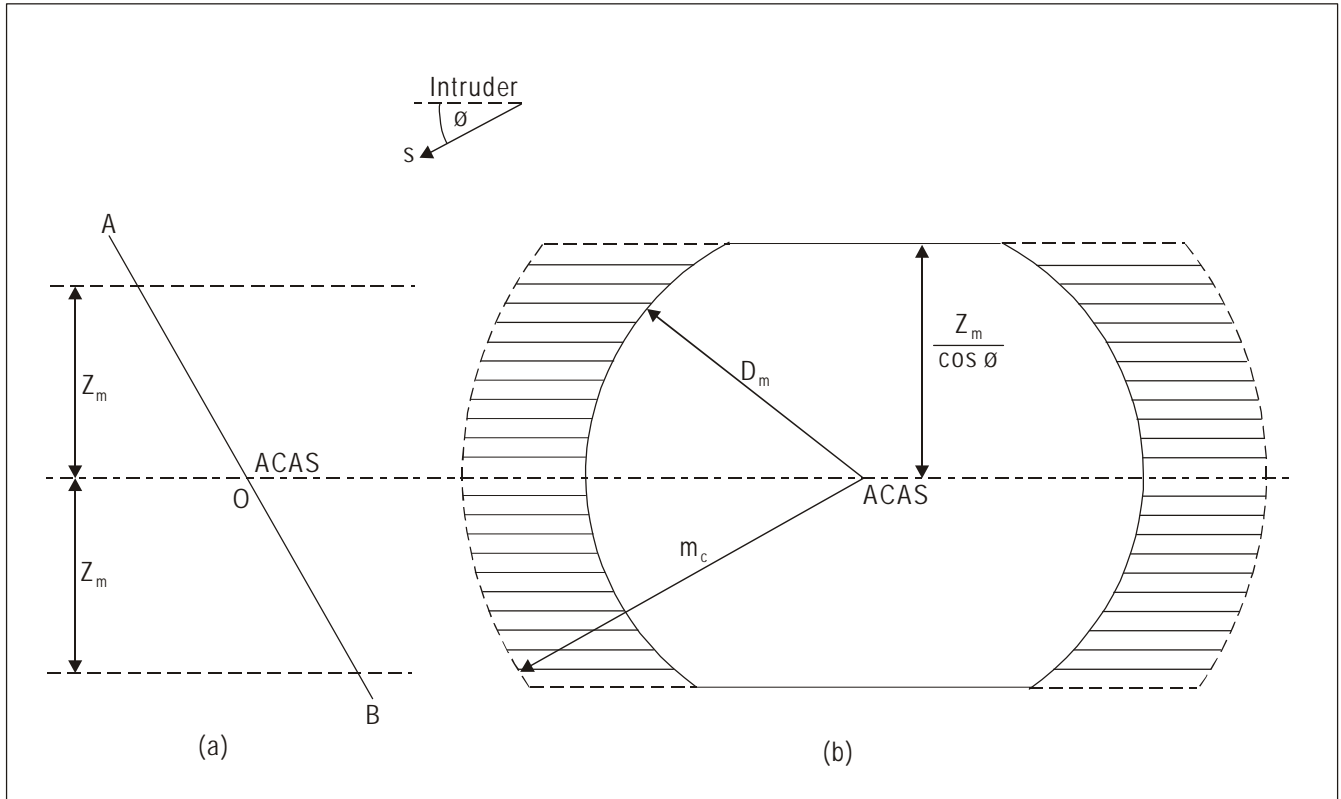

Figure A-7. Critical area for ideal altitude test

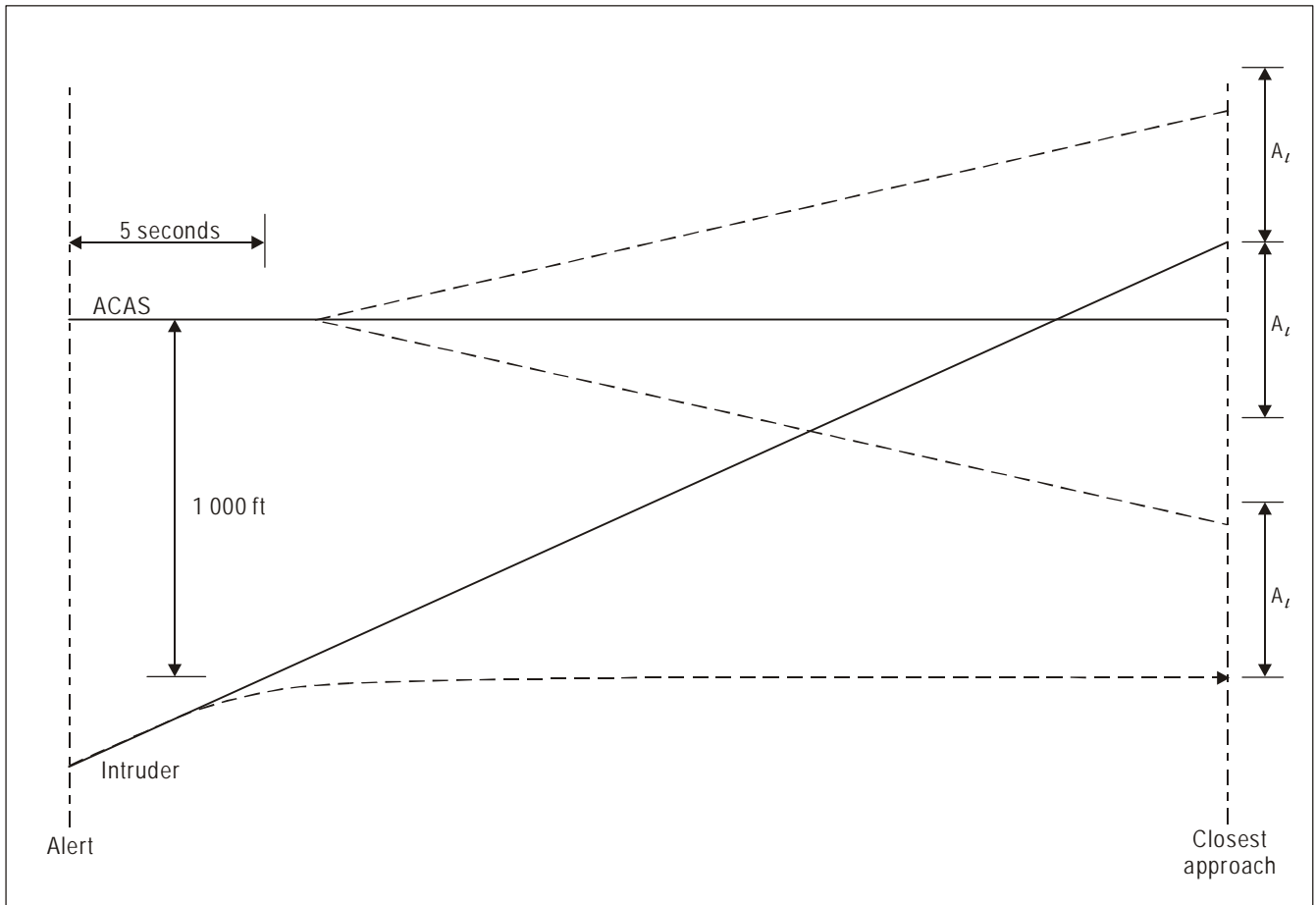

Figure A-8. Induced close encounter

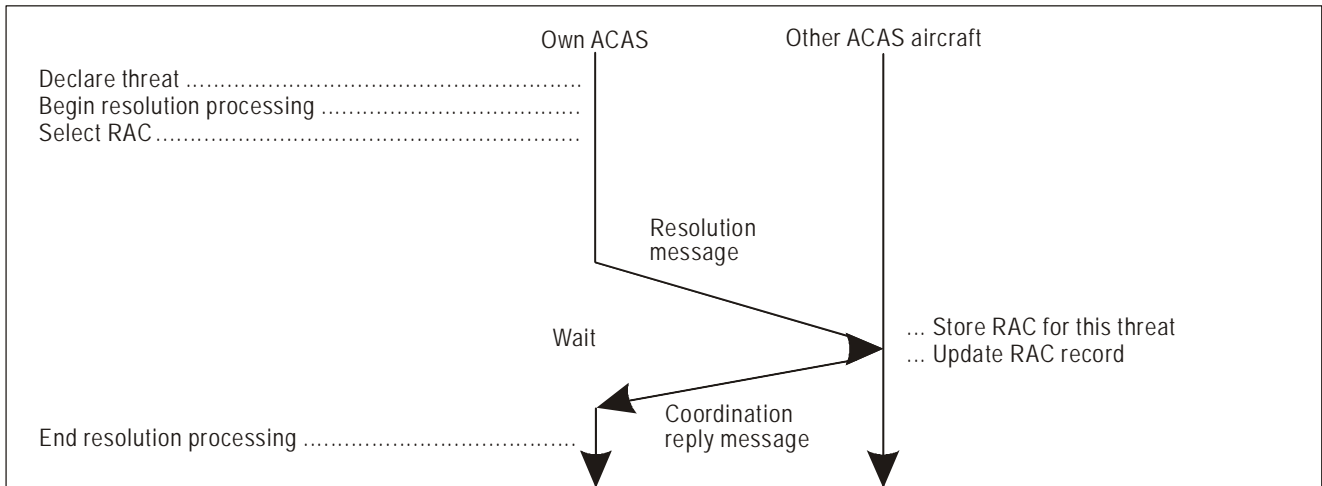

Figure A-9. Coordination sequence

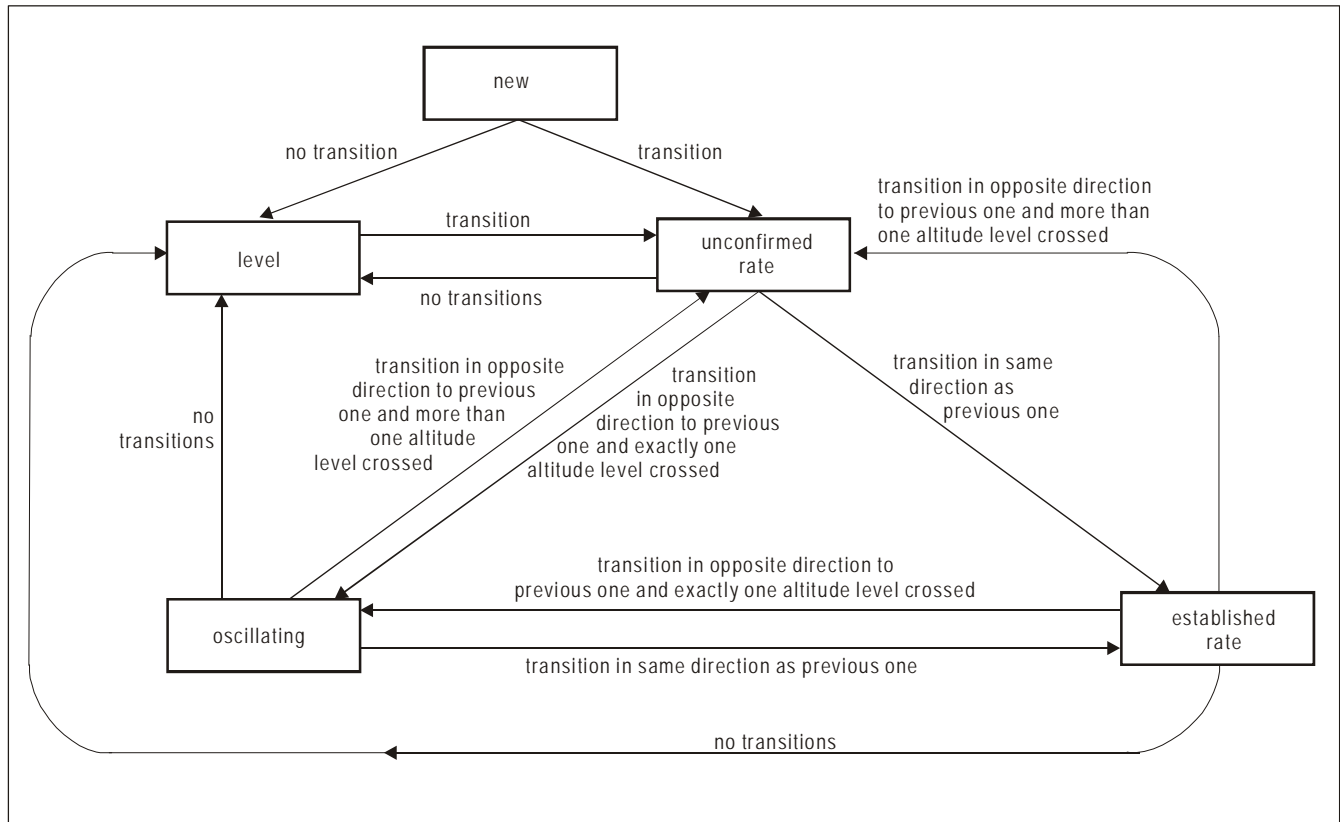

Figure A-10. Changes between track classifications

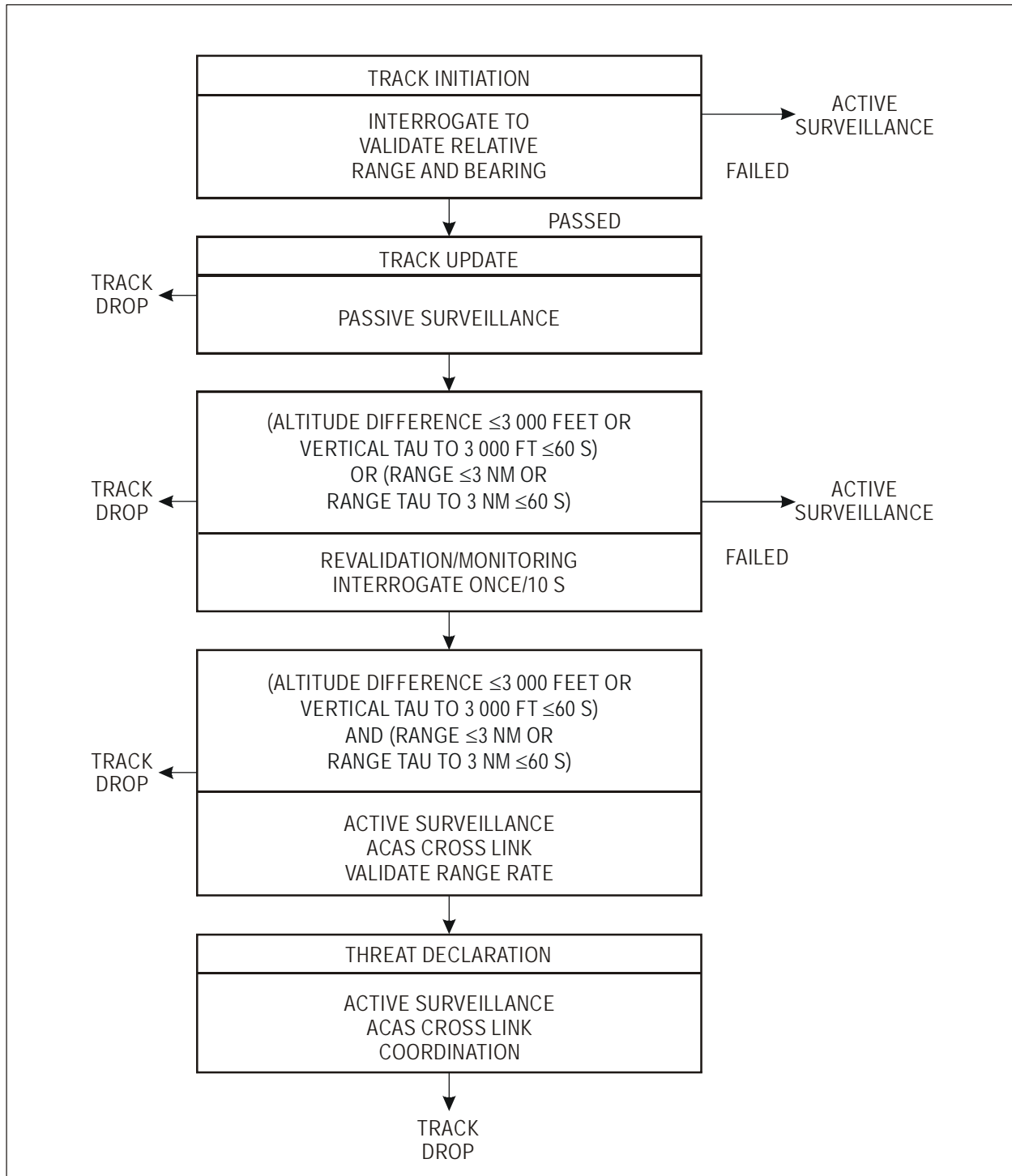

Figure A-11. ACAS hybrid surveillance algorithm

— END —





